

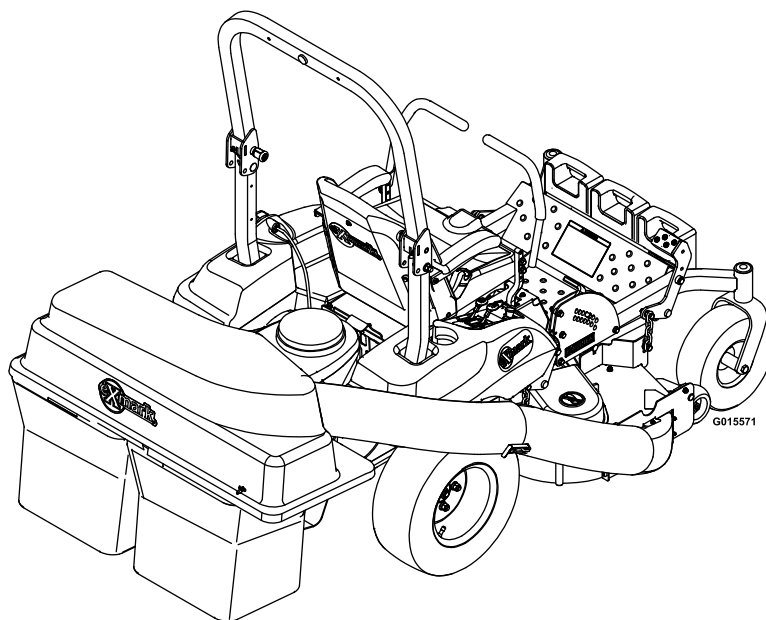

PIONEER® BAGGER

Model No. 116-5000—Serial No. 31500000 and Up

Picture below may not reflect actual product.



Parts Manual

Ordering Replacement Parts

To order replacement parts, please supply the part number, the quantity, and the description of each part desired.

Understanding Reference Numbers

Each identified part in an illustration has a reference number. The reference number for a part also appears in the parts list, along with other information about the part.

This catalog uses two special reference number formats, one to indicate parts in a service assembly and another to indicate the quantity of a given part in an illustration.

Service Assembly Reference Numbers

Parts in service assemblies have reference numbers in the form a:b. The a represents the reference number of the entire service assembly and the b represents a sequential number unique to each part within the service assembly.

For example, a wheel assembly might be identified by reference number 6, the tire by 6:1, the valve by 6:2, and the wheel by 6:3. When you order the assembly identified by reference number 6, you receive all parts identified by reference numbers 6:1, 6:2, and 6:3. However, you may also order any part individually. Reference numbers of this type appear in illustration and in parts lists.

Reference Numbers Indicating Quantity

In an illustration, if a reference number indicates more than one part, the reference number has the form nX y. The n represents the quantity of the part, the X is the multiplication symbol, and the y represents the reference number.

For example, in an illustration, the reference number 2X 37 means that two of the parts identified by reference number 37 are indicated.

List of Abbreviations

AR: as required	HLH: hex lag head	PTH: phillips truss head
ASM: assembly	HOC: height-of-cut	PTO: power-take-off
BBC: blade brake control	HP: high pressure	RH: right hand
BHTF: button head thread forming	HSBH: hex socket button head	ROPS: roll-over protection system
CARR: carriage	HSFH: hex socket flat head	RRB: rear roller brush
CCW: counter clockwise	HSH: hex socket head	SFH: slotted fillister head
CW: clockwise	HWH: hex washer head	SHH: slotted hex head
DEG: degrees	HWHTF: hex washer head thread forming	SHWH: slotted hex washer head
DPA: Dual Point Adjustment	HYD: hydraulic	SPH: slotted pan head
ECM: electronic control module	LH: left hand	SQH: square head
EXT: external	LP: low pressure	SRH: slotted round head
FH: flat head	LPG: Liquefied Petroleum Gas	STD: standard
GA: gauge	NI: nylon insert	TAP: self tapping
HD: heavy-duty	NPTF: national pipe thread fine	TTH: torx truss head
HF: hex flange	PFH: phillips flat head	
HH: hex head	PPH: phillips pan head	
HHF: hex head flange	PPHTF: phillips pan head thread forming	
HHFTF: hex head flange thread forming	PRH: phillips round head	
HJ: hex jam		

Touch Up Paint

Exmark black touch up spray paint – gloss black.

Exmark red touch up paint (spray paint – P/N 1-850337 - .6 oz liquid bottle – P/N 103-9140).



If your Exmark dealer does not have the Exmark part in stock, Exmark will get the parts to the dealer the next business day or the part will be FREE Guaranteed!! (Some restrictions apply. See your participating Exmark Dealer for details.)

Contents

Hood and Mounting Assembly 4
Hood Assembly No. 116-5184 5
Tube and Baffle Assembly for 116-5000 6
Tube and Frame Assembly 7
Bag Assembly No. 116-1244 8
Weight Assembly 9

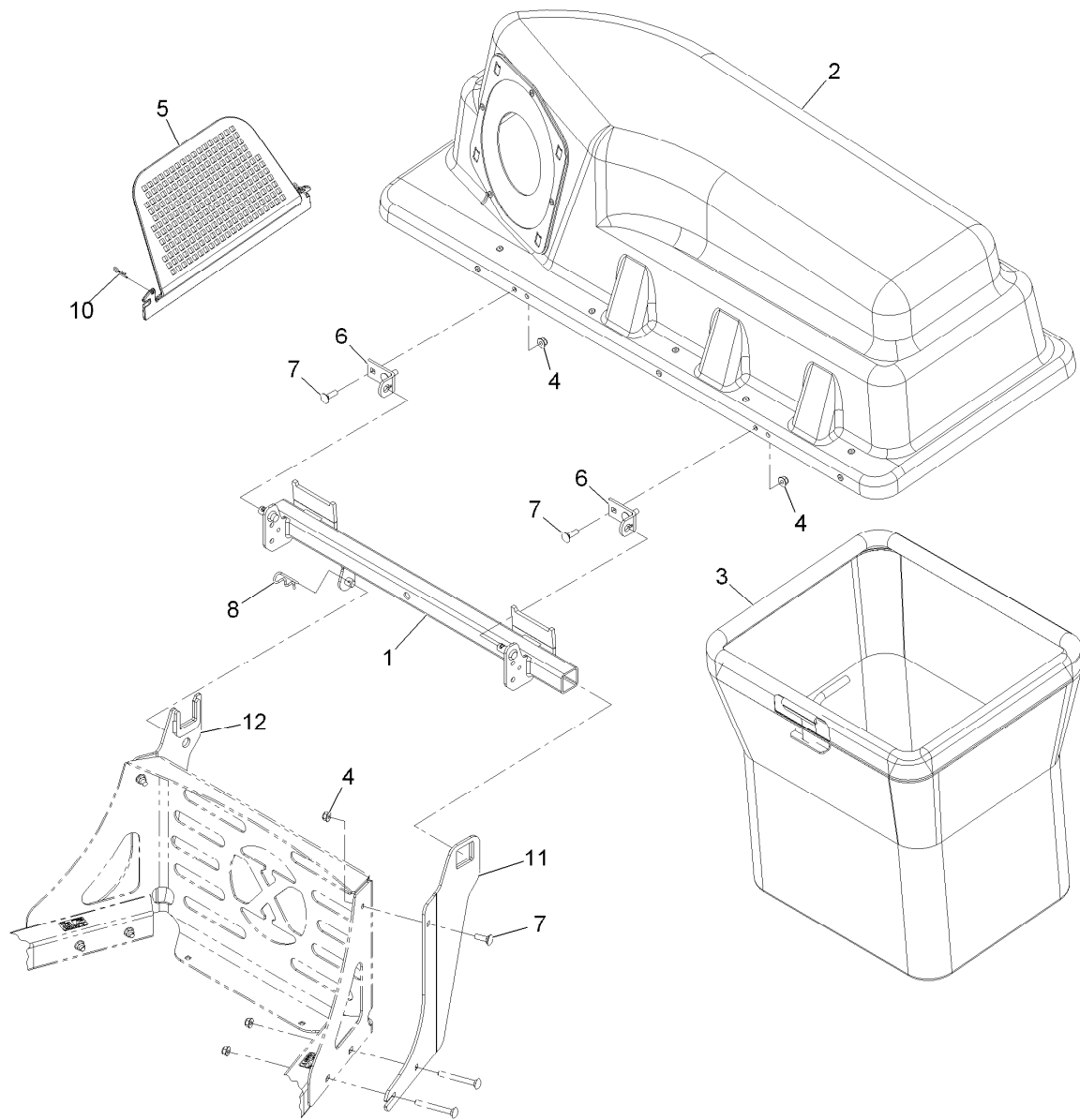

Hood and Mounting Assembly

<i>Ref.</i>	<i>Part Number</i>	<i>Qty.</i>	<i>Description</i>
1	116-4783-03	1	Frame Pivot ASM
2	116-5184	1	Bagger Hood ASM
3	116-1244	2	ASM, Bag
4	104-8300	6	Nut-Nyloc 5/16-18 Flg
5	112-3993	1	Screen-Bagger
6	112-3987	2	Bracket-Pivot, Hopper
7	3230-2	6	Bolt-Carriage 5/16-18 X 1
8	3290-355	1	Pin-Hair
10	3290-307	2	Pin-Cotter
11	116-4862-03	1	Bracket ASM, LH
12	116-4863-03	1	Bracket ASM, RH

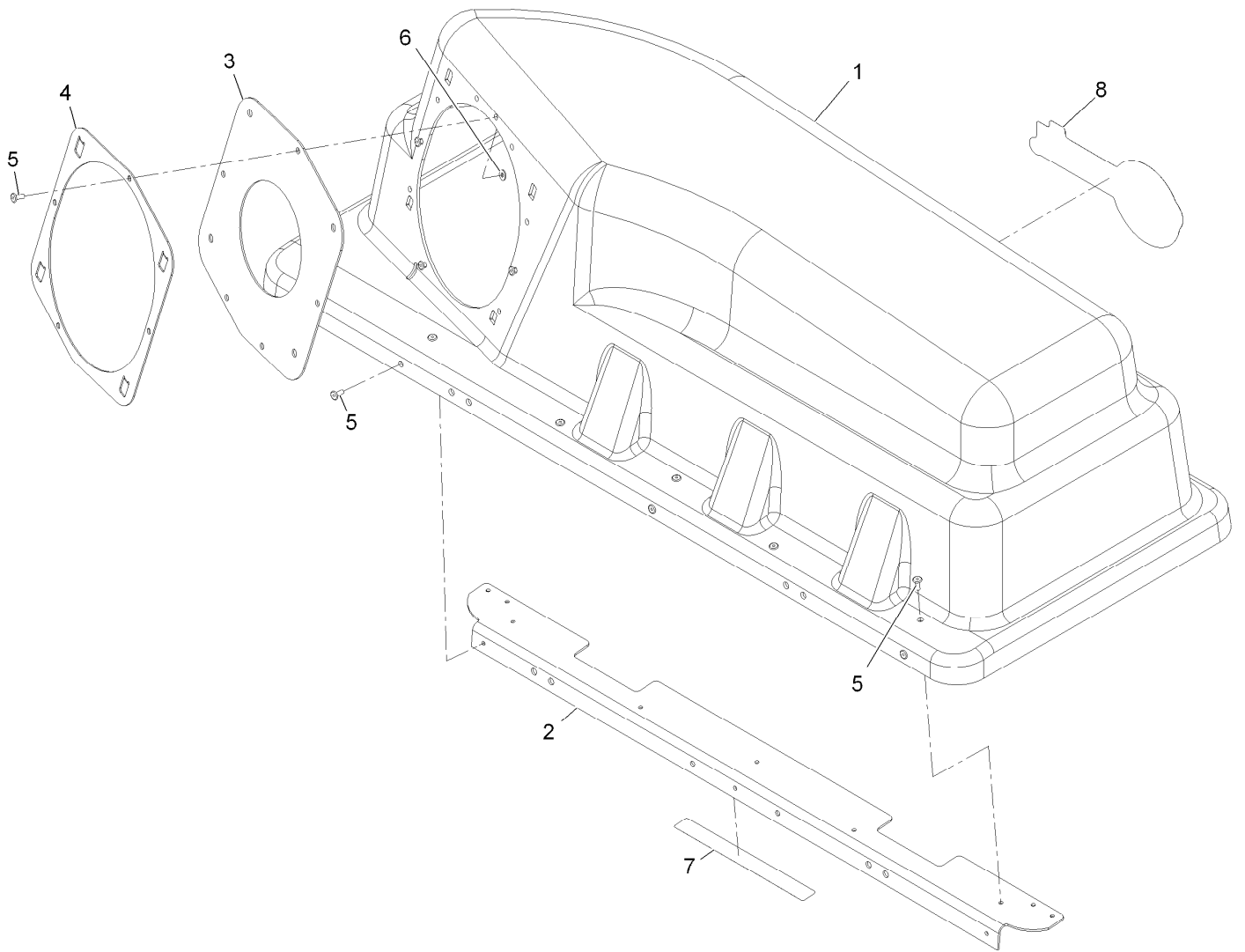

Hood Assembly No. 116-5184

<i>Ref.</i>	<i>Part Number</i>	<i>Qty.</i>	<i>Description</i>
1	112-3992	1	Top-Bagger
2	116-5071-03	1	Stiffener-Bagger, Top
3	116-4478	1	Gasket
4	112-4000-03	1	Ring-Retainer
5	114439	12	Rivet
6	9202704	4	Washer
7	109-6809	1	Decal-Caution, Bagger
8	1-653546	1	Decal, Exmark

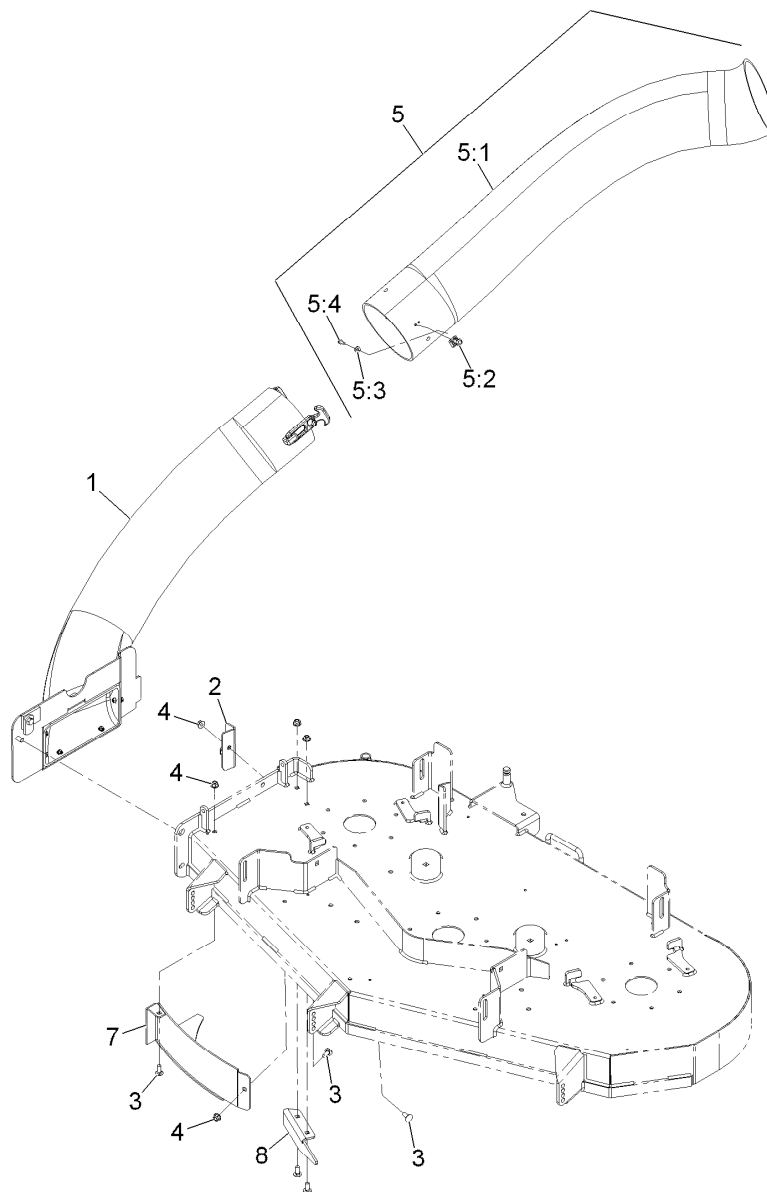

Tube and Baffle Assembly for 116-5000

Ref.	Part Number	Qty.	Description
1	116-5141	1	Tube And Frame ASM
2	109-5387-03	1	Bracket-Boot Mount, 52 Inch
2	109-6091-03	1	Bracket-Boot Mount, 48 Inch
3	3230-23	3	Bolt-Carriage 5/16-18 X 3/4 Short Neck
4	104-8300	3	Nut-Nyloc 5/16-18 Fig
5	116-5154	1	Upper Tube W/Keeper ASM
5:1	116-5153	1	Tube-Upper
5:2	103-4081	2	Latch-Keeper ●
5:3	3256-14	2	Washer-#10 Std
5:4	3290-500	2	Screw-PPH #10-24 X 5/8
7	116-1252-03	1	Wld, Discharge Baffle
8	116-5155-01	1	Baffle-Discharge

● Kit No. 103-4188 - Contains catch, rubber latch, and mounting hardware

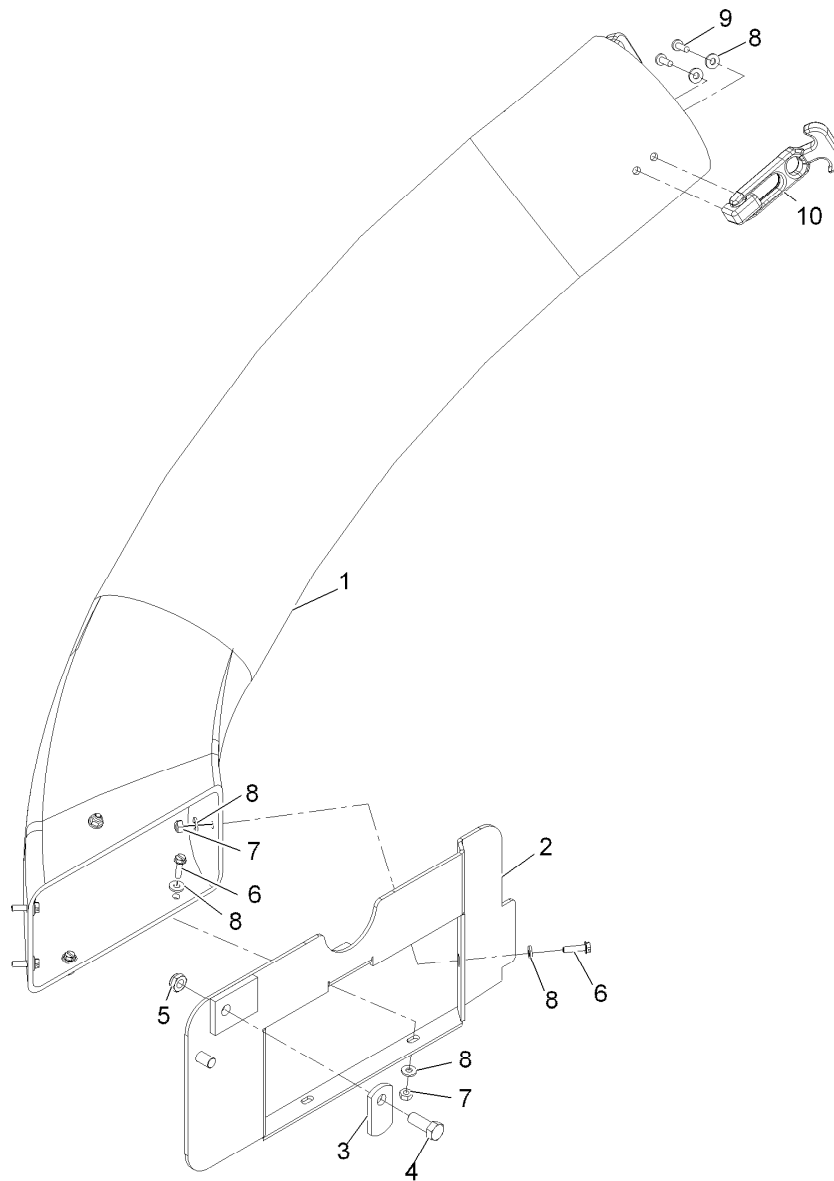

Tube and Frame Assembly

<i>Ref.</i>	<i>Part Number</i>	<i>Qty.</i>	<i>Description</i>
1	116-5140	1	Boot-Lower
2	109-6089-03	1	Boot Frame ASM
3	1-353054	1	Latch-Catcher, Grass
4	323-6	1	Screw-HH 3/8-16 X 1
5	3296-59	1	Nut-Nyloc 3/8-16 Thin
6	32105-13	6	Screw-HWH #10-24 X 3/4
7	3296-2	6	Nut-Nyloc #10-24
8	3256-14	16	Washer-#10 Std
9	3290-500	4	Screw-PPH #10-24 X 5/8
10	103-4080	2	Latch-Rubber ●

● Kit No. 103-4188 - Contains catch, rubber latch, and mounting hardware

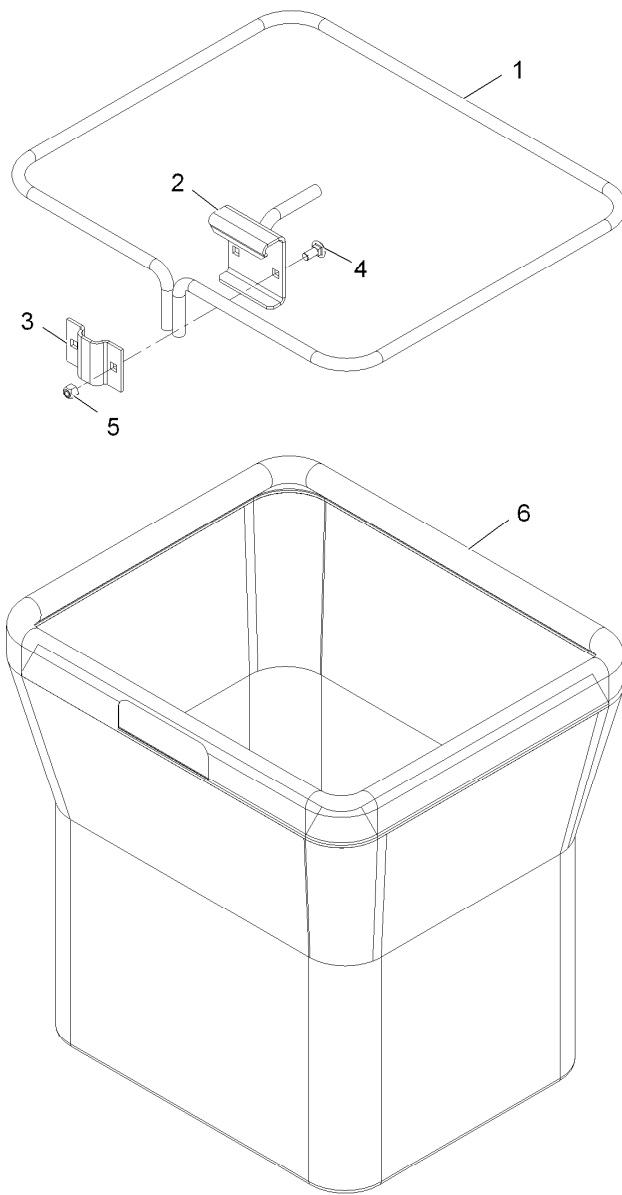

Bag Assembly No. 116-1244

<i>Ref.</i>	<i>Part Number</i>	<i>Qty.</i>	<i>Description</i>
1	114972-03	1	Frame-Bag
2	112-4012-03	1	Hanger ASM
3	114974-03	1	Clamp
4	3230-1	2	Bolt-Carriage 5/16-18 X 3/4
5	3296-29	2	Nut-Nyloc 5/16-18
6	116-1209	1	Bag,20 In. Depth

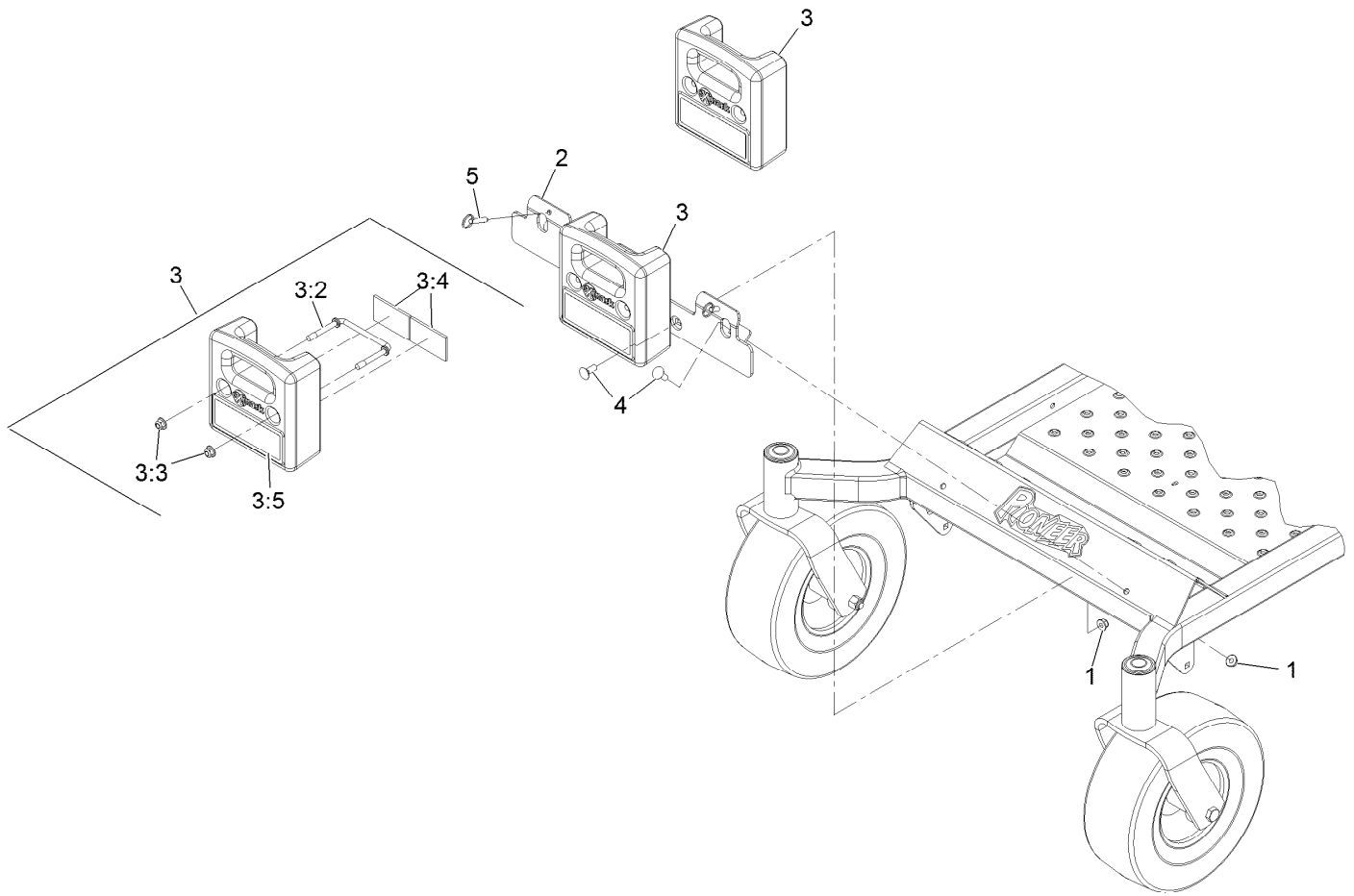

Weight Assembly

Ref.	Part Number	Qty.	Description
1	104-8301	4	Nut-Flange, NI
2	116-5181-01	1	Three Weight ASM
3	116-4472	3	Weight ASM
3:2	116-4471	1	Wireform-Weight
3:3	104-8301	2	Nut-Flange, NI
3:4	100-6547	2	Cushion-Rubber
3:5	126-4661	1	Decal-Warning Weight
4	3231-2	4	Bolt-CARR
5	115-1556	3	Pin-Ball, Detent

Notes:

Notes:

EXMARK ACCESSORIES AND OPTIONS*

MID-MOUNT RIDING ACCESSORIES AND OPTIONS

CUSTOM RIDE SEAT SUSPENSION SYSTEM	OPERATOR CONTROLLED DISCHARGE
FULL SUSPENSION SEAT	SUN SHADE
DECK LIFT ASSIST KIT	TRASH CONTAINER
HITCH KIT	TURF STRIPER
LIGHT KIT	ULTRA VAC COLLECTION SYSTEM
12V POWER PORT	ULTRA VAC QUICK DISPOSAL SYSTEM
MICRO-MULCH SYSTEM	

OUT-FRONT RIDING ACCESSORIES AND OPTIONS

CUSTOM RIDE SEAT SUSPENSION SYSTEM	SNOW BLADE
DUAL-TAIL WHEEL	SNOWBLOWER
FLOOR PAN EXTENDER	SUN SHADE
HITCH KIT	TRASH CONTAINER
LIGHT KIT	ULTRA VAC COLLECTION SYSTEM
MICRO-MULCH SYSTEM	ULTRA VAC QUICK DISPOSAL SYSTEM
ROLL OVER PROTECTION SYSTEM (ROPS)	WEATHER CAB

WALK-BEHIND ACCESSORIES AND OPTIONS

GRASS CATCHER	TURF STRIPER
MICRO-MULCH SYSTEM	STANDON

*Some accessories and options not available for some models.

Place Model No. and Serial No.
Label Here (Included in the Literature
Pack) or Fill in Below

Model No. _____

Serial No. _____

Date Purchased _____

Engine Model No. and Spec. No. _____

Engine Serial No. (E/No) _____

© 2015 Exmark Mfg. Co., Inc.
Industrial Park Box 808
Beatrice, NE 68310
All Rights Reserved

Part No. 4502-261 Rev. A
(402) 223-6300
Fax (402) 223-5489
Printed in the USA.

