



MODEL NO. 04375 — 40001 &amp; UP

## OPERATOR'S MANUAL

### GREENSMASTER® 3000-D TRACTION UNIT



The GREENSMASTER 3000-D conforms to the American National Standards Institute's safety standards for riding mowers; thus Toro proudly displays the ANSI safety seal.

To achieve maximum safety, optimum performance, and to gain knowledge of the machine, it is essential that you or any other operator of the machine read and understand the contents of this manual before the engine is started. Pay particular attention to the instructions highlighted by the  the instructions highlighted by the triangular safety alert symbol. Failure to comply with the safety instructions may result in personal injury.

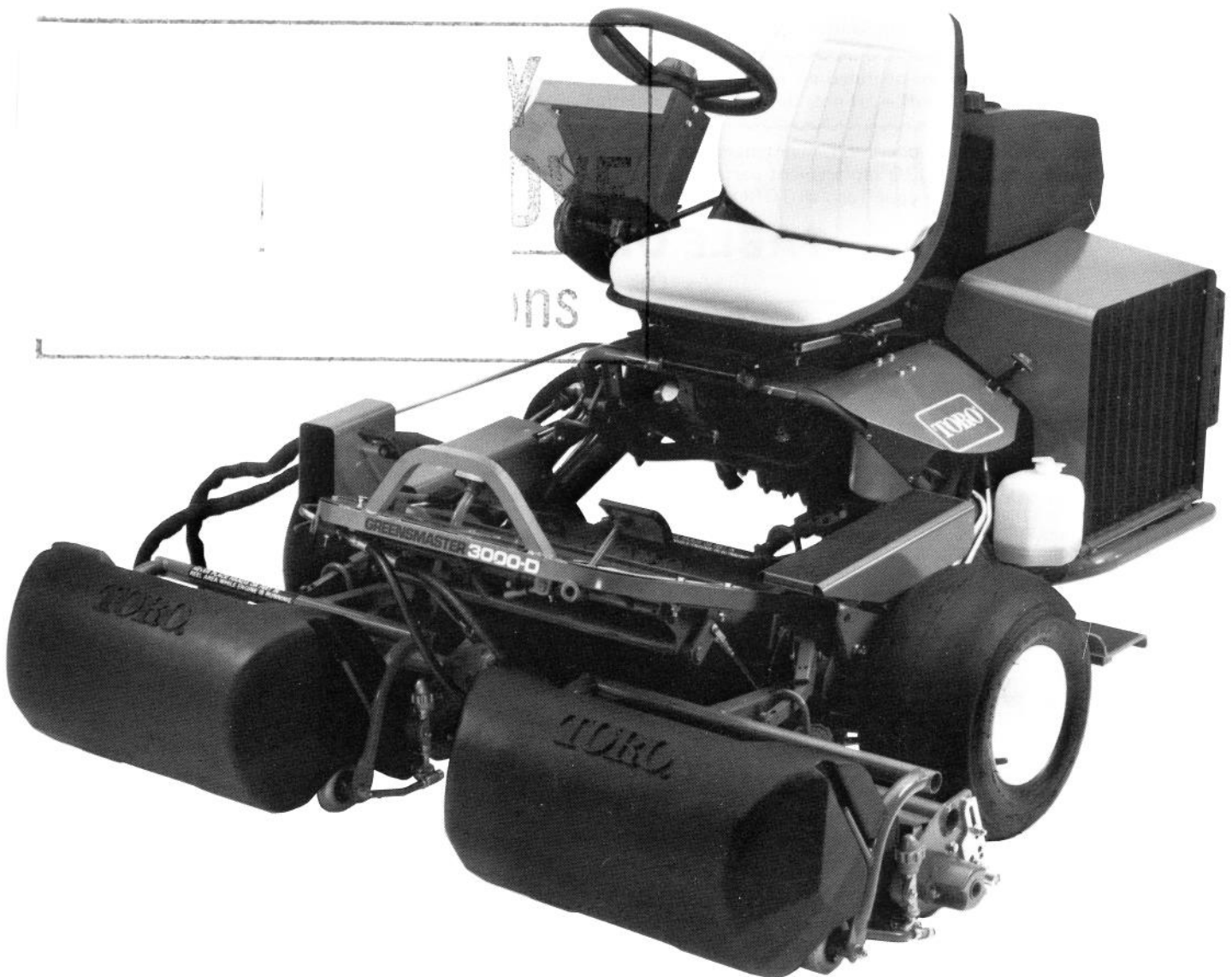

# FOREWORD

Your New GREENSMaster 3000-D was developed to provide an efficient, troublefree and time-saving method of mowing high quality turf on the finest greens. The latest concepts in engineering, design and safety have been incorporated into this machine along with the highest quality parts and workmanship. Excellent service will be derived if proper operation and maintenance practices are followed.

We know, since you have purchased the industry leader in mowing excellence, that future performance and dependability are of prime importance. TORO also is concerned about future use of the machine and of safety to the user. Therefore, this manual should be read by you and those involved with the GREENSMaster 3000-D to make sure that safety, proper set-up, operation and maintenance procedures are followed at all times. The major sections of the manual are:

- |                                  |                           |                     |
|----------------------------------|---------------------------|---------------------|
| 1. Safety Instructions           | 3. Before Operating       | 5. Maintenance      |
| 2. General Assembly Instructions | 4. Operating Instructions | 6. Trouble Shooting |

Safety, mechanical and some general information in this manual is emphasized. DANGER, WARNING and CAUTION identify safety messages. Whenever the triangular safety symbol appears, it is followed by a safety message that must be read and understood. For more details concerning safety, read the safety instructions on pages 3, 4 and 5. IMPORTANT identifies special mechanical information and NOTE identifies general information worthy of special attention.

## SERVICE MANUAL

A Service Manual is available for the Greensmaster 3000-D. This publication provides information for troubleshooting, adjusting, testing and repair of major systems and components on the machine. To order this publication, contact your local authorized Toro Distributor. Ask for Form 89-740-ST, Greensmaster 3000-D Service Manual.

## OPTIONAL SPARK ARRESTER

In some areas there are local, state or federal regulations requiring that a spark arrester be used on the engine of this mower. If a spark arrester is required, order the following parts from your local TORO Distributor:

- (1) 70-8550 Spark Arrester Assembly

These parts are approved by the United States Department of Agriculture and the United States Forest Service.

When mower is used or operated on any California forest, brush or grass covered land, a working order spark arrester must be attached to muffler. If not, the operator is violating state law, Section 442 Public Resources Code.

If help concerning set-up, operation, maintenance or safety is ever needed, contact the local Authorized TORO Distributor. In addition to genuine TORO replacement parts, the distributor also has optional equipment for the complete line of TORO turf care equipment. Keep your Toro all TORO. Buy genuine TORO parts and accessories.

# TABLE OF CONTENTS

	Page		Page
SAFETY INSTRUCTIONS .....	3-4	Servicing Dust Cup and Baffle .....	21
SAFETY AND INSTRUCTION DECALS .....	4-6	Servicing Air Cleaner Filter .....	22
LOOSE PARTS CHART .....	6	Inspecting Filter Element .....	22
SPECIFICATIONS .....	7	Clean Radiator and Screen .....	23
SET-UP INSTRUCTIONS .....	8-11	Changing Crankcase Oil and Filter .....	23
Remove, Activate and Charge Battery .....	8	Servicing Fuel System .....	23-24
Install Rear Wheel Assembly .....	8	Bleeding Air From Injectors .....	24-25
Install Battery .....	8	Servicing Engine Belts .....	25
Mount Steering Assembly .....	9	Changing Coolant in Cooling System .....	25
Install Steering Wheel .....	9	Servicing the Pull Frame and Roller Assembly .....	26
Install Seat .....	9	Brake Adjustment .....	26
Install Cutting Units .....	9-10	Servicing Battery .....	27
BEFORE OPERATING .....	11-13	Electrical Switch Servicing .....	27
Add Engine Oil .....	11	General Switch Maintenance .....	27
Check Cooling System .....	11	Seat Switch Removal, Installation and Adjustment .....	27
Fill Fuel Tank with Diesel Fuel .....	11	Traction Switch Removal, Installation and Adjustment .....	28
Check Hydraulic System .....	12	Mow/Lift Switch Removal, Installation and Adjustment .....	28
Tire Pressure .....	13	Wiring Harness Service .....	28
CONTROLS .....	13-15	ELECTRICAL SCHEMATIC .....	29
PRE-OPERATING INSTRUCTIONS .....	15-18	TROUBLESHOOTING .....	29-31
Break-In Period .....	15	MAINTENANCE .....	32-35
Starting/Stopping Engine .....	15	Servicing the Hydraulic System .....	32
Bleeding Fuel System .....	16	Servicing Cutting Unit .....	32
Initial Pre-Operating Check .....	17	Draining Reservoir (Fig. 4-5) .....	32
Check Interlock Switches .....	17	Fluid Contamination Due to Component Failure .....	33
Preparing Machine for Mowing .....	18	Hydraulic Filter (Fig. 46) .....	33
Training Period .....	18	Rear Camshaft Adjustment .....	33
OPERATING INSTRUCTIONS .....	18-19	Adjusting Lift and Mow Pedal Height .....	34
Before Mowing .....	18	Adjusting Cutting Unit Lift/Drop .....	35
Mowing Procedures .....	18	Adjusting Lift Cylinders .....	35
Transport Operation .....	19	HYDRAULIC SCHEMATIC .....	35
Inspection and Clean-up After Mowing .....	19	TROUBLESHOOTING .....	36-38
LUBRICATION .....	19	STORAGE INSTRUCTIONS .....	39
SERVICE INTERVAL CHART .....	21	IDENTIFICATION AND ORDERING .....	39
MAINTENANCE .....	21-38	TORO PROMISE .....	40
General Maintenance Practices .....	21		

COPYRIGHT © ALL RIGHTS RESERVED

©The Toro Company — 1993

MINNEAPOLIS, MN 55420 — U.S.A.

# SAFETY INSTRUCTIONS



This safety alert symbol means **CAUTION, WARNING or DANGER** — "personal safety instruction". Read and understand the instruction because it has to do

with safety. Failure to comply with the instruction may result in personal injury.

The Greensmaster 3000-D was tested and certified by TORO for compliance with the American National Standards Institutes Specification B71.4 — 1990. Although hazard control and accident prevention partially are dependent upon the design and configuration of the machine, these factors are also dependent upon the awareness, concern, and proper training of the personnel involved in the operation, transport, maintenance, and storage of the machine. Improper use or maintenance of the machine can result in injury or death. To reduce the potential for injury or death, comply with the following safety instructions.

**WARNING:** Engine exhaust contains carbon monoxide which is an odorless, deadly poison. Carbon monoxide is also known to the State of California to cause birth defects. Do not run engine indoors or in an enclosed area.

## BEFORE OPERATING

1. Read and understand the contents of this Operator's Manual before starting and operating the machine. Become familiar with all controls and know how to stop quickly. A replacement manual is available by sending complete Model and Serial Number to:

The Toro Company  
8111 Lyndale Avenue South  
Minneapolis, Minnesota 55420-1196

2. Never allow children to operate the machine. Do not allow adults to operate machine without proper instruction. Only trained operators who have read this manual should operate this machine.

3. Never operate the machine when under the influence of drugs or alcohol.

4. Become familiar with the controls and know how to stop the engine quickly.

5. Keep all shields, safety devices and decals in place. If a shield, safety device or decal is malfunctioning, illegible or damaged, repair or replace it before operating the machine.

6. Always wear substantial shoes. Do not operate machine while wearing sandals, tennis shoes or sneakers. Do not wear loose fitting clothing because it could get caught in moving parts and possibly cause personal injury.

7. Wearing safety glasses, safety shoes, long pants and a helmet is advisable and required by some local ordinances and insurance regulations.

8. Make sure work area is clear of objects which might be picked up and thrown by the reels.

9. Do not carry passengers on the machine, and keep everyone, especially children and pets, away from the areas of operation.

10. Since diesel fuel is highly flammable, handle it carefully.

A. Use an approved fuel container.

B. Do not remove cap from fuel tank when engine is hot or running.

C. Do not smoke while handling fuel.

D. Fill fuel tank outdoors and not over one inch (25 mm) from the top of the tank, not the filler neck. Do not overfill.

E. Wipe up any spilled fuel.

## WHILE OPERATING

11. Do not run the engine in a confined area without adequate ventilation. Exhaust fumes are hazardous and could be deadly.

12. Seating capacity is one person. Therefore, never carry passengers.

13. Sit on the seat when starting and operating the machine.

14. Check the safety interlock switches daily for proper operation; refer to page 17. If a switch should fail, replace the switch before operating the machine. **(After every two years, replace all three interlock switches in the safety system, regardless if they are working properly or not.)**

15. To start the engine:

A. Sit on the seat, depress lift pedal and release it to disengage cutting units.

B. Verify that traction system is in neutral.

C. Verify that parking brake is set.

D. Proceed to start engine. Do not use ether or other type starting fluids to start engine.

16. Using the machine demands attention, and to prevent loss of control:

A. Mow only in daylight or when there is good artificial light.

B. Watch for holes or other hidden hazards.

C. Do not drive close to sand traps, ditches, creeks or other hazards.

D. Reduce speed when making sharp turns. Avoid sudden stops and starts.

E. Before backing up, look to the rear to be sure no one is behind the machine.

F. Watch out for traffic when near or crossing roads. Always yield the right-of-way.

# SAFETY INSTRUCTIONS

- G. Apply the service brakes when going downhill to keep forward speed slow and to maintain control of the machine.
17. This product may exceed noise levels of 85 dB(A) at the operator position. Ear protectors are recommended, for prolonged exposure, to reduce the potential of permanent hearing damage.
18. Keep hands, feet and clothing away from moving parts and the reel discharge area. The grass baskets must be in place during operation of the reels or thatchers for maximum safety. Shut the engine off before emptying the baskets.
19. Raise the cutting units when driving from one work area to another.
20. Do not touch engine, muffler or exhaust pipe while engine is running or soon after it is stopped because these areas could be hot enough to cause burns.
21. If a cutting unit strikes a solid object or vibrates abnormally, stop immediately, turn engine off, wait for all motion to stop and inspect for damage. A damaged reel or bedknife must be repaired or replaced before operation is continued.
22. Before getting off the seat:
- A. Move shift selector to N — neutral.
  - B. Depress the lift pedal to raise the cutting units, wait for the reels to stop spinning and release lift pedal.
  - C. Set the parking brake.
  - D. Stop the engine and remove key from ignition switch.
23. Traverse slopes carefully. Do not start or stop suddenly when traveling uphill or downhill.
24. Operator must be skilled and trained in how to drive on hillsides. Failure to use caution on slopes or hills may cause loss of control and vehicle to tip or roll possibly resulting in personal injury or death.
25. If engine stalls or loses headway and cannot make it to the top of a slope, do not turn machine around. Always back slowly straight down the slope.
26. **DON'T TAKE AN INJURY RISK!** When a person or pet appears unexpectedly in or near the mowing area, **STOP MOWING**. Careless operation, combined with terrain angles, ricochets, or improperly positioned guards can lead to thrown object injuries. Do not resume mowing until area is cleared.
27. Whenever machine is left unattended, make sure cutting units are fully raised and reels are not spinning, key is removed from ignition switch and parking brake is set.

## MAINTENANCE

28. Before servicing or making adjustments to the machine, stop the engine and remove key from switch to prevent accidental starting of the engine.
29. Be sure entire machine is in good operating condition. Keep all nuts, bolts, screws and hydraulic fittings tight.
30. Make sure all hydraulic line connectors are tight, and all hydraulic hoses and lines are in good condition before applying pressure to the system.
31. Keep body and hands away from pin hole leaks or nozzles that eject hydraulic fluid or diesel fuel under high pressure. Use paper or cardboard, not hands, to search for leaks. Hydraulic fluid or diesel fuel escaping under pressure can have sufficient force to penetrate skin and do serious damage. If fluid is injected into the skin it must be surgically removed within a few hours by a doctor familiar with this form of injury or gangrene may result.
32. Before disconnecting or performing any work on the hydraulic or engine fuel system, all pressure in system must be relieved by stopping engine and lowering implement to the ground.
33. If major repairs are ever needed or if assistance is desired, contact an Authorized Toro Distributor.
34. To reduce potential fire hazard, keep the engine area free of excessive grease, grass, leaves and accumulation of dirt.
35. If the engine must be running to perform a maintenance adjustment, keep hands, feet, clothing and other parts of the body away from the cutting units and other moving parts. Keep everyone away.
36. Do not overspeed the engine by changing governor settings. To assure safety and accuracy, have an Authorized Toro Distributor check maximum engine speed with a tachometer. Maximum governed engine speed should be 2800 +0 – 50 RPM.
37. Engine must be shut off before checking oil or adding oil to the crankcase. Because the cooling system becomes pressurized during operation, allow the engine to cool before removing the radiator cap.
38. At the time of manufacture, the GREENS-MASTER 3000-D conformed to safety standards in effect for riding mowers. To make sure of optimum performance and continued safety certification of the machine, use genuine TORO replacement parts and accessories. Replacement parts and accessories made by other manufacturers could be dangerous, and such use could void the product warranty of The Toro Company.

# SAFETY AND INSTRUCTION DECALS



The following safety and instruction decals are installed on the traction unit. If any become damaged or illegible, replace them. Decal part numbers are listed below and in your Parts Catalog. Order replacements from your Authorized Toro Distributor.

## TO LOCK PARKING BRAKE

1. DEPRESS BRAKE PEDAL.
2. DEPRESS LATCH AND RELEASE BRAKE PEDAL.

TO RELEASE PARKING BRAKE, DEPRESS BRAKE PEDAL.



ABOVE PARKING BRAKE LATCH PEDAL  
(Part No. 27-2830)



**HYDRAULIC OIL ONLY**  
USE MOBIL DTE 26 OR SHELL TELLUS 68

ON HYDRAULIC TANK NEAR OIL FILL CAP  
(Part No. 58-6530)

ON STEERING CONTROL ARM  
(Part No. 75-9380)

## CAUTION

CHECK PERFORMANCE OF ALL THREE INTERLOCK SWITCHES DAILY. SEE OPERATORS MANUAL FOR INSTRUCTION. DO NOT DEFEAT INTERLOCK SYSTEM. IT IS FOR YOUR PROTECTION. KEEP BYSTANDERS AWAY FROM AREA BEING MOWED. APPLY BRAKES WHEN TRAVELING DOWNHILL TO KEEP FORWARD SPEED SLOW AND MAINTAIN VEHICLE CONTROL. BEFORE LEAVING OPERATOR SEAT POSITION: ASSURE CUTTING UNITS ARE IN FULLY RAISED POSITION AND REELS ARE NO LONGER SPINNING. PLACE TRANSMISSION IN "NEUTRAL" POSITION. SET PARKING BRAKE. STOP ENGINE AND REMOVE KEY.

READ AND UNDERSTAND OPERATORS MANUAL BEFORE OPERATING THIS MACHINE. REPLACEMENT MANUAL AVAILABLE BY SENDING ENTIRE MODEL NUMBER TO: THE TORO CO. 8111 LYNDALE AVE. SO. MINNEAPOLIS, MINN. 55420

75-9380

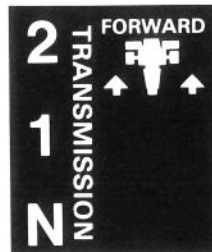

ON RIGHT HAND SHIELD  
(Part No. 51-0010)

ON HOOD  
(Part No. 54-0910)



ON FRAME TUBE  
(Part No. 88-1270)



DEPRESS LIFT PEDAL TO DISENGAGE DEPRESS MOW PEDAL TO ENGAGE

BELOW MOW AND LIFT PEDALS  
(Part No. 51-0050)



ON CUTTING UNIT PULL FRAMES  
(Part No. 62-5070)

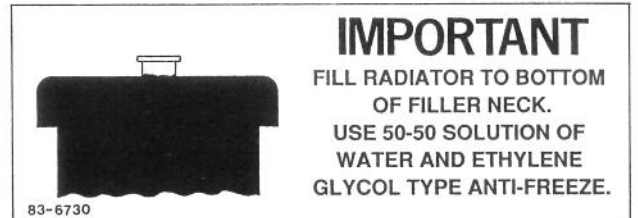

ON TOP OF RADIATOR HOOD  
(Part No. 83-6730)



ON HYDRAULIC TANK  
(Part No. 66-6840)

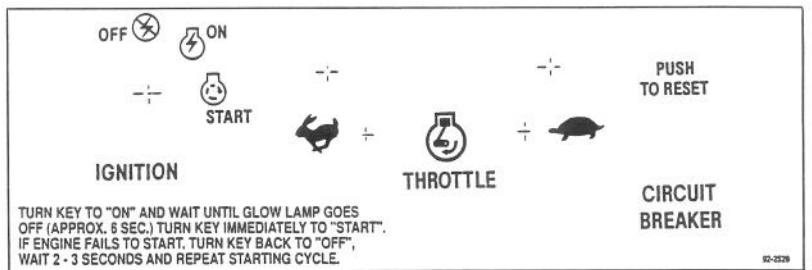

ON STEERING ARM  
(Part No. 92-2529)



AIR CLEANER  
(Part No. 67-1700)



ON HOOD ALONGSIDE MUFFLER  
(Part No. 63-8440)



ON FAN SHROUD  
(Part No. 76-8750)

# SAFETY AND INSTRUCTION DECALS

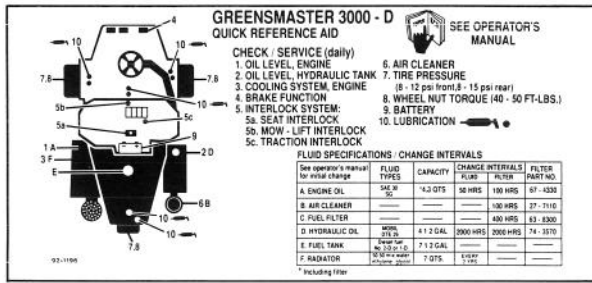

**ON SEAT BACK**  
**(Part No. 92-1196)**

## LOOSE PARTS CHART

LOOSE PARTS	QTY.	DESCRIPTION	WHERE USED
Seat	1		
Hex Nut	4	5/16-18	Mount seat slides to seat base
Rear Wheel Assembly	1		Install in castor fork shaft.
Spacer	2		
Pivot Bolt	1		Install in steering arm.
Washer	1		Install on pivot bolt in steering arm.
Wear Plate	2		
Friction Washer	4		
Lock Lever	1		
Arm Locking Hub	1		
Set Screw	1		Install in arm locking hub.
Cap	1		Install on steering column.
Fillister Head Screw	1		
Steering Wheel	1		
Nut	1		Install Steering Wheel
Grass Basket	3		Mount to pull frames.
Gauge Bar	1		Adjusts height-of-cut - Cutting units.
Machine Screw	1	#10 - 32 x 5/8" lg.	Assemble to gauge bar.
Jam Nut	1	#10	
Operator's Manual (Traction Unit)	2		
Parts Catalog (Traction - Cutting Unit)	1		
Set-Up Report Card	1		
Cutting Unit Set-Up Card	1		
Registration Card	1		Send to The Toro Co. Registers machine.

**Note:** Mounting fasteners for Greensmaster 3000-D cutting units included with the cutting units.

# SPECIFICATIONS\*

**Configuration:** Conforms to ANSI B71-4 — 1990 specifications. Tricycle vehicle with front two wheels providing drive and rear wheel steering. Operator sits in center over No. 1 cutting unit with No. 2 and 3 cutting units at front of vehicle.

**Power:** 4-cycle, 17.0 hp (12.7 kw) liquid cooled, 3 cylinder, vertical overhead valve diesel engine. Maximum governed engine speed (no load): 2800 +0 - 50 rpm.

**Engine Oil Capacity:** 3.8 qt (3.6 l) w/o filter.

**Engine Oil Filter:** Replaceable, full flow, spin-on type. Toro Part No. 67-4330. Filter capacity: 0.528 qt (0.5 l).

**Air Cleaner:** Heavy duty remote.

## Cooling System:

Radiator — Approx. 3.5 qt (3.31 l) capacity.  
Expansion Tank — Remote mounted; 1 qt (0.946 l) capacity. System contains a 50/50 mix of ethylene glycol anti-freeze and water.

## Drive:

Traction — All hydraulic drive consisting of multiple stack pump, valve and two low speed, high torque gear motors to drive front wheels.

Cutting Units — All hydraulic drive consisting of three gear pump sections, three valve sections and three gear motors which drive the reels.

**Power Steering:** Steering valve and cylinder operated by a separate section of the fixed displacement hydraulic gear pump.

**Hydraulic Filter:** 10 micron, cartridge type w/905 in.<sup>2</sup> (5838 cm<sup>2</sup>) filter area for extra long life.

**Hydraulic Oil Reservoir:** 4.5 gal (17.03 l) capacity with internal baffle to promote cooling. Fluid used: Mobil DTE 26 or Shell Tellus 68. Red Dye added to oil.

**Fuel Tank:** 7.5 gal (28.4 l) capacity.

**Fuel System:** Includes a fuel filter/water separator and 12 volt electric (transistor type) fuel pump with replaceable fuel filter.

**Electrical & Instrumentation:** Has ammeter, hour-meter, coolant temperature gauge and 4 bank warning lamp cluster. Electrical system has 40 Amp alternator, 40 Amp self resetting circuit breaker for glow circuit protection and 15 Amp resettable circuit breaker on control panel. Removable panel for easy access to electrical components.

**Interlock Switches:** Prevents engine starting if shift selector, or mow/lift systems are engaged. Stops engine if operator leaves seat with either traction selector or mow/lift pedal engaged.

**Controls:** Hand operated ignition switch, throttle, gear selector and steering control arm quick adjust lever. Foot operated traction drive. Brakes and mow/lift pedal.

**Seat Adjustment:** 4 in. (10.1 cm) forward and rearward. Can be adjusted to achieve an additional 2-1/2 in. (64 mm).

**Brakes:** 6 in. (15.2 cm) drum-type mechanical with rack and pawl lock for parking.

## Tire Pressure:

Front — 8-12 psi (55.2 - 82.7 kPa).

Rear — 8-15 psi (55.2 - 103.4 kPa).

## Wheel Bearings:

Drive Wheels — Needle provided in wheel motors.  
Rear Caster Wheel — Timken tapered roller.

## General Specifications:

Width of Cut — 59 in. (149 cm).

Wheel Tread — 49-1/2 in. (125 cm).

Wheel Base — 49 in. (124 cm).

Overall Length — 91 in. (231 cm).

Overall Width — 69-3/4 in. (177 cm).

Overall Height — 50-1/4 in. (127 cm).

Net Weight (Wet) — 1233 lb (559 kg).

Shipping Weight — 1478 lb (670 kg).

Speeds @ 2800 engine rpm: (Approx.)

1st — 3.8 mph (6.1 km/hr).

2nd — 7.4 mph (11.9 km/hr).

Rev. — 1.9 mph (3.1 km/hr).

Engine Idle Speed — 1700 rpm. +50 -0

Reels — 1940 rpm.

Clip — (8 blade c.u.) 0.25 in. (6.3 mm).

Battery — 12 volt, BCI group size 26, maintenance free with 530 cranking apms at 0°F.

Size: Length — 7-1/4 in. (18.4 cm).

Width — 4.88 in. (12.4 cm).

Height — 6.00 in. (12.2 cm).

## Accessories:

5 Blade, 4 Bolt Cutting Unit, Model 04405

8 Blade, 4 Bolt Cutting Unit, Model 04408

11 Blade, 4 Bolt Cutting Unit, Model 04406

8 Blade, SPA Cutting Unit, Model 04468

11 Blade, SPA Cutting Unit, Model 04450

8 Blade, SPA Cutting Unit w/Groomer, Model 04460

11 Blade, SPA Cutting Unit w/Groomer, Model 04465

Thatching Reels, Model No. 04416.

Spiker Attachment, Model No. 04420.

Variable Traction Speed Kit, Model No. 04422.

Individual Reel Shut Off Kit, Part No. 28-2150.

Basket Reinforcement Kit, Part No. 26-0900.

Backlapping Kit, Part No. 63-4960.

\*Specifications and design subject to change without notice.

# SET-UP INSTRUCTIONS

## REMOVE, ACTIVATE AND CHARGE BATTERY

1. Remove battery clamp and lift out battery.



### WARNING

Electrolyte gases are explosive and can cause serious injury to eyes, lungs and skin. Wear safety goggles and rubber gloves when working with electrolyte or battery. Charge the battery in a well ventilated place so gasses produced while charging can dissipate. Since the gases are explosive, keep open flames and electrical spark away from the battery; do not smoke. Nausea may result if the gases are inhaled. Unplug charger from electrical outlet before connecting to or disconnecting charger leads from battery posts.

2. Remove filler caps from battery and slowly fill each cell until electrolyte is up to fill line.
3. Replace filler caps and connect a battery charger to the battery posts. Charge the battery at a rate of 3 to 4 amperes for 4 to 8 hours.
4. When battery is charged, disconnect charger from electrical outlet and battery posts, and allow battery to sit for 5-10 minutes.
5. Remove filler caps. Slowly add electrolyte to each cell until level is up to fill line. Install filler caps.

**IMPORTANT: Do not overfill battery. Electrolyte will overflow onto other parts of the machine and severe corrosion and deterioration will result.**

## INSTALL REAR WHEEL ASSEMBLY

1. Remove bolt and locknut from the wheel mount holes in the rear castor fork (Fig. 1).

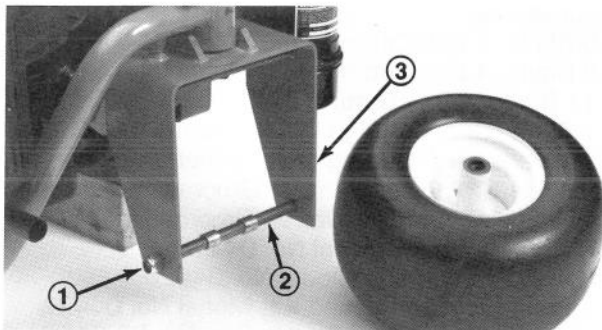

Figure 1

1. Locknut 2. Bolt 3. Castor fork

2. Install the rear wheel in the castor fork. Insert the bolt into one of the mounting holes, install a spacer and slide the bolt through the wheel (Fig. 2).

3. Install another spacer onto the bolt and route the bolt through the remaining castor fork mounting hole (Fig. 2).

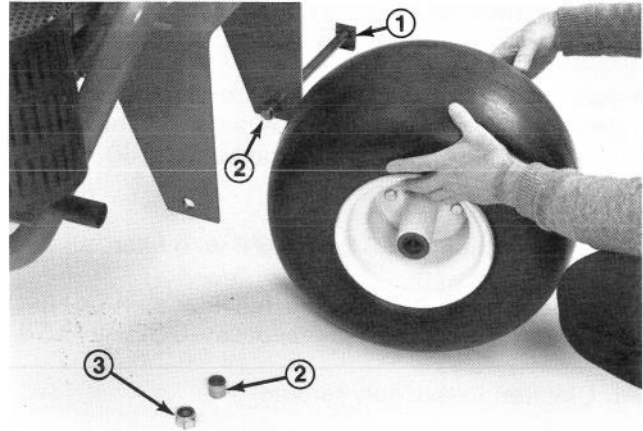

Figure 2

1. Bolt 2. Spacer 3. Locknut

4. Position the bend of the bolt head under the bottom edge of the castor fork. Install and tighten the locknut to secure the wheel to the castor fork.

5. Wipe grease fitting clean on wheel assembly. Pump grease into wheel hub until grease is seen exiting at both hub bearings, thus assuring wheel hub cavity is full. Wipe up excess grease.

## INSTALL BATTERY

1. Mount battery with battery terminals toward the front of Greensmaster 3000-D (Fig. 3).
2. Connect the positive battery cable (red) to the positive post (+) of the battery. Secure with wrench and coat terminal with petroleum jelly.



### WARNING

Connecting cables to the wrong post could result in personal injury and/or damage to the electrical system. Make sure battery or cables do not interfere or rub on any moving or hot parts.

3. Connect the black ground cable to the negative (-) post of the battery. Secure with wrench and coat terminal with petroleum jelly.

4. Install battery clamp.

5. Place terminal cover over positive (+) battery post.

# SET-UP INSTRUCTIONS

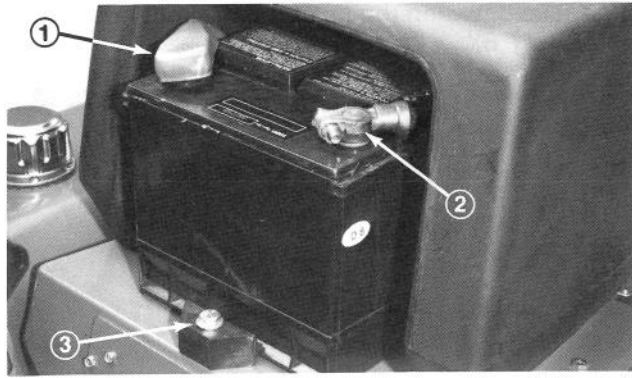

Figure 3

1. Positive (+) 2. Negative (-) 3. Battery clamp assembly

## MOUNT STEERING ASSEMBLY

1. Install a flat washer, friction washer and wear plate onto the large capscrew for the steering control arm.
2. Raise the control arm. Insert a friction washer between the outside part of the mounting frame and control arm (Fig. 4). Align the holes and, from outside toward the inside, slide the capscrew through the outside mounting frame hole, the friction washer and outside control arm hole (Fig. 4).
3. Slip the arm locking hub onto the capscrew and install a friction washer between the inner portion of the control arm and the mounting frame (Fig. 4). Slide the capscrew through the inner control arm hole, the friction washer and inside mounting frame hole (Fig. 4).
4. Insert a wear plate and friction washer between the frame mounting bracket and steering arm plate. Slide the capscrew completely through all three parts (Fig. 4).
5. Thread the capscrew into the arm lock lever and hold the arm in its highest position. With the lever in locked position (fully back against the rear stop), torque the capscrew to 35 ft-lb (47 N·m). Thread a set screw into the arm locking hub, slide the hub against the right side of the control arm and tighten the set screw (Fig. 4).

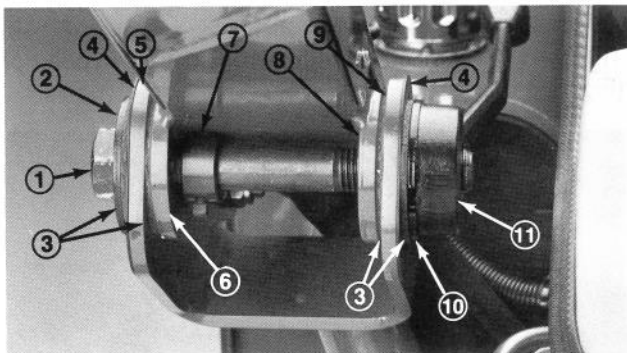

Figure 4

- |                                |                               |
|--------------------------------|-------------------------------|
| 1. Capscrew                    | 7. Arm locking hub            |
| 2. Flatwasher                  | 8. Inside control arm bracket |
| 3. Friction washer (4)         | 9. Inside mounting frame      |
| 4. Wear plate                  | 10. Steering arm plate        |
| 5. Outside mounting frame      | 11. Arm lock lever            |
| 6. Outside control arm bracket |                               |

6. Check the control arm adjustment. With the arm locked in highest position, apply approximately 200 lb (90.7 kg) downward force on the arm. If the control arm moves, loosen the setscrew in the hub, reposition the arm in its highest setting and retorque the capscrew. Tighten the hub set screw and recheck the adjustment. Continue until the arm stays in position with 200 lb (90.7 kg) downward force applied to the arm.

7. Loosen the arm lock lever and check for free up and down control arm movement.

## INSTALL STEERING WHEEL

1. Position rear wheel so it points straight ahead.
2. Slide steering wheel onto shaft.
3. Coat inside of nut with Loc-tite 505-76, install nut and torque it to 10-15 ft-lb (95 N·m).
4. Mount cap over center of steering wheel. Align hole in cap with hole in steering wheel. Install screw to secure cap to the wheel.

## INSTALL SEAT

**Note:** For an additional 2-1/2 in. (64 mm) forward adjustment, mount the seat slides in the front set of mounting holes. For an additional 2-1/2 in. (64 mm) rearward adjustment, mount the slides in the rear mounting holes.

1. Support seat base in up position with the seat support rod.
2. Remove locknuts securing seat slides to plywood shipping base. Discard locknuts.
3. Secure seat and seat slides to seat support with 5/16-18 locknuts supplied in loose parts (Fig. 5).

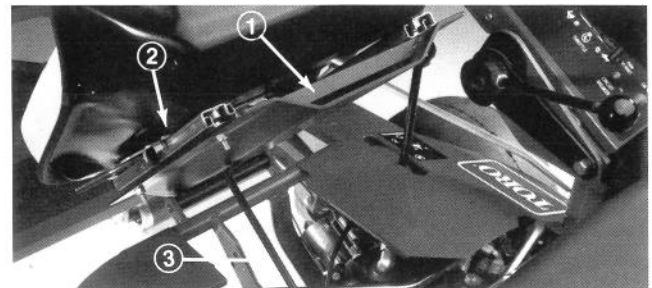

Figure 5

1. Seat support 2. Seat slide 3. Seat support rod

## INSTALL CUTTING UNITS

1. Remove cutting units from cartons. Assemble and adjust per the Operator's Manual for the cutting unit. Use the Height Gauge bar from Loose Parts Kit to adjust height of cut.
2. Slide the cutting units under the pull frames and position the hoop on the top of cutting units over the lift arms (Fig. 6).

# SET-UP INSTRUCTIONS

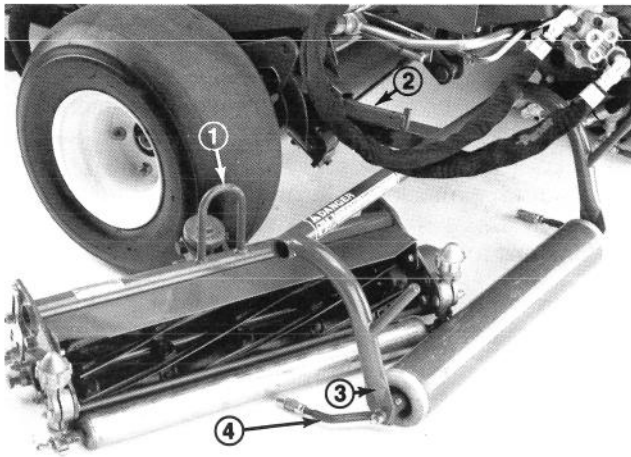

Figure 6

- 1. Hoop
- 2. Lift arm
- 3. Pull frame
- 4. Pull arm

3. Assemble the mount nuts for the reel drive motor to each cutting unit. Leave approximately 1/2 in. (13 mm) of threads exposed on each mount stud (Fig. 7).

4. Remove the protective covers from the cutting units and the reel drive motor shafts. Coat the spline shaft of the motor with clean grease and install the motor by rotating the motor clockwise so the motor flanges clear the studs. Rotate the motor counter-clockwise until the flanges are encircling the studs and tighten the mounting nuts (Fig. 7).

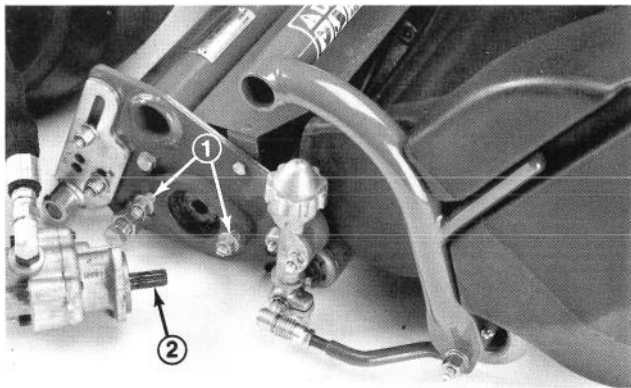

Figure 7

- 1. Motor mount nuts
- 2. Coat with grease

**Note:** Retain the protective covers for the cutting units. Install them whenever the reel drive motors are removed to protect the cutting unit bearings from contamination.

5. Slide the sleeve back on the ball joint and rotate the pull arm down so the socket fits over the ball stud. Release the sleeve so it slides over the stud and locks the assemblies together (Fig. 10).

6. Mount the baskets on the pull frames, loosen the jam nuts on the pull arms and adjust the ball sockets until there is 1/4 in. to 1/2 in. (6 to 12.7 mm)

clearance between the lip of the basket and the reel blades (Fig. 8).

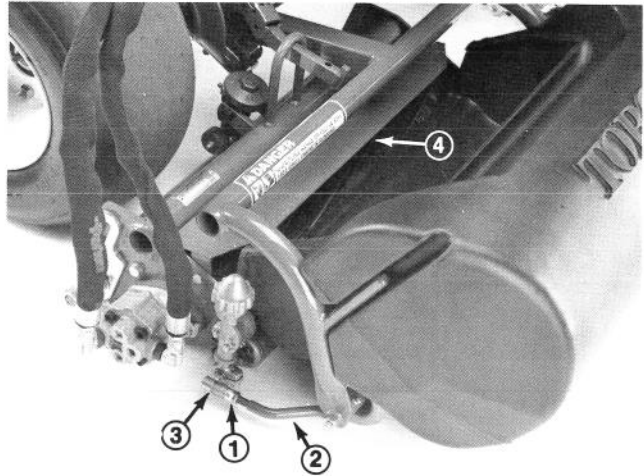

Figure 8

- 1. Jam nut
- 2. Pull arm
- 3. Ball joint — adjust for clearance
- 4. 1/4 - 1/2 in. (6 - 12.7 mm) clearance

**Note:** This prevents the basket from tipping the cutting unit forward causing the hoop to come off the lift arm while in the mowing operation.

Be sure the basket lips are equi-distant from the reel blades all across each reel. If the basket is too close to the reel, it is possible for the reel to contact the basket at the instant the cutting unit is raised off the ground.

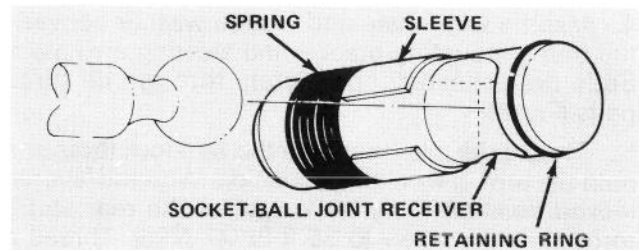

Figure 9

7. Align the sockets in the ball joints so the open side of the socket is centered towards the ball stud (Fig. 9). Tighten the jam nuts to secure the sockets in position (Fig. 8).

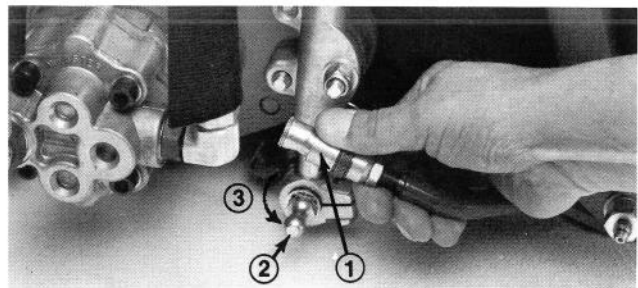

Figure 10

- 1. Slide back to mount
- 2. Ball stud
- 3. Swing down

# BEFORE OPERATING

## ADD ENGINE OIL

1. Move the machine to a level surface, stop engine and set parking brake. Unlatch and open the hood (Fig. 12).

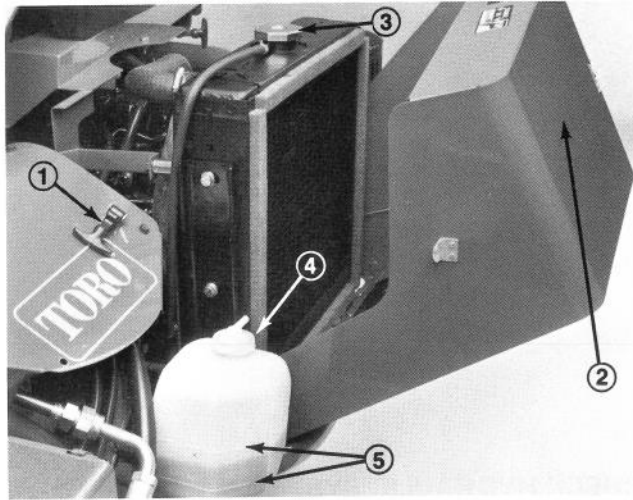

Figure 11

1. Engine hood latch
2. Engine hood
3. Radiator cap
4. Expansion tank cap
5. Fill marks

2. Remove dipstick from the left front of the engine, wipe end with a clean rag and insert it fully into the dipstick tube (Fig. 11). Remove dipstick and check oil level. If oil level is low, proceed to step 3. If oil level is up to the FULL mark on the dipstick, insert the dipstick and close and latch the hood. Continue with pre-operating procedures.

3. If oil level is low, unscrew the oil fill cap from the top of the engine (Fig. 11). Add a small quantity of a high-quality SAE 30 or 10W-30 detergent oil having the American Petroleum Institute — API — “service classification” CD and recheck the dipstick level. Continue until the oil level is up to the FULL mark on the dipstick. Do not overfill.

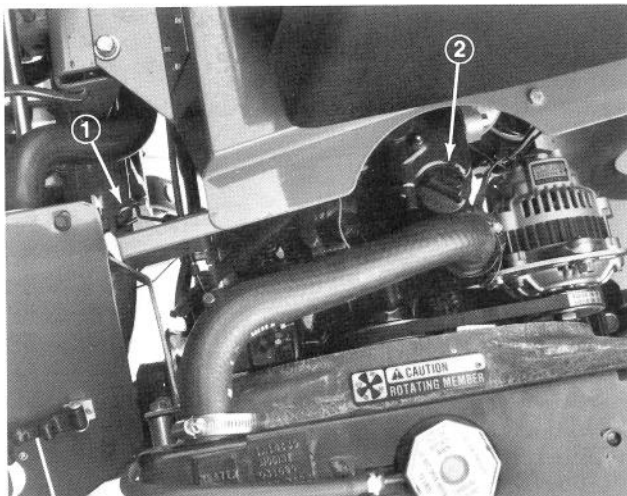

Figure 12

1. Oil dipstick
2. Oil fill hole

**IMPORTANT:** Check the oil level every 5 operating hours or daily. Change oil after every 50 hours operation and filter after every 100 hours.

4. Install and tighten oil fill cap and insert dipstick into tube. Close and latch the engine hood.

## CHECK COOLING SYSTEM

The cooling system is filled with a 50/50 solution of water and permanent ethylene glycol anti-freeze. Check level daily before starting the engine. Capacity of the system is approximately 4-1/2 qt (4.2 l).

1. Move the machine to a level surface, stop engine and set parking brake. Unlatch and open the engine hood (Fig. 12).

2. Carefully remove radiator cap and expansion tank cap (Fig. 12).



### CAUTION

If engine has been running, pressurized hot coolant can escape and cause burns when radiator cap is removed.

3. Inspect coolant level. The radiator coolant level should be to 1 inch (25 mm) below the filler neck and the expansion tank level midway between the minimum and maximum marks on its side (Fig. 12).

4. If coolant level is low, replenish the system. DO NOT OVERFILL.

5. Install radiator and expansion tank caps. Close and latch the engine hood.

## FILL FUEL TANK WITH DIESEL FUEL

The engine runs on No. 2-D or 1-D automotive type diesel fuel with a minimum cetane rating of 40.

**Note:** Higher cetane rated fuel may be required if machine is to be used at high altitudes and low-atmospheric temperatures.

Use No. 2-D diesel fuel at temperatures above 20°F (-7°C) and No. 1-D diesel fuel below 20°F (-7°C). Use of No. 1-D diesel fuel at lower temperatures provides lower flash point and pour point characteristics, therefore easing startability and lessening chances of chemical separation of the fuel due to low temperatures (wax appearance, which may plug filters).

Use of No. 2-D diesel fuel above 20°F (-7°C) will contribute toward longer life of the pump com-

# BEFORE OPERATING

ponents. Do not use furnace oil. Furnace oils usually contain heavy cracked distillates which are not suitable for diesel engines.

Store fuel outside of buildings in a convenient location. Tipping the front of the tank up slightly will allow contaminants to collect at the lower end away from the outlet. Never empty the tank below 4 in. (10 cm) from the bottom of the tank to avoid picking up water and other contaminants that may have collected at the bottom. Either filter the remainder at the bottom through a chamois or dispose of it periodically to prevent excessive build-up of contaminants.

Keep all fuel containers free of dirt, water, scale and other contaminants. Many engine difficulties can be traced to contaminants in the fuel.

Use only metal containers for fuel storage. DO NOT store the fuel in a galvanized metal container. A chemical reaction will result, which will plug the filters and cause possible fuel system damage.

If possible, fill the fuel tank at the end of each day. This will prevent possible buildup of condensation inside the fuel tank, preventing possible engine damage. Allow the engine to thoroughly cool down before refueling.

1. Using a clean rag, clean area around fuel tank cap.



**DANGER**

Because diesel fuel is flammable, caution must be used when storing or handling it. Do not fill fuel tank while engine is running, hot or when machine is in an enclosed area. Vapors may build up and be ignited by a spark or flame source many feet away. DO NOT SMOKE while filling the fuel tank to prevent the possibility of an explosion. Always fill fuel tank outside and wipe up any spilled diesel fuel before starting engine. Use a funnel or spout to prevent spilling diesel fuel and fill tank to about 1 inch (25 mm) below the filler neck. Store diesel fuel in a clean safety-approved container and keep the cap in place on the container. Keep diesel fuel in a cool, well-ventilated place; never in an enclosed area such as a hot storage shed. To assure volatility and to prevent contamination, do not buy more than a 6 month supply.

the top with diesel fuel. Install fuel tank cap tightly after filling tank.

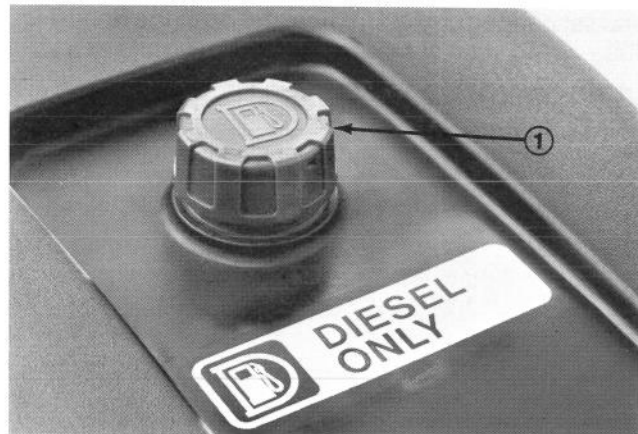

Figure 13

1. Fuel tank cap

## CHECK HYDRAULIC SYSTEM

The hydraulic system is designed to operate on Mobil DTE 26 or equivalent anti-wear hydraulic fluid. The machine's reservoir is filled at the factory with fluid. However, check level of hydraulic fluid before engine is first started and daily thereafter.

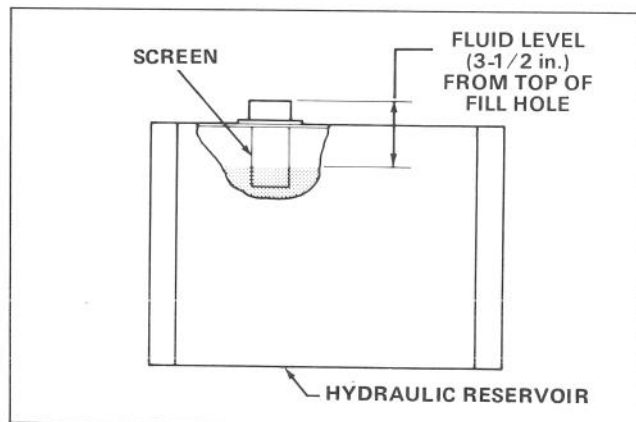

Figure 14

### Hydraulic Oil (Recommended brands):

Mobile	DTE 26
Shell	Tellus 68
Amoco	Rykon Oil #68
Conoco	Super Hydraulic Oil 68
Exxon	Nuto 68
Kendall	Kenoil R&O AW 68
Pennzoil	Penreco 68
Phillips	Magnus A 68
Standard	Energol HLP 68
Sun	Sunvis 831 WR
Union	Unax AW 68
Chevron	AW Hydraulic Oil 68

**Note:** All are interchangeable. Mobile SAE 10W30 or 10W40 may be substituted if the above oils are not available.

2. Remove cap from the fuel tank (Fig. 13) and fill the 7.5 gallon (28.4 l) tank to within 1 inch (25 mm) from

# BEFORE OPERATING

**IMPORTANT:** Use only hydraulic oils specified. Other fluids could cause system damage.

**Note:** A red dye additive for the hydraulic system oil is available in 2/3 oz. bottles. One bottle is sufficient for 4-6 gal. of hydraulic oil. Order Part No. 44-2500 from your Authorized Toro Distributor.

1. Park machine on a level surface. Make sure machine has cooled down so oil is cold.
2. Remove the cap from the top of the reservoir and check the fluid level. The fluid should be approximately 3-1/2 in. below the top of the fill hole.
3. If oil level is low, slowly fill with Mobile DTE 26 or equivalent hydraulic oil until level is up to correct level. Do not mix oils. Install cap.

**IMPORTANT:** To prevent system contamination, clean top of hydraulic oil containers before puncturing.

ing. Assure pour spout and funnel are clean.

## TIRE PRESSURE

The tires are over-inflated at the factory for shipping purposes. Reduce the pressure to the proper levels before starting the unit.

Vary the tire pressure for the drive wheels, depending upon your turf conditions, from a minimum of 8 P.S.I. (55.2 kPa) to a maximum of 12 P.S.I. (82.7 kPa). Vary the tire pressure for the rear wheel from a minimum of 8 P.S.I. (55.2 kPa) to a maximum of 15 P.S.I. (103.4 kPa).

Traction on the Greensmaster 3000-D can be improved with lower tire pressure.

# CONTROLS

## MOW PEDAL (Fig. 15)

Depressing Mow Pedal FULLY during operation lowers the cutting units and starts the reels. Due to detent action of the valve bank, the operator need not hold the pedal down during operation.

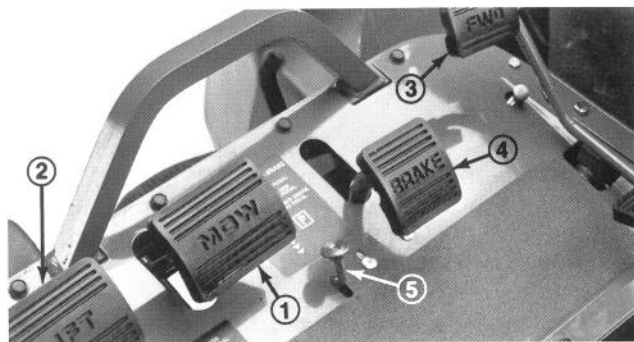

Figure 15

- |               |                   |                         |
|---------------|-------------------|-------------------------|
| 1. Mow pedal  | 3. Traction pedal | 5. Parking brake button |
| 2. Lift pedal | 4. Brake pedal    |                         |

## LIFT PEDAL (Fig. 15)

Depressing the Lift Pedal during operation stops the reels from rotating and lifts the cutting units. Lift pedal must be FULLY depressed until cutting units are fully raised and have ceased rotation.

## TRACTION PEDAL (Fig. 15)

Traction pedal has two functions; to make the machine move forward and, also to make it move in reverse. To move forward, depress the top of the pedal; for reverse, depress the bottom of the pedal. For operator comfort, do not rest heel on reverse portion of pedal during forward operation (Fig. 15, 16).

## BRAKE PEDAL (Fig. 15)

The Brake Pedal actuates an automotive mechanical drum-type brake located at each traction wheel.

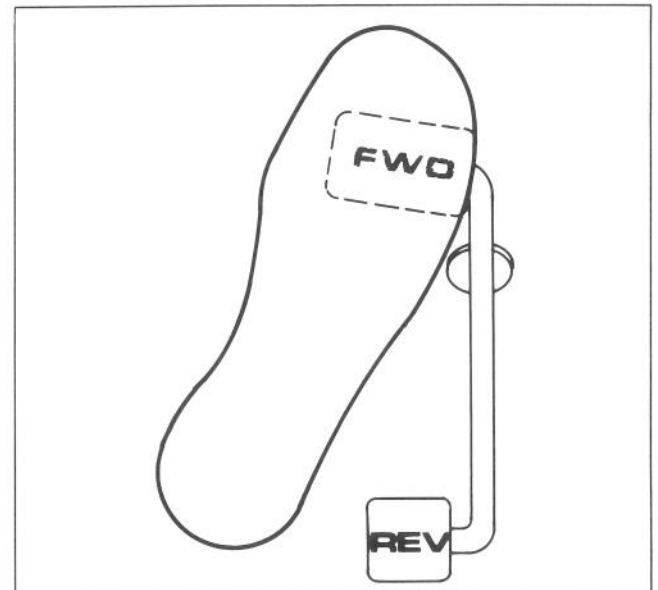

Figure 16

## PARKING BRAKE BUTTON (Fig. 15)

To lock the brakes for parking, depress the Brake Pedal, then depress the parking brake button. To disengage the parking brake, depress the brake pedal. Form the habit of locking the parking brake before leaving the machine.

## IGNITION KEY SWITCH (Fig. 17)

The ignition switch, used to start and stop the engine, has three positions: OFF, ON and START. Rotate key clockwise to START position to engage starter motor. Release key when engine starts. The key will automatically move to the ON position. Rotate key counter-clockwise to OFF position to stop engine.

# CONTROLS

## GLOW PLUG INDICATOR LIGHT (Fig. 17)

When ignition key is turned to ON position, glow plug indicator light will turn on, indicating glow plugs are being heated. Refer to Starting/Stopping Engine for starting procedure. A self-resetting 40 amp circuit breaker is incorporated to protect glow plug.

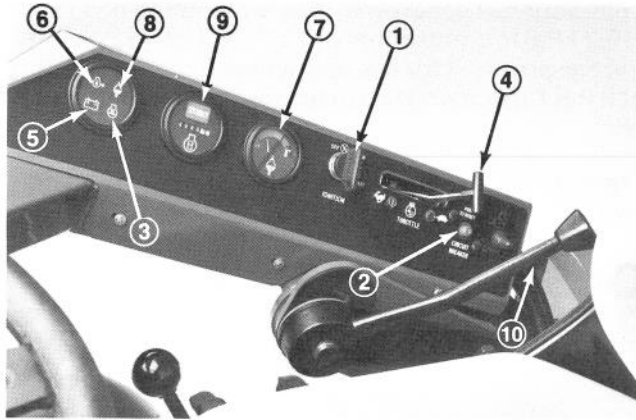

Figure 17

- |                                  |  |
|----------------------------------|--|
| 1. Ignition key switch           | 7. Coolant temperature gauge                   |
| 2. 15 amp circuit breaker        | 8. High coolant temperature indicator          |
| 3. Glow plug indicator light     | 9. Hour meter                                  |
| 4. Throttle control              | 10. Steering control arm height selector lever |
| 5. Charge indicator              |  |
| 6. Engine oil pressure indicator |  |

**IMPORTANT: Do not use ether or other type starting fluids to start engine.**

## THROTTLE CONTROL (Fig. 17)

Throttle control allows operation of the engine at various speeds. Moving control forward increases engine speed — FAST; rearward decreases engine speed — SLOW.

**Note:** The engine cannot be stopped by use of the throttle control.

## BATTERY CHARGING INDICATOR (Fig. 17)

The charging indicator light should be off when the engine is running. If it is on, the charging system should be checked and, if necessary, repaired.

## ENGINE OIL PRESSURE INDICATOR (Fig. 17)

If engine oil drops below a safe level, the light glows. Stop engine and repair before continuing operation.

## COOLANT TEMPERATURE GAUGE & INDICATOR (Fig. 17)

The coolant temperature gauge registers system coolant temperature. If temperature gets extreme, the engine will automatically shut off and the high

temperature indicator will light. Should this occur, turn the ignition key to OFF, check the radiator for debris, fan belt condition and expansion tank for proper coolant level. When coolant temperature has lowered to a safe level, the high temperature shutoff will automatically reset.

## HOUR METER (Fig. 17)

The hour meter registers accumulated engine operating time.

## STEERING ARM HEIGHT SELECTOR LEVER (Fig. 17)

Rotate lever counter-clockwise to loosen adjustment; clockwise to tighten. Raise or lower the control arm to fit operator comfort.

## CIRCUIT BREAKER (Fig. 17)

A 15 Amp circuit breaker to protect the electrical system is located in the control panel. Should the circuit breaker actuate, locate and correct the cause for this occurrence. Then, push the reset button to re-activate the circuit.

## SHIFT SELECTOR (Fig. 18)

Located on the top of the right hand panel. Provides two (2) traction selections, plus a "NEUTRAL" position. It is permissible to shift from one selection to another while the Greensmaster 3000-D is in motion. No damage will result.

1. Neutral — Used for starting Greensmaster 3000-D engine.
2. No. 1 Position — Used for greens mowing operation.

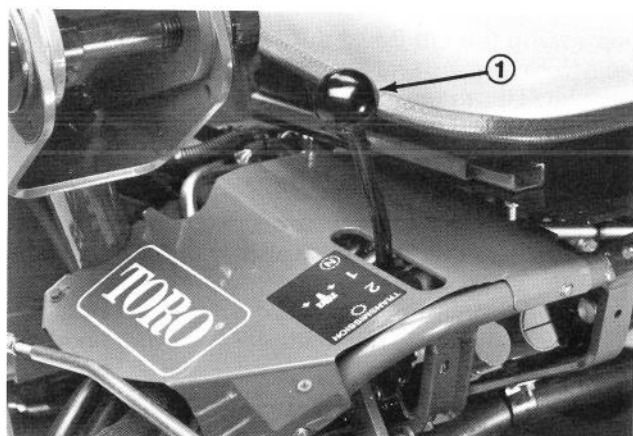

Figure 18

1. Shift selector

# CONTROLS

3. No. 2 Position — Used for transport operation.

**Note:** If Greensmaster 3000-D is operated in reverse with cutting units down the cutting units will be pulled off the lift arms.

## SEAT ADJUSTING HANDLE (Fig. 19)

Lever on left side of seat allows four inch (101 mm) fore and aft adjustment.

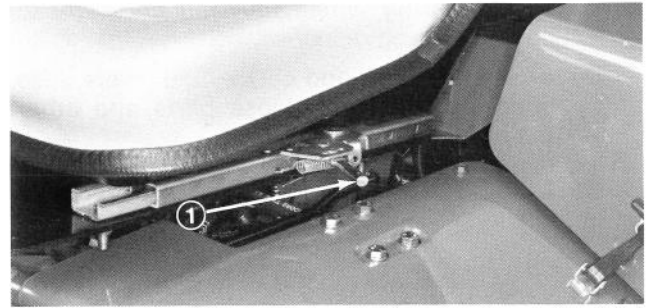

Figure 19

1. Seat adjusting handle (under seat)

## PRE-OPERATING INSTRUCTIONS

### BREAK-IN PERIOD

1. Refer to the Engine Manual supplied with the Greensmaster 3000-D for recommended oil change and maintenance procedures during engine break-in period.

2. Only 8 hours break-in period is required for components other than the engine on the Greensmaster 3000-D.

3. Since the first hours operation are critical to future machine dependability, monitor its functions and performance closely. Thus, minor difficulties can be noted and corrected before leading to major problems. Closely inspect the Greensmaster 3000-D during break-in for signs of oil leakage, loose fasteners or other malfunctions.

4. To assure optimum performance of the brake system, burnish (break-in) the brakes before use. To burnish brakes: Firmly apply brakes and drive machine at mowing speed until brakes are hot, as indicated by their smell. An adjustment to the brakes may be required after break-in, refer to Brake Adjustment, page 26.

### STARTING/STOPPING ENGINE

**IMPORTANT:** The fuel system must be bled if any of the following have occurred:

- A. Initial start-up of a new machine.
- B. Engine has ceased running due to lack of fuel.
- C. Maintenance has been performed upon fuel system components; i.e., filter replaced, separator serviced, etc.

Refer to Bleeding The Fuel System.

**Note:** Inspect areas beneath mowers to insure they are clear of debris. Clear area, if necessary, before starting.

1. Sit on seat, place shift selector in "Neutral", check mow and lift pedals to ensure they are level with one another.

2. Keep foot off traction pedal and make sure it is in neutral position.

3. Move throttle control to full FAST position.

4. Turn ignition key to "ON" position and hold until glow plug indicator light goes off (approximately 6 seconds).

**IMPORTANT:** Do not use ether or other type starting fluids to start engine.

5. Immediately turn ignition key to START position (Fig. 17). Release key immediately when engine starts and allow it to return to ON position. Move throttle control to SLOW position.

**Note:** Do not run starter motor more than 20 seconds at a time or premature starter failure may result. If engine fails to start after 20 seconds, turn key to OFF position. Recheck control settings and procedures, wait 10 additional seconds and repeat starter operation.

6. If engine fails to start, turn ignition key back to OFF, wait 2-3 seconds and repeat starting cycle.

7. Use the following procedures when the engine is first started, engine oil is changed, or engine, transmission or axle are overhauled.

A. Operate the machine in forward and reverse for one to two minutes.

B. Check operation of the mow and lift pedals.

# PRE-OPERATING INSTRUCTIONS

- C. Turn steering wheel fully left and right to check steering response.
- D. Shut engine off and check fluid levels. Also check for oil leaks, loose parts and other malfunctions.



## CAUTION

Shut engine off and wait for all moving parts to stop before checking for oil leaks, loose parts or other malfunctions.

- 8. To stop engine, move throttle to SLOW position and rotate ignition key to OFF. Remove key from switch to prevent accidental starting.

## BLEEDING FUEL SYSTEM

- 1. Locate fuel filter/water separator at right rear under fuel tank (Fig. 20).

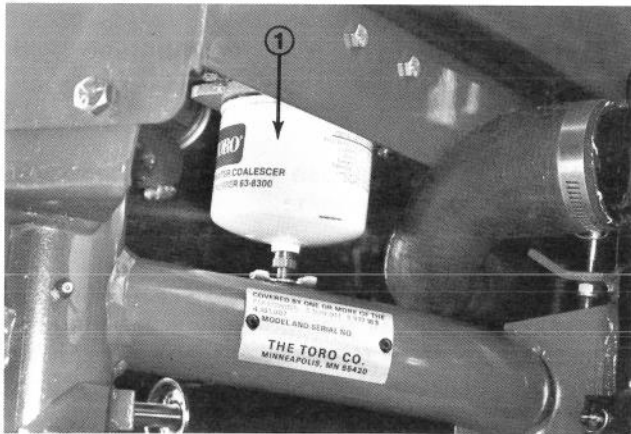

Figure 20

- 1. Fuel filter/water separator



## CAUTION

Be careful while working around muffler as it may be hot and cause injury.

- 2. From the left side of the rear wheel, locate air bleed screw on top of fuel filter/water separator and loosen the screw (Fig. 21).

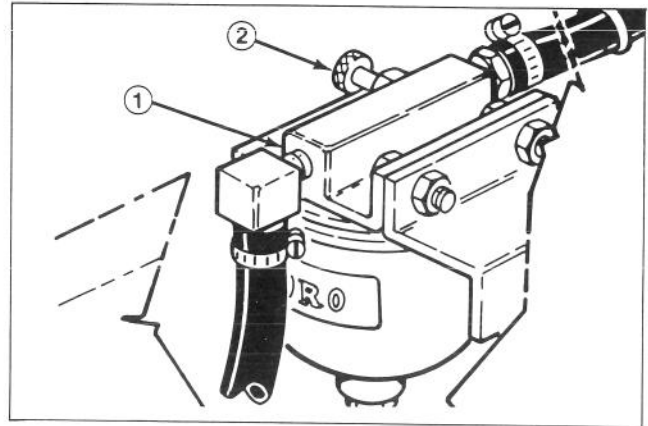

Figure 21

- 1. Fuel filter/water separator
- 2. Bleed screw

- 3. Rotate ignition switch key to RUN position. The electric fuel pump will begin operation forcing air out the air bleed screw. Leave key in RUN position until a solid stream of fuel flows out around screw. Tighten screw and rotate ignition key to OFF.

- 4. Unlatch and open engine hood.

- 5. Using a 10 mm wrench, open the air bleed screw on the fuel injection pump (Fig. 22).

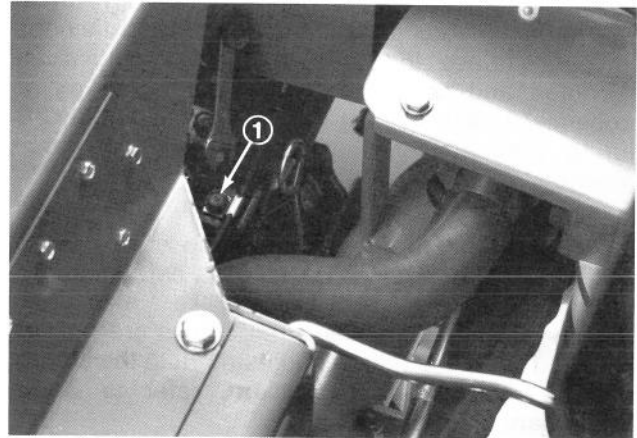

Figure 22

- 1. Fuel injection pump bleeder screw

- 6. Rotate ignition switch key to RUN position. The electric fuel pump will begin operation forcing air out the air bleed screw. Leave key in RUN position until a solid stream of fuel flows out around screw. Tighten screw and rotate ignition key to OFF.

- 7. Close and latch engine hood.

**Note:** Normally, engine should start after above bleeding procedures are completed. However, if engine does not start, air may be trapped between injection pump and injectors; refer to Bleeding Air From Injectors.

# PRE-OPERATING INSTRUCTIONS

## INITIAL PRE-OPERATING CHECK

**Note:** Inspect areas beneath mowers to insure they are clear of debris. Clear area, if necessary, before starting.

1. Sit on seat, place shift selector in "Neutral", check mow and lift pedals to ensure they are level with one another.
2. Keep foot off traction pedal, make sure it is in neutral position and move throttle control to full FAST position.
3. Start engine and allow it to thoroughly warm up. Then check the machine as follows:
  - A. With throttle control in FAST position, depress the mow pedal; cutting units should drop and all reels should turn.
  - B. Depress and hold the lift pedal down; cutting units should stop and raise to full transport position.

**Note:** Stop the engine and ensure the lip of each basket clears the reel during operation. If contact is noted, re-adjust the pull arms; refer to Installing Cutting Units, step 5, page 9.

- C. Depress the brake pedal to keep the Greensmaster 3000-D from moving. Operate the traction pedal through forward and reverse positions.
- D. Continue the procedures for 1-2 minutes, then neutralize the traction lever and mow and lift pedals. Lock the parking brake, stop the engine and remove the ignition key. Check for oil leaks. If leaks are evident, check hydraulic fittings for tightness. If oil leaks continue, contact your local TORO Distributor for assistance and, if necessary, replacement parts.

**IMPORTANT:** Motor or wheel seals may show some trace of oil for a brief period of time until the Greensmaster 3000-D break-in period has been completed.

**Note:** Since the Greensmaster 3000-D is new and the bearings and reels are tight, it is necessary to use the FAST throttle control position for this check. A fast throttle setting may not be required after the break-in period.

## CHECKING INTERLOCK SWITCHES

Perform the following three system checks daily to be sure the interlock system is operating correctly.

1. Sit on the seat. Engage the parking brake and fully depress lift pedal and release it. Move the shift selector to #1 and #2 positions while, at the same

time, trying to start the engine in each position. The engine should not crank, which means the traction switch on the valve bank is functioning correctly (Fig. 23). If engine did not crank, proceed to step 2. If engine cranked, there may be a malfunction in the safety interlock system.

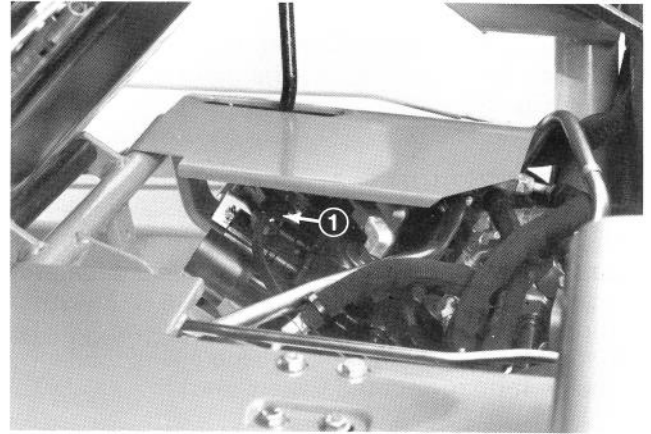

Figure 23

1. Traction switch

2. Sit on the seat. Engage the parking brake, fully depress the lift pedal and release it. Move the shift selector to neutral and try to start the engine. The engine should start and continue to run. This means the traction switch and mow/lift switch on the valve bank are functioning correctly. Proceed to step 3. If engine cranked, but did not start, there is a malfunction. It is not, however, in the interlock system.
3. Sit on the seat. Engage the parking brake and move the shift selector to neutral. Depress the mow pedal and try to start the engine. The engine should not crank. This means the mow/lift switch is functioning correctly. If the engine did not crank, proceed to step 4. If engine cranked, there is a malfunction in the safety interlock system.
4. Sit on the seat. Move the shift selector to neutral, depress the lift pedal and release it. Start engine and drive to an area free of debris and foreign objects. Keep all persons, especially children, away from machine and out of the area of operation. Move shift selector to Neutral and ensure mow pedal is disengaged. Set throttle control at half speed and engage parking brake. Hold steering wheel, brace feet on foot deck and brake pedal and move shift selector to #1 position. Carefully lift off seat: the engine should stop. If engine stops, the interlock system is functioning correctly.
5. Repeat the above check with shift selector in #2 position. If engine does not stop, stop the engine and find the problem before operating the machine again.

# PRE-OPERATING INSTRUCTIONS

## PREPARING MACHINE FOR MOWING

To assist in aligning the machine for successive cutting passes, it is suggested the following be done to the No. 2 and 3 cutting unit baskets:

1. Measure in approximately 5 inches (13 cm) from the outer edge of each basket.
2. Either place a strip of white tape or paint a line onto each basket paralleling the outer edge of each basket (Fig. 24).

## TRAINING PERIOD

Before mowing with the Greensmaster 3000-D, The Toro Company suggests you find a clear area and practice starting, stopping, raising and lowering cutting units, turning, etc. This training period will be beneficial to the operator in helping gain confidence in the performance of the Greensmaster 3000-D.

**IMPORTANT:** If you shift to the No.2 traction selector position while cutting greens, no increase in speed will result. However, a sudden increase in

speed will develop when you actuate the lift pedal. For safety purposes, it is recommended you use the No. 1 traction selection only for cutting greens and the No. 2 traction selection for transport.

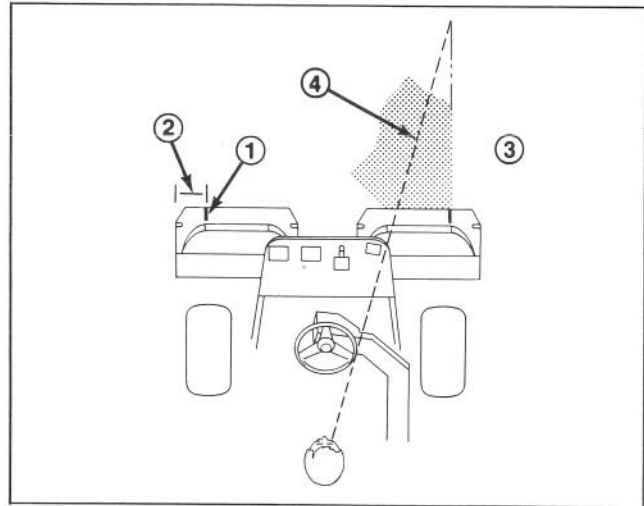

Figure 24

1. Alignment stripe
2. Approx. 5 in. (13 cm)
3. Cut grass on right
4. Keep focal spot 6-10 ft (1.8-3 m) ahead of machine

# OPERATING INSTRUCTIONS

## BEFORE MOWING

Inspect the green for debris, remove the flag from the cup, and determine the direction best to mow. Base the direction to mow on the previous mowing direction. Always mow in an alternate pattern from the previous mowing, so the grass blades will be less apt to lay down and therefore be difficult to trap between the reel blades and bed knife.

## MOWING PROCEDURES

1. Approach the green with the shift selector in the No. 1 position. Start on one edge of the green so the ribbon procedure of cutting may be used. This holds compaction to a minimum and leaves a neat, attractive pattern on the greens.
2. Actuate the mow pedal as the front edge of the grass baskets cross the outer edge of the green. This procedure drops the cutting units to the turf and starts the reels.

**Note:** The No. 1 (rear) cutting unit reel will not start until all the cutting units are on the ground and No. 2 and No. 3 cutting units are cutting.

**IMPORTANT:** Familiarize yourself with the fact that the No. 1 cutting unit reel is delayed and therefore, you should practice to try to gain the required timing necessary to minimize the cleanup mowing operation.

3. Overlap a minimal amount with the previous cut on return passes. To assist in maintaining a straight line across the green and keep the machine an equal distance from the edge of the previous cut, establish an imaginary sight line approximately 6 to 10 feet (1.8 to 3 m) ahead of the machine to the edge of the uncut portion of the green (Fig. 24, 25). Some find it useful to include the outer edge of the steering wheel as part of the sight line; i.e., keep the steering wheel edge aligned with a point that is always kept the same distance away from the front of the machine (Fig. 24, 25).

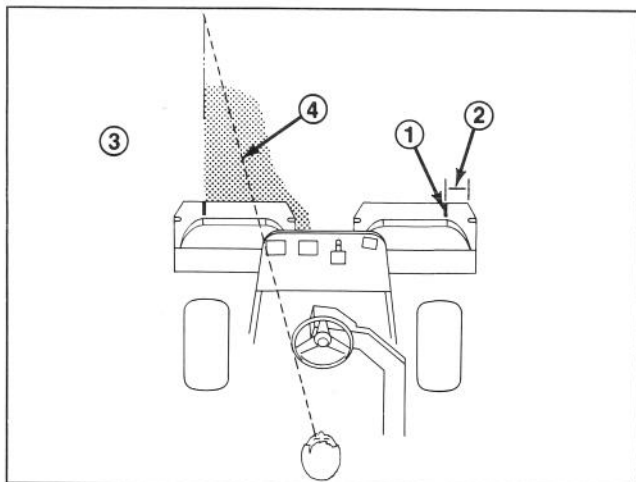

Figure 25

1. Alignment stripe
2. Approx. 5 in. (13 cm)
3. Cut grass on left
4. Keep focal spot 6-10 ft (1.8-3 m) ahead of machine

# OPERATING INSTRUCTIONS

4. As the front of the baskets cross the edge of the green, depress the lift pedal. This will stop the reels and lift the cutting units. Timing of this procedure is important so the mowers do not cut into the fringe area. However, as much of the green as possible should be cut to minimize the amount of grass left to mow around the outer periphery.

5. Cut down operating time and ease lineup for the next pass by momentarily turning the machine in opposite direction, then turning in the direction of the uncut portion; i.e., if intending to turn right, first swing slightly left, then right. This will assist in getting the machine more quickly aligned for the next pass. Follow the same procedure for turning in the opposite direction. It's good practice to try to make as short a turn as possible. However, turn in a wider arc during warmer weather to minimize the possibility of bruising the turf.

**Note:** Due to the nature of the power steering system, the steering wheel will not return to its original position after a turn has been completed.

**IMPORTANT:** The Greensmaster 3000-D should never be stopped on a green with the cutting unit reels operating as damage to the turf may result. Stopping on a wet green with the Greensmaster 3000-D may leave marks or indentations from the wheels.

6. Finish cutting the green by mowing the outer periphery. Be sure to change the direction of cutting from the previous mowing. Always keep weather and turf conditions in mind and be sure to change the direction of mowing from the previous cutting. Replace the flag.

7. Empty the grass baskets of all clippings before transporting to the next green. Heavy wet clippings place an undue strain on the baskets and add unnecessary weight to the machine, thereby increasing the load on the engine, hydraulic system, brakes, etc.

## TRANSPORT OPERATION

Make sure the cutting units are in the full up position. Set the shift selector in No. 2 if conditions will permit faster ground speed. Shift to No. 1 and operate at slower ground speeds in rough or hilly areas. Use the brakes to slow the machine while going down steep hills to avoid loss of control. Always approach rough areas at a reduced speed (shift selector in No. 1), and cross severe undulations carefully. Familiarize yourself with the width of the Greensmaster 3000-D. Do not attempt to pass between objects that are close together so that costly damage and downtime can be prevented.



### WARNING

The Greensmaster 3000-D should never be used as a tow vehicle. Gusset on rear frame may be used as a tiedown for transporting machine on a trailer or truck, but never as a hitch point. Loss of steering may occur causing possible injury.

## INSPECTION AND CLEAN-UP AFTER MOWING

At the completion of mowing operation, thoroughly wash the machine with a garden hose **without a nozzle** so excessive water pressure will not cause contamination and damage to seals and bearings. After cleaning, it is recommended the machine be inspected for possible hydraulic fluid leaks, damage or wear to hydraulic and mechanical components and the cutting units checked for sharpness. Also, lubricate the mow and lift pedal and brake shaft assembly with SAE 30 oil or spray lubricant to deter corrosion and help keep the machine performing satisfactorily during the next mowing operation.

## LUBRICATION



### CAUTION

Before servicing or making adjustments to the machine, stop engine and remove key from the switch.

The traction unit has grease fittings that must be lubricated regularly with No. 2 General purpose Lithium Base Grease. If machine is operated under normal conditions, lubricate all bearings and bushings after every 50 hours of operation.

1. Wipe grease fitting clean so foreign matter cannot be forced into the bearing or bushing.
2. Pump grease into the gearing or bushing.
3. Wipe up excess grease.

4. Apply grease to reel motor spline shaft when cutting unit is removed for service.

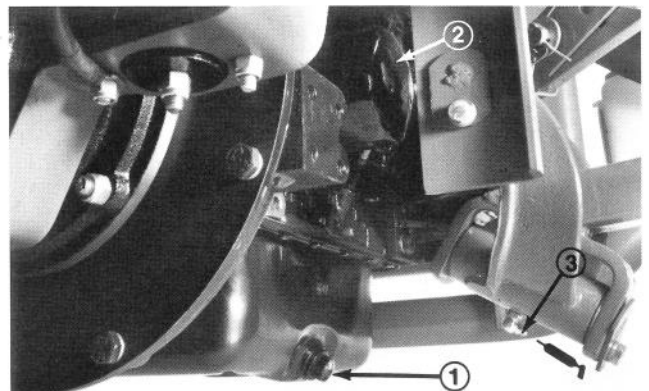
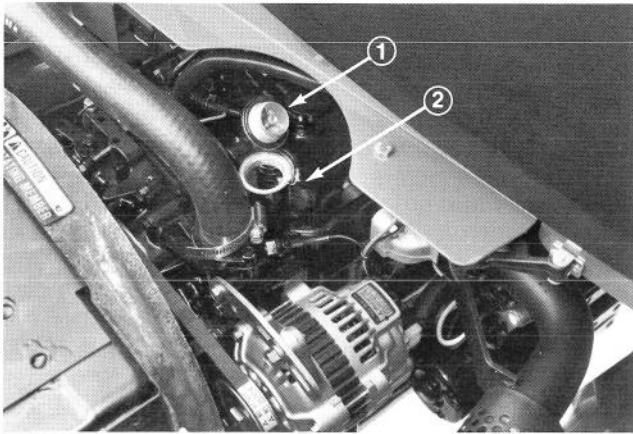

Figure 26

1. Engine oil drain plug    2. Engine oil filter    3. Pivot hinge

# LUBRICATION



**Figure 27**  
 1. Oil fill cap  
 2. Oil fill hole

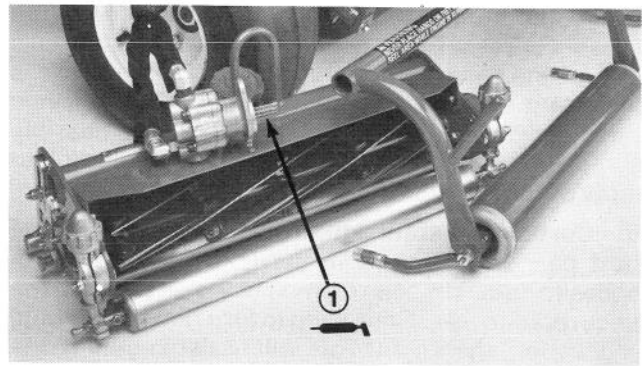

**Figure 30**  
 1. Coat with grease

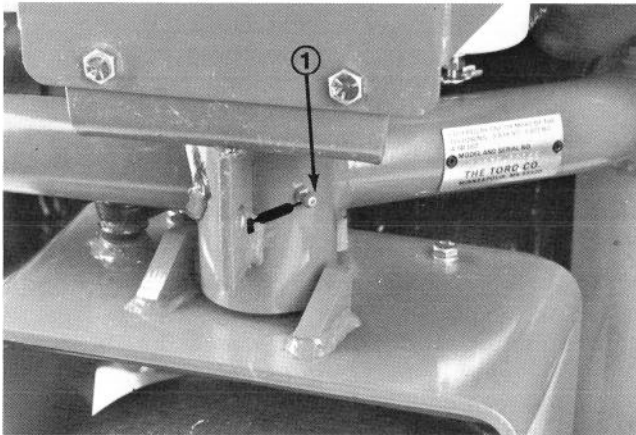

**Figure 28**  
 1. Grease

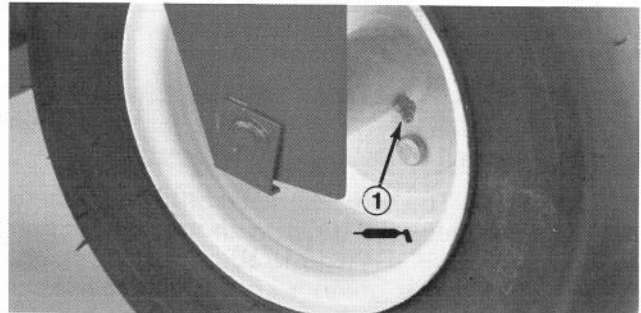

**Figure 31**  
 1. Rear wheel bearings

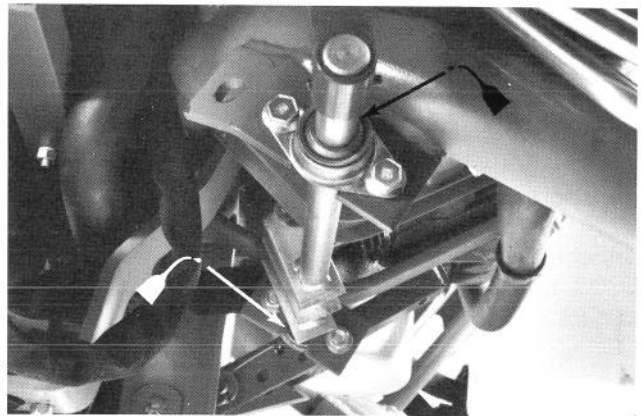

**Figure 32**



**Figure 29**  
 1. Mow pedal pivot  
 2. Lift arm pivot  
 3. Pull frame roller  
 4. Refer to cutting unit manual

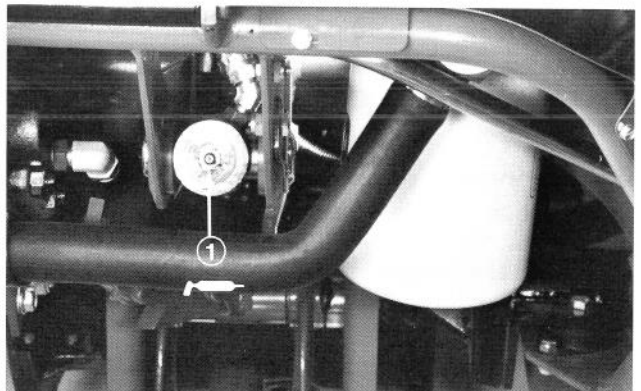

**Figure 33**  
 1. Cylinder mount pin

# SERVICE INTERVAL CHART

## GREENSMaster 3000 - D

### QUICK REFERENCE AID

**CHECK / SERVICE (daily)**

1. OIL LEVEL, ENGINE
2. OIL LEVEL, HYDRAULIC TANK
3. COOLING SYSTEM, ENGINE
4. BRAKE FUNCTION
5. INTERLOCK SYSTEM:
  - 5a. SEAT INTERLOCK
  - 5b. MOW - LIFT INTERLOCK
  - 5c. TRACTION INTERLOCK

**6. AIR CLEANER**

**7. TIRE PRESSURE**  
(8 - 12 psi front, 8 - 15 psi rear)

**8. WHEEL NUT TORQUE (40 - 50 FT-LBS.)**

**9. BATTERY**

**10. LUBRICATION**

**SEE OPERATOR'S MANUAL**

#### FLUID SPECIFICATIONS / CHANGE INTERVALS

See operator's manual for initial change	FLUID TYPES	CAPACITY	CHANGE INTERVALS		FILTER PART NO.
			FLUID	FILTER	
A. ENGINE OIL	SAE 30 SG	*4.3 QTS	50 HRS	100 HRS	67 - 4330
B. AIR CLEANER	---	---	---	100 HRS	27 - 7110
C. FUEL FILTER	---	---	---	400 HRS	63 - 8300
D. HYDRAULIC OIL	MOBIL DTE 26	4 1/2 GAL	2000 HRS	2000 HRS	74 - 3570
E. FUEL TANK	Diesel fuel No. 2-D or 1-D	7 1/2 GAL	---	---	---
F. RADIATOR	50:50 mix water/ethylene glycol	7 QTS.	EVERY 2 YRS	---	---

\* Including filter

92-1196

## MAINTENANCE

### GENERAL MAINTENANCE PRACTICES

To prevent possible severe engine damage and ensure maximum engine service life, periodically inspect the air cleaner and hose assembly.

1. Assure hose between air cleaner and engine is clamped securely in place. Replace the hose if it is cracked or punctured.
2. Check air cleaner body for dents and other damage which could possibly cause an air leak. Replace a damaged air cleaner body.
3. Insure dust cap is sealing around bottom of air cleaner body.
4. Mounting screws and nuts holding air cleaner in place must be tight.

5. Inlet cap must be free of obstructions.

### SERVICING DUST CUP AND BAFFLE

Inspect the dust cup and rubber baffle once a week or every 50 hours of operation; however, daily or more frequent inspection is required when operating conditions are extremely dusty and dirty. Never allow dust to build up closer than one inch (25 mm) from the rubber baffle.

**Note:** If conditions are extremely dusty and dirty, begin by checking dust cup and baffle after each day's operation to establish approximately how long an interval passes before dust cup should be emptied. Base further maintenance requirements on this figure.

# MAINTENANCE

1. Loosen thumb screw until dust cap and baffle can be removed (Fig. 34). Separate dust cap and baffle (Fig. 34).

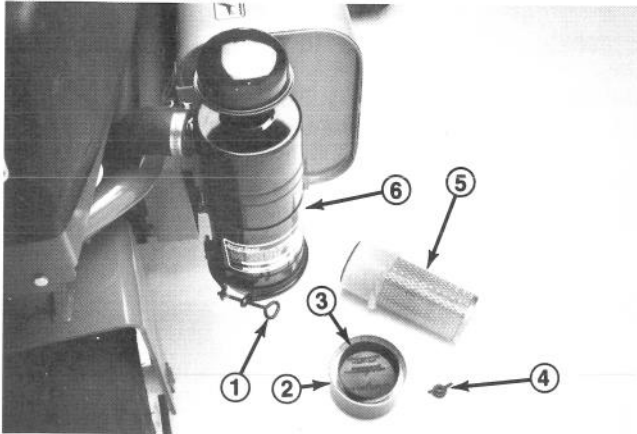

Figure 34

- |                |                         |
|----------------|-------------------------|
| 1. Thumb screw | 4. Wing nut with gasket |
| 2. Dust cap    | 5. Filter element       |
| 3. Baffle      | 6. Air cleaner body     |

2. Dump dust out of the dust cup. After cleaning cup and baffle, assemble and reinstall both parts.

## SERVICING AIR CLEANER FILTER

Service the air cleaner filter every 250 hours or more frequently in extreme dusty or dirty conditions by washing or using compressed air. Replace the element after every six cleanings (1500 hours) or annually, whichever comes first.

1. Remove and service dust cup; refer to Servicing Dust Cup and Baffle.
2. Remove wing nut w/gasket and slide filter element out of air cleaner body (Fig. 34).
3. Clean the element by washing it in a solution of filter cleaner (Part No. 27-7220, available from Toro) and water, or blow dirt out of filter by using compressed air.

**Note:** Compressed air is recommended when element must be used immediately after servicing because a washed element must be dried before it is used. By comparison, washing the element cleans better than blowing dirt out with compressed air. Remember though, filter must be washed when exhaust soot is lodged in the filter pores.

## Washing Method

**IMPORTANT: Do not remove plastic fin assembly because washing removes dust from beneath fins.**

- A. Prepare a solution of filter cleaner and water and soak filter element about 15 minutes. Refer to directions on filter cleaner carton for complete information.
- B. After soaking filter for 15 minutes, rinse it with clear water. Maximum water pressure must not exceed 40 psi (276 kPa) to prevent damage to the filter element.
- C. Dry filter element using warm, flowing air (160°F (71°C) max). or allow element to air-dry. Do not use compressed air or a light bulb to dry the filter element because damage could result.

## Compressed Air Method

**IMPORTANT: Do not remove plastic fin assembly because back-blowing with compressed air removes dust from beneath fins.**

- A. Blow compressed air from inside to the outside of dry filter element. Do not exceed 100 psi (689 kPa) to prevent damage to the element.
  - B. Keep air hose nozzle at least one inch (25 mm) from pleated paper, and move nozzle up and down while rotating the filter element. Inspect element when dust and dirt are removed; refer to Inspecting Filter Element.
4. Wipe inside of air cleaner body with a damp cloth to remove excess dust. Slide filter into air cleaner body and secure it in place with wing nut and gasket.
  5. Reinstall dust cup and baffle. Move thumb screw behind air cleaner body and tighten it securely.

## INSPECTING FILTER ELEMENT

1. Place bright light inside filter.
2. Rotate filter slowly while checking for cleanliness, ruptures, holes and tears. Replace defective filter element.
3. Check fin assembly, gasket and screen for damage. Replace filter if damage is evident.

# MAINTENANCE

## CLEANING RADIATOR AND SCREEN

To prevent the engine from overheating, the screen and front of the radiator must be kept clean. Normally, check the screen and front of radiator daily and, if necessary, clean any debris off these parts. However, it will be necessary to check and clean the screen and radiator frequently in extremely dusty and dirty conditions.

**Note:** If engine shuts off due to overheating, first check the radiator and screen for excessive buildup of debris.

To thoroughly clean the radiator and screen:

1. Unlatch and open the hood.
2. Working from inside the screen and the fan side of the radiator, either spray the screen and radiator with a water hose or blow with compressed air.
3. After the radiator and screen are thoroughly cleaned, cut out debris that may have collected at the base of the screen.
4. Close and latch the hood.

## CHANGING CRANKCASE OIL AND FILTER

Check oil level after each days operation or each time machine is used. Change oil after every 50 hours of operation and filter every 100 hours of operation. If possible, run engine just before changing oil because warm oil flows better and carries more contaminants than cold oil.

1. Position machine on a level surface, stop the engine and set parking brake.
2. Open the hood. Set drain pan under the oil pan and in line with drain plug (Fig. 35).

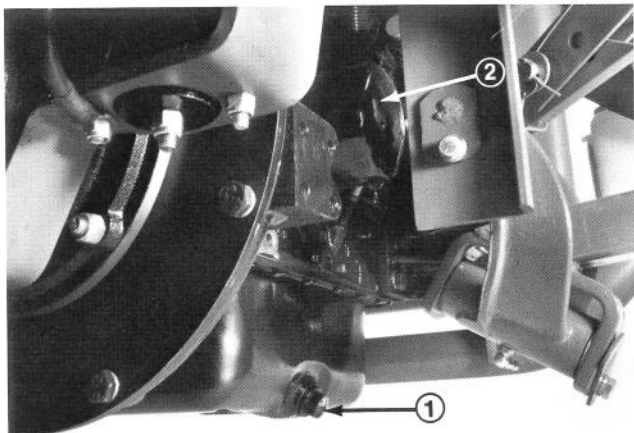

Figure 35

1. Oil drain plug
2. Engine oil filter

3. Clean area around drain plug.
4. Remove oil drain plug and allow oil to flow into drain pan. Remove and replace oil filter (Fig. 35); refer to parts catalog for part number.
5. After oil is drained, reinstall drain plug and wipe up any oil that is spilled.
6. Fill crankcase with oil; refer to Check Crankcase Oil.

## SERVICING FUEL SYSTEM

**Note:** Refer to Fill Fuel Tank With Diesel Fuel for proper fuel recommendations.

### Fuel Tank

Drain and clean fuel tank every 400 hours operation or yearly, whichever comes first. Also, drain and clean tank if fuel system becomes contaminated or if machine is to be stored for an extended period. Use clean diesel fuel to flush out the tank.

**Note:** A fuel shut-off valve is located on the underside of the fuel tank (Fig. 36).

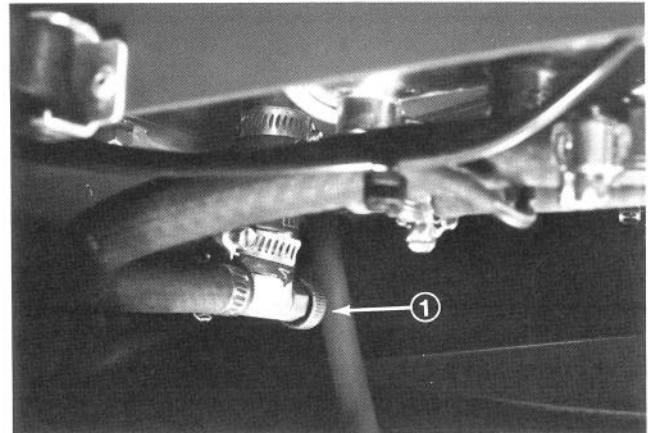

Figure 36

1. Fuel shut-off valve

### Fuel Lines and Connections

Check lines and connections every 400 hours or yearly, whichever comes first. Inspect for deterioration, damage or loose connections.

### Fuel/Filter/Water Separator

Drain water or other contaminants from fuel filter/water separator under fuel tank daily (Fig. 37) by loosening drain plug on filter canister. Tighten plug after draining. Replace filter canister after every 400 hours of operation; refer to Toro Parts Catalog for part number.

1. Clean area where filter canister mounts.

# MAINTENANCE

2. Remove filter canister and clean mounting surface.
3. Lubricate gasket on filter canister with 10W-30 oil.
4. Install filter canister by hand until gasket contacts mounting surface, then rotate an additional 1/2 turn.

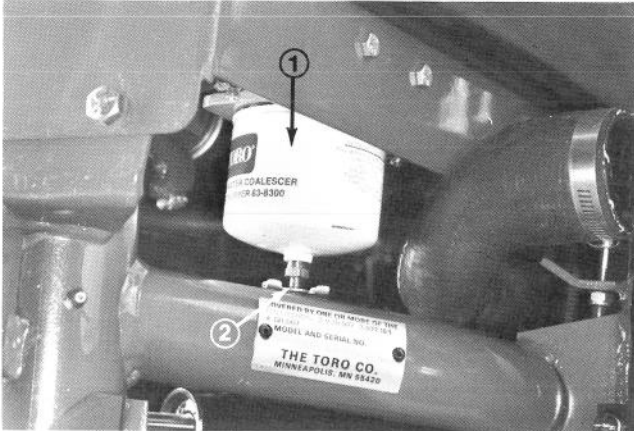

Figure 37

1. Fuel filter canister
2. Water drain



## CAUTION

Since diesel fuel is highly flammable, ensure the muffler and other exhaust components are thoroughly cooled down before removing the fuel pump cover.

### Fuel Pump Filter

Remove and replace the filter after every 400 hours operation.

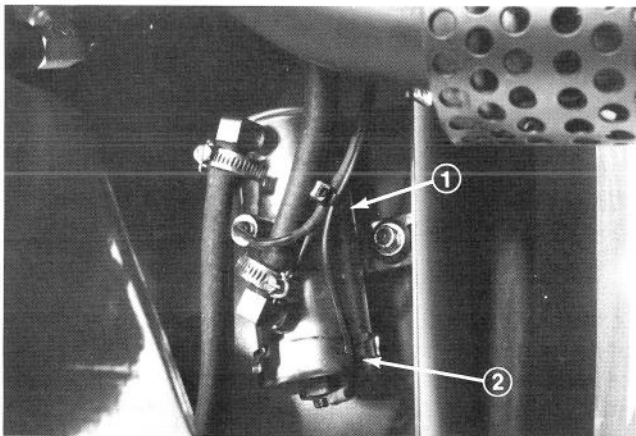

Figure 38

1. Fuel pump assembly
2. Fuel pump cover — unscrew

1. Fuel pump is located under the fuel tank (Fig. 38).
2. Thoroughly clean outside of assembly.
3. Place a drain pan under fuel pump and remove cover from fuel pump with 17 mm wrench (Fig. 38). Take care not to damage wire while removing cover.
4. Pull filter out of pump body.
5. If filter is to be cleaned, wash thoroughly in cleaning solvent and blow compressed air from inside toward outside of element. Hold air nozzle at least one inch (25 mm) from filter and move up and down while rotating filter. Do not exceed 100 psi (689 kPa) to avoid filter damage.

**Note:** Replace the filter if there is visible dirt which cannot be washed out.

6. Inspect the two rubber gaskets; replace them if damaged.
7. Clean magnet of any residue, insert filter into body and install cover.
8. Bleed the fuel system; refer to Bleeding Fuel System.

### BLEEDING AIR FROM INJECTORS

**Note:** This procedure should be used only if fuel system has been purged of air through normal priming procedures and engine still will not start; refer to Bleeding Fuel System.

1. Loosen the tube connection to the No. 1 nozzle and holder assembly (Fig. 39).

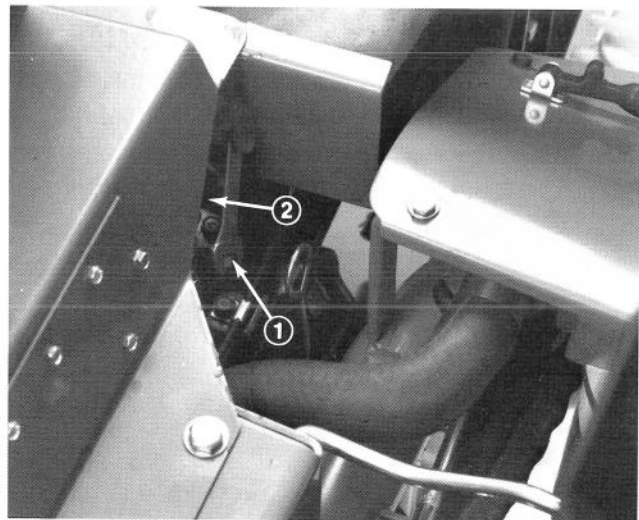

Figure 39

1. Pipe connection
2. Fuel injectors

2. Move throttle control to full FAST position.

# MAINTENANCE

3. Turn key in key switch to START position and watch fuel flow around connector. Turn key to OFF position when solid flow is observed.



## CAUTION

Do not attempt to start engine. Wear eye protection and keep hands away from connectors while performing this procedure.

4. Tighten tube connector securely.
5. Repeat steps 1-4 on No. 2 and 3 nozzles.

## SERVICING ENGINE BELTS

Check tension of all belts initially after the first day of operation and every 100 hours thereafter.

### Alternator and Cooling Fan Belt

To Check Tension:

1. Unlatch and open hood.
2. Check tension by depressing belt midway between alternator and crankshaft pulleys with 22 lb (10 Kg) of force (Fig. 40). Belt should deflect 7/16 in. (9 to 11 mm). If deflection is incorrect, proceed to step 3. If correct, continue operation.
3. Loosen bolt securing brace to engine and bolt at bottom of alternator securing alternator to engine (Fig. 40).

**Note:** Metric wrenches will be required.

4. Insert pry bar between alternator and engine and pry out on alternator.
5. Hold alternator in position after proper belt tension setting is achieved and tighten alternator and brace bolts to secure adjustment.
6. Close and latch hood.

To Replace Belt:

1. Unlatch and open hood.
2. Loosen bolts securing alternator to engine and alternator to brace (Fig. 40).

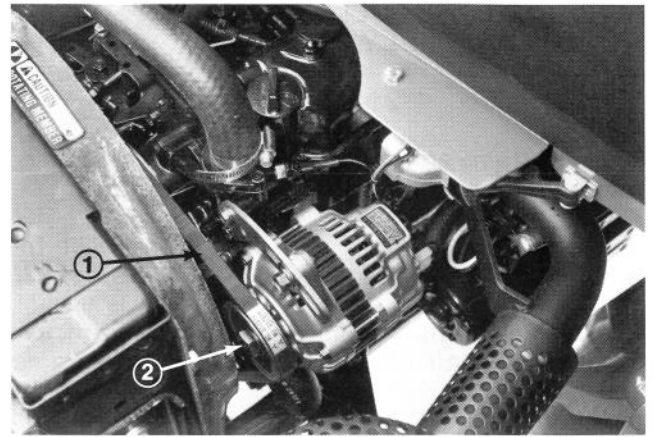

Figure 40

1. Alternator/water pump belt
2. Tension adjustment bolt

3. Remove old belt. Work the new belt between the fan and fan shroud. Fit the belt over the fan blades and install it over the fan, alternator and crankshaft pulleys.

4. Tension the new belt; refer to To Check Tension, page 25.

5. Close and latch the hood.

6. Recheck belt tension after one day's operation.

## CHANGING COOLANT IN COOLING SYSTEM

The cooling system must be filled with a 50/50 solution of water and permanent ethylene glycol antifreeze. After every two years, drain the coolant from the radiator, reservoir expansion tank and engine by opening the drain cock and block plug. After coolant is drained, flush the entire system and refill it with a 50/50 solution of water and anti-freeze. Capacity of cooling system is approximately 7 quarts (6.4 l). When filling, fill the radiator completely and fill the expansion tank to between the marks. **DO NOT OVERFILL.** Always install radiator cap securely.



## CAUTION

Cooling system is pressurized when hot. Allow system to cool before servicing the system.

# MAINTENANCE

## SERVICING THE PULL FRAME AND ROLLER ASSEMBLY

Tools Required: 1/2 in., 5/8 in. wrench.

The pull frame and roller assembly are disassembled by the following procedures:

1. Lower the cutting units and disconnect the pull rods from each end of the cutting unit.
2. Loosen mount nuts and remove reel drive motor. Insert motor shaft into support tube on front of frame and install the protective cap in the bearing housing of the cutting unit.
3. Roll the cutting unit forward off the lift arm and slide it out from beneath the pull frame.
4. Locate the capscrew at the base of the rear of the pull frame which secures the pull frame pivot pin and remove it.
5. Slide the pivot pin out of the frame and lift the yoke of the frame away from the traction unit.
6. Reassemble in reverse order of the disassembly procedures.

## BRAKE ADJUSTMENT

Tools Required: 1/2 in. wrench, pliers.

A brake adjustment rod is located on each side of the Greensmaster 3000-D so the brakes can be equally adjusted. (Fig. 41). Adjust the brakes as follows:

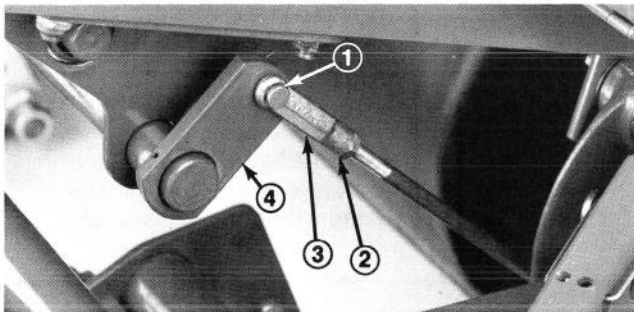

Figure 41

- |                              |                |
|------------------------------|----------------|
| 1. Clevis pin and cotter pin | 3. Clevis      |
| 2. Jam nut                   | 4. Brake shaft |

1. Transport the Greensmaster 3000-D and depress the brake pedal; both wheels should lock equally.



### CAUTION

As a safety precaution, always check brakes in a wide, open spaced, level area which is free of other persons and obstructions before and after adjustment.

2. If the brakes do not lock equally, disconnect the brake rods by removing cotter pin and clevis pin (Fig. 41).
3. Loosen jam nut and adjust clevis accordingly.
4. Assemble clevis to brake shaft.
5. Check the amount of free travel of the brake pedal when adjustment is completed. There should be 1/2 in. to 1 in. (12.7 to 25 mm) travel before the brake shoes make contact with the brake drums. Re-adjust, if necessary, to achieve this setting (Fig. 42).

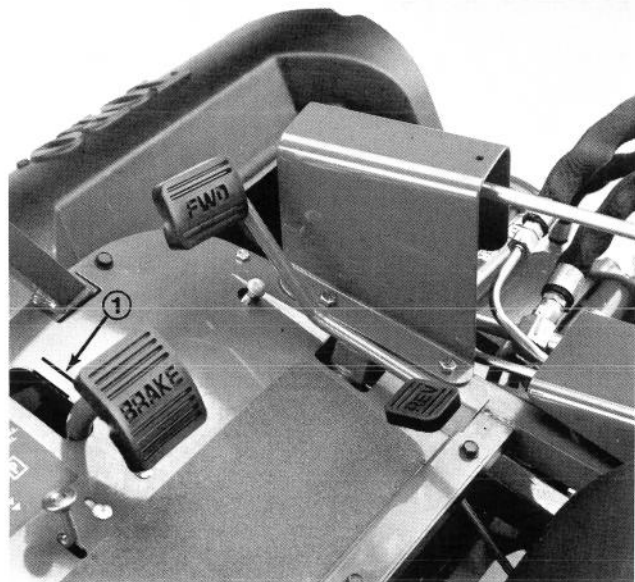

Figure 42

1. 1/2 - 1 in. (12.7 - 25 mm) travel

6. Transport the Greensmaster 3000-D and depress the brake pedal; both brakes should lock equally. Readjust, if necessary.
7. It is recommended that the brakes be burnished annually, refer to Break-In Period, page 15.

# MAINTENANCE

## SERVICING BATTERY

**IMPORTANT:** Before welding on the machine, disconnect ground cable from the battery to prevent damage to the electrical system.

**Note:** Check battery condition weekly or after every 50 hours of operation. Keep terminals and entire battery case clean because a dirty battery will slowly discharge. To clean the battery, wash the entire case with solution of baking soda and water. Rinse with clear water. Coat the battery posts and cable connectors with Grafo 112X (Skin-over) grease, Toro Part No. 505-47 or petroleum jelly to prevent corrosion.



### CAUTION

Since gases from the battery are explosive, keep open flame and electrical spark away from the area; do not smoke.

## ELECTRICAL SWITCH SERVICING

Tools Required: Volt-ohm meter or continuity tester, 15/16 in. wrench, quantity of GRAFO 112X(Skin-Over) grease, TORO part No. 505-47.

## GENERAL SWITCH MAINTENANCE

The following procedures should be followed whenever a switch requires adjustment or replacement:

1. Be sure rubber boot is re-installed in both switch grooves on the button end of seat switch after it is properly adjusted.

**IMPORTANT:** Rubber boot on button end must be in place to make sure all dirt, moisture and grease are kept from the plunger sides.

2. Spread GRAFO 112X(Skin-Over) grease (Toro Part No. 505-47) heavily over the terminal end and inside the terminal cover of all switches before installing the connectors and terminal cover. Be sure the wires are fully connected.

## SEAT SWITCH REMOVAL, INSTALLATION AND ADJUSTMENT

1. Pivot seat forward and secure it with support rod to prevent it from falling accidentally and possibly causing injury.

2. Remove boot from button end of seat switch and retain for installation on replacement switch. Pull connectors off switch terminals.

3. Loosen the jam nut and unscrew the switch from mounting bracket.

4. Screw new switch through mounting bracket until switch button is about 1/16 inch (1.6 mm) shorter than the top of the seat return spring pin. Install the boot into the mount grooves (Fig. 43).

5. Carefully release the seat to its normally down position, but do not sit or apply force on the seat. There should be a slight gap between the switch and the seat plate.

6. Make sure switch terminals face side of machine and lock switch in place by tightening the jam nut to 75 in.-lb (8.5 N-m) against the mounting bracket.

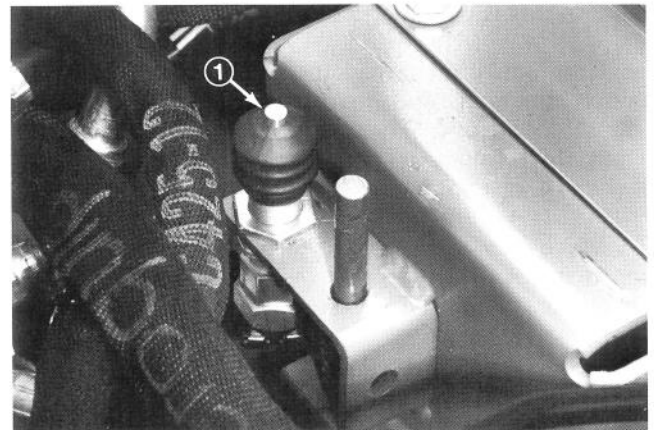

Figure 43

1. Seat switch

**IMPORTANT:** Switch threads will be damaged if the jam nut is over-tightened.

7. Connect continuity tester or ohm meter to switch terminals. With seat in the down position and no one on the seat, the switch circuit should not have continuity. If there is continuity, repeat steps 4-6. If there is no continuity, proceed to step 8.

8. Sit on the seat. The seat switch should have continuity. If there is no continuity, repeat steps 4-7. If there is continuity proceed to step 9.

9. Fill terminal end of switch and wiring harness cover with GRAFO 112X(Skin-Over) grease, TORO part number 505-47 and push connectors onto switch terminals. Be sure connectors are fully connected.

# MAINTENANCE

## TRACTION SWITCH REMOVAL, INSTALLATION AND ADJUSTMENT

1. Pull connector off switch terminals of traction switch installed in valve bank bonnet on selector valve section.
2. Loosen the jam nut and unscrew the switch from the mounting bracket.
3. Move shift selector to Neutral.
4. Partially screw new switch into bonnet.
5. Connect a continuity tester or ohm meter to the switch terminals and continue to turn the switch in until there is continuity. Then rotate switch in 1/2 turn (180°).
6. Secure jam nut to 75 in.-lb (8.5 N·m) against the bonnet.

**IMPORTANT: Switch threads will be damaged if the jam nut is over-tightened.**

7. Connect continuity tester or ohm meter to switch terminals and move shift selector to the #1 and #2 positions. There should not be continuity when shift selector is in either of these positions. If there is continuity, repeat steps 4 and 5.
8. Move the shift selector lever to Neutral and connect continuity tester or ohm meter to switch terminals. The switch should show continuity. This means the switch is operating correctly.
9. Fill terminal end of switch and wiring harness cover with GRAFO 112X (Skin-Over) grease TORO Part No. 505-47 and push connectors onto switch terminals.

## MOW/LIFT SWITCH REMOVAL, INSTALLATION AND ADJUSTMENT

**IMPORTANT: Spool travel for 1, 2 and 3 spools must be correct before Mow/Lift switch can be**

**adjusted. Refer to Rear Camshaft Adjustment, page 33.**

1. Pull connector off switch terminals from end of mow/lift switch installed in the valve bank bonnet.
2. Loosen jam nut and unscrew switch from valve bank bonnet.
3. While holding lift pedal in fully depressed position (valve bank spools fully IN) partially screw new switch into bonnet.
4. Connect continuity tester or ohm meter across switch terminals and turn switch in until continuity occurs. Then rotate switch in 1/2 turn (180°) and secure jam nut to 75 in.-lb. (8.5 N·m) against the bonnet.

**IMPORTANT: Switch threads will be damaged if the jam nut is over-tightened.**

5. Connect continuity tester or ohm meter to switch terminals and depress the mow pedal. There should not be continuity. If there is continuity, repeat step 3. Proceed to step 6 if there is no continuity.
6. Depress the lift pedal and release it (neutral position). The switch circuit should have continuity.
7. Fill terminal end of switch and wiring harness cover with GRAFO 112X(Skin-Over) grease, TORO Part No. 505-47, and push connectors onto switch terminals.

## WIRING HARNESS SERVICE

Prevent corrosion of wiring terminals by applying Grafo 112X (Skin-over) grease, Toro Part No. 505-47, to the inside of all harness connectors whenever the harness is replaced.

Whenever working with the electrical system, always disconnect battery cables, negative (—) cable first, to prevent possible wiring damage from short-outs.

# ELECTRICAL SCHEMATIC

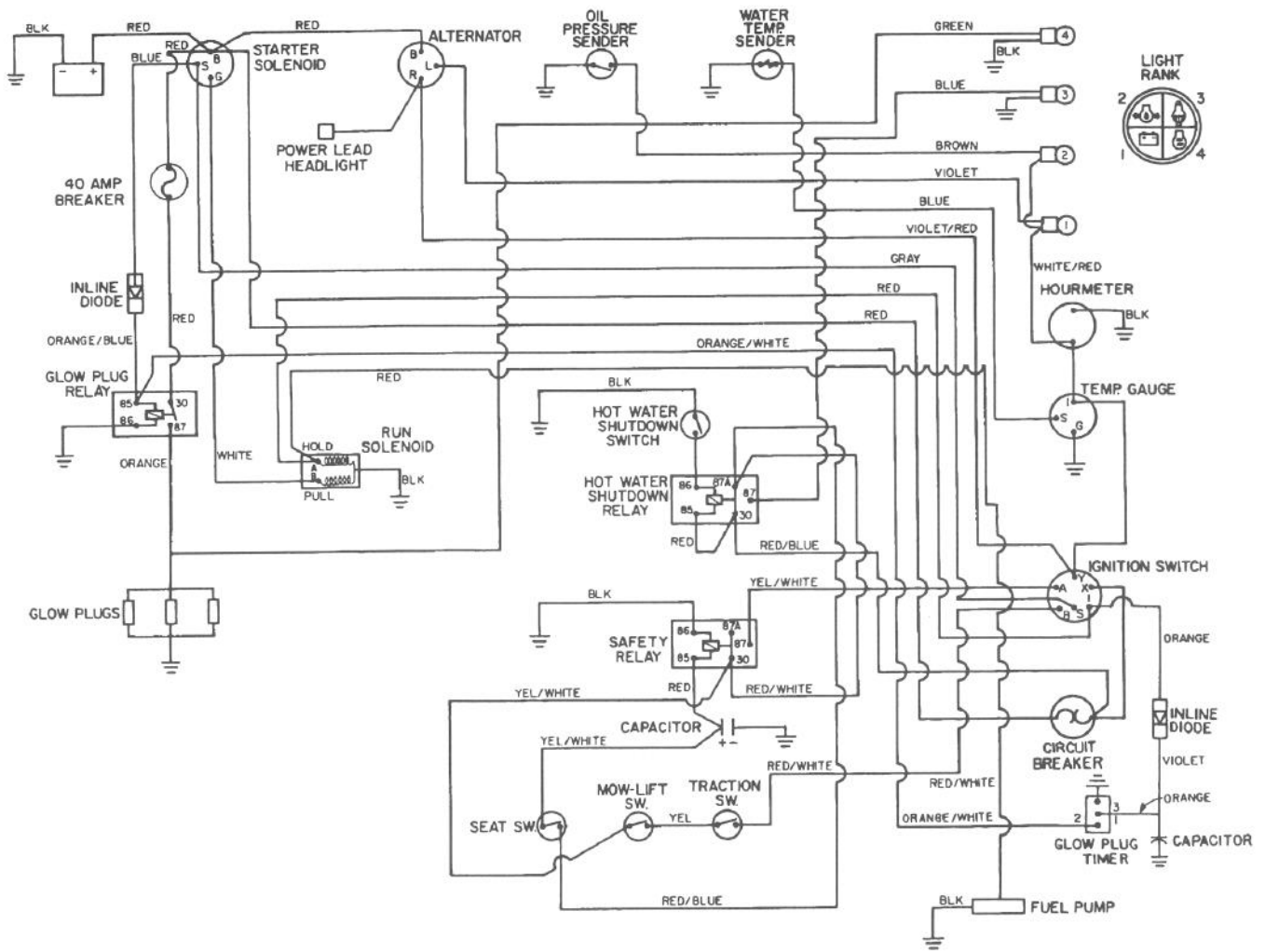

## MAINTENANCE TROUBLE SHOOTING

CONDITION	CAUSE	CORRECTION
1. Engine starts (but should not) when shift selector is in gear.	<ul style="list-style-type: none"> <li>• Traction switch adjusted incorrectly or is malfunctioning.</li> </ul>	<ul style="list-style-type: none"> <li>• Refer to Installing and Adjusting Traction Switch, page 28.</li> </ul>
2. Engine starts (but should not) when mow pedal is depressed (reels engaged).	<ul style="list-style-type: none"> <li>• Mow/lift switch adjusted incorrectly or is malfunctioning.</li> </ul>	<ul style="list-style-type: none"> <li>• Refer to Installing and Adjusting Mow/Lift Switch, page 28.</li> </ul>
3. Engine fails to crank, regardless of shift selector or mow pedal position.	<ul style="list-style-type: none"> <li>• Mow/lift switch and/or Traction switch adjusted incorrectly or are malfunctioning.</li> <li>• Battery terminals corroded.</li> <li>• Mow/lift or traction switch wires are loose.</li> </ul>	<ul style="list-style-type: none"> <li>• Refer to Installing and Adjusting Traction Switch, page 28.</li> <li>• Refer to Installing and Adjusting Mow/Lift Switch, page 28.</li> <li>• Clean terminals.</li> <li>• Check wires and connect them properly.</li> </ul>

# MAINTENANCE – TROUBLE SHOOTING

CONDITION	CAUSE	CORRECTION
3. Engine fails to crank, regardless of shift selector or mow pedal position (continued).	<ul style="list-style-type: none"> <li>● Battery is dead.</li> <li>● Starter solenoid is malfunctioning.</li> <li>● Ignition switch is malfunctioning.</li> <li>● Starter is malfunctioning.</li> <li>● Engine is seized.</li> <li>● Key Switch or solenoid wires loose.</li> </ul>	<ul style="list-style-type: none"> <li>● Charge or replace battery.</li> <li>● Replace solenoid.</li> <li>● Replace ignition switch.</li> <li>● Replace or repair starter.</li> <li>● Repair engine.</li> <li>● Connect wires.</li> </ul>
4. Engine fails to crank with controls in "Neutral" when operator is off seat, but does crank when operator is on seat.	<ul style="list-style-type: none"> <li>● Wiring harness connected wrong.</li> <li>● Wiring harness malfunctioning.</li> </ul>	<ul style="list-style-type: none"> <li>● Connect harness correctly: refer to Electrical Schematic, page 29.</li> <li>● Install new wiring harness.</li> </ul>
5. Engine cranks but does not start when shift selector and mow pedal are in neutral.	<ul style="list-style-type: none"> <li>● The cause of this problem is <u>unrelated</u> to interlock wiring system.</li> <li>● Rear camshaft maladjusted.</li> <li>● Fuel pump malfunctioning.</li> <li>● Blocked fuel system.</li> <li>● "I" terminal wire of key switch loose.</li> <li>● ETR solenoid malfunctioning.</li> <li>● Engine trouble or out of fuel.</li> </ul>	<ul style="list-style-type: none"> <li>● All interlock switches are OK; therefore, proceed to next cause.</li> <li>● Refer to Rear Camshaft Adjustment, page 33.</li> <li>● Repair or replace.</li> <li>● Check fuel lines and filter.</li> <li>● Connect wire.</li> <li>● Check connections, test solenoid. Replace, if necessary.</li> <li>● Determine problem and correct.</li> </ul>
6. Engine does not stop when mow pedal is depressed (reels engaged) and operator gets off the seat.	<ul style="list-style-type: none"> <li>● Mow/lift or seat switch adjusted incorrectly or are malfunctioning.</li> <li>● Seat return pin spring broken, missing or jammed down.</li> <li>● Seat pivot fails to rotate freely.</li> </ul>	<ul style="list-style-type: none"> <li>● Refer to Installing and Adjusting Mow/Lift Switch, page 28.</li> <li>● Refer to Installing and Adjusting Seat Switch, page 27.</li> <li>● Replace, loosen and lubricate parts so pin operates freely.</li> <li>● Loosen and lubricate seat pivot pin to assure free movement.</li> </ul>
7. Engine does not stop when shift selector is in gear and operator gets off the seat.	<ul style="list-style-type: none"> <li>● Traction or seat switch adjusted incorrectly or are malfunctioning.</li> <li>● Seat return pin spring broken, missing or jammed down.</li> </ul>	<ul style="list-style-type: none"> <li>● Refer to Installing and Adjusting Traction Switch, page 28.</li> <li>● Refer to Installing and Adjusting Seat Switch, page 27.</li> <li>● Replace, loosen and lubricate parts so pin operates freely.</li> </ul>

# MAINTENANCE — TROUBLE SHOOTING

CONDITION	CAUSE	CORRECTION
7. Engine does not stop when shift selector is in gear as you get off the seat (continued).	<ul style="list-style-type: none"> <li>● Seat pivot fails to rotate freely.</li> </ul>	<ul style="list-style-type: none"> <li>● Loosen and lubricate seat pivot pin to assure free movement.</li> </ul>
8. Engine does not continue to run when sitting on seat and shift selector is placed in gear or mow pedal is depressed.	<ul style="list-style-type: none"> <li>● Seat switch adjusted incorrectly or is malfunctioning.</li> <li>● Seat return pin spring jammed in up position.</li> </ul>	<ul style="list-style-type: none"> <li>● Refer to Installing and Adjusting Seat Switch, page 27.</li> <li>● Loosen and lubricate jammed parts so pin operates freely. Replace spring if broken or damaged.</li> </ul>
9. Engine stops regardless of shift selector or mow pedal position (even if both are in "Neutral") as operator gets off the seat.	<ul style="list-style-type: none"> <li>● Mow/lift switch and/or Traction switch adjusted incorrectly or are malfunctioning.</li> <li>● Mow/lift and/or traction switch wires are loose.</li> <li>● "B" terminal wire of key switch is loose.</li> </ul>	<ul style="list-style-type: none"> <li>● Refer to Installing and Adjusting Switches, page 28.</li> <li>● Connect wires.</li> <li>● Connect wires.</li> </ul>
10. Engine "cuts-out" during transport.	<ul style="list-style-type: none"> <li>● Seat is lifting off seat switch button too easily.</li> </ul>	<ul style="list-style-type: none"> <li>● Adjust seat switch: refer to Installing and Adjusting Seat Switch, page 27.</li> <li>● Instruct operator to sit back in seat during transport.</li> </ul>
11. Engine does not stop when ignition key is rotated to OFF position.	<ul style="list-style-type: none"> <li>● Connector off ignition switch.</li> <li>● ETR solenoid malfunctioning.</li> <li>● Ignition switch is malfunctioning.</li> <li>● Wires in connector have shorted.</li> </ul>	<ul style="list-style-type: none"> <li>● Push connector onto ignition switch terminals.</li> <li>● Replace if necessary.</li> <li>● Replace ignition switch.</li> <li>● Repair affected wires.</li> </ul>
12. Battery does not charge.	<ul style="list-style-type: none"> <li>● Loose wire(s) in electrical system.</li> <li>● Malfunctioning alternator.</li> <li>● Faulty battery.</li> </ul>	<ul style="list-style-type: none"> <li>● Check all connections and make all necessary repairs.</li> <li>● Check alternator belt tension. Replace alternator, if necessary.</li> <li>● Replace, if necessary.</li> </ul>

# MAINTENANCE

## SERVICING THE HYDRAULIC SYSTEM

**DAILY CHECKS:** Check the hydraulic fluid level daily. Replenish with Mobil DTE26 as necessary. Also, check daily for leaks, chafed or otherwise damaged hoses and make sure there are no kinks, sharp bends or twists in any flexible line. Repair or replace as necessary (Fig. 44).



### CAUTION

Keep body and hands away from pin hole leaks or nozzles that eject hydraulic fluid under high pressure. Use paper or cardboard, not hands, to search for leaks. Hydraulic fluid escaping under pressure can have sufficient force to penetrate skin and do serious damage. If fluid is injected into the skin it must be surgically removed within a few hours by a doctor familiar with this form of injury or gangrene may result. Before disconnecting or performing any work on the hydraulic system, all system pressure must be relieved by stopping the engine and lowering the implement to the ground.

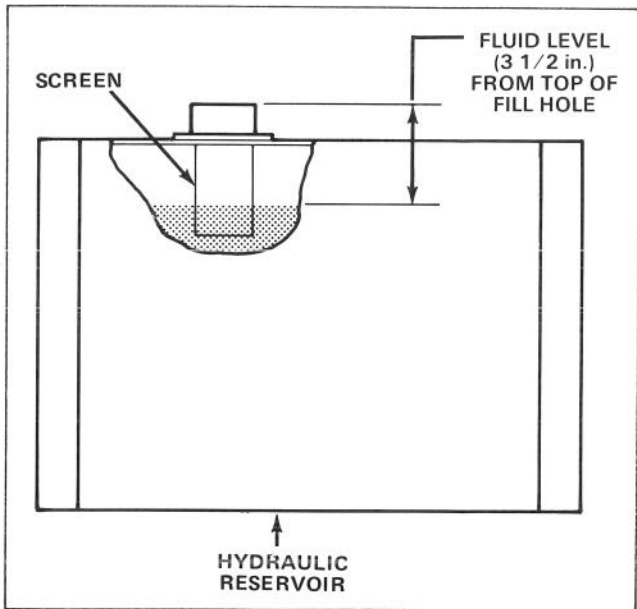

Figure 44

**GENERAL MAINTENANCE:** Before installing a new or rebuilt pump, valve, or hydraulic motor, charge it with Mobil DTE26 hydraulic fluid. Replace any felt strips under the reservoir straps which become damaged or out of place (Fig. 45).

**FLEXIBLE HYDRAULIC LINES:** There are twenty-eight (28) flexible hydraulic lines on the Greensmaster

3000-D. These lines are subject to pressure differentials during operation and exposed to extreme variables, such as weather, sun, chemicals, extremely warm storage conditions or mishandling during operation or maintenance that can cause damage or premature deterioration. Some lines are more susceptible to these conditions; i.e., the reel drive motor lines. Therefore, it is wise to inspect the lines frequently for signs of deterioration or damage and conduct a preventive maintenance program wherein hoses are periodically replaced, regardless of condition.

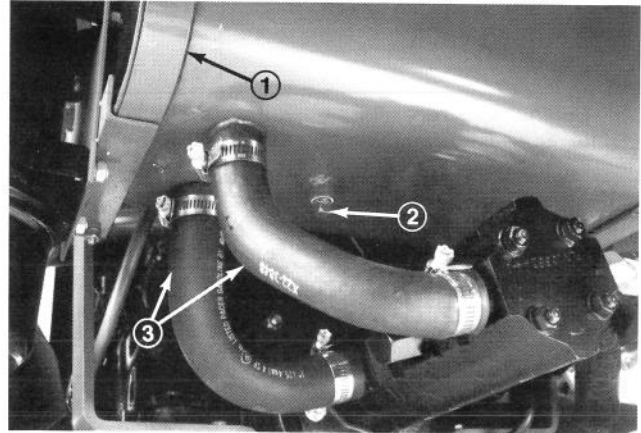

Figure 45

1. Felt strips under straps
2. Reservoir drain plug
3. Pump section lines

**IMPORTANT:** When disassembling hydraulic lines make sure hydraulic plugs are placed in the open end of the hydraulic line to prevent foreign debris from contaminating hydraulic fluid. It is also a good idea to tag hydraulic lines when disassembling so they can be properly reassembled. Keep all hydraulic and suction lines clean and free from debris. During replacement avoid overtightening fittings. Check hydraulic lines for breaks or cracks. Check the hydraulic reservoir for level of hydraulic fluid after replacement of any large component.

## SERVICING CUTTING UNIT

Remove the reel motor and store in support tubes on front of frame when sharpening, setting height-of-cut, or when performing other maintenance procedures on the cutting units, to prevent damage to the hoses.

## DRAINING RESERVOIR (Fig. 45)

Tools Required: 7/16 in. wrench, drain pan.

Every 2000 hours, drain and replace the fluid in the hydraulic reservoir. Use the following procedures:

# MAINTENANCE

**Note:** Due to location of the drain plug, special precautions should be taken to avoid spilling fluid onto the pump suction lines (Fig. 45).

1. Place a drain pan under the reservoir and remove the drain plug. Completely drain the reservoir and replace the plug.

**Note:** Only the reservoir needs to be drained.

**IMPORTANT: Do not operate the Greensmaster 3000-D while the fluid is being drained; damage to the hydraulic system may result.**

2. Refill the reservoir with Mobil DTE26 hydraulic fluid until it is 4 in. to 4-1/2 in. (10.2 to 11.4 cm) from the top of the reservoir (Fig. 44).

3. Start the machine and run it at idle for 3 to 5 minutes to circulate the fluid and remove any air trapped in the system. Stop the machine and recheck the fluid level. Add fluid, if necessary.

## FLUID CONTAMINATION DUE TO COMPONENT FAILURE

Failure of a pump or motor may contaminate the hydraulic fluid with wear particles that may damage other components. Therefore, it may be advisable to drain the contaminated fluid from reservoir, flush reservoir with No. 2 fuel oil and install new filter in addition to replacing the faulty component.

Before operating machine, run the engine at idle with all controls in neutral for 3 to 5 minutes.

## HYDRAULIC FILTER (Fig. 46)

Tools Required: Drain pan.

Replace the filter every 2000 hours. Use the following procedures:

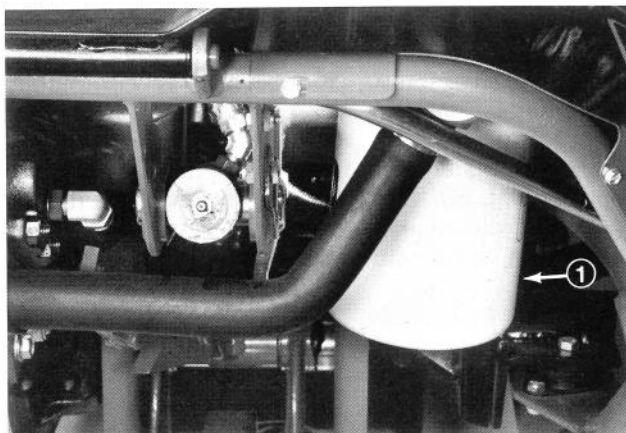

Figure 46

1. Hydraulic filter

1. Set the machine so the front is elevated 3 to 6 in. (7.6 to 15.2 cm) to prevent the fluid from draining out of the reservoir through the filter head.

2. Place a drain pan under the filter and remove the filter.

3. Fill the replacement filter with Mobil DTE 26 hydraulic fluid, lubricate the sealing gasket and hand turn until gasket contacts filter head. Then tighten three quarter turns further. Filter should now be sealed.

4. Start the engine and check for leaks.

## REAR CAMSHAFT ADJUSTMENT

Tools Required: 7/16 in. wrench.

A camshaft misaligned with the valve bank may cause the following:

- A. No increase in ground speed in No. 2 (transport) traction selection.
- B. Mow pedal will not stay depressed (in detent) without foot pressure.
- C. Slow lift of the cutting units.
- D. Slow or no drive to the cutting units.

If one or more malfunctions occur, loosen the rear camshaft mounting capscrews and relocate the camshaft until the condition is corrected (Fig. 47).

Retighten the capscrews.



### CAUTION

You must readjust the mow-lift switch when the camshaft adjustment is completed, page 33, and the lift and mow pedal height, page 34.



Figure 47

1. Mounting capscrews  
2. Cam blocks

# MAINTENANCE

## ADJUSTING LIFT AND MOW PEDAL HEIGHT

Tools Required: Pliers, 1/2 in. wrench.

Adjust the lift and mow pedal to equal height to gain proper spool travel in the valve bank as follows:

1. Place 1, 2 and 3 spools in neutral (center of travel) and remove transfer rod guard from foot panel (Fig. 48).

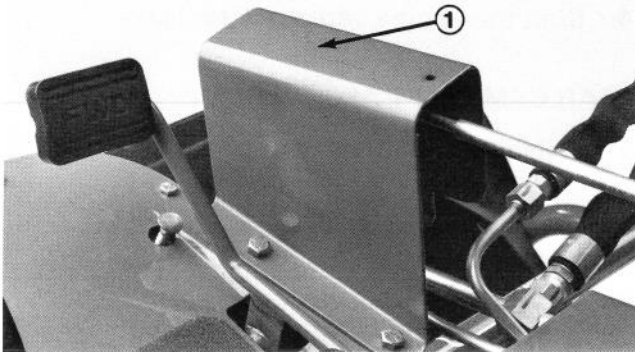

Figure 48

1. Transfer rod guard

2. Loosen jam nut securing yoke on front of long control rod, remove cotter pin and clevis pin. (Fig. 49).

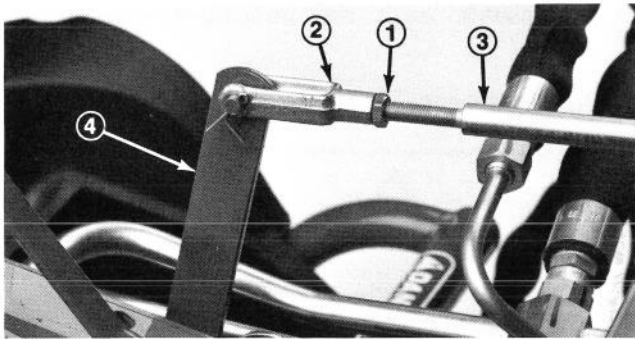

Figure 49

1. Jam nut  
2. Yoke  
3. Control rod  
4. Adjustment lever

3. Move adjustment lever by hand to level the mow and lift pedals and adjust yoke on control rod until hole in yoke lines up with the adjustment lever hole.

4. Install the clevis pin and cotter pin. Tighten the jam nut and install the transfer rod guard (Fig. 48).

5. Actuate the mow pedal by hand. Be sure the lift pivot under the pedals clears the stop welded to the frame, thereby allowing full spool travel.

## ADJUSTING TRACTION PEDAL

Tools Required: 1/2" Open end wrench and ruler.

To check forward and reverse operation of traction pedal proceed as follows:

### Forward

1. Press traction pedal fully forward until No. 5 section, valve spool is completely pulled out.

2. Pedal should contact pedal stop. If pedal contacts stop before spool is completely out, or if pedal does not make contact with stop, an adjustment to the stop is necessary (Fig. 50).

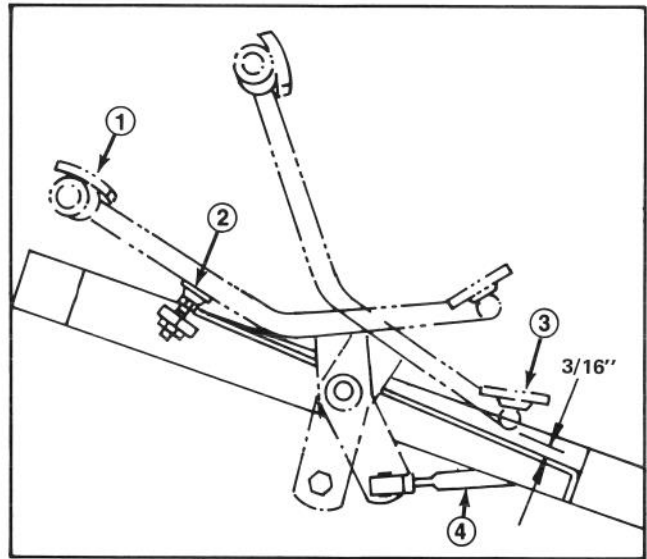

Figure 50

1. Fully forward 3. Reverse  
2. Pedal stop 4. Control rod

3. Loosen hex nut securing threaded rod to frame. Turn flange nut on rod to raise or lower stop (rod), while checking pedal.

4. When completed, retighten nut.

### Reverse

1. Press down on rear of traction pedal (reverse) until No. 5 section, spool valve is completely pushed in.

2. Check distance between bottom of pedal and footrest (Fig. 50). Distance should be approximately 3/16". If distance is greater or less than 3/16" dimension, an adjustment to the traction control rod is required.

3. Remove jamnut and balljoint securing control rod to traction shaft pivot.

4. Loosen jamnuts securing balljoints to control rod and adjust balljoints and control rod to attain 3/16" dimension when reinstalled.

# MAINTENANCE

## ADJUSTING CUTTING UNIT LIFT/DROP

The machines cutting unit lift/drop circuit is equipped with a flow control valve. This valve is pre-set at the factory, but a slight adjustment may be required to compensate for differences in hydraulic oil temperatures, mowing speeds, etc. If an adjustment is required, proceed as follows:

1. Raise seat and locate flow control above valve.
2. Loosen jam nut, retaining adjusting knob on flow control. **When loosening jam nut, hold flow control knob to prevent it from rotating.**
3. Rotate knob 1/4 turn counterclockwise, if center cutting unit is dropping too late or 1/4 turn clockwise, if center cutting unit is dropping too early.
4. After desired setting has been achieved, hold

knob to prevent any rotation and tighten jam nut.

## ADJUSTING LIFT CYLINDERS

To regulate the height of the front cutting units, when in the raised (transport) position, the front lift cylinders may be adjusted.

1. Lower cutting units to the floor.
2. Loosen jam nut on clevis, of cutting unit lift cylinder, to be adjusted.
3. Disconnect cylinder clevis from lift arm.
4. Rotate clevis until desired height is attained.
5. Connect cylinder clevis to lift arm and tighten jam nut.

## HYDRAULIC SCHEMATIC

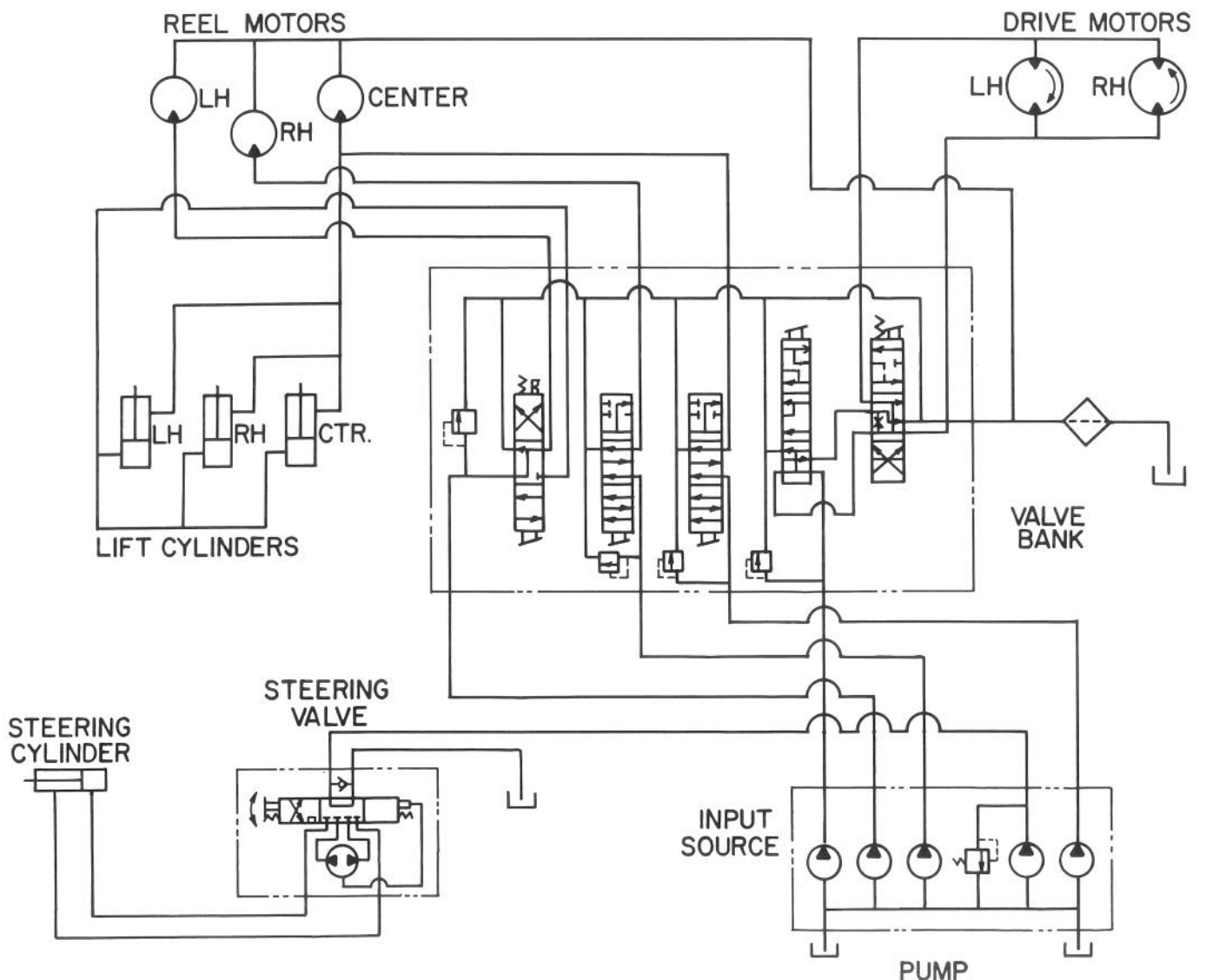

# MAINTENANCE — TROUBLE SHOOTING

CONDITION	CAUSE	CORRECTION
<b>ENGINE:</b> 1. Loss of power	<ul style="list-style-type: none"> <li>● Out of fuel.</li> <li>● Debris in fuel tank — clogged fuel line.</li> <li>● Clogged fuel filter/water separator</li> <li>● Clogged fuel pump filter</li> <li>● Low crankcase oil level</li> <li>● Wrong oil in crankcase</li> <li>● Throttle linkage set incorrectly</li> <li>● Plugged air cleaner</li> <li>● Engine fuel system malfunction.</li> <li>● Cooling system malfunction: engine overheating</li> <li>● Internal engine malfunction</li> <li>● Engine-pump coupling loose</li> <li>● Hydraulic system malfunctioning</li> </ul>	<ul style="list-style-type: none"> <li>● Refill fuel tank. Bleed air from fuel system.</li> <li>● Clean fuel tank. Use clean diesel fuel.</li> <li>● Drain separator and/or replace filter.</li> <li>● Clean or replace filter.</li> <li>● Add oil to proper level. Check level more often.</li> <li>● Replace with correct oil. Refer to engine manual.</li> <li>● Adjust as necessary.</li> <li>● Service more frequently.</li> <li>● Repair as necessary.</li> <li>● Repair as necessary.</li> <li>● Repair as necessary.</li> <li>● Repair or replace.</li> <li>● Refer to Hydraulic Trouble shooting.</li> </ul>
2. Engine won't start	<ul style="list-style-type: none"> <li>● No fuel</li> <li>● Wrong fuel</li> <li>● Air in fuel system</li> <li>● Malfunctioning start system</li> </ul>	<ul style="list-style-type: none"> <li>● Check fuel level; add fuel to tank.</li> <li>● Use No. 2-D or 1-D diesel fuel with min. 40 cetane reading.</li> <li>● Bleed system.</li> <li>● Check battery, connections, solenoid, starter motor.</li> </ul>
<b>HYDRAULIC:</b> No ground speed increase in #2 selection.	<ul style="list-style-type: none"> <li>● Maladjusted control lever.</li> <li>● Maladjusted rear camshaft.</li> <li>● Mow-lift linkage binding or broken lift pivot spring.</li> <li>● Wrong detent parts in #4 spool.</li> <li>● #2 or #3 spool relief valves stuck open. (Reel drive RPM will also be low on #1 or #3 cutting unit).</li> </ul>	<ul style="list-style-type: none"> <li>● Adjust. Refer to Traction Switch Adjustment, page 28.</li> <li>● Adjust by moving R.H. end of rear camshaft forward or L.H. end rearward. Refer to page 33.</li> <li>● Lubricate or repair machine.</li> <li>● Remove valve bank &amp; repair #4 spool assembly.</li> <li>● Remove, and repair or replace cartridge.</li> </ul>
No #1 or Reverse Traction speed. Normal #2 speed.	<ul style="list-style-type: none"> <li>● Faulty or missing disc seal between #3 or #4 valve sections.</li> <li>● Poppet inside #4 spool stuck open. Off seat.</li> </ul>	<ul style="list-style-type: none"> <li>● Remove valve bank. Replace disc seal.</li> <li>● Remove valve bank. Repair #4 spool section.</li> </ul>

# MAINTENANCE — TROUBLE SHOOTING

CONDITION	CAUSE	CORRECTION
No #1 or reverse traction speed. Slow in #2.	<ul style="list-style-type: none"> <li>● Open traction relief cartridge in #4 spool section.</li> <li>● Traction motor lacks efficiency. Fluid leaking past internal gears.</li> <li>● Hydraulic pump lacks efficiency. Fluid leaking past internal gears.</li> <li>● Contamination in one or both suction lines at reservoir end.</li> </ul>	<ul style="list-style-type: none"> <li>● Remove relief cartridge. Repair or replace.</li> <li>● Test to identify faulty motor. Repair or replace motor.</li> <li>● Test to verify diagnosis. Repair or replace pump.</li> <li>● Drain reservoir &amp; clean thoroughly.</li> </ul>
Slow or no traction in all selections.  (Reels also affected)	<ul style="list-style-type: none"> <li>● Brakes dragging.</li> <li>● Faulty O-ring seals around traction relief cartridge or inlet sleeve in #4 spool valve. Fluid leaking by to tank.</li> <li>● Worn or weak traction motor(s).</li> <li>● Pump excessively worn.</li> <li>● Traction relief in #4 spool valve open.</li> <li>● Large amount of debris in reservoir. Suction line partially blocked.</li> </ul>	<ul style="list-style-type: none"> <li>● Determine cause &amp; repair.</li> <li>● Remove relief and inlet sleeve. Replace O-rings.</li> <li>● Test to verify. Repair or replace motor(s).</li> <li>● Test to verify. Repair or replace.</li> <li>● Remove, repair or replace.</li> <li>● Drain reservoir. Remove blockage.</li> </ul>
	<ul style="list-style-type: none"> <li>● Low oil level in reservoir.</li> <li>● Loose shift lever bracket.</li> <li>● Maladjusted rear camshaft.</li> <li>● Engine lacks power.</li> </ul>	<ul style="list-style-type: none"> <li>● Add oil to proper level. See page 32.</li> <li>● Readjust &amp; tighten shift lever. See page 33.</li> <li>● Readjust. See page 33.</li> <li>● Repair as necessary.</li> </ul>
Binding shift lever.	<ul style="list-style-type: none"> <li>● Lack of lubrication in #4 spool detent assembly.</li> </ul>	<ul style="list-style-type: none"> <li>● Remove valve bank. Disassemble detent assembly &amp; repair.</li> </ul>
All 3 cutting units raise and lower too slowly.	<ul style="list-style-type: none"> <li>● Binding lift cylinders &amp; linkages. (lack of lubrication).</li> </ul>	<ul style="list-style-type: none"> <li>● Lubricate more frequently. Refer to page 19.</li> </ul>
Cutting units lift too slowly.	<ul style="list-style-type: none"> <li>● Rear camshaft maladjusted.</li> <li>● #2 spool travel restricted by mow-lift switch.</li> <li>● Lift check poppet in #1 spool section stuck partially closed.</li> </ul>	<ul style="list-style-type: none"> <li>● Readjust. Refer to page 33.</li> <li>● Readjust switch. See page 28.</li> <li>● Remove lift check. Repair or replace.</li> </ul>
Power Steering operates poorly.	<ul style="list-style-type: none"> <li>● Castor wheel bearings maladjusted.</li> <li>● Faulty power steering cartridge.</li> <li>● Inefficient hydraulic pump.</li> <li>● Faulty steering control valve.</li> <li>● Steering cylinder leaks internally.</li> </ul>	<ul style="list-style-type: none"> <li>● Readjust bearings.</li> <li>● Repair or replace.</li> <li>● Test pump; repair or replace.</li> <li>● Test valve; repair or replace.</li> <li>● Repair or replace cylinder.</li> </ul>

# MAINTENANCE – TROUBLE SHOOTING

CONDITION	CAUSE	CORRECTION
Cutting units drop during transport (between greens)	<ul style="list-style-type: none"> <li>● Internal lift cylinder leak.</li> <li>● Lift check plug seals in #1 spool body faulty.</li> <li>● Detent stud loose in #1 spool.</li> <li>● #1 spool loose in valve body. Fluid bypassing.</li> </ul>	<ul style="list-style-type: none"> <li>● Raise units &amp; block them up. Remove lines from brazed tube &amp; remove blocks. Line which leaks fluid is attached to bad cylinder. Repair cylinder.</li> <li>● Remove lift check plugs. Replace O-ring assemblies.</li> <li>● Remove adjustment cap from #1 spool bonnet. Retighten stud with screwdriver.</li> <li>● Replace spool valve assembly.</li> </ul>
Cutting units drop while machine is stored. (Overnight)	<ul style="list-style-type: none"> <li>● Normal condition.</li> </ul>	<ul style="list-style-type: none"> <li>● No repair necessary.</li> </ul>
One or more cutting units slow or no reel drive action.	<ul style="list-style-type: none"> <li>● Bedknife to reel adjustment too tight.</li> <li>● Tight reel bearings.</li> <li>● Rear camshaft maladjusted.</li> <li>● Poppet in relief cartridge off seat.</li> <li>● Clogged pump suction line.</li> <li>● Improper suction line(s) installed. Line collapsed.</li> <li>● Blockage in line fitting.</li> <li>● Excessively worn motor.</li> <li>● Slow reel rpm – No. 1 C.U.</li> <li>● Excessively worn pump.</li> <li>● Spool loose in valve body. Fluid leak past spool.</li> <li>● Steel pressure line damaged. Flow restricted. (Front cutting units only).</li> <li>● Low fluid level. (Will affect total machine performance).</li> </ul>	<ul style="list-style-type: none"> <li>● Readjust per instructions in Operator's Manual for cutting unit.</li> <li>● Repair as necessary.</li> <li>● Readjust. See page 33.</li> <li>● Remove and repair or replace relief cartridge.</li> <li>● Drain reservoir. Clean out obstruction.</li> <li>● Remove. Use genuine TORO parts only.</li> <li>● Repair as necessary.</li> <li>● Test to verify. Repair or replace motor.</li> <li>● Check lift cylinders for internal leakage. Repair or replace.</li> <li>● Test to verify. Repair or replace.</li> <li>● Replace spool valve assembly.</li> <li>● Replace line.</li> <li>● Add fluid. Refer to page 32.</li> </ul>
Center cutting unit (#1) reel operates in raised position.	<ul style="list-style-type: none"> <li>● Rear camshaft maladjusted. #3 spool too far out of body.</li> <li>● Restriction in brazed tube assembly on #3 spool section.</li> <li>● Restriction in valve return port between #3 spool section and R.H. cover.</li> </ul>	<ul style="list-style-type: none"> <li>● Readjust camshaft. See page 33.</li> <li>● Remove restriction.</li> <li>● Disassemble cover &amp; remove restriction.</li> </ul>
Reel drive pressure lines pulsate during operation.	<ul style="list-style-type: none"> <li>● Normal condition. Will vary from line to line.</li> </ul>	<ul style="list-style-type: none"> <li>● No repair necessary.</li> </ul>
Mow pedal won't stay down unless held down with foot. (#1 spool not in "detent").	<ul style="list-style-type: none"> <li>● Rear camshaft maladjusted.</li> <li>● Faulty #1 spool detent.</li> </ul>	<ul style="list-style-type: none"> <li>● Readjust camshaft. See page 33.</li> <li>● Remove and repair.</li> </ul>

# STORAGE INSTRUCTIONS

If you wish to store the GREENSMaster 3000-D for a long period of time, the following steps should be accomplished prior to storage:

1. Remove accumulations of dirt and old grass clippings. Sharpen reels and bedknives, if necessary; refer to Cutting Unit Operator's Manual. Use a rust preventive on bedknives and reel blades. Grease and oil all lubrication points: refer to Lubrication, page 19.
2. Block up wheels to remove weight on tires.
3. Drain and replace hydraulic fluid and filter, inspect hydraulic lines and fittings. Replace, if necessary; refer to Servicing The Hydraulic System, page 32.
4. Drain diesel fuel from the fuel tank, fuel lines, pump, filter and separator. Flush fuel tank with clean diesel fuel and connect all fuel lines.
5. While engine is still warm, drain oil from crankcase. Change oil filter. Refill with fresh oil; refer to Lubrication and Service Interval Chart, page 19, 21.
6. Drain coolant from radiator, engine and expansion tank. Flush system and refill with 50/50 solution of water and anti-freeze; refer to Changing Coolant in Cooling System, page 25.
7. Service the air cleaner; refer to Air Cleaner Maintenance, page 21.
8. If possible, store in a warm, dry location.

## IDENTIFICATION AND ORDERING

### MODEL AND SERIAL NUMBERS

The GREENSMaster 3000-D has two identification numbers: a model number and a serial number. The two numbers are stamped on a plate which is riveted on top of the right rear frame tube. In any correspondence concerning the GREENSMaster 3000-D, supply model and serial numbers to be sure that correct information and replacement parts are obtained.

To order replacement parts from an authorized TORO Distributor, supply the following information:

1. Model and serial numbers of the machine.
2. Part number, description and quantity of parts desired.

**Note:** Do not order by reference number if a parts catalog is being used; use the part number.

# The Toro Promise

## A ONE YEAR LIMITED WARRANTY

*The Toro Company promises to repair your TORO Product if defective in materials or workmanship. The following time periods from the date of purchase apply:*

Commercial Products . . . . . 1 Year

*The costs of parts and labor are included, but the customer pays the transportation costs on walk rotary mowers with cutting unit widths of less than 25".*

If you feel your TORO product is defective and wish to rely on The Toro Promise, the following procedure is recommended:

1. Contact your Authorized TORO Distributor or Commercial Dealer (the Yellow Pages of your telephone directory is a good reference source).
2. The TORO Distributor or Commercial Dealer will advise you on the arrangements that can be made to inspect and repair your product.
3. The TORO Distributor or Commercial Dealer will inspect the product and advise you whether the product is defective and, if so, make all repairs necessary to correct the defect without an extra charge to you.

If for any reason you are dissatisfied with the distributor's analysis of the defect or the service performed, you may contact us.

Write:

TORO Commercial Products Service Department  
8111 Lyndale Avenue South  
Minneapolis, Minnesota 55420

The above remedy of product defects through repair by an Authorized TORO Distributor or Commercial Dealer is the purchaser's sole remedy for any defect.

**THERE IS NO OTHER EXPRESS WARRANTY. ALL IMPLIED WARRANTIES OF MERCHANTABILITY AND FITNESS FOR USE ARE LIMITED TO THE DURATION OF THE EXPRESS WARRANTY.**

Some states do not allow limitations on how long an implied warranty lasts, so the above limitation may not apply to you.

This Warranty applies only to parts or components which are defective and does not cover repairs necessary due to normal wear, misuse, accidents, or lack of proper maintenance. Regular, routine maintenance of the unit to keep it in proper condition is the responsibility of the owner.

All warranty repairs reimbursable under the Toro Promise must be performed by an Authorized TORO Commercial Dealer or Distributor using Toro approved replacement parts.

Repairs or attempted repairs by anyone other than an Authorized TORO Distributor or Commercial Dealer are not reimbursable under the Toro Promise. In addition, these unauthorized repair attempts may result in additional malfunctions, the correction of which is not covered by warranty.

**THE TORO COMPANY IS NOT LIABLE FOR INDIRECT, INCIDENTAL OR CONSEQUENTIAL DAMAGES IN CONNECTION WITH THE USE OF THE PRODUCT INCLUDING ANY COST OR EXPENSE OF PROVIDING SUBSTITUTE EQUIPMENT OR SERVICE DURING PERIODS OF MALFUNCTION OR NON-USE.**

Some states do not allow the exclusion or limitation of incidental or consequential damages, so the above limitation or exclusion may not apply to you.

This warranty gives you specific legal rights, and you may also have other rights which vary from state to state.

### COUNTRIES OTHER THAN THE UNITED STATES OR CANADA

Customers who have purchased TORO products exported from the United States or Canada should contact their TORO Distributor (Dealer) to obtain guarantee policies for your country, province or state. If for any reason

you are dissatisfied with your Distributor's service or have difficulty obtaining guarantee information, contact the TORO importer. If all other remedies fail, you may contact us at The Toro Company.