



MODEL NO. 08883 - 40001
THRU 60001 & Up

OPERATOR'S
MANUAL

SAND PRO® 3000

To assure maximum safety, optimum performance, and to gain knowledge of the product, it is essential that you or any other operator of the machine read and understand the contents of this manual before the engine is ever started. Pay particular attention to the SAFETY INSTRUCTIONS highlighted by this symbol—



The safety alert symbol means CAUTION, WARNING or DANGER — personal safety instruction. Failure to comply with the instruction may result in personal injury.



FOREWORD

The SAND PRO 3000 was developed to provide an efficient, trouble free and economical method of sand trap maintenance. The latest concepts of engineering, design and safety have been incorporated into this machine, along with the highest quality parts and workmanship. Excellent service will be derived if proper operation and maintenance practices are followed.

You know, since you have purchased the industry leader in sand trap and other maintenance excellence, that future performance and dependability are of prime importance. TORO also is concerned about future use of the machine and of safety to the user. Therefore, this manual must be read by you and those involved with the SAND PRO 3000 to make sure that safety, proper set-up, operation and maintenance procedures are followed at all times. The major sections of the manual are:

1. Safety Instructions
2. Set-Up Instructions

3. Before Operating
4. Operating Instructions

5. Maintenance

Safety, mechanical and some general information in this manual are emphasized. **DANGER**, **WARNING** and **CAUTION** identify safety messages. Whenever the triangle safety symbol appears, it is followed by a safety message that must be read and understood. For more details concerning safety, read the safety instructions on pages 4 and 5. **IMPORTANT** identifies special mechanical information and **NOTE** identifies general information worthy of special attention.

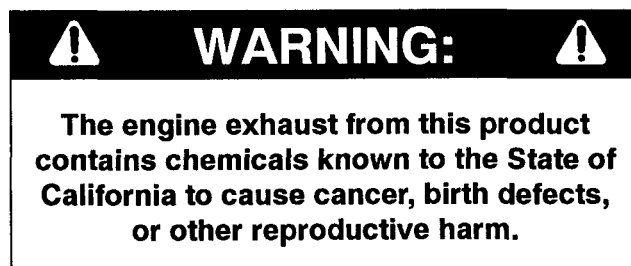

OPTIONAL SPARK ARRESTER

In some areas there are local, state or federal regulations requiring a spark arrester muffler must be used on the engine of this machine. If a spark arrester is required, order the following part(s) from your local Toro Distributor.

(1) 51-0990 Spark Arrester Assembly

These parts are approved by the United States Department of Agriculture and the United States Forest Service.

When the machine is used or operated on any California forest, brush or grass covered land, a properly operating spark arrester must be attached to the muffler. The operator is violating state law, Section 442 Public Resources Code if a spark arrester is not used.

If help concerning set up, operation, maintenance or safety is ever needed, contact your local Authorized TORO Distributor. In addition to genuine TORO replacement parts, the distributor also has optional equipment for the complete line of TORO turf care equipment. Keep your Toro all TORO. Buy genuine TORO parts and accessories.

TABLE OF CONTENTS

SAFETY INSTRUCTIONS	4-5	DAILY MAINTENANCE CHECKLIST	15
SAFETY AND INSTRUCTION DECALS	6	MAINTENANCE	16-21
SPECIFICATIONS	7	Lubrication	16
LOOSE PARTS CHART	7	Changing Crankcase Oil	16
SET-UP INSTRUCTIONS	8-9	Servicing Air Cleaner	16
Install Wheels	8	Adjusting Carburetor	17
Install Steering Wheel	8	Checking and Replacing Spark Plug	17
Push Unit Off Pallet	8	Cleaning Cylinder Head Fins	18
Activate and Charge Battery	8	Changing Hydraulic System Oil and Filter	18
Install Battery	9	Checking Hydraulic Lines and Hoses	19
Install Refuse Container	9	Charging Hydraulic System	19
BEFORE OPERATING	10-11	Adjusting Steering Chain	20
Check Crankcase Oil	10	Replacing Fuel Filter	20
Fill Fuel Tank	10	Adjusting Traction Drive for Neutral	20
Check Hydraulic System	11	Adjusting Traction Interlock Switch	21
Check Tire Pressure	11	Adjusting Pedal for Reverse	21
KNOW YOUR CONTROLS	12-13	Battery Storage	21
OPERATING INSTRUCTIONS	13-14	Battery Care	21
Starting/Stopping Engine	13	HYDRAULIC SCHEMATIC	22
Check Interlock System	13	ELECTRICAL SCHEMATIC	22
Towing Sand Pro	14	MAINTENANCE SCHEDULE	23
Break-in Period	14	IDENTIFICATION AND ORDERING	23
Operating Characteristics	14	THE TORO PROMISE	BACK COVER
Inspection and Clean-Up	14		



SAFETY INSTRUCTIONS

The SAND PRO 3000 was designed and tested to offer safe service when operated and maintained properly. Although hazard control and accident prevention partially are dependent upon the design and configuration of the machine, these factors are also dependent upon the awareness, concern, and proper training of the personnel involved in the operation, transport, maintenance, and storage of the machine. Improper use or maintenance of the machine can result in injury or death. To reduce the potential for injury or death, comply with the following safety instructions.

BEFORE OPERATING

1. Operate the machine only after reading and understanding the contents of this manual. A replacement manual is available by sending complete model and serial number to: The Toro Company, 8111 Lyndale Avenue South, Minneapolis, Minnesota 55420.
2. Never allow children to operate the machine or adults to operate it without proper instructions.
3. Become familiar with the controls and know how to stop the engine quickly.
4. Keep all shields, safety devices and decals in place. If a shield, safety device or decal is malfunctioning, illegible, or damaged, repair or replace it before operating the machine.
5. Always wear substantial shoes. Do not operate machine while wearing sandals, tennis shoes or sneakers. Do not wear loose fitting clothing which could get caught in moving parts and cause personal injury.
6. Wearing safety glasses, safety shoes, long pants and a helmet is advisable and required by some local safety and insurance regulations.
7. Ensure traction interlock switch is adjusted correctly so engine cannot be started unless traction pedal is released and in neutral position.
8. Keep everyone, especially children and pets away from the areas of operation.
9. Since gasoline is highly flammable, handle it carefully.
 - A. Use an approved gasoline container.
 - B. Do not remove cap from fuel tank when engine is hot or running.
 - C. Do not smoke while handling gasoline.
 - D. Fill fuel tank outdoors and to about one inch below top of tank, (bottom of filler neck). Do not overfill.

E. Wipe up any spilled gasoline.

10. Check the safety interlock system daily for proper operation; refer to page 13. If the switch should malfunction, replace the switch before operating machine. (After every two years, replace the interlock switch in the safety system, whether it is working properly or not.)

WHILE OPERATING

11. Exhaust fumes are hazardous and could be deadly, so do not run the engine in a confined area without adequate ventilation.
12. Sit on seat when operating the machine. Never carry passengers.
13. When starting the engine:
 - A. Make sure traction pedal is released.
 - B. After the engine is started, keep foot off traction pedal. Machine must not move. If movement is evident, the neutral return bracket is adjusted incorrectly; therefore, shut engine off and readjust bracket so machine does not move when in neutral position. If engine does not start, check interlock switch for proper adjustment.
14. Using the machine demands attention. To prevent tipping or loss of control:
 - A. Use care when entering and leaving sand traps. Use extreme caution around ditches, creeks or other hazards.
 - B. Watch for holes or other hidden hazards.
 - C. Use caution when operating machine on a steep slope. Reduce speed when making sharp turns or when turning on hillsides.
 - D. Avoid sudden stops and starts. Do not go from reverse to full forward without first coming to a complete stop.
 - E. Before backing up, look to the rear and assure no one is behind the machine.
 - F. Watch out for traffic when near of crossing roads. Always yield the right of way.
15. If optional Hitch Kit, model 08833, is installed on machine, vertical load on hitch should not exceed 200 lbs.
16. Do not touch engine, muffler or exhaust pipe while engine is running or soon after it has stopped because these areas are hot enough to cause burns.



SAFETY INSTRUCTIONS

17. If the machine ever vibrates abnormally, stop immediately, turn engine off, wait for all motion to stop and inspect for damage. Repair all damage before commencing operation.

18. Before getting off the seat:

A. Stop movement of the machine. Take precautions to prevent accidental starts, rolling away, etc.

B. Shut engine off and wait for all movement to stop.

19. Whenever machine is left unattended, be sure engine is stopped, implement is lowered and key is removed from ignition.

MAINTENANCE

20. Before servicing or making adjustments to the machine, stop the engine and pull the spark plug wire off spark plug to prevent accidental starting of the engine.

21. Make sure all hydraulic line connectors are tight, and all hydraulic hoses and lines are in good condition before applying pressure to the system.

22. Keep body and hands away from pin hole leaks or nozzles that eject hydraulic fluid under high pressure. Use paper or cardboard, not hands, to search for leaks. Hydraulic fluid escaping under pressure can have sufficient force to penetrate skin and do serious damage. If fluid is injected into the skin it must be surgically removed within a few hours by a doctor familiar with this form of injury or gangrene may result.

23. Before disconnecting or performing any work on the hydraulic system, all pressure in system must be relieved by stopping engine and lowering attachments to the ground.

24. To make sure entire machine is in good condition, keep all nuts, bolts and screws properly tightened.

25. If major repairs are ever needed or assistance is required, contact an Authorized TORO Distributor.

26. To reduce potential fire hazard, keep the engine area free of excessive grease, grass, leaves and accumulation of dirt.

27. If the engine must be running to perform a maintenance adjustment, keep hands, feet, clothing, and any parts of the body away from the engine and any moving parts. Keep everyone away.

28. Do not overspeed engine by changing governor settings. Maximum engine speed is 3200 rpm. To assure safety and accuracy, have an Authorized Toro Distributor check maximum engine speed with a tachometer.

29. Engine must be shut off before checking oil or adding oil to the crankcase.

30. To be sure of optimum performance and safety, always purchase genuine TORO replacement parts and accessories. Replacement parts and accessories made by other manufacturers could be dangerous. Such use could void the product warranty of The Toro Company.



SAFETY AND INSTRUCTION DECALS

The following safety and instruction decals are installed on the machine. If any become damaged or illegible, replace them. Decal part numbers are listed below and in the parts catalog. Order replacements from your Authorized Toro Distributor.

**SAND PRO 2000 & 3000
QUICK REFERENCE AID**

CHECK/SERVICE (DAILY)

1. OIL LEVEL, ENGINE
2. OIL LEVEL, HYDRAULIC TANK
3. TRACTION NEUTRAL INTERLOCK SWITCH
4. AIR FILTER & PRECLEANER
5. ENGINE COOLING FINS
6. TIRE PRESSURE (4-6 psi)
7. WHEEL NUT TORQUE (45 - 55 FT. LBS.)
8. BATTERY
9. LUBRICATION

FLUID SPECIFICATION/CHANGE INTERVALS

SEE OPERATOR'S MANUAL FOR INITIAL CHANGE	FLUID TYPE	CAPACITY	CHANGE INTERVALS		FILTER PART NO.
			FLUID	FILTER	
A. ENGINE OIL	SAE 30 SG	5 1/4 PTS	25 HRS.		
B. HYDRAULIC OIL	SAE 10W-30	3 GAL.	500 HRS.	500 HRS.	23-9740
C. AIR CLEANER				*100 HRS.	4506302
D. FUEL TANK/FILTER	UNLEADED GAS	4 1/4 GAL.	1000 HRS.		18-1520

*INSPECT OR REPLACE

**UNDER SEAT PLATE
(Part No. 92-8965)**



**ON VALVE SHROUD
(Part No. 63-8440)**



**ON ENGINE COUPLER SHIELD
(Part No. 76-8750)**

CAUTION

FAILURE TO COMPLY WITH THE FOLLOWING SAFETY INSTRUCTIONS MAY RESULT IN PERSONAL INJURY.

- FOR BRAKING, MOVE TRACTION PEDAL TO NEUTRAL OR DIRECTION OPPOSITE TRAVEL DIRECTION.
- KEEP PEOPLE AND PETS A SAFE DISTANCE AWAY FROM MACHINE.
- KEEP ALL GUARDS IN PLACE.
- NEVER PARK ON SLOPE.
- BEFORE LEAVING OPERATORS POSITION:
 - A) MOVE TRANSMISSION PEDAL TO NEUTRAL.
 - B) LOWER IMPLEMENTS TO GROUND.
 - C) SHUT OFF ENGINE.
 - D) REMOVE IGNITION KEY.
- WAIT FOR ALL MOVEMENT TO STOP BEFORE SERVICING.
- STOP ENGINE BEFORE ADDING FUEL OR REMOVING HOOD.
- NO SMOKING RECOMMENDED DURING OPERATION OR REFUELING.
- CHECK PERFORMANCE OF ALL INTERLOCK SWITCHES DAILY.
- SEE OPERATORS MANUAL FOR INSTRUCTIONS.
- DO NOT DEFEAT INTERLOCK SYSTEM. IT IS FOR YOUR PROTECTION.
- DO NOT GO FROM REVERSE TO FULL FORWARD WITHOUT FIRST COMING TO A COMPLETE STOP.
- AVOID SHARP TURNS AT TRANSPORT SPEED.
- USE CAUTION WHEN OPERATING UNIT ON A STEEP SLOPE.

TOWING INSTRUCTIONS

- IMPROPER TOWING CAN CAUSE DAMAGE ON THIS MACHINE.
- BEFORE TOWING, SEE OPERATORS MANUAL FOR SPECIFIC INSTRUCTIONS.

BEFORE OPERATING THIS MACHINE, READ AND UNDERSTAND OPERATORS MANUAL AND SAFETY INSTRUCTIONS. REPLACEMENT MANUAL AVAILABLE BY SENDING COMPLETE MODEL NUMBER TO: THE TORO CO., 8111 LYNDALE AVE., BLOOMINGTON, MN 55420-1196.

**ON ENGINE SHIELD
(Part No. 92-1706)**

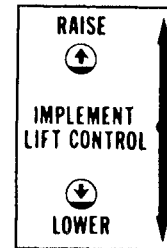

**ON VALVE SHROUD
(Part No. 80-1910)**

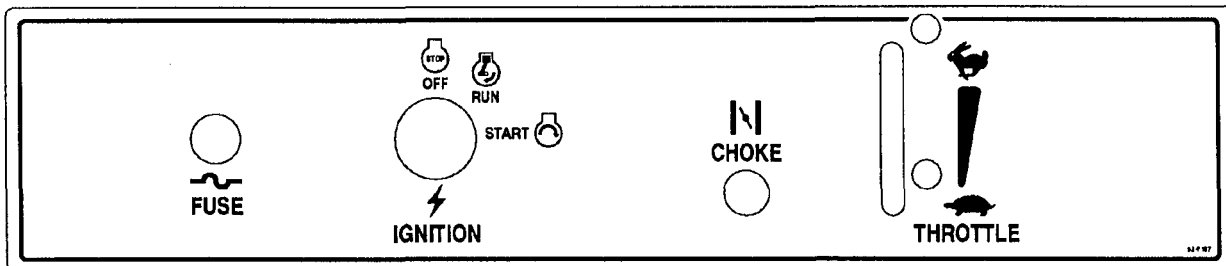

**ON DASH PANEL
(Part No. 92-7157)**

SPECIFICATIONS

Configuration: Short wheel base tricycle vehicle with mid engine placement. All wheels powered. Front wheel steering. Operator positioned centrally.

Engine: Kohler, 4 cycle, air cooled, 14 hp @ 3600 rpm, 31.27 cu. in. (512 cc) displacement. Stellite intake and exhaust valve and rotor. Mechanical fuel pump, large capacity dual element air cleaner. 5–1/4 pint oil capacity.

Instrumentation: Ammeter and hour meter.

Gas Tank: 4.25 gallon capacity.

Battery: 12 volt, lead acid, 32 amp hour.

Drive: Hydraulic. Coupling driven variable displacement piston pump with integral auxiliary charge pump to geroller motors which directly drive rear wheels.

Hydraulic Oil Filter: 25 micron, spin on type.

Hydraulic Oil Reservoir: 3 gallon capacity.

Valve: Single section for raising and lowering of implement.

Cylinder: Double acting.

Wheel Bearings: Needle bearing in each wheel motor.

Tires: 22 x 11.00 – 8 two ply pneumatic tubeless. De-mountable and interchangeable. Recommended tire pressure is 4 to 6 PSI.

Speeds (at 3200 RPM): Variable between 0 and 8.5 MPH forward and 0 and 4 MPH reverse.

Seat Adjustment: 4 inches – fore and aft. Additional 1.75 inches forward adjustment available by using front mounting holes.

Dimensions:

Width w/o implement:	57.5 "
Width w/ rake model 08812:	75"
Height:	44"
Length w/o rake:	76"
Net Weight (wet):	750 lb.

Optional Equipment:

Drag Mat	Model No. 08845
Rake	Model No. 08811
Edger Kit	Model No. 08822
Rake Mounting Kit	Model No. 08814
Tooth Rake Kit	Model No. 08812
Weeder Kit	Model No. 08815
Spring Rake Kit	Model No. 08813
Finish Grader	Model No. 08867
Spiker	Model No. 08856
Front Blade Kit	Model No. 08821
Cultivator Kit	Model No. 08818
Prong Rake Attachment	Part No. 42–3960
Hitch Kit	Part No. 20–3900

LOOSE PARTS CHART

Note: Use this chart as a checklist to ensure all parts necessary for assembly have been shipped. If any of these parts are missing, total set-up cannot be completed.

PART DESCRIPTION	QTY.	WHERE USED
Tire & wheel assembly	2	Install on rear motors
Lug nuts	8	
Steering wheel	1	Mount steering wheel
Roll pin 1/4 x 2–1/2 in lg.	1	
Capscrew 5/16 – 18 x 5/8" lg.	2	Secure battery cables to battery
Locknuts 5/16 – 18	2	
Capscrew 1/2 – 13 x 1–1/4" lg.	4	Attach implements to frame
Washer 1/2	4	
Cylinder pin	1	Attach cylinder to implement
Cotter pin	1	
Hair pin cotter	1	
Ignition key	1	
Operator's manual	1	Read before operating machine.
Parts catalog	1	Fill out and return to Toro.
Registration card	1	

Specifications and design subject to change without notice.

SET UP INSTRUCTIONS

INSTALL WHEELS (Fig. 1)

Note: Install the rear wheels to the machine while it is still on the pallet shipping blocks.

1. Mount a wheel to each wheel motor and secure with lug nuts. Tighten lug nuts evenly and gradually in a crisscross manner to 45–55 ft–lb.
2. Remove the banding securing the machine to the pallet.
3. Place a jack under square tube of frame (Fig. 1).

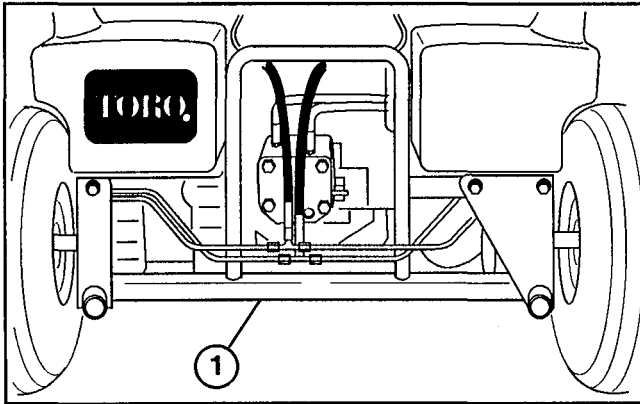

Figure 1
1. Tubular frame

Note: For removal of the shipping blocks, place the jack only under the tubular frame. Do not place jack under the wheel motors, or damage could result.

4. Jack up the machine, remove the shipping blocks and lower the machine onto the rear wheels.

Note: We suggest saving the shipping blocks, as they are the correct height for blocking the unit when changing tires, servicing wheel motors or performing other service work.

INSTALL STEERING WHEEL (Fig. 2)

1. Move front wheel so it points straight ahead.
2. Slide steering wheel onto steering shaft aligning mounting holes.
3. Secure steering wheel in place with roll pin.

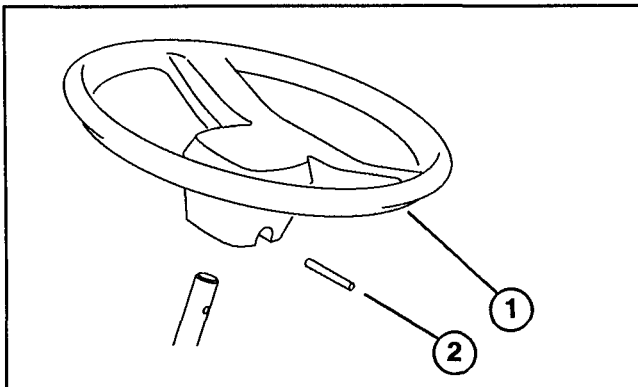

Figure 2
1. Steering wheel
2. Roll pin

PUSH UNIT OFF PALLET (Fig. 3)

1. Rotate by-pass valve 1/2 turn counterclockwise (Fig. 3).

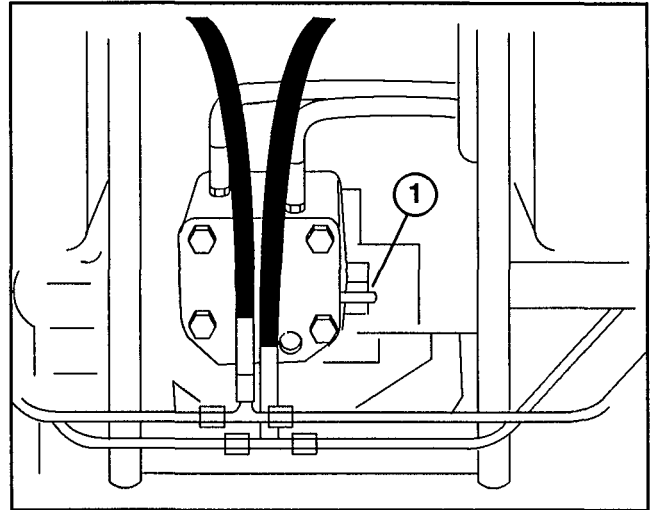

Figure 3
1. By-pass valve

2. Make sure front wheel is straight ahead; then push unit off pallet.
3. Close by-pass valve securely. Do not exceed 5–8 ft–lb torque. Do not start engine when valve is open.

ACTIVATE AND CHARGE BATTERY (Fig. 4)

1. If Battery is not filled with electrolyte or activated, bulk electrolyte with 1.260 specific gravity must be purchased from a local battery supply outlet and added to battery.



CAUTION

Wear safety goggles and rubber gloves when working with electrolyte. Charge the battery in a well ventilated place so gasses produced while charging can dissipate. Since the gasses are explosive, keep open flames and electrical spark away from the battery; do not smoke. Nausea may result if the gasses are inhaled. Unplug charger from electrical outlet before connecting to or disconnecting charger leads from battery posts.

2. Remove filler caps from battery and slowly fill each cell until electrolyte is up to fill line.

SET UP INSTRUCTIONS

3. Replace filler caps and connect a 3 to 4 amp battery charger to the battery posts. Charge the battery at a rate of 3 to 4 amperes for 4 to 8 hours.

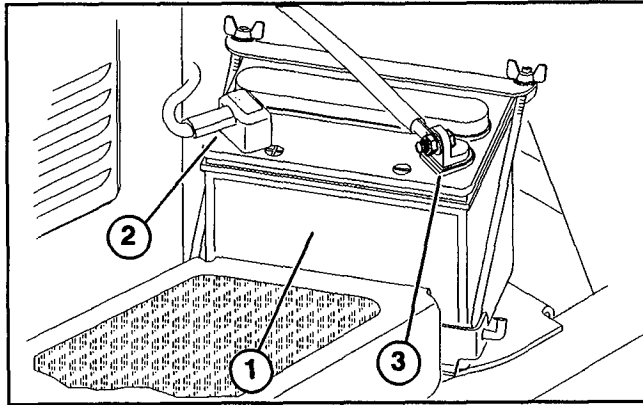

Figure 4

1. Battery
2. Positive (+) battery terminal
3. Negative (-) battery terminal

4. When battery is charged, disconnect charger from electrical outlet and battery posts. Allow battery to sit for 5–10 minutes.

5. Remove filler caps. Slowly add electrolyte to each cell until level is up to fill line. Install filler caps.

IMPORTANT: Do not overfill battery. Electrolyte will overflow onto other parts of the machine and severe corrosion and deterioration will result.

INSTALL BATTERY (Fig. 4)

1. Set the battery in place, with the negative (-) terminal to the outside.
2. Secure the positive cable (red), which is the wire attached to the solenoid under the front shroud, to the positive (+) terminal with a carriage bolt and locknut.



WARNING

Connecting cables to the wrong post could result in personal injury and/or damage to the electrical system. Make sure battery or cables do not interfere or rub on any moving or hot parts.

3. Secure the negative cable (black) to the negative (-) terminal of the battery with a carriage bolt and lock nut.
4. Coat the terminals and mounting fasteners with petroleum jelly to prevent corrosion. Slide the rubber boot over the positive (+) terminal to prevent possible short-out from occurring.
5. Install the battery clamp and secure with rods and wing nuts.

INSTALL REFUSE CONTAINER (Fig. 5)

1. Slide refuse container onto mounting studs on front of fuel tank.

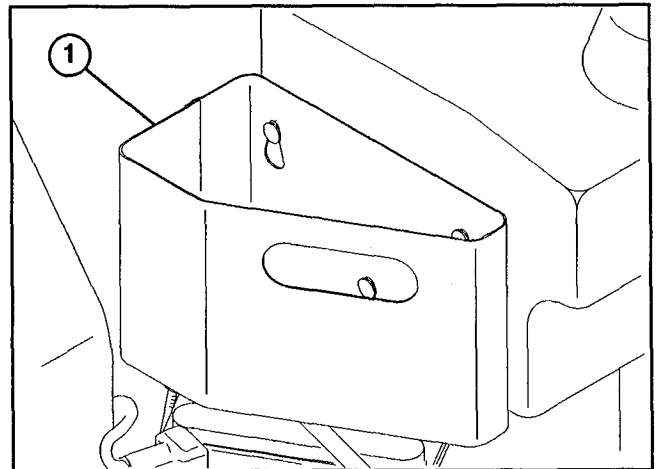

Figure 5

1. Refuse container

BEFORE OPERATING



CAUTION

Before servicing or making adjustments to the machine, stop engine and remove key from the switch.

CHECK CRANKCASE OIL (Fig. 6)

The engine is shipped with oil in the crankcase; however, level of oil must be checked before and after the engine is first started.

Crankcase capacity is approximately 5-1/4 pints.

1. Position machine on a level surface.
2. Remove dipstick and wipe it with a clean rag. Push dipstick down into dipstick tube and make sure it is seated fully. Pull dipstick out and check level of oil.

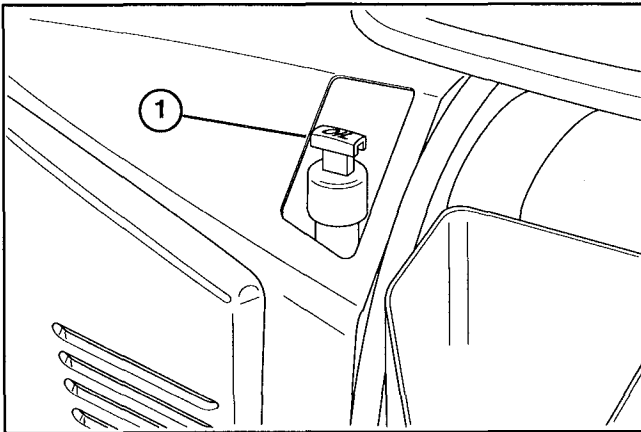

Figure 6
1. Dipstick

3. If oil level is low, add enough oil to raise level to FULL mark on dipstick. Use oil having the API "service classification" SF. Oil viscosity -weight - is selected according to anticipated ambient temperature. Temperature/viscosity recommendations are:

A. Above 32° F (0° C) - Use SAE 30. The use of multi-weight oil above 32° F (0° C) is not recommended due to increased oil consumption and excessive combustion chamber deposits.

B. Below 32° F (0° C) - Use SAE 5W-20 or 5W-30, and if they are not available, 10W-30 or 10W-40 are acceptable substitutes.

IMPORTANT: Check level of oil every 5 operating hours or daily. Change oil after every 25 hours of operation.

FILL FUEL TANK (Fig. 7)

THE TORO COMPANY STRONGLY RECOMMENDS THE USE OF FRESH, CLEAN, UNLEADED REGULAR GRADE GASOLINE IN TORO GASOLINE POWERED PRODUCTS. UNLEADED GASOLINE BURNS CLEANER, EXTENDS ENGINE LIFE, AND PROMOTES GOOD STARTING BY REDUCING THE BUILD-UP OF COMBUSTION CHAMBER DEPOSITS. LEADED GASOLINE CAN BE USED IF UNLEADED IS NOT AVAILABLE.

NOTE: Never Use Methanol, Gasoline Containing Methanol, Gasoline Containing More Than 10% Ethanol, Gasoline Additives, Premium Gasoline Or White Gas Because Engine Fuel System Damage Could Result.

Fuel tank capacity is approximately 4.25 gallons.

1. Clean area around fuel tank cap.
2. Remove fuel tank cap.
3. Fill tank to about one inch below top of tank, (bottom of filler neck). **DO NOT OVERFILL.** Then install cap.
4. Wipe up any fuel that may have spilled to prevent a fire hazard.



DANGER

Because gasoline is flammable, caution must be used when storing or handling it. Do not fill fuel tank while engine is running, hot or when machine is in an enclosed area. Vapors may build up and be ignited by a spark or flame source many feet away. **DO NO SMOKE** while filling the fuel tank to prevent the possibility of an explosion. Always fill fuel tank outside and wipe up any spilled gasoline before starting engine. Use a funnel or spout to prevent spilling gasoline, and fill tank no higher than to bottom of filter screen. **DO NOT OVER FILL.** Store gasoline in a clean safety approved container and keep the cap on the container. Keep gasoline in a cool, well-ventilated place; never in an enclosed area such as a hot storage shed. To assure volatility, do not buy more than a 30 day supply of gasoline. Gasoline is a fuel for internal combustion engines; therefore do not use it for any other purpose. Since many children like the smell of gas, keep it out of their reach because the fumes are explosive and dangerous to inhale.

BEFORE OPERATING

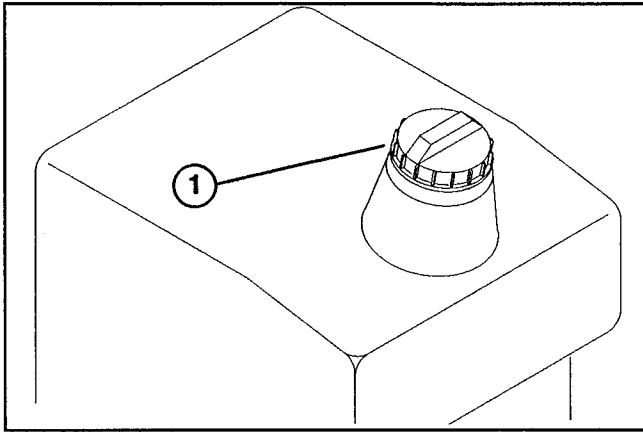

Figure 7
1. Fuel tank cap

CHECK HYDRAULIC SYSTEM (Fig. 8)

The hydraulic system is designed to operate on SAE 10W-30 or 10W-40 SF type motor oil. The machine's 3 gallon reservoir is filled at the factory with oil. However, check level of oil before engine is first started and daily thereafter.

1. Remove cap from hydraulic oil reservoir.
2. Check level of oil in reservoir. Oil level should be up to top of cone point on tank screen.

3. If oil level is low, add SAE 10W-30 or 10W-40 SF type motor oil until level is up to top of cone point on tank screen. **DO NOT OVERFILL.**

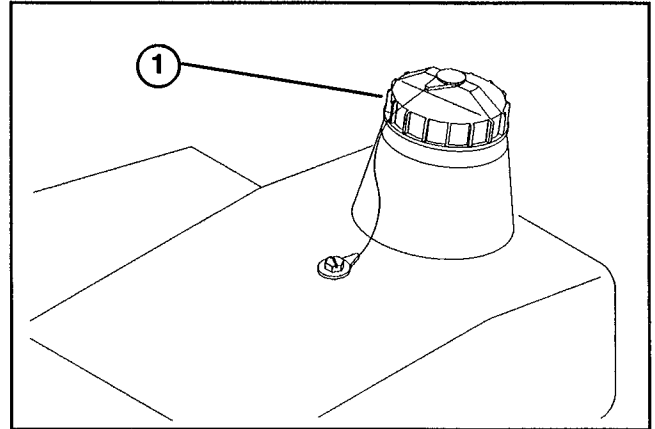

Figure 8
1. Oil reservoir cap

4. Install reservoir cap.

IMPORTANT: To prevent system contamination, clean top of hydraulic oil containers before puncturing. Assure pour spout and funnel are clean.

CHECK TIRE PRESSURE

Check tire pressure before operating machine. Correct air pressure in front and rear tires is 4-6 psi.

KNOW YOUR CONTROLS

Traction and Stopping Pedal (Fig. 9–10) – Traction pedal has three functions: one, to make the machine move forward, two, to move it backward and three, to stop machine. Using the heel and toe of the right foot, depress top of pedal to move forward and bottom of pedal to move backward or to assist in stopping when moving forward. Also, allow pedal to move or move it to neutral position to stop machine. **For operator comfort, do not rest heel of foot on reverse when operating forward (Fig. 10).**

Ground speed is proportionate to how far traction pedal is depressed. For maximum ground speed, pedal must be fully depressed while throttle is in FAST position. To get maximum power or when ascending a hill, have throttle in FAST position while depressing pedal slightly to keep engine rpm high. When engine rpm begins to decrease, release pedal slightly to allow rpm to increase.

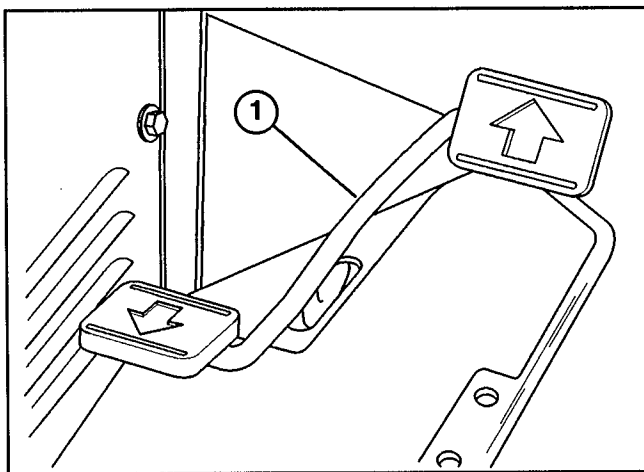

Figure 9

1. Traction & Stopping Pedal

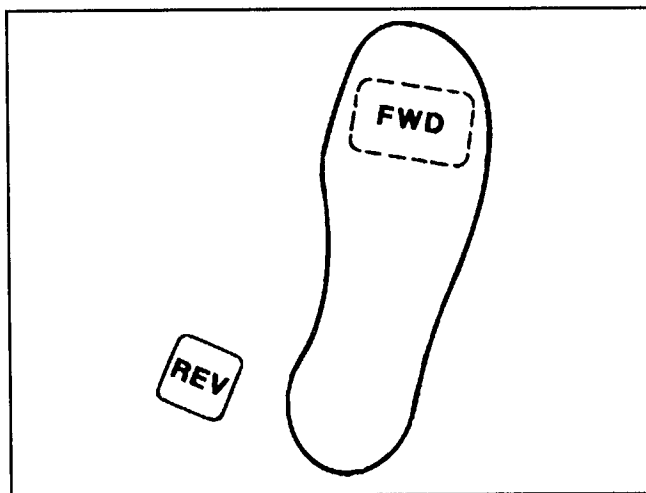

Figure 10

IMPORTANT: For maximum pulling power, throttle should be in “Fast” position, and traction pedal just barely depressed.



CAUTION

Use the maximum ground speed **ONLY** when driving from one area to another. Maximum speed is not recommended when using an attached or towed implement.

IMPORTANT: The SAND PRO must not be operated in reverse with the implement in the down (operating) position, or the implement could be severely damaged.

Ignition Switch (Fig. 11) – The ignition switch, used to start and stop the engine, has three positions: OFF, RUN and START. Rotate key clockwise — START position — to engage starter motor. Release key when engine starts. The key will move automatically to the ON position. To shut engine off, rotate key counterclockwise to OFF position.

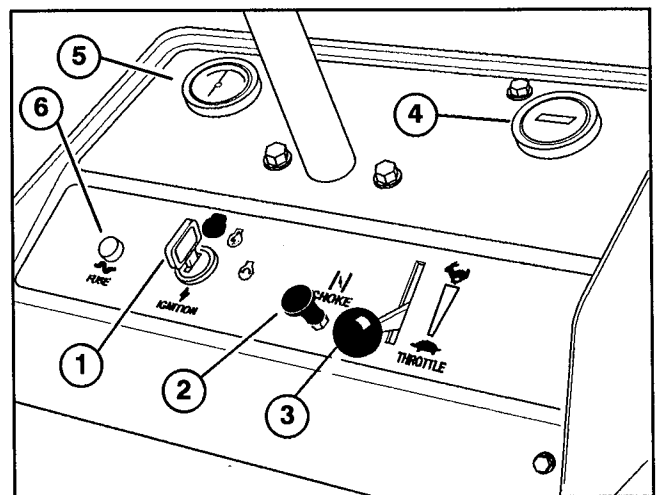

Figure 11

- | | |
|---------------------|---------------|
| 1. Ignition switch | 4. Hour meter |
| 2. Choke control | 5. Ammeter |
| 3. Throttle control | 6. Fuse |

Choke Control (Fig. 11) – To start a cold engine, close carburetor choke by pulling choke control out to ON position. After engine starts, regulate choke to keep engine running smoothly. As soon as possible, open the choke by pushing it downward to the OFF position. A warm engine requires little or no choking.

Throttle Control (Fig. 11) – Lever connects to and operates throttle linkage to carburetor. Control has two positions: SLOW and FAST. Engine speed can be varied between the two settings.

Note: The engine cannot be stopped by the throttle control.

Hour Meter (Fig. 11) – Indicates the total hours of machine operation. The Hour Meter starts to function whenever the key switch is rotated to “ON” position.

KNOW YOUR CONTROLS

Ammeter (Fig. 11) – The ammeter indicates the rate of battery charge or discharge.

Note: During normal operation, there will usually be slight ammeter needle movement to positive side.

Lift Lever (Fig. 12) – To raise the implement, pull the lever up; to lower implement, push the lever down. When the desired position is attained, release the lever and it will return to neutral.

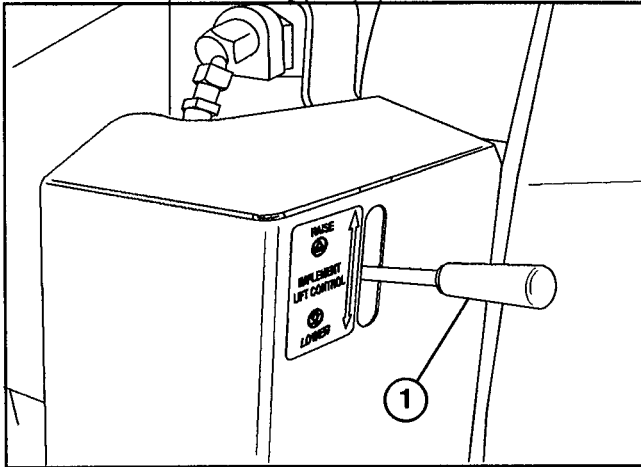

Figure 12
1. Lift lever

NOTE: The SAND PRO has a double-acting lift cylinder. Down pressure can be applied to the implement for certain operating conditions.

Fuel Shut-Off Valve (Fig. 13) – Close fuel shut-off valve when storing machine.

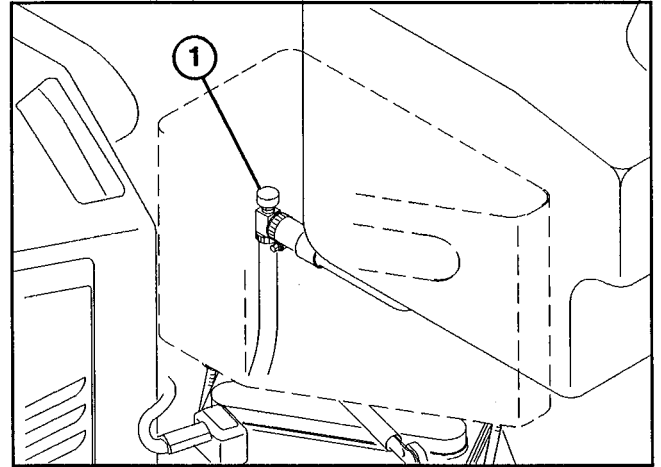

Figure 13
1. Fuel shut-off valve

OPERATING INSTRUCTIONS

STARTING/STOPPING ENGINE

1. Remove foot from traction pedal and make sure pedal is in neutral position.
2. Pull choke lever out to ON position – when starting a cold engine – and throttle lever to SLOW position.
3. Insert key into ignition switch and rotate it clockwise to start the engine. Release key when engine starts. Regulate the choke to keep engine running smoothly.

IMPORTANT: To prevent overheating of the starter motor, do not engage starter longer than 10 seconds. After 10 seconds of continuous cranking, wait 60 seconds before engaging starter motor again.

4. When engine is started for the first time, or after overhaul of the engine, operate the machine in forward and reverse for one to two minutes. Also operate the lift lever to be sure of proper operation of all parts.



CAUTION

Shut engine off and wait for all moving parts to stop before checking for oil leaks, loose parts and other malfunctions.

5. To stop engine, move throttle control to SLOW position and rotate ignition key to OFF. Remove key from switch to prevent accidental starting.

6. Close fuel shut off valve before storing machine.

CHECK INTERLOCK SYSTEM OPERATION

The purpose of the interlock system is to prevent the engine from cranking or starting unless the traction pedal is in "NEUTRAL".

1. Check interlock operation in a wide open area free of debris and bystanders. Stop engine.
2. Sit on the seat. Depress traction pedal in forward and reverse directions, while trying to start the engine. If engine cranks there may be a malfunction in the interlock system. Repair immediately. If engine does not crank, system is operating correctly.

OPERATING INSTRUCTIONS



CAUTION

THE INTERLOCK SWITCH IS FOR THE OPERATOR'S PROTECTION, SO DO NOT DISCONNECT IT. CHECK OPERATION OF THE SWITCH DAILY TO ASSURE INTERLOCK SYSTEM IS OPERATING. IF THE SWITCH IS DEFECTIVE, REPLACE IT BEFORE OPERATING. REGARDLESS IF SWITCH IS OPERATING PROPERLY OR NOT, REPLACE IT EVERY TWO YEARS TO ASSURE MAXIMUM SAFETY. DO NOT RELY ENTIRELY ON SAFETY SWITCHES – USE COMMON SENSE!

TOWING SAND PRO (Fig. 14)

In case of emergency, the SAND PRO can be towed for a short distance. However, Toro does not recommend this as a standard procedure.

IMPORTANT: Do not tow the machine faster than 2–3 mph because drive system may be damaged. If machine must be moved a considerable distance, transport it on a truck or trailer.

1. Reach under rear of machine and rotate by-pass valve on pump counterclockwise until it is fully open.
2. Before starting engine, close by-pass valve securely by rotating it clockwise. Do not exceed 5–8 ft-lb torque. Do not start engine when valve is open.

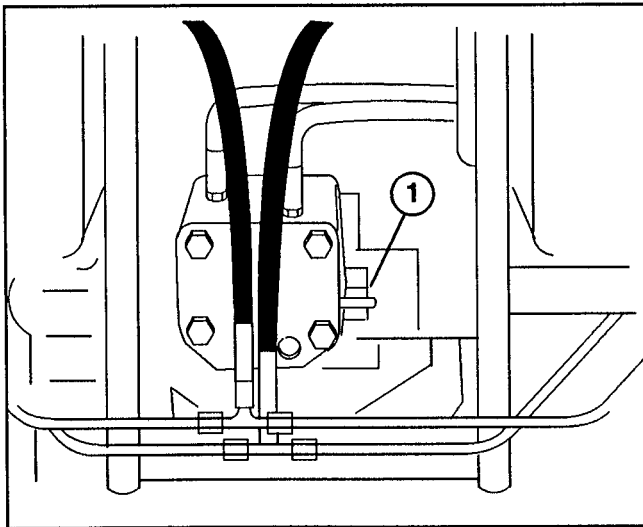

Figure 14
1. By-pass valve

BREAK-IN PERIOD

1. Only 8 hours operating time is required for SAND PRO break-in period.

2. Since the first hours of operation are critical to future dependability of the machine, monitor its functions and performance closely so that minor difficulties, which could lead to major problems, are noted and can be corrected. Inspect SAND PRO frequently during break-in for signs of oil leakage, loose fasteners, or any other malfunction.

OPERATING CHARACTERISTICS

Practice driving the SAND PRO because its operating characteristics are different than some utility vehicles. Two points to consider when operating the vehicle are transmission and engine speed.

To maintain somewhat constant engine rpm, depress traction pedal slowly. This allows the engine to keep up with ground speed of the vehicle. By contrast, pushing down quickly on the traction pedal will reduce engine rpm and, as a result, there will not be enough torque–power–to move the vehicle. Therefore, to transfer maximum power to the rear wheels, move throttle to FAST and slightly depress traction pedal. By comparison, maximum ground speed with no load results when throttle is in FAST position and traction pedal is slowly but fully depressed. In summary, always keep engine rpm high enough to deliver maximum torque–power–to the rear wheels.



CAUTION

USING THE MACHINE DEMANDS ATTENTION. TO PREVENT TIPPING OR LOSS OF CONTROL, USE CARE WHEN ENTERING AND LEAVING SAND TRAPS. USE EXTREME CAUTION AROUND DITCHES, CREEKS OR OTHER HAZARDS. USE CAUTION WHEN OPERATING MACHINE ON A STEEP SLOPE. REDUCE SPEED WHEN MAKING SHARP TURNS OR WHEN TURNING ON HILLSIDES. AVOID SUDDEN STOPS AND STARTS. DO NOT GO FROM REVERSE TO FULL FORWARD WITHOUT FIRST COMING TO A COMPLETE STOP.

INSPECTION AND CLEAN-UP

At the completion of operation, thoroughly wash the machine with a garden hose – without a nozzle – so excessive water pressure will not cause contamination and damage to seals and bearings.

Make sure cooling fins and area around engine cooling air intake are kept free of debris. After cleaning, it is recommended the machine be inspected for possible hydraulic fluid leaks, damage or wear to hydraulic and mechanical components.

DAILY MAINTENANCE CHECKLIST

Daily Maintenance: (duplicate this page for routine use)

Maintenance Check Item ▼	Daily Maintenance Check For Week Of _____						
	MON	TUES	WED	THURS	FRI	SAT	SUN
✓ Safety Interlock Operation							
✓ Steering Operation							
✓ Engine Oil Level							
✓ Air Filter/Pre-Cleaner Condition							
Clean Engine Cooling Fins							
✓ Unusual Engine Noises							
✓ Unusual Operating Noises							
✓ Hydraulic System Oil Level							
✓ Hydraulic Hoses for Damage							
✓ Fluid Leaks							
✓ Fuel Level							
✓ Tire Pressure							
✓ Instrument Operation							
Touch-up Damaged Paint							

Notation for areas of concern: Inspection performed by _____

Item	Date	Information
1		
2		
3		
4		
5		
6		
7		
8		

Check proper section of Operator's Manual for fluid specifications

MAINTENANCE



CAUTION

Before servicing or making adjustments to the machine, stop engine and remove key from the switch.

LUBRICATION (Fig. 15)

The steering shaft grease fitting must be lubricated every 100 hours with No. 2 General Purpose Lithium Base Grease.

1. Remove (4) screws securing front panel to frame (Fig. 15). Locate grease fitting thru opening in frame.

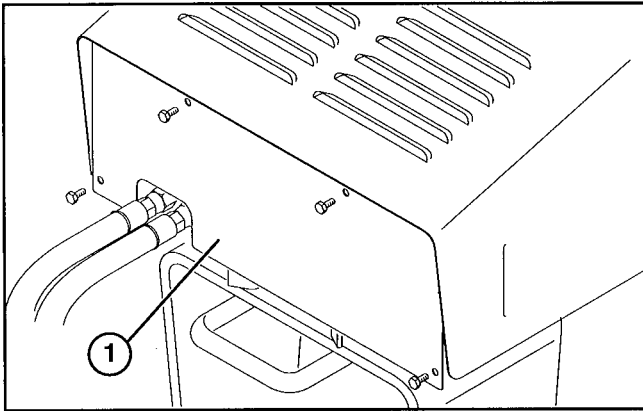

Figure 15
1. Front panel

NOTE: We do not recommend lubricating the steering chain unless it becomes stiff because of rust. If the chain rusts, it may be lubricated lightly with a DRY-TYPE LUBRICANT.

CHANGING CRANKCASE OIL

For new engines, change oil after first 5 operating hours. Thereafter, under normal conditions, change oil after every 25 hours of engine operation. However, an engine operated in dusty or dirty conditions requires more frequent oil changes. If possible, run engine just before changing oil. Warm oil flows more freely and carries more contaminants than cold oil.

1. Place an oil drain pan below the drain plug on bottom of crankcase. Clean area around drain plug.
2. Remove drain plug and allow oil to flow into drain pan. After oil is drained, reinstall oil drain plug.
3. Remove dipstick / filler cap and pour approximately 5–1/4 pints of oil having the API "service classification" SF into the filler neck. Oil viscosity – weight – is selected according to anticipated ambient temperature. Temperature/ viscosity recommendations are:

A. Above 32° F (0°C) – Use SAE 30. The use of multi-weight oil above 32° F (0°C) is not recommended due to increased oil consumption and excessive combustion chamber deposits.

B. Below 32° F (0° C) – Use SAE 5W–20 or 5W–30, and if they are not available, 10W–30 or 10W–40 are acceptable substitutes.

4. Check oil and make sure level is up to the FULL mark on dipstick. Add more oil if level is low; however, DO NOT OVERFILL.
5. Dispose of oil properly.

SERVICING AIR CLEANER (Fig. 16)

The foam precleaner must be cleaned and re-oiled after every 25 hours engine operation if engine is operated in clean air conditions. However, air cleaner must be cleaned every few hours if operating conditions are extremely dusty or sandy.

1. Remove engine shield mounting screws and remove shield.
2. Remove lock nut and air cleaner cover.

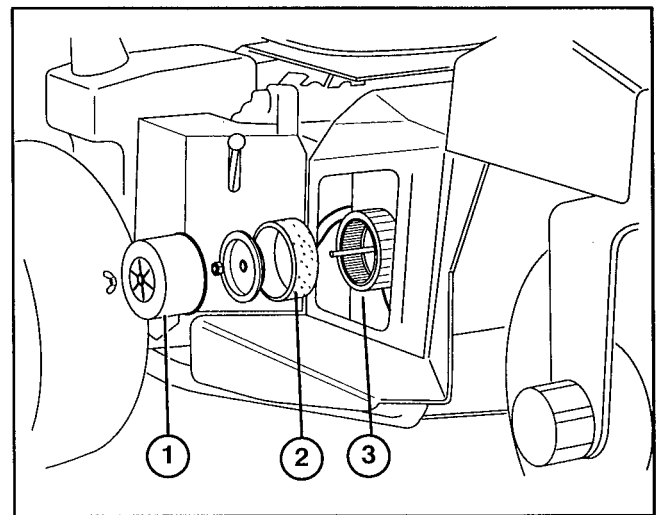

Figure 16

1. Air cleaner cover
2. Foam precleaner
3. Paper cartridge

3. Remove foam precleaner by sliding it off the paper element.
4. **A.** Wash foam precleaner in detergent and warm water.
B. Wrap foam precleaner in cloth and squeeze dry. Do not wring precleaner.
C. Saturate foam pre-cleaner in engine oil. Squeeze to remove excess oil.
5. Reinstall on paper cartridge.

Inspect paper element every 100 hours of operation and replace when dirty or damaged. Do not wash paper element or do not clean with compressed air as damage will occur.

MAINTENANCE

Note: With air cleaner disassembled, check air cleaner components for damage. Replace if necessary. Make sure rubber breather tube in base plate is securely in place or severe engine damage may occur.

6. Reinstall element with precleaner, element cover seal, air cleaner element cover, nut, air cleaner cover and lock nut.
7. Tighten lock nut 1/2 to 1 turn after nut contacts cover. Do not overtighten.
8. Reinstall engine shield.

ADJUSTING CARBURETOR (Fig. 17)

Lack of power accompanied by black sooty exhaust smoke is usually caused by a rich carburetor setting. Since a dirty air cleaner element causes the same conditions, check it before adjusting carburetor.

High RPM Setting – 3200 ± 100

Low RPM Setting – 1800 ± 100

IMPORTANT: Check to make sure the choke is operating correctly before the carburetor is adjusted.

1. Remove engine shield mounting screws and remove shield.
2. Main fuel screw – Close screw by gently rotating it clockwise.

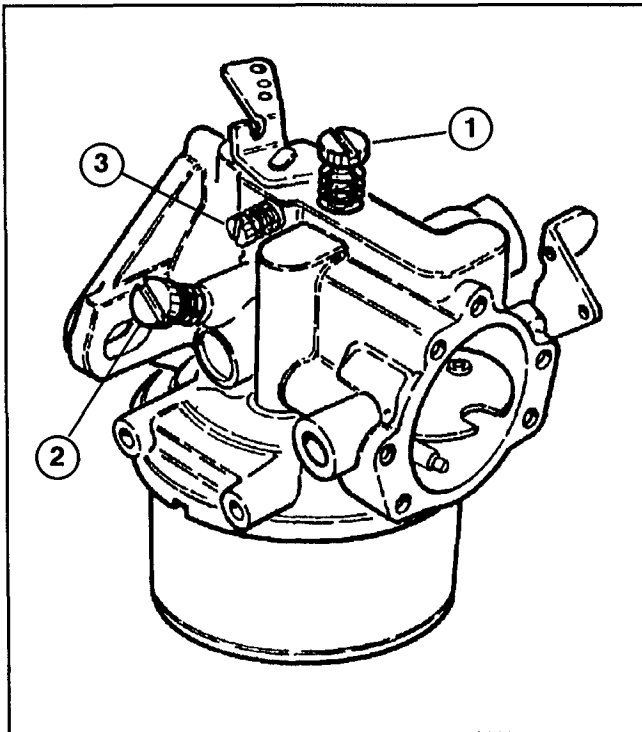

Figure 17

1. Main fuel screw
2. Idle fuel adjusting screw
3. Idle speed screw

IMPORTANT: Do not close the screw too tightly because the screw will likely be damaged.

3. Rotate – open the main fuel screw 1–1/2 turns counterclockwise.
4. Idle fuel adjusting screw – Close screw by gently rotating it clockwise. Open screw by rotating it 1–1/4 turns counterclockwise.



WARNING

Engine must be running so final adjustment of the carburetor can be performed. To guard against possible personal injury, keep hands, feet, face and other parts of the body away from the muffler, other hot parts of the engine, and other moving or rotating parts of the engine.

IMPORTANT: Do not close the screw too tightly because the screw will likely be damaged.

Note: These settings are approximate; however, the settings will allow engine to be started so carburetor can be fine tuned – steps 4–7.

5. Start engine and let it run for 5–10 minutes at half throttle to warm up. Engine must be warm before making final adjustments.
6. Move throttle to FAST position. Turn main fuel screw in until speed decreases and note position of screw. Now turn screw out – the engine speed may first increase, then it will decrease as screw is turned. Note the position of screw when engine speed starts to decrease. Set the screw at the midpoint of the two positions noted.
7. To adjust idle fuel adjusting screw, follow same procedure as for main fuel but move throttle to IDLE after 5–10 minute warm up and make adjustment.
8. Idle Speed Setting – Run engine at half throttle for 5–10 minutes to warm up. Move throttle to IDLE and set engine speed to 1800 RPM by turning the idle speed adjusting screw clockwise or counterclockwise.
9. Reinstall engine shield.

CHECKING AND REPLACING SPARK PLUG (Fig. 18)

Since air gap between center and side electrodes increases gradually during normal engine operation, check condition of electrodes at 100 hour intervals. The correct spark plug for the engine is Champion RJ–19 LM or equivalent. Set air gap at .025 in.

1. Remove engine shield mounting screws and remove shield.

MAINTENANCE

2. Clean area around spark plug so dirt does not fall into cylinder when plug is removed.
3. Pull wire off spark plug and remove plug from cylinder head.
4. Check condition of center and side electrodes to determine operating temperature of engine.
 - A. Light brown insulator tip indicates correct spark plug and heat range.
 - B. Black or oily insulator tip indicates an excessively rich fuel mixture, possibly caused by a dirty air cleaner element or a carburetor that is set too rich.
 - C. Light gray or blistered—white insulator indicates overheating caused by a lean carburetor setting or incorrect spark plug (heat range too high).

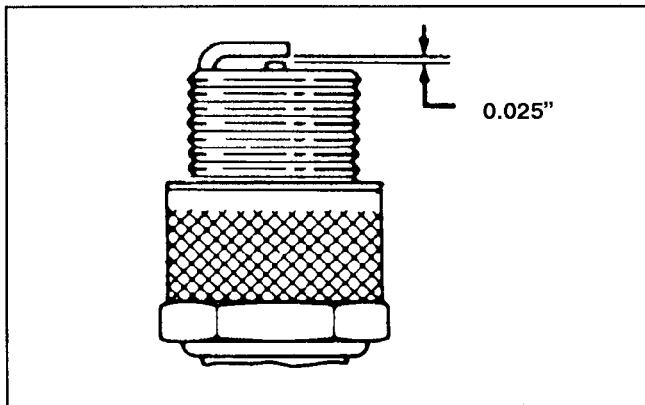

Figure 18

IMPORTANT: A cracked, fouled or dirty spark plug must be replaced. Do not sandblast, scrape or clean electrodes by using a wire brush because grit may release from the plug and enter combustion chamber resulting in engine damage.

5. After setting air gap at .025", install spark plug in cylinder head. Tighten the plug to 10–15 ft–lb. Push wire onto spark plug.
6. Reinstall engine shield.

CLEANING CYLINDER HEAD FINS

To avoid overheating and possible engine damage, cooling fins on cylinder head must be kept clean.

CHANGING HYDRAULIC SYSTEM OIL AND FILTER (Fig. 19)

The hydraulic system filter must be changed initially, after the first five hours of operation, and thereafter every 400 hours of operation or yearly, whichever comes first. Use a genuine Toro oil filter for replacement. The hydraulic oil must be changed every 400 hours of operation or yearly, whichever comes first.

1. Park the machine on a level surface and turn the engine off.
2. Pivot seat upward.
3. Disconnect hose from bottom fitting of reservoir and let oil flow into drain pan. Reinstall and tighten hose when oil stops draining.
4. Clean the area around the hydraulic oil filter. Remove filter from the bottom of the filter housing and allow the oil to flow into a drain pan. Use bottom type filter wrench. Dispose of the oil filter properly.

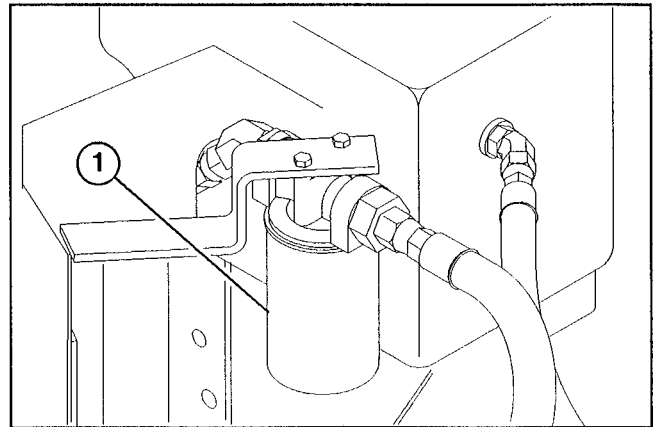

Figure 19
1. Hydraulic filter

5. Apply a film of oil on the filter gasket. Install filter by hand until gasket contacts mounting head; then tighten filter an additional three–fourths turn.
6. Fill the reservoir to proper level, refer to Check Hydraulic System.
7. Place all controls in neutral or disengaged position and start engine. Run engine at lowest possible RPM to purge the system of air.
8. Run engine until lift cylinder extends and retracts and forward and reverse wheel motion is achieved.
9. Stop the engine and check the oil level in reservoir, add oil if necessary.
10. Check all connections for leaks.
11. Lower seat.
12. Dispose of oil properly.

MAINTENANCE

CHECKING HYDRAULIC LINES AND HOSES

Visually inspect hydraulic lines and hoses daily for leaks, kinked lines, loose mounting supports, wear, loose fittings, weather deterioration and chemical deterioration. Make all necessary repairs before operating.



WARNING

Keep body and hands away from pin hole leaks or nozzles that eject high pressure hydraulic fluid. Use cardboard or paper to find hydraulic leaks. Hydraulic fluid escaping under pressure can penetrate skin and cause injury. Fluid accidentally injected into the skin must be surgically removed within a few hours by a doctor familiar with this form of injury or gangrene may result.

CHARGING HYDRAULIC SYSTEM (Fig. 20)

Whenever a hydraulic component is repaired or replaced hydraulic oil filter should be changed and hydraulic system charged.

IMPORTANT: Make sure hydraulic reservoir and filter are filled with oil at all times when charging hydraulic system.

1. Park the machine on a level surface and turn the engine off.
2. Pivot seat upward.
3. Loosen (2) capscrews and nuts securing leaf springs to pump late until bearing drops away from cam on lever allowing pump shaft freedom to rotate during start-up.
4. Raise one rear wheel off floor and place support blocks under frame.
5. Start engine and set throttle to allow engine to run at approximately 1500 rpm.

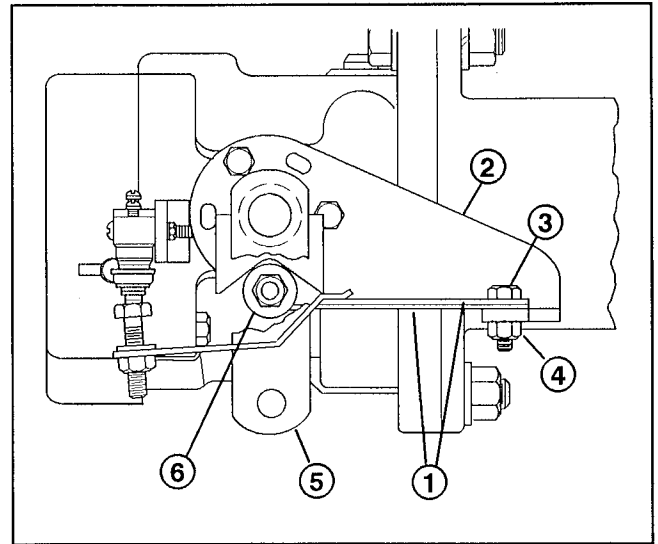

Figure 20

- | | |
|-----------------|---------------|
| 1. Leaf springs | 4. Nut |
| 2. Pump plate | 5. Pump lever |
| 3. Capscrew | 6. Bearing |

6. Actuate the lift valve lever until the lift cylinder rod moves in and out several times. If cylinder rod does not move after 10–15 seconds or pump emits abnormal sounds, shut the engine off immediately and determine cause or problem. Inspect for the following:

- A. Loose filter or suction lines.
- B. Loose or faulty clutch on pump.
- C. Blocked suction line.
- D. Faulty charge relief valve.
- E. Faulty charge pump.

If cylinder moves in 10–15 seconds, proceed to step 7.

Note: A hydrostatic transmission service manual (bulletin No. 9646) and a repair manual (bulletin No. 9659) can be obtained from:

**Sundstrand Corporation
2800 East 13th Street
Ames, Iowa 50010**

7. Operate the traction pedal in forward and reverse directions. Wheel off floor should rotate in the proper direction. If wheel rotates in wrong direction, stop engine, remove lines from rear of pump and reverse the locations. If wheel rotates in proper direction, stop engine and tighten capscrews and nuts securing leaf springs. Adjust traction neutral position: refer to Adjusting For Neutral Position In Traction Drive, page 19.
8. Check adjustment of traction interlock switch: refer to Adjusting Traction Interlock Switch, page 20.
9. Lower seat.

MAINTENANCE

ADJUSTING STEERING CHAIN (Fig. 21)

1. Place the front wheel in the straight ahead position.
2. Adjust the locknuts until the chain is snug on both sides of sprocket.
3. Turn the steering wheel full left and full right to be sure the chain does not bind or hang up in either direction. Readjust as required.

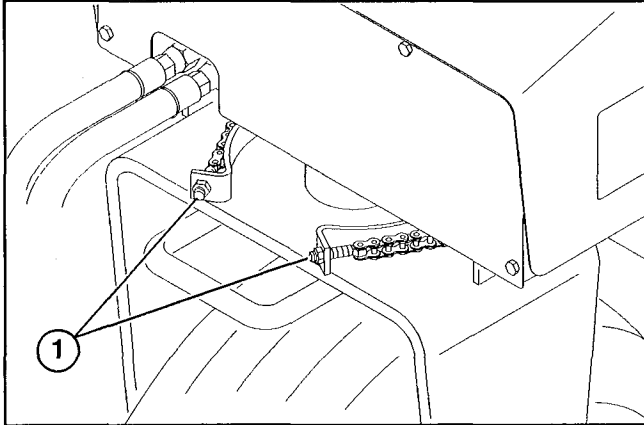

Figure 21
1. Adjusting nuts

Since the chain and sprocket are subjected to sand thrown up by the front tire, inspect them frequently for wear. If either the chain or sprocket is worn beyond acceptable limits, BOTH should be replaced.

REPLACING FUEL FILTER (Fig. 22)

An in-line filter is incorporated into the fuel line. Replace filter every 800 hours. Use the following procedures when replacement becomes necessary:

1. Close fuel shut-off valve.
2. Clamp both fuel lines that connect to the fuel filter so gasoline cannot drain when lines are removed.

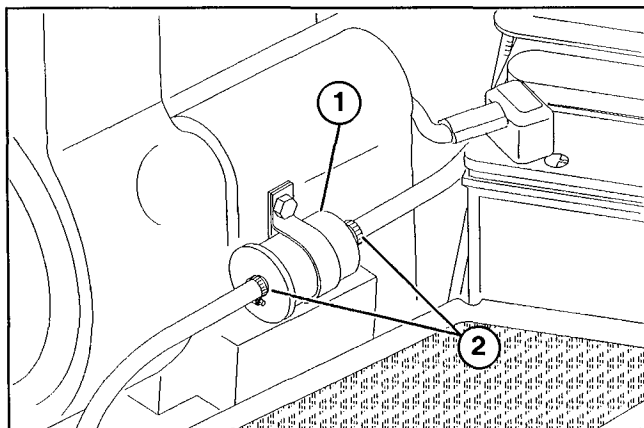

Figure 22
1. Fuel Filter
2. Hose Clamps

3. Loosen the hose clamps at both ends of the filter and pull fuel lines off filter.

4. Slide hose clamps onto ends of fuel lines. Push fuel lines onto fuel filter and secure them with hose clamps. Be sure arrow on side of filter points toward the carburetor.



CAUTION

Since gasoline is highly flammable, drain it outdoors and make sure engine is cool to prevent a potential fire hazard. Wipe up any gasoline that may have spilled. Do not drain gasoline near any open flame or where gasoline fumes may be ignited by a spark. Do not smoke a cigar, cigarette, or a pipe when handling gasoline.

ADJUSTING TRACTION DRIVE FOR NEUTRAL (Fig. 23)

If the machine "creeps" when the traction pedal is in the neutral position, the leaf spring must be adjusted.

1. Park the machine on a level surface and turn the engine off.
2. Pivot seat upward
3. Raise one rear wheel off floor and place support blocks under frame.
4. Start engine, move throttle to SLOW and check wheel that is off floor; it must not be rotating. If wheel is rotating forward, loosen capscrews and lightly tap bottom of pump plate counterclockwise. By contrast, tap plate clockwise if wheel is rotating backward. When wheel stops rotating, tighten capscrews holding pump plate against side of pump. Verify the adjustment the adjustment in SLOW and FAST position.

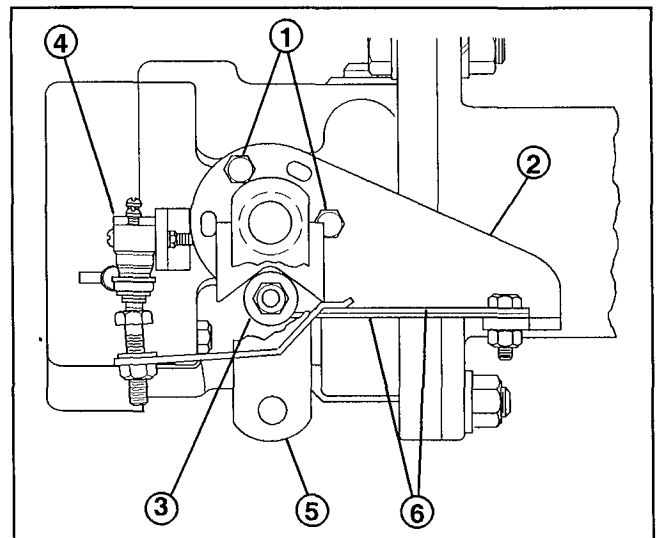

Figure 23

- | | |
|---------------|---------------------|
| 1. Capscrews | 4. Interlock switch |
| 2. Pump plate | 5. Pump lever |
| 3. Bearing | 6. Leaf springs |

MAINTENANCE

5. Should the wheel continue to rotate, check for the following:

- A. Ball bearing is loose or worn out.
- B. Plunger on interlock switch is sticking.
- C. Loose or missing fasteners.
- D. Roll pin mounting pump lever to pump shaft is worn.
- E. Pump lever loose on control shaft. (Apply loctite RC 680 to shaft).
- F. Weak or damaged leaf springs. Replace.
- G. Internal pump component malfunction.

6. Lower seat.

ADJUSTING TRACTION INTERLOCK SWITCH (Fig. 23)

1. Adjust transmission for neutral; refer to Adjusting Traction Drive For Neutral, page 19.
2. Activate the pump lever to assure all parts are operating freely and seated properly.
3. Rotate switch adjusting screw until there is a gap between head of screw and switch button.
4. Rotate adjusting screw until it contacts the switch button. Continue to rotate the screw until the circuit is completed (switch "clicks"). After the switch clicks, rotate the adjusting screw an additional 1/2 turn.
5. Check for proper operation.

ADJUSTING PEDAL FOR REVERSE (Fig. 24)

The pedal must be adjusted for reverse if jam nuts on control rod are loosened or if pedal is removed.

1. Park the machine on a level surface and turn the engine off.
2. Make sure pump is in neutral.
3. Loosen jam nuts on control rod.

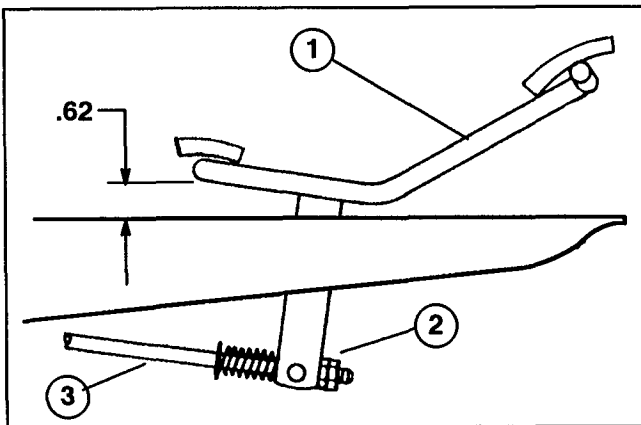

Figure 24

1. Pedal 2. Jam nuts 3. Control rod

4. Press down on rear of pedal until there is 5/8" between pedal and footrest.

5. Tighten jam nuts.

BATTERY STORAGE

If the machine will be stored for more than 30 days, remove the battery and charge it fully. Either store it on the shelf on the machine. Leave the cables disconnected if stored on the machine. Store the battery in a cool atmosphere to avoid quick deterioration of the charge in the battery. To prevent battery from freezing, make sure it is fully charged. The specific gravity of a fully charged battery is 1.250.

BATTERY CARE

1. Battery electrolyte level must be properly maintained and the top of the battery kept clean. If the machine is stored in a location where temperatures are extremely high, the battery will run down more rapidly than if the machine is stored in a location where temperatures are cool.



CAUTION

Wear safety goggles and rubber gloves when working with electrolyte. Charge the battery in a well ventilated place so gasses produced while charging can dissipate. Since the gases are explosive, keep open flames and electrical spark away from the battery; do not smoke. Nausea may result if the gases are inhaled. Unplug charger from electrical outlet before connecting to or disconnecting charger leads from battery posts.

2. Keep top of battery clean by washing periodically with a brush dipped in ammonia or bicarbonate of soda solution. Flush the top surface with water after cleaning. Do not remove the fill cap while cleaning.
3. Battery cables must be tight on terminals to provide good electrical contact.



WARNING

Connecting cables to the wrong post could result in personal injury and/or damage to the electrical system.

4. If corrosion occurs at terminals, disconnect cables, negative (-) cable first and scrape clamps and terminals separately. Reconnect cables, positive (+) cable first and coat terminals with petroleum jelly.
5. Check the electrolyte level every 25 operating hours or, if machine is in storage, every 30 days.
6. Maintain cell level with distilled or demineralized water. Do not fill cells above the fill line.

HYDRAULIC SCHEMATIC

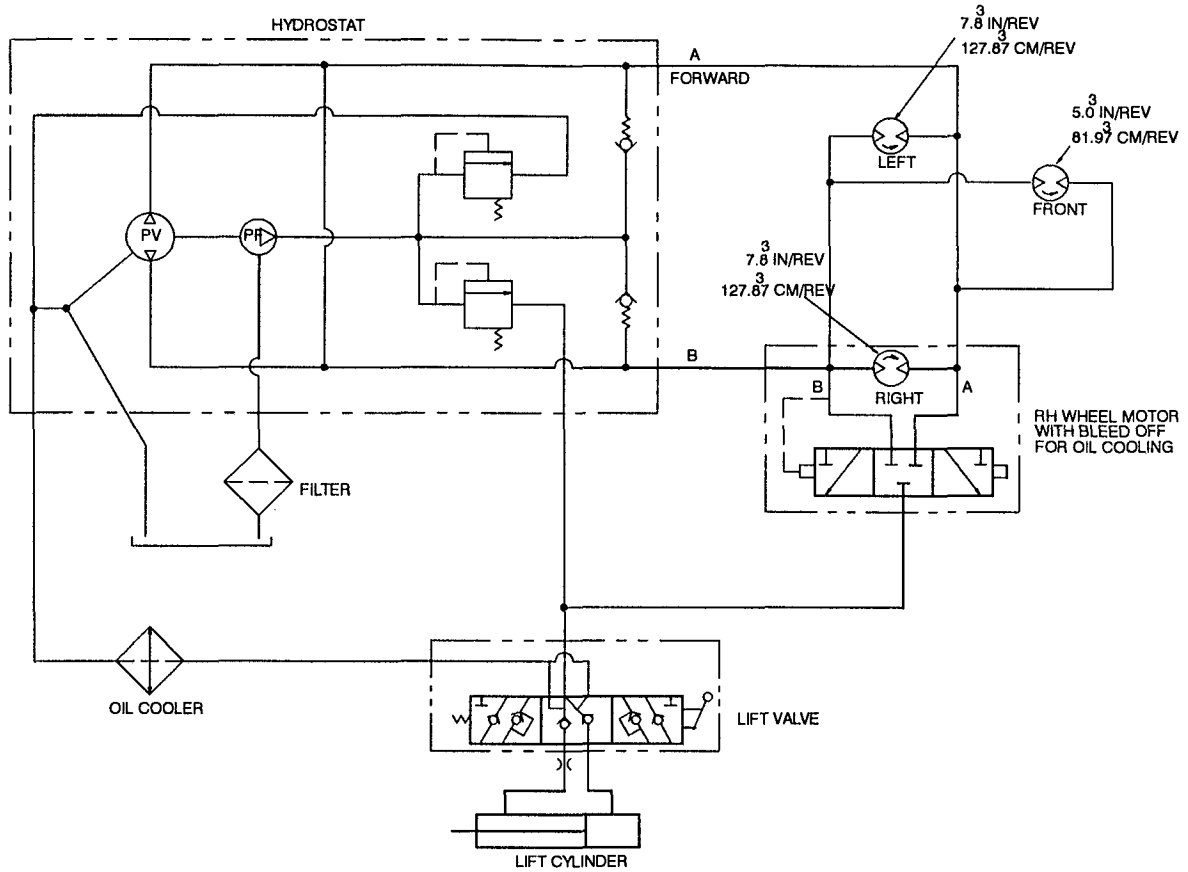

ELECTRICAL SCHEMATIC

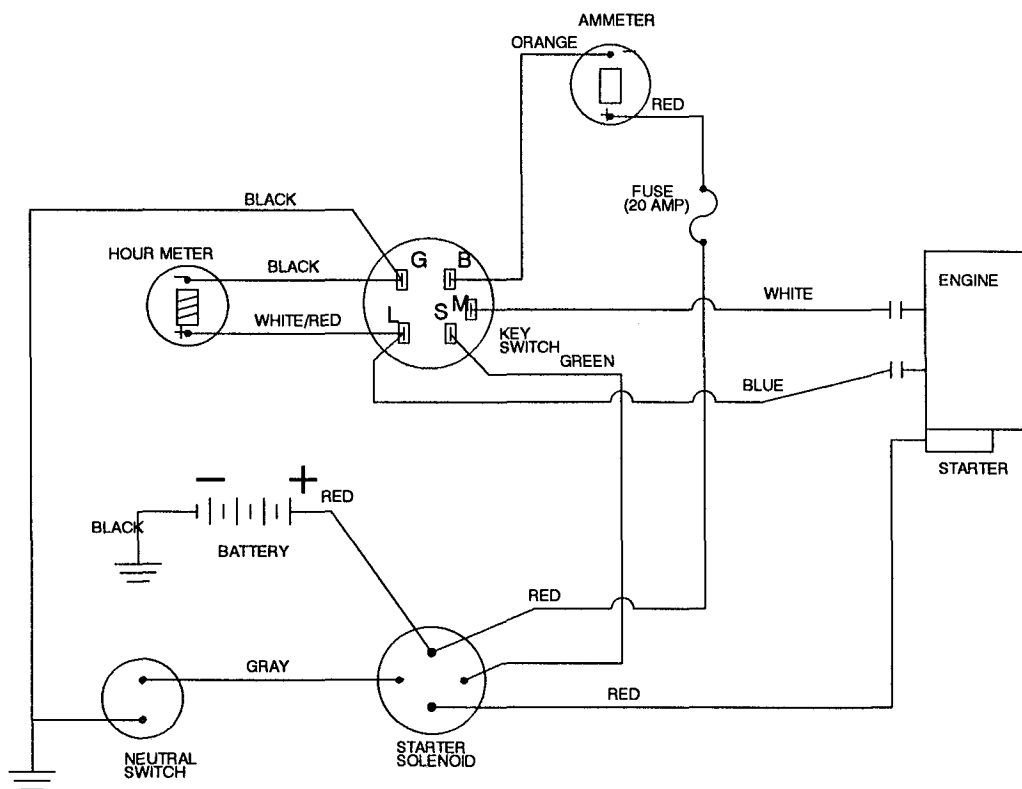

MAINTENANCE SCHEDULE

Minimum Recommended Maintenance Intervals

Maintenance Procedure	Maintenance Interval & Service			
Check Battery Fluid Level	Every 25hrs	Every 100hrs	Every 400hrs	Every 800hrs
Check Battery Cable Connections				
† Change Engine Oil				
Clean Air Filter Foam Pre-cleaner				
Inspect Spark Plug				
Inspect Air Filter Paper Element				
Lube Steering Shaft Grease Fitting				
Check Steering Chain Adjustment				
† Torque Wheel Lug Nuts				
Change Hydraulic Oil				
† Replace Hydraulic Oil Filter				
Clean and Lubricate Starter Motor				
Decarbon Combustion Chamber				
Adjust Valves and Torque Head				
Check Engine RPM (idle and full throttle)				
Replace Fuel Filter				
Drain and Clean Fuel Tank				
† Initial break in at 5 hours				
Replace Moving Hoses	Annual Recommendations:			
Replace Traction Safety Switch	Items listed are recommended every 1500 hours or 2 years, whichever occurs first.			

IDENTIFICATION AND ORDERING

MODEL AND SERIAL NUMBERS

The SAND PRO 3000 has two identification numbers: a model number and a serial number. These numbers are stamped into a plate located on left fender. In any correspondence concerning the unit, supply the model and serial numbers to ensure correct information and replacement parts are obtained.

Note: Do not order by reference number if a parts catalog is being used; use the part number.

To order replacement parts from an authorized TORO Distributor, supply the following information:

1. Model and serial numbers.
2. Part number, description, and quantity of parts desired.

The Toro Promise

A One Year Limited Warranty

The Toro Company promises to repair your TORO product if defective in materials or workmanship. The following time periods from the date of purchase apply:

Commercial Products 1 Year

The cost of parts and labor are included, but the customer pays the transportation costs on walk rotary mowers with cutting unit widths of less than 25".

If you feel your TORO Product is defective and wish to rely on The Toro Promise, the following procedure is recommended:

1. Contact your Authorized TORO Distributor or Commercial Dealer (the Yellow Pages of your telephone directory is a good reference source).
2. The TORO Distributor or Commercial Dealer will advise you on the arrangements that can be made to inspect and repair your product.
3. The TORO Distributor or Commercial Dealer will inspect the product and advise you whether the product is defective and, if so, make all repairs necessary to correct the defect without an extra charge to you.

If for any reason you are dissatisfied with the distributor's analysis of the defect or the service performed, you may contact us.

Write:

TORO Commercial Products Service Department
8111 Lyndale Avenue South
Minneapolis, MN 55420

The above remedy of product defects through repair by an Authorized TORO Distributor or Commercial Dealer is the purchaser's sole remedy for any defect.

THERE IS NO OTHER EXPRESS WARRANTY. ALL IMPLIED WARRANTIES OF MERCHANTABILITY AND FITNESS FOR USE ARE LIMITED TO THE DURATION OF THE EXPRESS WARRANTY.

Some states do not allow limitations on how long an implied warranty lasts, so the above limitation may not apply to you.

This Warranty applies only to parts or components which are defective and does not cover repairs necessary due to normal wear, misuse, accidents, or lack of proper maintenance. Regular, routine maintenance of the unit to keep it in proper operating condition is the responsibility of the owner.

All warranty repairs reimbursable under The Toro Promise must be performed by an Authorized Toro Commercial Dealer or Distributor using Toro approved replacement parts.

Repairs or attempted repairs by anyone other than an Authorized TORO Distributor or Commercial Dealer are not reimbursable under the TORO Promise. In addition, these unauthorized repair attempts may result in additional malfunctions, the correction of which is not covered by warranty.

THE TORO COMPANY IS NOT LIABLE FOR INDIRECT, INCIDENTAL OR CONSEQUENTIAL DAMAGES IN CONNECTION WITH THE USE OF THE PRODUCT INCLUDING ANY COST OR EXPENSE OF PROVIDING SUBSTITUTE EQUIPMENT OR SERVICE DURING PERIODS OF MALFUNCTION OR NON-USE.

Some states do not allow the exclusion of incidental or consequential damages, so the above exclusion may not apply to you.

This warranty gives you specific legal rights, and you may also have other rights which vary from state to state.

COUNTRIES OTHER THAN THE UNITED STATES OR CANADA

Customers who have purchased TORO products exported from the United States or Canada should contact their TORO Distributor (Dealer) to obtain guarantee policies for your country, province, or state. If for any reason you are dissatisfied with your Distributor's service or have difficulty obtaining guarantee information, contact the TORO importer. If all other remedies fail, you may contact us at The Toro Company.