



Count on it.

Parts Catalog

**Pivoting Hose Reel Kit
Multi-Pro 5800 Turf Sprayer**

Model No. 41621—Serial No. 315000001 and Up



Ordering Replacement Parts

To order replacement parts, please supply the part number, the quantity, and the description of each part desired.

Understanding Reference Numbers

Each identified part in an illustration has a reference number. The reference number for a part also appears in the parts list, along with other information about the part.

This catalog uses two special reference number formats, one to indicate parts in a service assembly and another to indicate the quantity of a given part in an illustration.

Service Assembly Reference Numbers

Parts in service assemblies have reference numbers in the form a:b. The a represents the reference number of the entire service assembly and the b represents a sequential number unique to each part within the service assembly.

For example, a wheel assembly might be identified by reference number 6, the tire by 6:1, the valve by 6:2, and the wheel by 6:3. When you order the assembly identified by reference number 6, you receive all parts identified by reference numbers 6:1, 6:2, and 6:3. However, you may also order any part individually. Reference numbers of this type appear in illustration and in parts lists.

Reference Numbers Indicating Quantity

In an illustration, if a reference number indicates more than one part, the reference number has the form nX y. The n represents the quantity of the part, the X is the multiplication symbol, and the y represents the reference number.

For example, in an illustration, the reference number 2X 37 means that two of the parts identified by reference number 37 are indicated.

List of Abbreviations

AR: as required

ASM: assembly

BBC: blade brake control

BHTF: button head thread forming

CARR: carriage

CCW: counter clockwise

CW: clockwise

DEG: degrees

DPA: Dual Point Adjustment

ECM: electronic control module

EXT: external

FH: flat head

GA: gauge

HD: heavy-duty

HF: hex flange

HH: hex head

HHF: hex head flange

HHFTF: hex head flange thread forming

HJ: hex jam

HLH: hex lag head

HOC: height-of-cut

HP: high pressure

HSBH: hex socket button head

HSFH: hex socket flat head

HSH: hex socket head

HWH: hex washer head

HWHTF: hex washer head thread forming

HYD: hydraulic

LH: left hand

LP: low pressure

LPG: Liquefied Petroleum Gas

NI: nylon insert

NPTF: national pipe thread fine

PFH: phillips flat head

PPH: phillips pan head

PPHTF: phillips pan head thread forming

PRH: phillips round head

PTH: phillips truss head

PTO: power-take-off

RH: right hand

ROPS: roll-over protection system

RRB: rear roller brush

SFH: slotted fillister head

SHH: slotted hex head

SHWH: slotted hex washer head

SPH: slotted pan head

SQH: square head

SRH: slotted round head

STD: standard

TAP: self tapping

TTH: torx truss head

Contents

Hose Reel and Spray Gun Assembly	4
Hose Reel Frame Assembly No. 127-3910	5
Spray Gun Assembly No. 120-8610	6
Hose Reel Mount and Supply Hose Assembly	8
Hose Reel Valve Assembly No. 130-7321	9

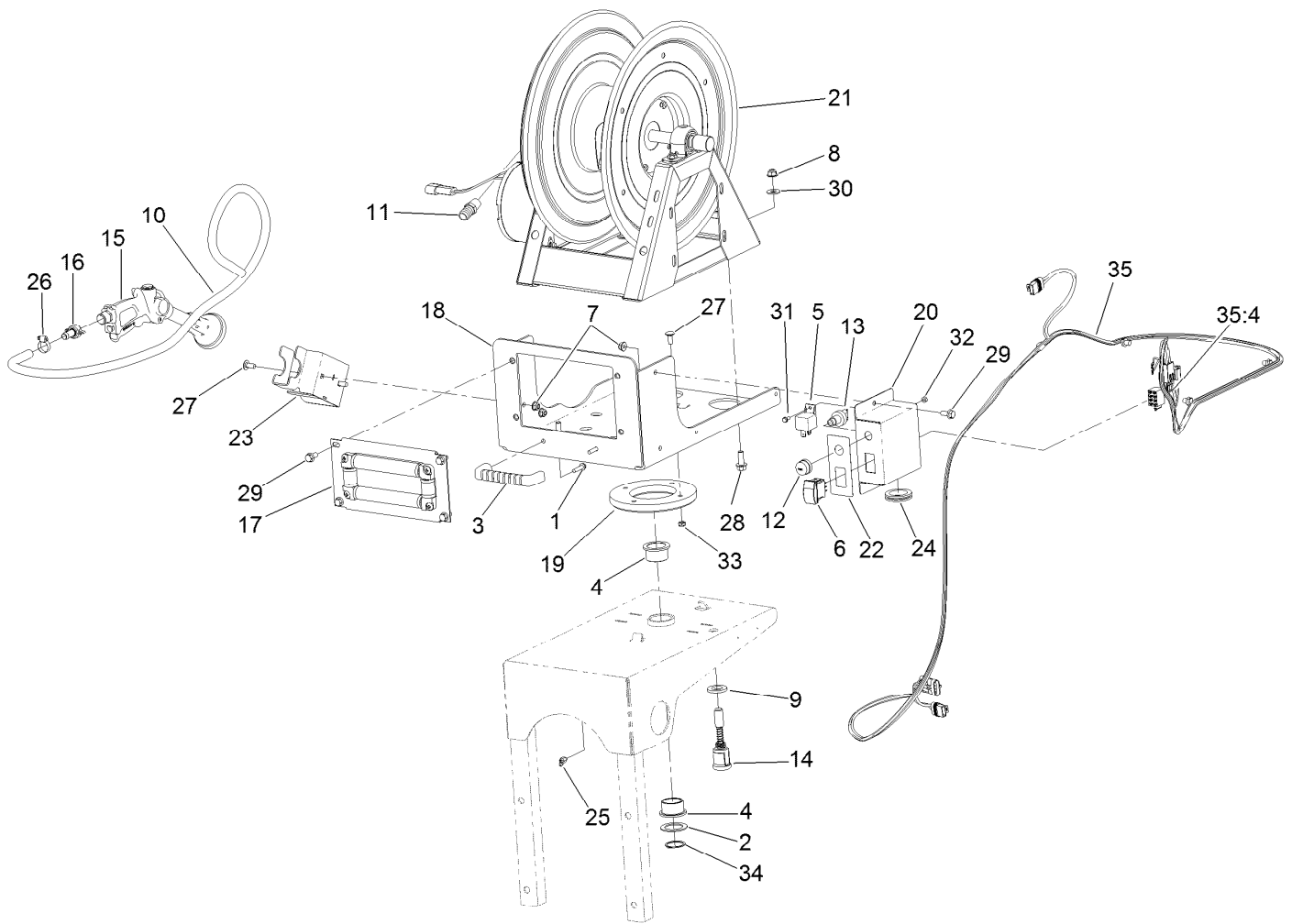

Hose Reel and Spray Gun Assembly

Ref.	Part Number	Qty.	Description	Ref.	Part Number	Qty.	Description
1	46-8092	2	Screw-Plastite	19	125-8051	1	Slide-Plastic
2	62-2170	1	Washer-Thrust	20	125-8086-03	1	Box-Switch, Hose Reel
3	65-5100	1	Handle-Door	21	127-3910	1	Hose Reel ASM
4	93-4510	2	Bushing-Caster	22	127-3953	1	Decal-Hose Reel
5	99-7435	1	Relay-Power	23	127-9713-03	1	Hand Gun Bracket ASM
6	100-1535	1	Switch	24	240-7	1	Grommet-Rubber
7	104-8300	4	Nut-Flange, NI	25	302-11	1	Fitting-Lube, 45 DEG
8	104-8301	4	Nut-Flange, NI	26	2412-36	1	Clamp-Hose
9	105-4551	1	Washer-Flat	27	3230-23	6	Screw-CARR
10	107-8756	1	Hose-Hose Reel	28	3234-42	4	Screw-HHF
11	110-5065	1	Hosebarb	29	3234-47	6	Screw-HHF
12	112-3313	1	Nut-Weatherproof	30	3256-4	4	Washer-Flat
13	112-3324	1	Switch-Horn	31	3290-321	1	Screw-HWH
14	116-0104	1	Pin-Spring	32	3296-2	1	Nut-Lock, NI
15	120-8610	1	Spray Gun ASM	33	3296-47	4	Nut-Lock, NI
16	121-4982	1	Hosebarb-Spray Gun	34	32120-84	1	Ring-Snap, External
17	121-4983	1	Bracket-Roller	35	122-0362	1	Harness-Wire, Hose Reel
18	125-4080-03	1	Plate-Pivot	35:4	99-6124	1	Fuse-40 Amp

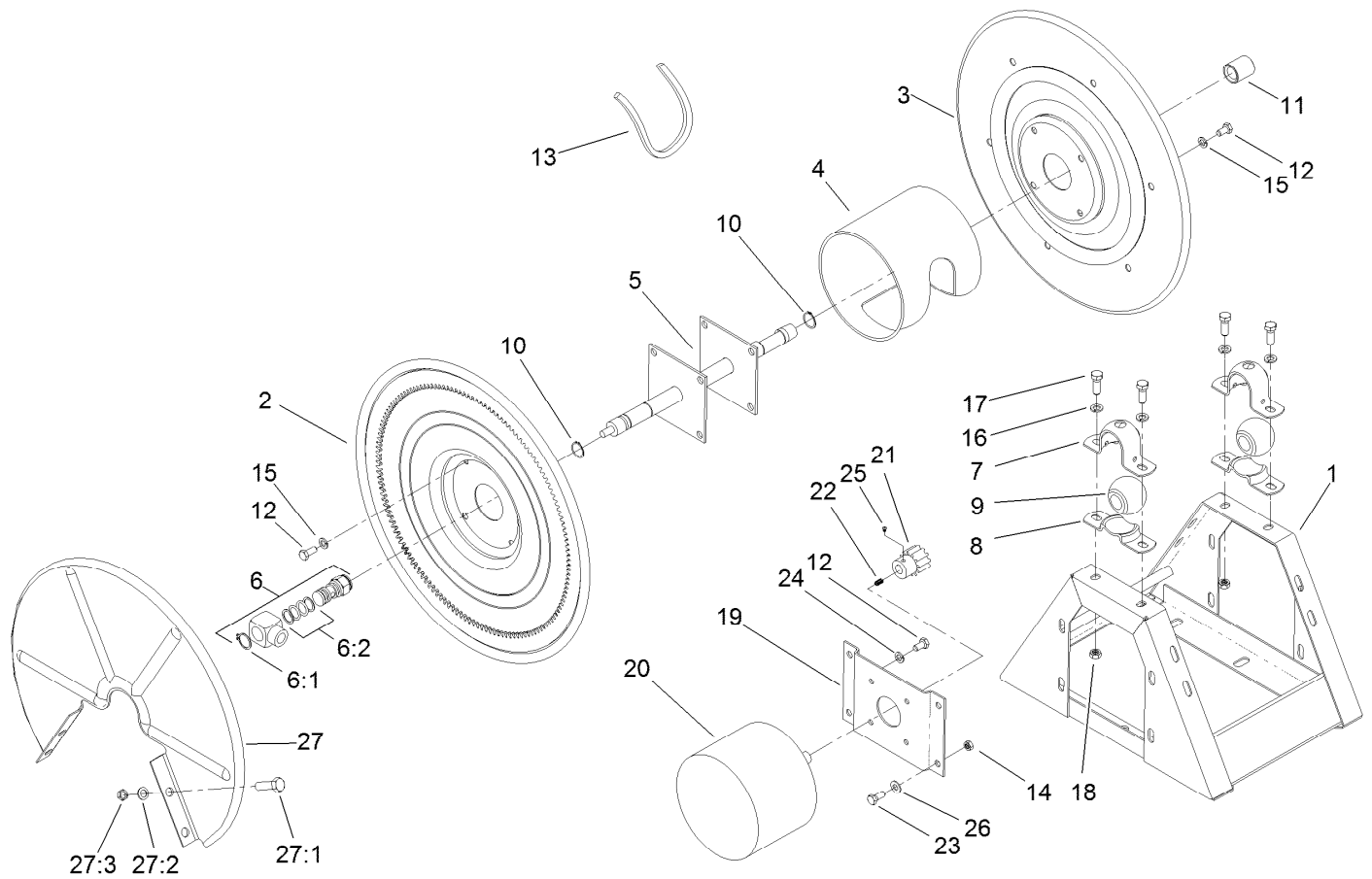

Hose Reel Frame Assembly No. 127-3910

Ref.	Part Number	Qty.	Description	Ref.	Part Number	Qty.	Description
1	104-8803	1	Frame-Hose Reel	15	3256-23	16	Washer-Flat
2	104-8804	1	Disc And Gear	16	3253-21	4	Washer-Lock
3	104-8805	1	Disc-Crank, Side	17	323-6	4	Screw-HH
4	104-8806	1	Drum-Center	18	32128-21	1	Nut-HF
5	104-8807	1	Axle	19	104-8815	1	Bracket-Motor, 12V Dc
6	104-8808	1	Swivel ASM	20	131-0282	1	Motor 12V Dc
6:1	104-8812	1	Ring-Retainer	21	104-8817	1	Pinion
6:2	104-8864	1	Swivel Seal Kit	22	104-8818	4	Key
7	104-8809	2	Block-Pillow, Top	23	322-5	8	Screw-HH
8	104-8810	2	Block-Pillow, Bottom	24	3253-4	1	Washer-Lock
9	104-8811	2	Bearing	25	104-8819	4	Screw-Set
10	104-8812	4	Ring-Retainer	26	3256-23	4	Washer-Flat
11	104-8813	1	Cap-Pipe	27	104-8715	1	Chainguard-Reel, Hose
12	322-3	8	Screw-HH	27:1	322-5	4	Screw-HH
13	104-8814	1	Trim-Edge, Drum	27:2	3256-23	4	Washer-Flat
14	3296-29	8	Nut-Lock, NI	27:3	3296-29	4	Nut-Lock, NI

Spray Gun Assembly No. 120-8610

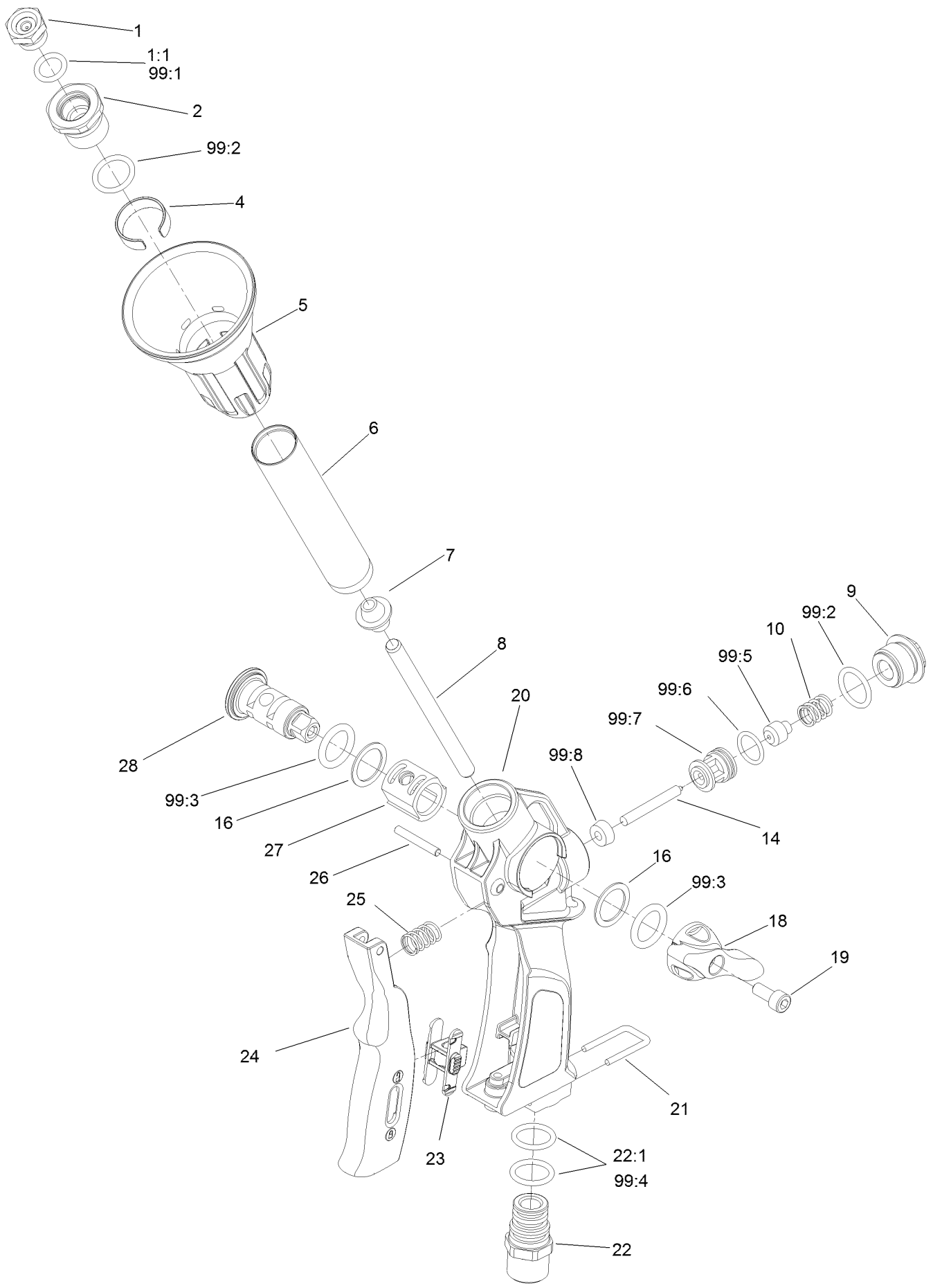

Spray Gun Assembly No. 120-8610 (continued)

<i>Ref.</i>	<i>Part Number</i>	<i>Qty.</i>	<i>Description</i>	<i>Ref.</i>	<i>Part Number</i>	<i>Qty.</i>	<i>Description</i>
1	121-4950	1	Nozzle-2.3Mm	22:1	121-4972	2	O-Ring
1:1	121-4951	1	O-Ring	23	121-4974	1	Slide-Lever
2	121-4952	1	Head-Nozzle Holder	24	121-4975	1	Lever-Spraygun
4	121-4954	1	Ring-Spacer	25	121-4977	1	Spring
5	121-4955	1	Spreader-Micro Jet	26	121-4978	1	Pin-Lever
6	121-4956	1	Tube-Spray Gun	27	121-4979	1	Cover-Drum
7	121-4957	1	Conveyor-Inner	28	121-4980	1	Drum-Regulation
8	121-4958	1	Tube-Spray Gun, Inner	99	121-4981	1	Spray Gun Seal Kit ●
9	121-4959	1	Drum-Regulation	99:1	121-4951	1	O-Ring
10	121-4960	1	Spring-Spray Gun	99:2	121-4953	2	Gasket
14	121-4964	1	Pin-Hinge	99:3	121-4967	2	O-Ring
16	121-4966	2	Washer-Teflon	99:4	121-4972	2	O-Ring
18	121-4968	1	Lever-Drum, Spray Gun	99:5	121-4962	1	Plunger-Cone
19	121-4969	1	Screw	99:6	121-4961	1	O-Ring
20	121-4970	1	Grip-Spray Gun	99:7	121-4963	1	Box And Seat
21	121-4971	1	Fork	99:8	121-4965	1	Seal
22	121-4973	1	Hose-Tail				

● Not illustrated

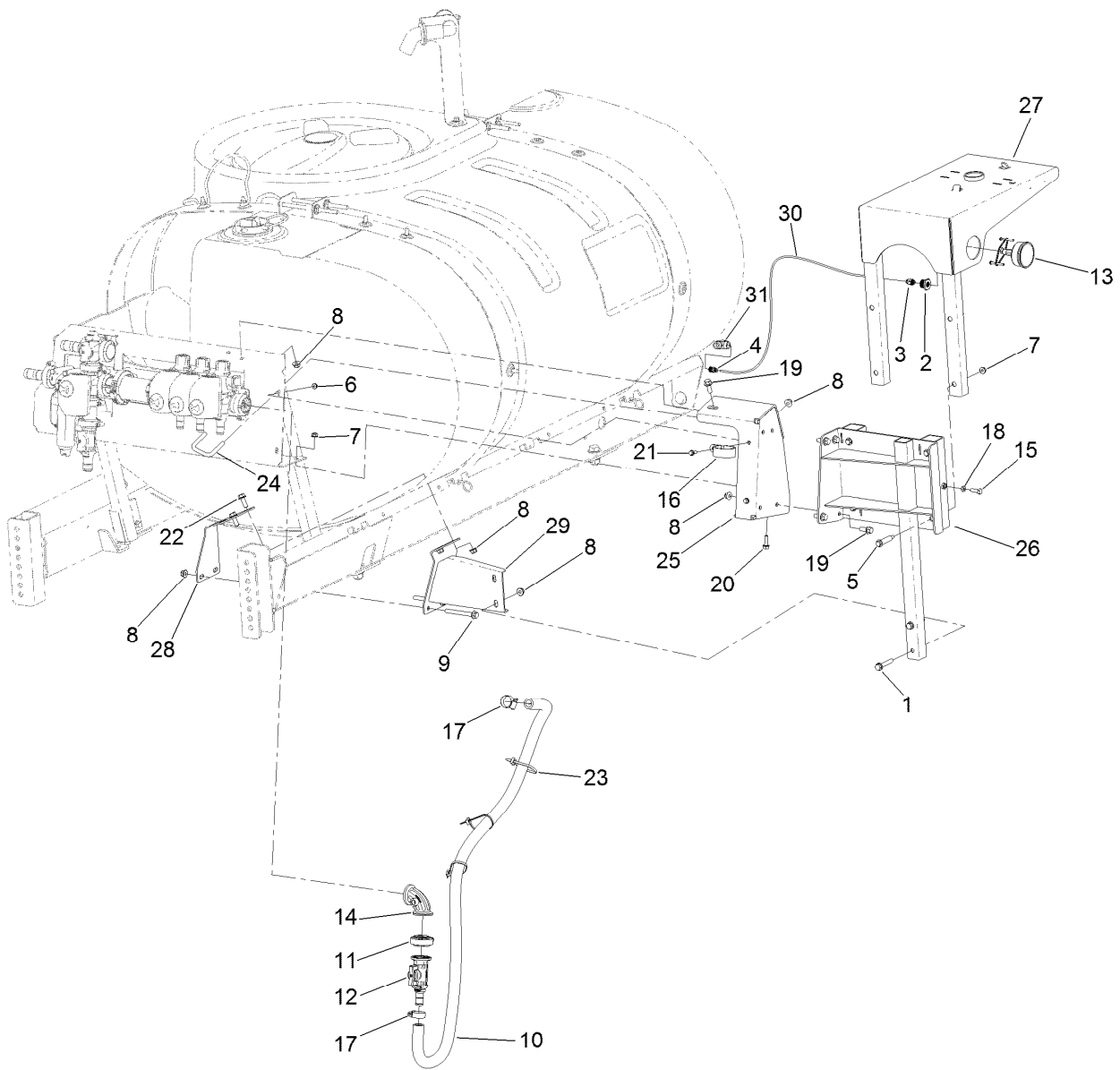

Hose Reel Mount and Supply Hose Assembly

Ref.	Part Number	Qty.	Description	Ref.	Part Number	Qty.	Description
1	100-2592	2	Screw-HHF	17	2412-129	2	Clamp-Hose
2	100-8665	1	Reducer-Gauge, Pressure	18	3218-2	2	Nut-Jam
3	100-8667	1	Coupler-Reducer	19	3234-11	5	Screw-HHF
4	100-8674	1	Coupler-Tube	20	3234-17	1	Screw-HHF
5	100-9880	4	Bolt-Shoulder	21	3234-4	2	Screw-HHF
6	104-7201	2	Nut-HF	22	3234-42	2	Screw-HHF
7	104-8300	5	Nut-Flange, NI	23	3290-378	3	Tie-Cable
8	104-8301	13	Nut-Flange, NI	24	99-8444	1	U-Bolt
9	116-4701	2	Screw-HHF	25	130-7154-03	1	Bracket-Support, Upper
10	119-0491	1	Hose-Supply	26	130-7155-03	1	Bracket-Support
11	127-9829	1	Clamp/Gasket Kit	27	130-7160-03	1	Base-Frame
12	130-7321	1	Hose Reel Valve ASM	28	130-7163-03	1	Bracket-Lower
13	120-8546	1	Gauge-Pressure	29	130-7164-03	1	Bracket-Lower
14	131-3726	1	Fitting-Elbow, 90 DEG	30	130-7223	1	Tube-Pressure Gauge
15	322-5	2	Screw-HH	31	2815-16	1	Fitting-HYD, Tee
16	2412-107	1	Clamp-R				

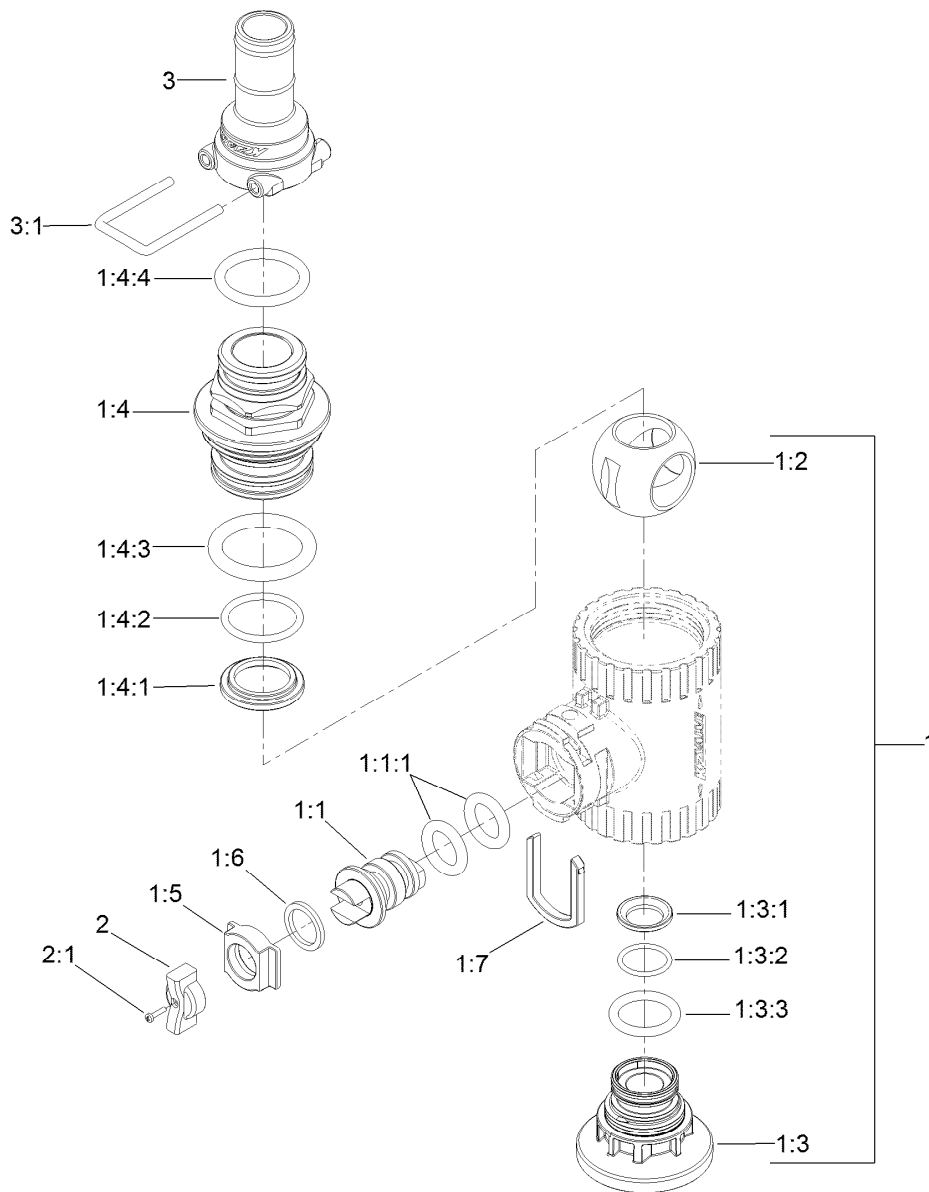

Hose Reel Valve Assembly No. 130-7321

<i>Ref.</i>	<i>Part Number</i>	<i>Qty.</i>	<i>Description</i>	<i>Ref.</i>	<i>Part Number</i>	<i>Qty.</i>	<i>Description</i>
1	131-0250	1	2-Way Valve On/Off Kit	1:4:2	127-1188	1	O-Ring-Seat, Ball
1:1	130-8248	1	Vavle Stem Kit	1:4:3	127-1189	1	O-Ring-Endcap
1:1:1	127-1197	2	O-Ring-Stem	1:4:4	127-1187	1	O-Ring-Endcap
1:2	131-0252	1	Ball-2-Way	1:5	127-1196	1	Washer-Stem, Valve
1:3	130-8249	1	Endcap Kit	1:6	127-1195	1	Seat-Steam, Valve
1:3:1	127-1192	1	Seat-Ball	1:7	127-1190	1	Fork-Steam, Valve
1:3:2	127-1188	1	O-Ring-Seat, Ball	2	131-0268	1	Hose Reel Handle Kit
1:3:3	127-1189	1	O-Ring-Endcap	2:1	131-0263	1	Screw-Handle
1:4	130-7317	1	Endcap Kit	3	127-9807	1	Straight Fitting Kit
1:4:1	127-1192	1	Seat-Ball	3:1	127-1175	1	Fork

Notes:

Notes:



Count on it.