



Count on it.

Parts Catalog

**Commercial Walk-Behind Mower
Fixed Deck, Pistol Grip, Gear Drive with 32in
Cutting Unit**

Model No. 30632—Serial No. 315000001 and Up



Ordering Replacement Parts

To order replacement parts, please supply the part number, the quantity, and the description of each part desired.

Understanding Reference Numbers

Each identified part in an illustration has a reference number. The reference number for a part also appears in the parts list, along with other information about the part.

This catalog uses two special reference number formats, one to indicate parts in a service assembly and another to indicate the quantity of a given part in an illustration.

Service Assembly Reference Numbers

Parts in service assemblies have reference numbers in the form a:b. The a represents the reference number of the entire service assembly and the b represents a sequential number unique to each part within the service assembly.

For example, a wheel assembly might be identified by reference number 6, the tire by 6:1, the valve by 6:2, and the wheel by 6:3. When you order the assembly identified by reference number 6, you receive all parts identified by reference numbers 6:1, 6:2, and 6:3. However, you may also order any part individually. Reference numbers of this type appear in illustration and in parts lists.

Reference Numbers Indicating Quantity

In an illustration, if a reference number indicates more than one part, the reference number has the form nX y. The n represents the quantity of the part, the X is the multiplication symbol, and the y represents the reference number.

For example, in an illustration, the reference number 2X 37 means that two of the parts identified by reference number 37 are indicated.

List of Abbreviations

AR: as required

ASM: assembly

BBC: blade brake control

BHTF: button head thread forming

CARR: carriage

CCW: counter clockwise

CW: clockwise

DEG: degrees

DPA: Dual Point Adjustment

ECM: electronic control module

EXT: external

FH: flat head

GA: gauge

HD: heavy-duty

HF: hex flange

HH: hex head

HHF: hex head flange

HHFTF: hex head flange thread forming

HJ: hex jam

HLH: hex lag head

HOC: height-of-cut

HP: high pressure

HSBH: hex socket button head

HSFH: hex socket flat head

HSH: hex socket head

HWH: hex washer head

HWHTF: hex washer head thread forming

HYD: hydraulic

LH: left hand

LP: low pressure

LPG: Liquefied Petroleum Gas

NI: nylon insert

NPTF: national pipe thread fine

PFH: phillips flat head

PPH: phillips pan head

PPHTF: phillips pan head thread forming

PRH: phillips round head

PTH: phillips truss head

PTO: power-take-off

RH: right hand

ROPS: roll-over protection system

RRB: rear roller brush

SFH: slotted fillister head

SHH: slotted hex head

SHWH: slotted hex washer head

SPH: slotted pan head

SQH: square head

SRH: slotted round head

STD: standard

TAP: self tapping

TTH: torx truss head

Contents

Engine and Exhaust Assembly.....	4
Fuel System Assembly	6
Frame and Transmission Assembly	7
Drive Wheel and Brake Assembly	9
Handle Control Assembly	11
Handle Assembly	12
Deck and Shield Assembly	13
Deck Decal Assembly No. 110-6901.....	14
Deflector Assembly No. 119-6529.....	15
Idler Arm and Caster Wheel Assembly	16
Spindle and Blade Assembly	18
Cutter Housing Assembly No. 107-4065	19
Attachments and Accessories	20

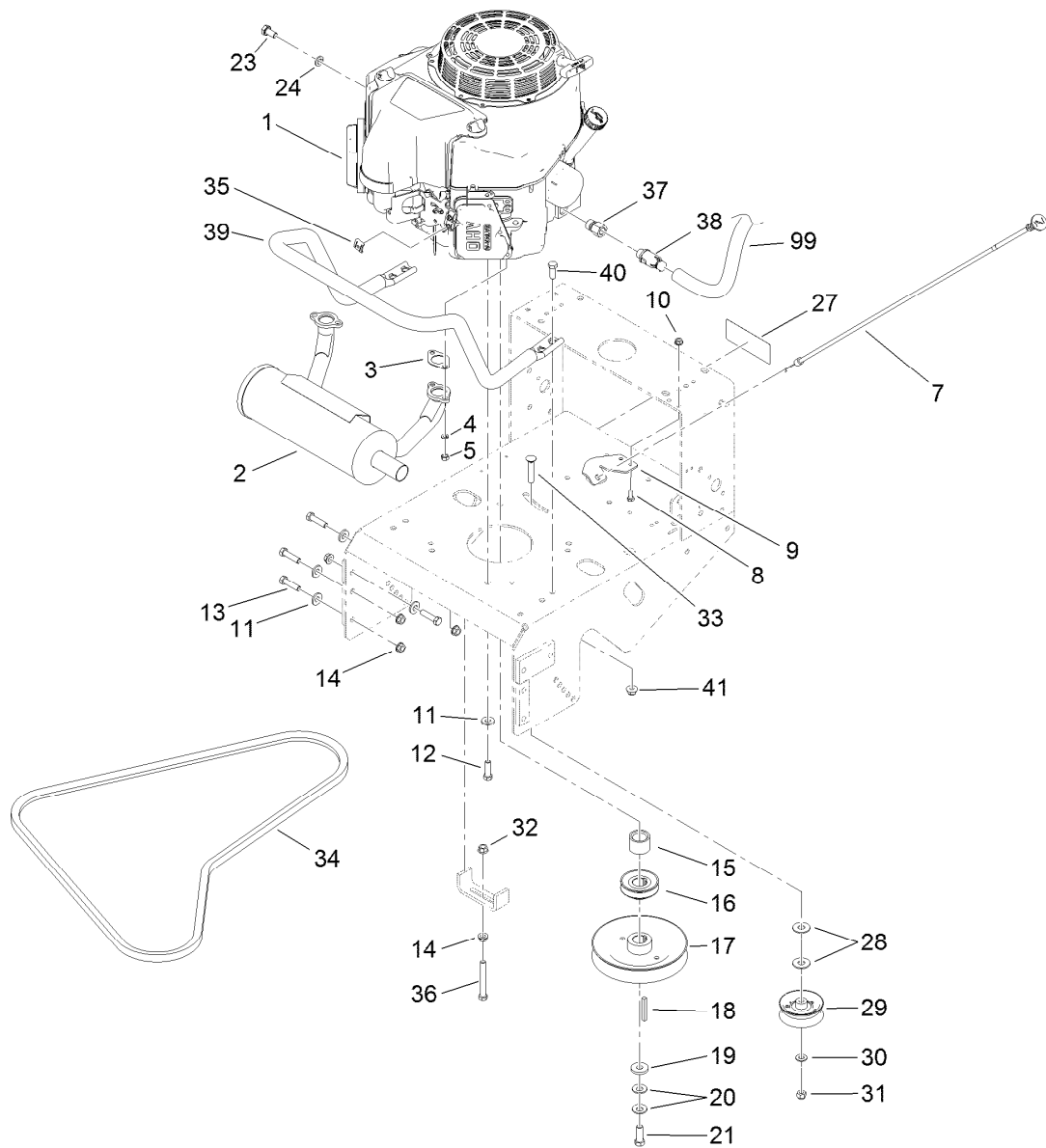

Engine and Exhaust Assembly

Ref.	Part Number	Qty.	Description	Ref.	Part Number	Qty.	Description
1		1	Engine-Kawasaki, Fs481V-As06 ●■	19	1-373034	1	Washer
2	116-3734	1	Muffler-Horizontal, Offset	20	1-603610	2	Washer-Spring
3	1-653313	2	Gasket-Exhaust	21	116-3702	1	Screw-HH
4	114-3550	4	Washer-Lock, Spring	23	33114-016	1	Screw-HH
5	114-3549	4	Nut	24	3253-4	1	Washer-Lock
7	103-1796	1	Cable-Choke	27	126-1400	1	Decal-Warning, Sulky
8	321-3	2	Screw-HH	28	3256-5	2	Washer-Flat
9	103-1797-01	1	Bracket-Cable, Choke	29	130-8362	1	Pulley-Idler, Flat
10	32128-33	2	Nut-HF	30	3256-24	1	Washer-Flat
11	98-5975	12	Washer-Belleville	31	3296-39	1	Nut-Lock, NI
12	323-7	4	Screw-HH	32	32128-21	1	Nut-HF
13	323-8	8	Screw-HH	33	3231-6	1	Screw-CARR
14	3290-357	9	Nut-HHF, Whiz	34	1-323745	1	Belt-V
15	1-633453	1	Spacer-Clutch	35	81-1690	1	Clamp-Cable
16	103-1666	1	Sheave-Transmission	36	323-14	1	Screw-HH
17	103-1667	1	Sheave	37	103-1966	1	Adapter
18	103-4177	1	Key	38	120-4321	1	Valve-Drain, Oil
				39	116-6278-03	1	Guard-Muffler

● Not serviced separately

■ Obtain parts from www.kawpowerpc.com

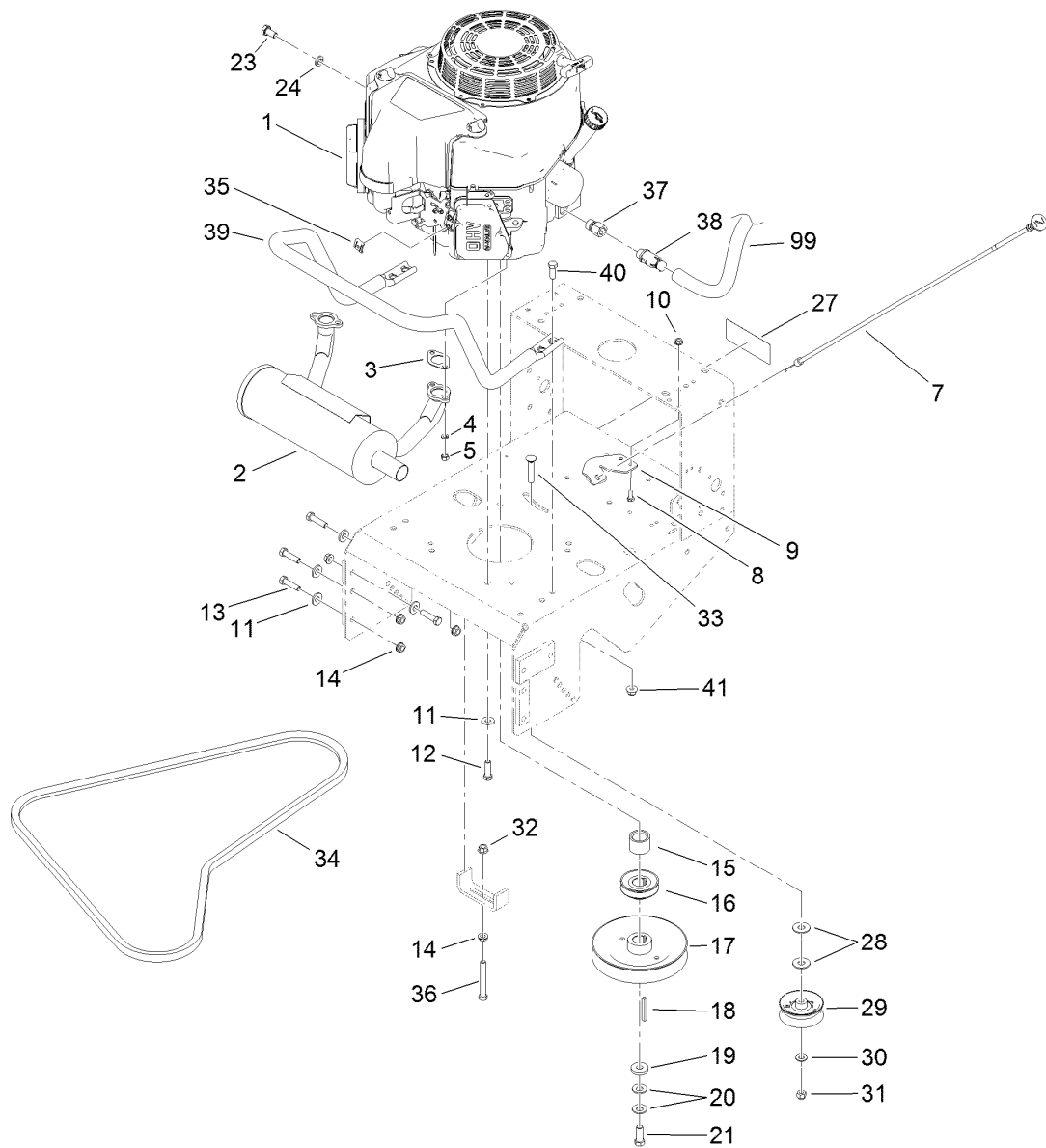

Engine and Exhaust Assembly (continued)

Ref.	Part Number	Qty.	Description
40	323-6	4	Screw-HH

Ref.	Part Number	Qty.	Description
41	104-8301	4	Nut-Flange, NI
99	103-1964	1	Hose-Drain, Oil

● Not serviced separately

■ Obtain parts from www.kawpowerpc.com

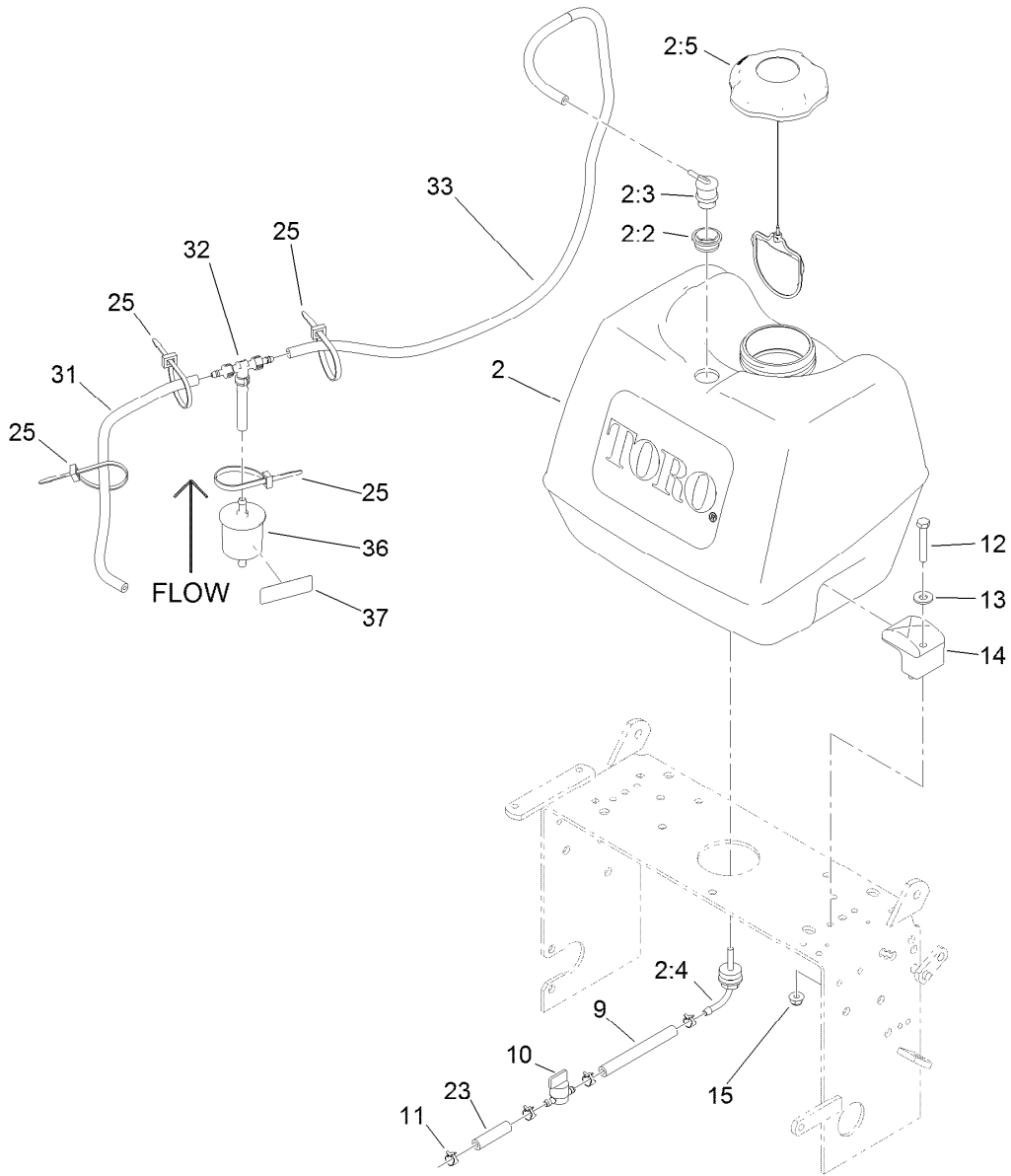

Fuel System Assembly

Ref.	Part Number	Qty.	Description	Ref.	Part Number	Qty.	Description
2	126-1526	1	Fuel Tank ASM	14	107-4543	2	Clamp
2:2	114-0284	1	Grommet	15	104-8300	2	Nut-Flange, NI
2:3	119-3547	1	Valve-Vent, Fuel	23	99-9415	1	Hose-Fuel
2:4	103-2605	1	Fitting-Fuel, Bulkhead	25	3290-378	4	Tie-Cable
2:5	120-5461	1	Cap-Fuel, Ratcheting	31	115-7872	1	Hose-Fuel
9	109-0650	1	Hose-Fuel	32	116-5464	1	Tee And Check
10	1-603770	1	Valve-Fuel	33	116-4346	1	Hose-Emissions
11	2412-98	4	Clamp-Hose	36	120-2235	1	Filter-Fuel
12	322-10	2	Screw-HH	37	116-4769	1	Decal-Filter, Emissions
13	3256-3	2	Washer-Flat				

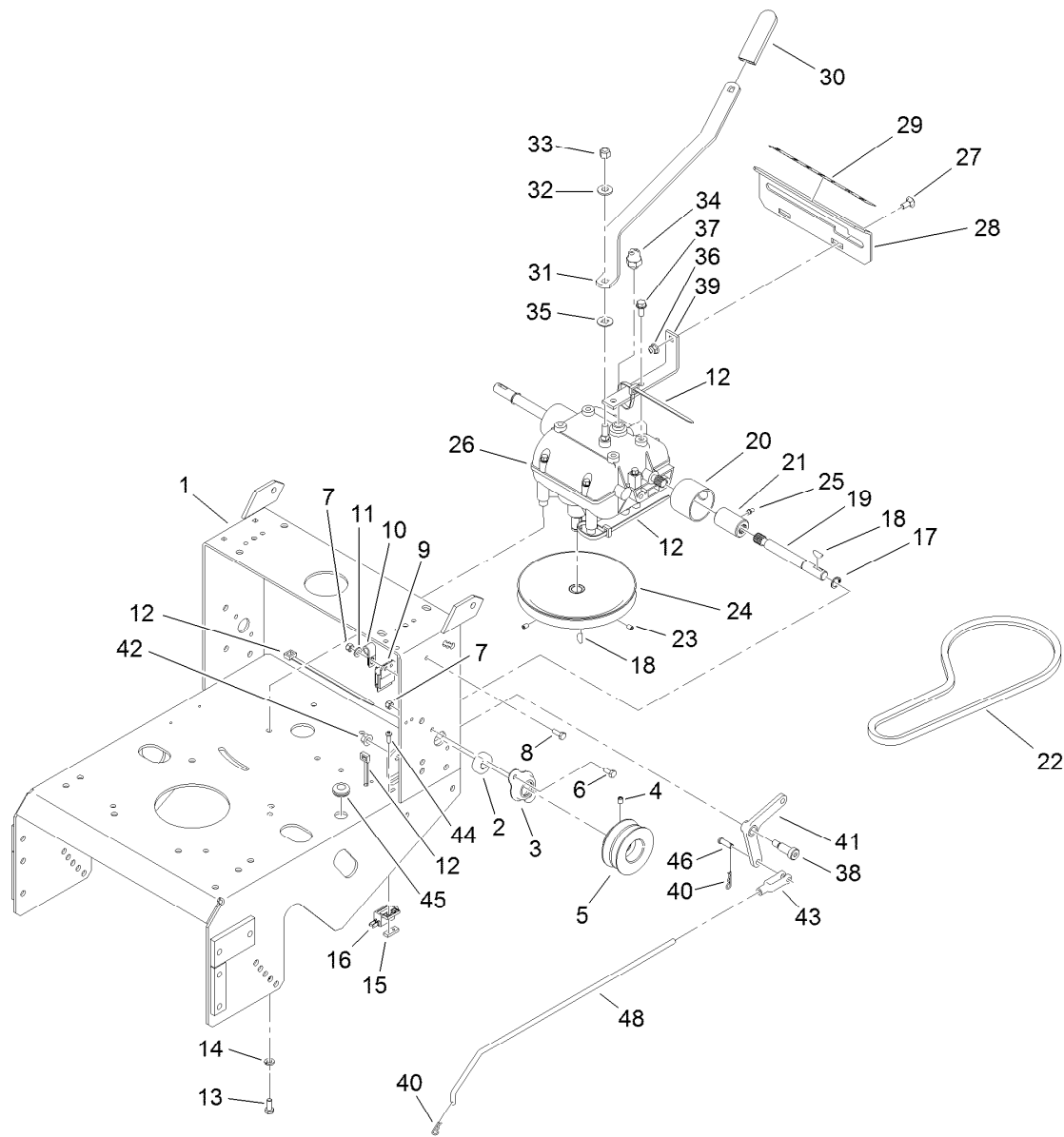

Frame and Transmission Assembly

Ref.	Part Number	Qty.	Description	Ref.	Part Number	Qty.	Description
1	116-6084-01	1	Frame-Gear	22	1-323630	1	V-Belt
2	1-323252	2	Bearing-Shaft	23	3245-41	2	Screw-HSH
3	1-323254	2	Flange-Output	24	1-323278	1	Sheave-Transmission
4	3246-18	2	Setscrew	25	302-19	2	Fitting-Grease
5	103-6512	2	Sheave-Transmission	26	1-323500	1	Transmission
6	321-3	4	Screw-HH	27	3230-1	2	Bolt-CARR
7	3296-42	5	Nut-Lock, NI	28	1-323387-03	1	Plate-Shift
8	321-4	1	Screw-HH	29	105-4104	1	Decal-Speed, Ground
9	1-323430	1	Module-Interlock	30	1-303020	1	Grip-Lever
10	1-513762	1	Clip-Loom	31	98-3274-03	1	Lever-Shift
11	3256-22	1	Washer-Flat	32	98-5975	1	Washer-Belleville
12	1-303335	3	Tie-Plastic	33	3296-6	1	Nut-Lock
13	322-3	4	Screw-HH	34	1-303282	1	Switch-Start, Neutral
14	1-805005	4	Washer-Lock	35	1-323379	1	Washer
15	1-633181	1	Plate-Tapped	36	104-8300	2	Nut-Flange, NI
16	1-513051	1	Switch-Open, Normally	37	32144-11	4	Screw-HWHTF
17	32151-62	2	Ring-Retaining	38	1-603403	1	Bolt-Shoulder
18	3257-5	3	Key-Woodruff	39	1-323389-03	2	Bracket-Plate, Shift
19	1-323502	2	Shaft-Transmission	40	1-806003	2	Pin-Cotter, Hair
20	51-4220	2	Guard-Coupler	41	1-303186	1	Bellcrank
21	1-323680	2	Coupler	42	3290-357	1	Nut-HHF, Whiz

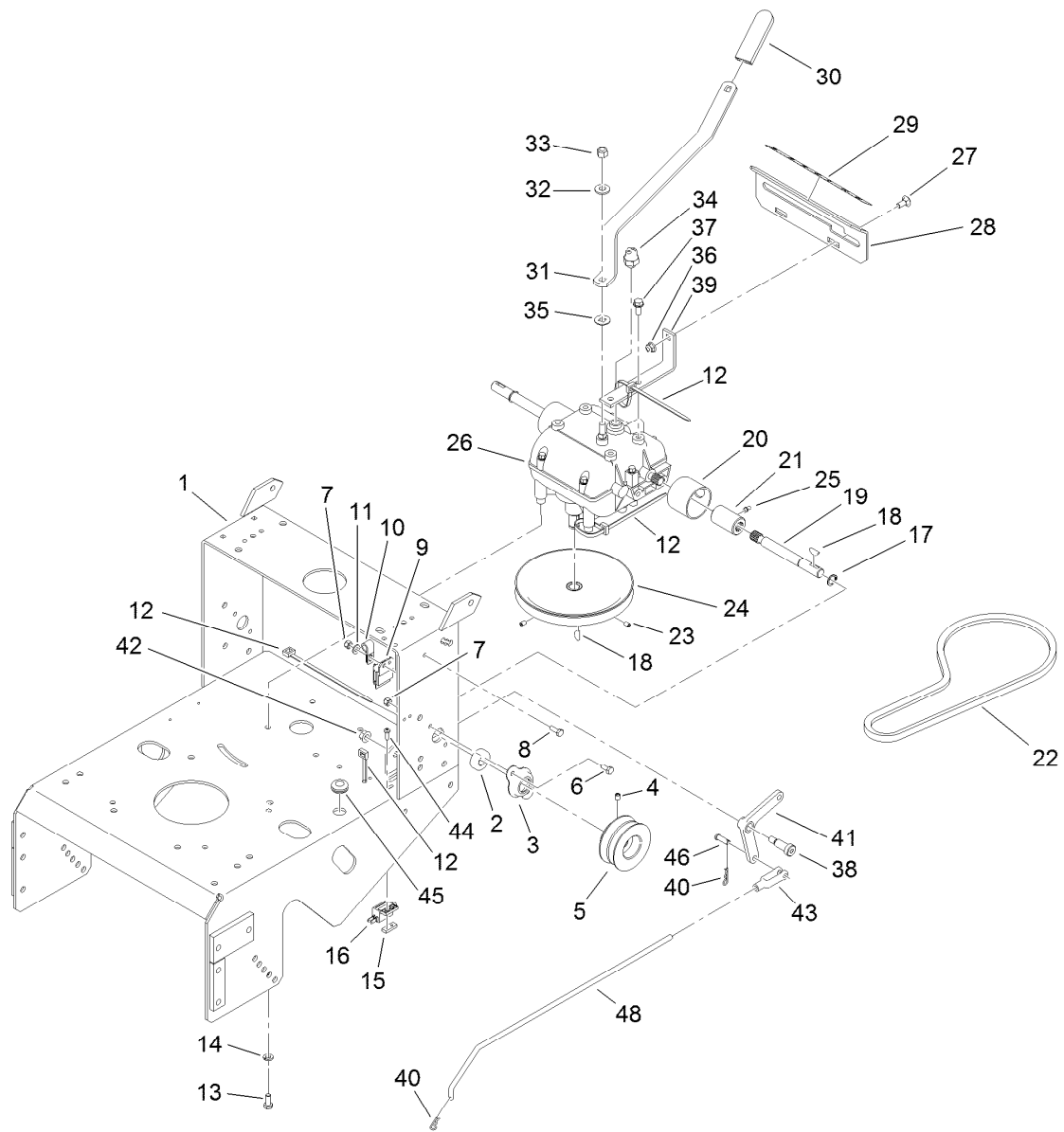

Frame and Transmission Assembly (continued)

<i>Ref.</i>	<i>Part Number</i>	<i>Qty.</i>	<i>Description</i>	<i>Ref.</i>	<i>Part Number</i>	<i>Qty.</i>	<i>Description</i>
43	1-303105	1	Yoke-Adjustable	46	1-808280	1	Pin-Clevis
44	3290-500	2	Screw-PPH	48	1-323303	1	Arm-Assist, Linkage
45	1-543296	1	Grommet				

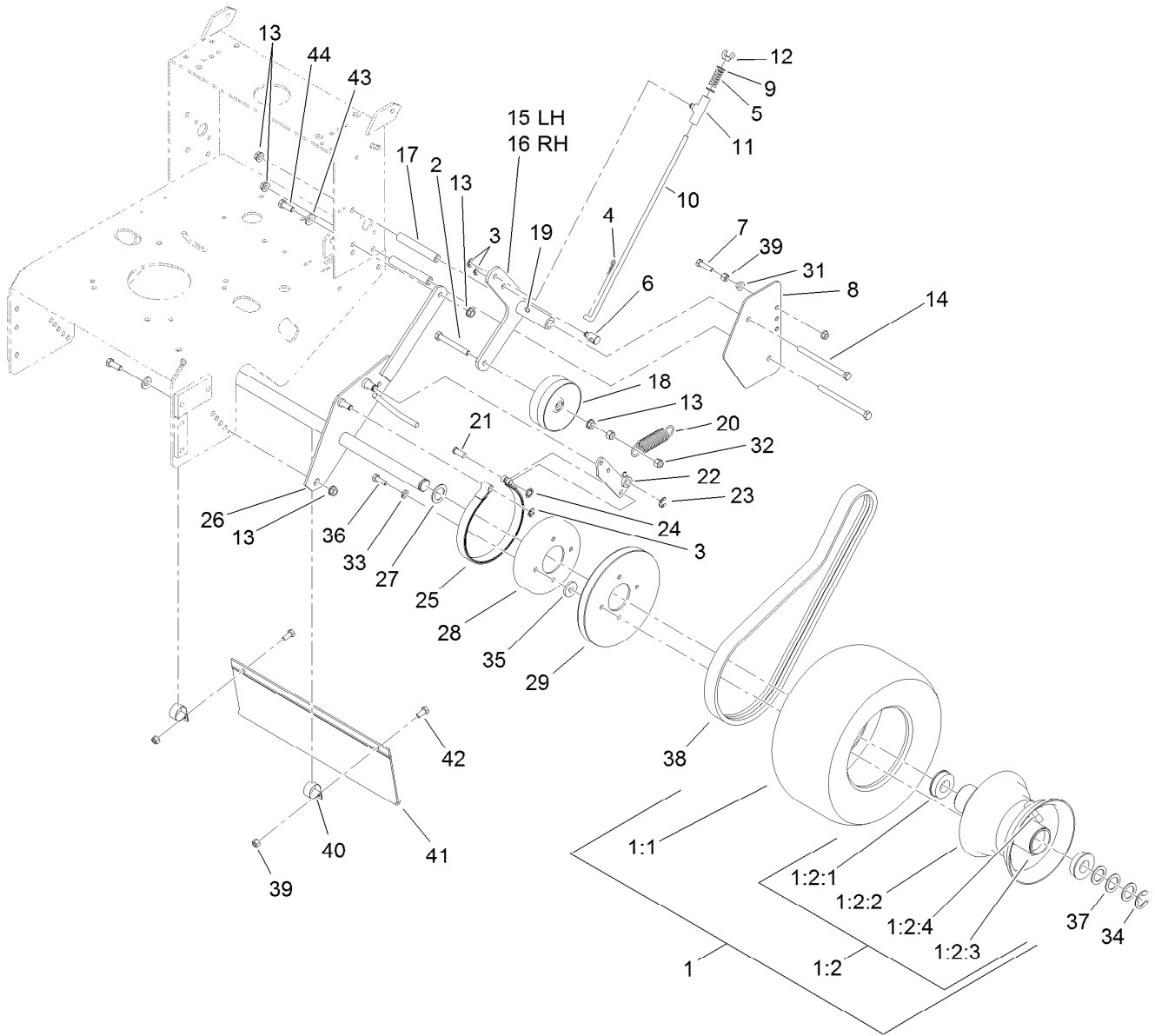

Drive Wheel and Brake Assembly

Ref.	Part Number	Qty.	Description	Ref.	Part Number	Qty.	Description
1	130-8365	2	Wheel And Tire ASM	13	3290-357	10	Nut-HHF, Whiz
1:1	130-8368	1	Tire	14	323-39	4	Screw-HH
1:2	130-4566	1	Wheel And Hub ASM	15	116-7542-03	1	Arm-Idler, LH
1:2:1	1-323329	2	Bearing-Flanged	16	116-7543-03	1	Arm-Idler, RH
1:2:2		1	Rim ASM ●	17	1-323283	4	Spacer-Shield
1:2:3		1	Fitting-Grease ●	18	1-323352	2	Idler-Wheel, Drive
1:2:4		1	Valve Stem And Cap ●	19	302-19	2	Fitting-Grease
2	99-8664	2	Screw-HH	20	1-603402	2	Spring-Extension
3	32151-47	6	Ring-Retaining	21	1-323307	2	Pin-Clevis
4	1-806003	2	Pin-Cotter, Hair	22	103-1611-03	2	Arm-Brake
5	1-323245	2	Spring-Compression	23	32120-47	2	Ring-Retaining, External
6	103-1864	2	Swivel-Lever, Drive	24	1-803051	2	Nut-Push
7	116-3515	2	Screw-HH, Special	25	1-323262	2	Band-Brake
8	1-323287-01	2	Shield-Wheel, Drive	26	1-322141-03	1	Axle
9	3256-23	4	Washer-Flat	27	1-543436	2	Washer-Spacer
10	1-323548	2	Linkage-Brake	28	1-323261	2	Drum-Brake
11	110-5866	2	Swivel-Brake	29	1-323349	2	Sheave-Wheel, Drive
12	1-513959	2	Wingnut-Nylock	31	32128-20	4	Nut-HF

● Not serviced separately

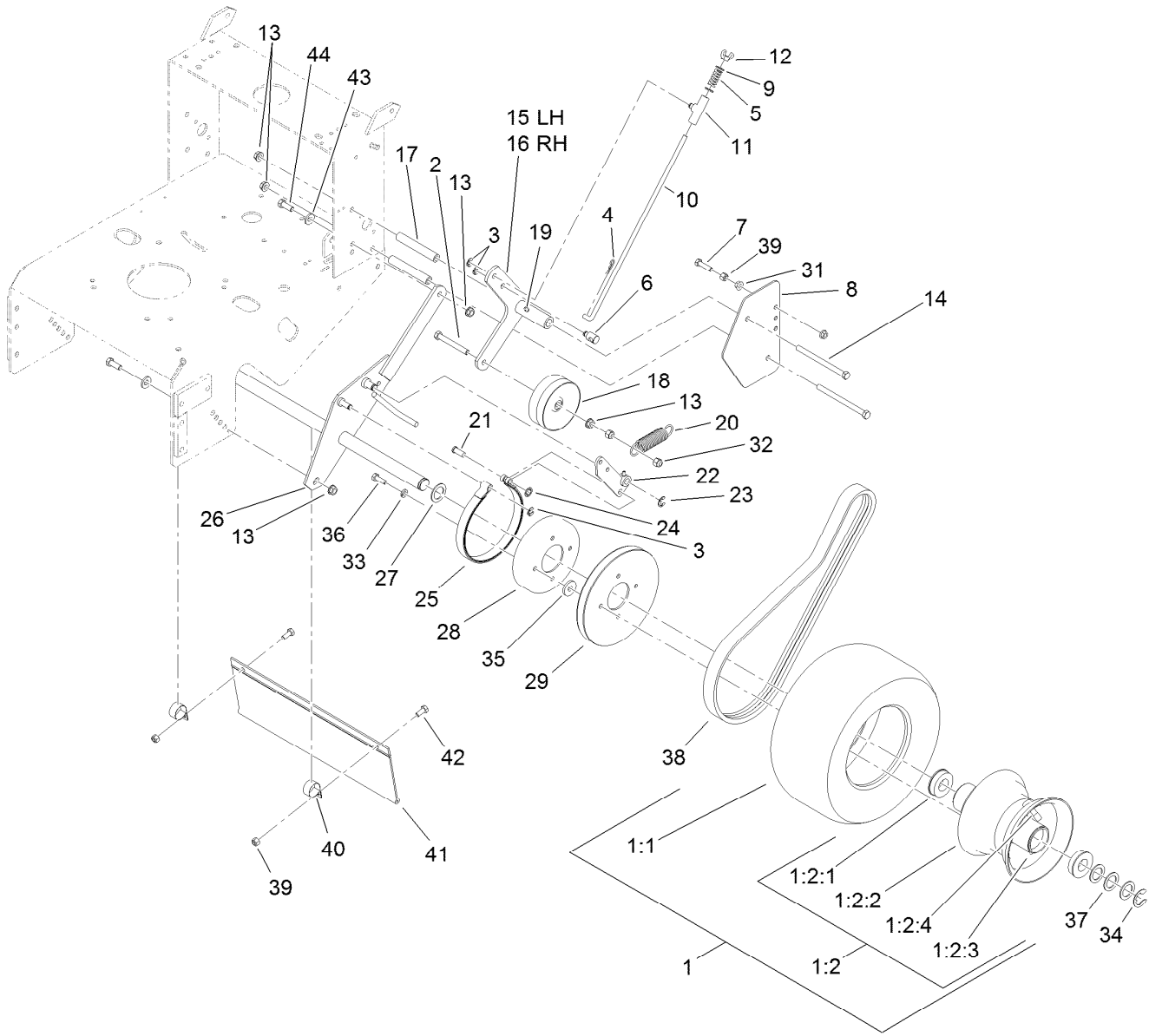

Drive Wheel and Brake Assembly (continued)

Ref.	Part Number	Qty.	Description	Ref.	Part Number	Qty.	Description
32	3296-39	4	Nut-Lock, NI	39	3296-29	4	Nut-Lock, NI
33	1-805005	8	Washer-Lock	40	2412-104	2	Clamp-R
34	1-808519	2	Ring-Snap	41	98-3259	1	Shield-Trailing
35	1-373034	8	Washer	42	322-3	2	Screw-HH
36	322-5	8	Screw-HH	43	98-5975	4	Washer-Belleville
37	1-523157	6	Washer-Spacer	44	323-6	4	Screw-HH
38	1-323744	2	Belt-Drive, Wheel				

● Not serviced separately

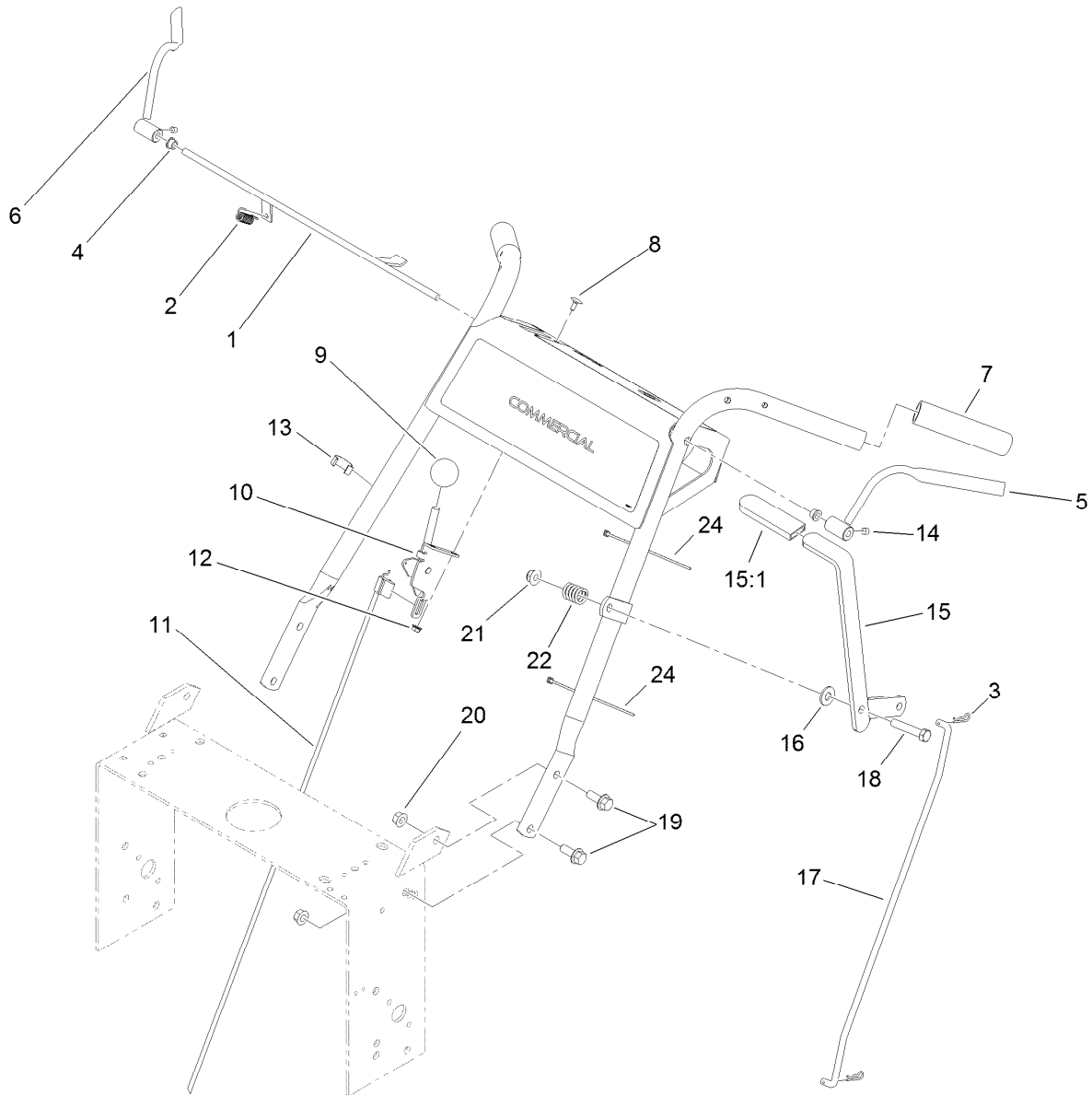

Handle Control Assembly

<i>Ref.</i>	<i>Part Number</i>	<i>Qty.</i>	<i>Description</i>	<i>Ref.</i>	<i>Part Number</i>	<i>Qty.</i>	<i>Description</i>
1	106-2717-03	1	Rod-CONTROL, Operator Presence	12	32128-17	2	Nut-Lock, Flange
2	1-303363	1	Spring-Extension	13	1-303088	1	Clip-Cable
3	1-806003	2	Pin-Cotter, Hair	14	1-803322	2	Screw-Set
4	1-303365	2	Bushing-Nylon	15	116-6331	1	Lever ASM
5	106-5485	1	LH Operator Presence Control Lever ASM	15:1	1-303020	1	Grip-Lever
6	106-5486	1	RH Operator Presence Control Lever ASM	16	3256-4	1	Washer-Flat
7	104-9838	2	Grip-Foam	17	1-323298	1	Linkage-Blade, Upper
8	1-807513	2	Bolt-CARR	18	323-10	1	Screw-HH
9	1-603175	1	Knob-Ball	19	32128-21	4	Nut-HF
10	110-5547	1	Lever-Control	20	3234-11	4	Screw-HHF
11	119-1823	1	Cable-Control, Throttle	21	104-8301	1	Nut-Flange, NI
				22	1-303160	1	Spring-Compression
				24	1-303287	2	Tie-Cable

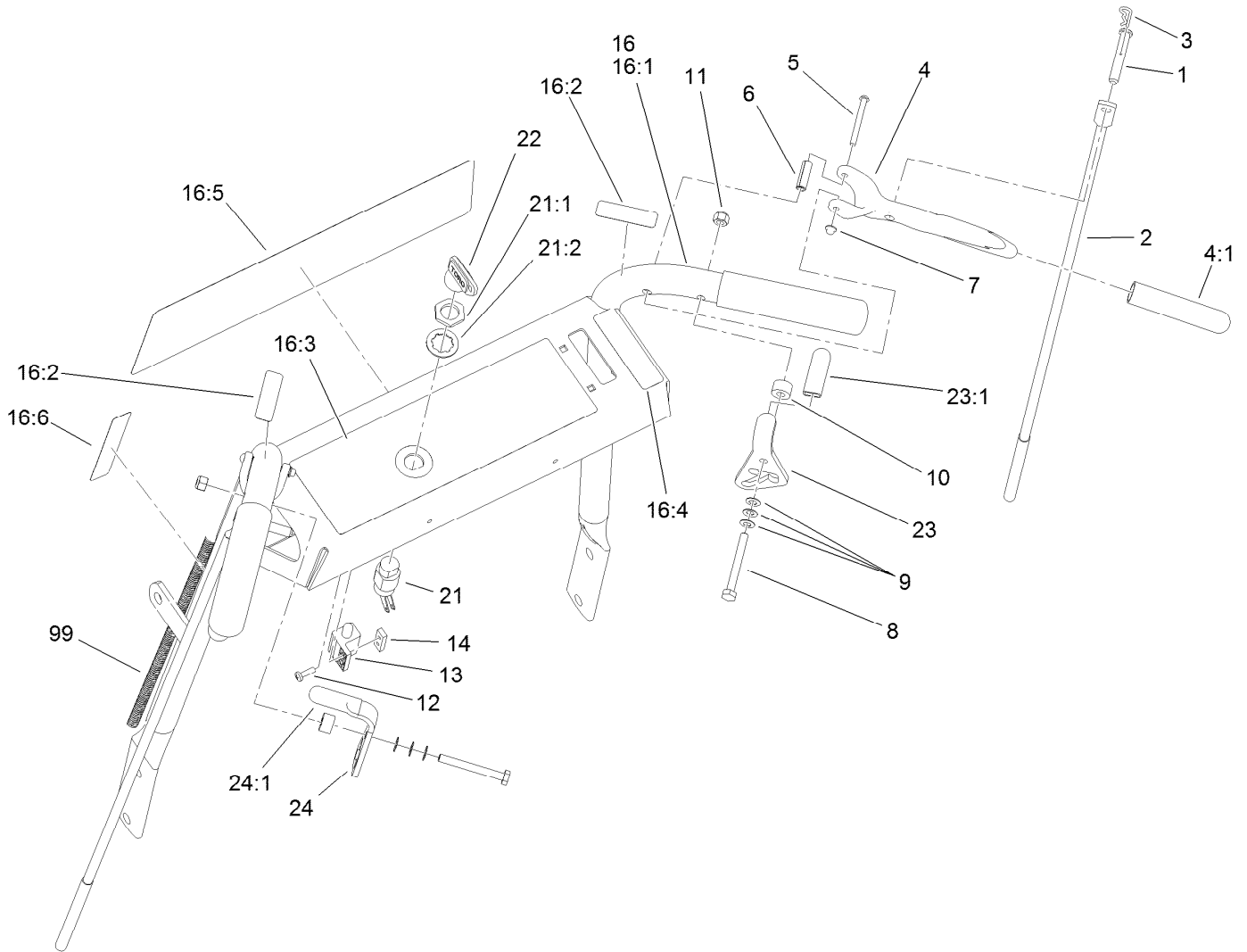

Handle Assembly

Ref.	Part Number	Qty.	Description	Ref.	Part Number	Qty.	Description
1	1-808286	2	Pin-Clevis	16:1		1	Pistol Grip Handle ASM ●
2	1-323359	2	Linkage-Wheel, Drive	16:2	130-8371	2	Decal-Lock, Neutral
3	1-806003	2	Pin-Cotter, Hair	16:3	130-8373	1	Decal-Warning
4	1-302006	2	Drive Lever ASM	16:4	106-2733	1	Decal-Throttle
4:1	1-303021	1	Grip-Lever, Drive	16:5	110-6917	1	Decal
5	1-808250	2	Pin-Lever, Drive	16:6	95-5537	1	Decal-Engage, Deck
6	1-806340	2	Pin-Roll	21	29-5560	1	Switch-On / Off
7	1-803001	2	Nut	21:1	218-461	1	Nut-HH
8	321-18	2	Screw-HH	21:2	3254-5	1	Washer-Tooth, Internal
9	1-303435	6	Washer-Spring	22	63-8360	1	Key-Ignition
10	1-323549	2	Spacer	23	1-324280	1	RH Thumb Latch ASM
11	3296-42	2	Nut-Lock, NI	23:1	1-303019	1	Grip-Latch
12	3290-500	2	Screw-PPH	24	1-324279	1	LH Thumb Latch ASM
13	1-513051	1	Switch-Open, Normally	24:1	1-303019	1	Grip-Latch
14	1-633181	1	Plate-Tapped	99	116-2661	1	Harness-Wire
16	119-3638	1	Handle ASM				

● Not serviced separately

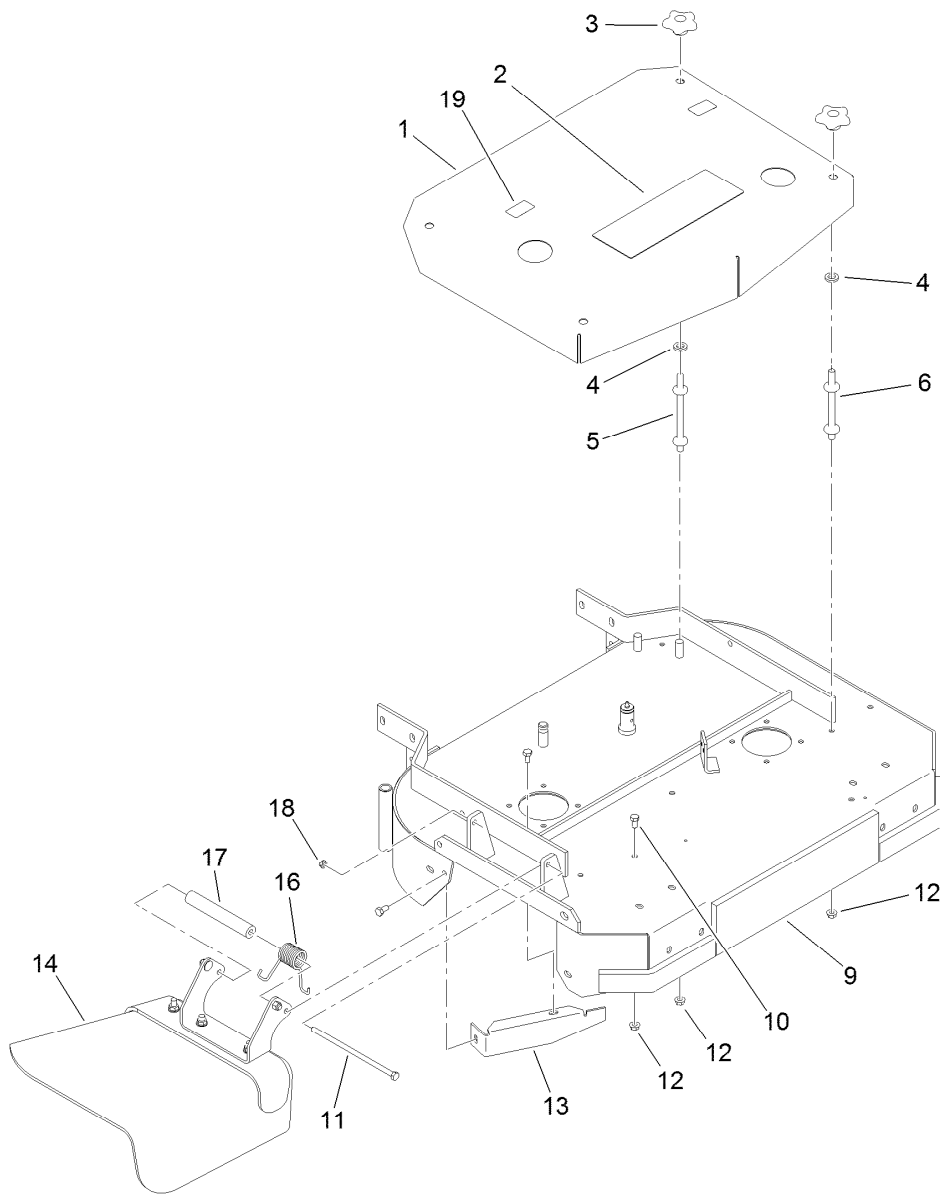

Deck and Shield Assembly

<i>Ref.</i>	<i>Part Number</i>	<i>Qty.</i>	<i>Description</i>	<i>Ref.</i>	<i>Part Number</i>	<i>Qty.</i>	<i>Description</i>
1	1-322149-01	1	Shield ASM	11	322-50	1	Screw-HH
2	106-0710	1	Decal	12	32128-20	11	Nut-HF
3	106-4161	4	Knob-Handle	13	116-1730-01	1	Baffle-Dogleg
4	1-323417	4	Washer	14	119-6529	1	Deflector ASM
5	1-303536	2	Stud-Shield, Belt (Long)	16	108-4052	1	Spring-Torsion
6	1-303537	2	Stud-Shield, Belt (Short)	17	105-4622	1	Spacer
9	110-6901	1	32 Inch Deck ASM	18	3296-47	1	Nut-Lock, NI
10	322-2	7	Screw-HH	19	106-5517	2	Decal-Warning, Hot Surface

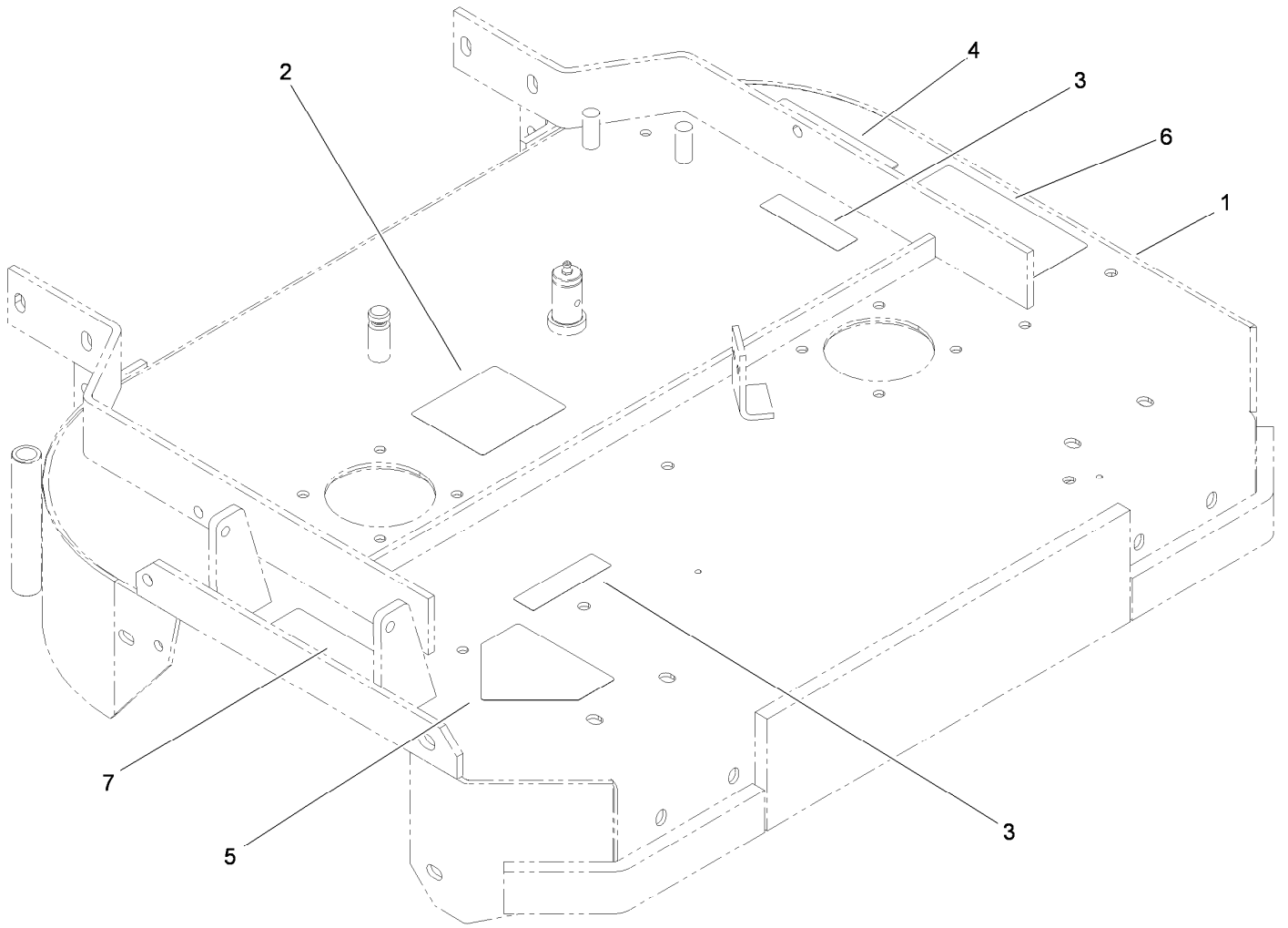

Deck Decal Assembly No. 110-6901

<i>Ref.</i>	<i>Part Number</i>	<i>Qty.</i>	<i>Description</i>
1		1	Deck ●
2	98-3296	1	Decal-Routing, Belt
3	112-9028	2	Decal-Cover Missing
4	98-5130	1	Decal-Torque, Bolt
5	112-8760	1	Decal-Danger
6	93-7010	1	Decal-Danger
7	121-6049	1	Decal-Danger

● Not serviced separately

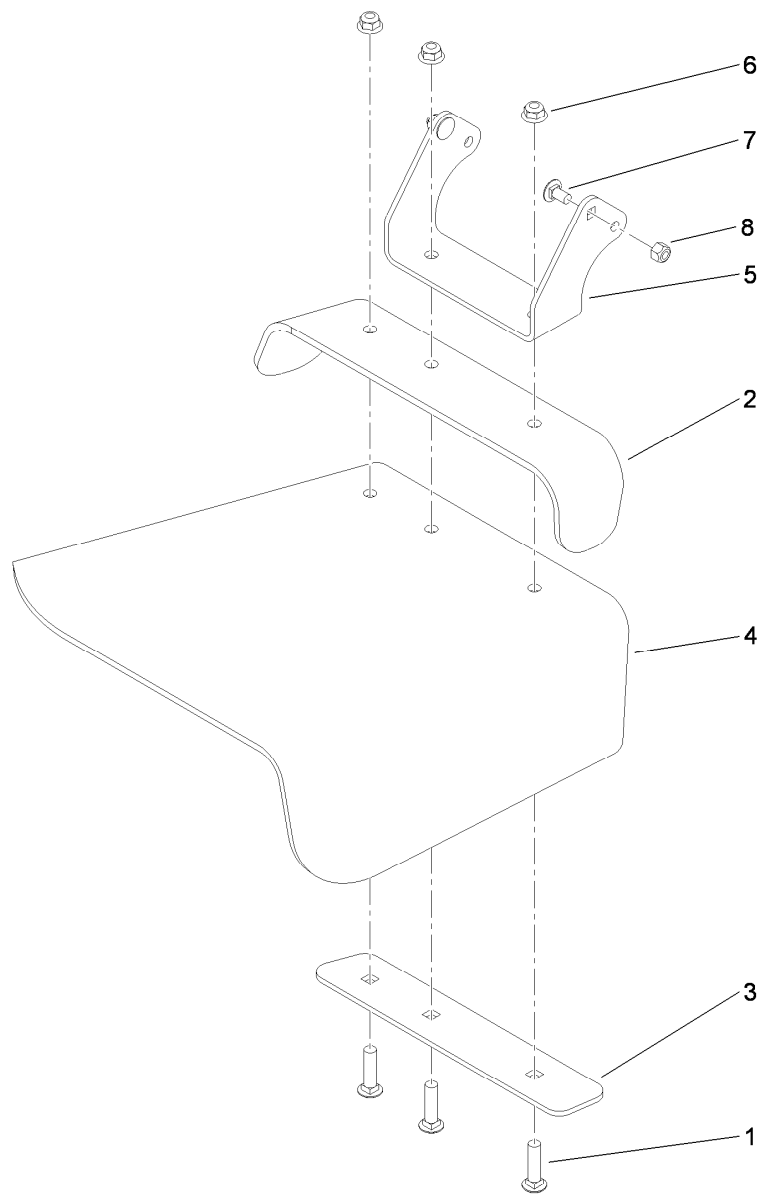

Deflector Assembly No. 119-6529

<i>Ref.</i>	<i>Part Number</i>	<i>Qty.</i>	<i>Description</i>
1	3231-4	3	Screw-CARR
2	107-4138-01	1	Strap-Deflector, Top
3	107-4139-01	1	Strap-Discharge
4	107-4137	1	Deflector-Rubber
5	119-6532-01	1	Bracket-Mounting, Deflector
6	104-8301	3	Nut-Flange, NI
7	3230-18	2	Screw-CARR
8	3296-29	2	Nut-Lock, NI

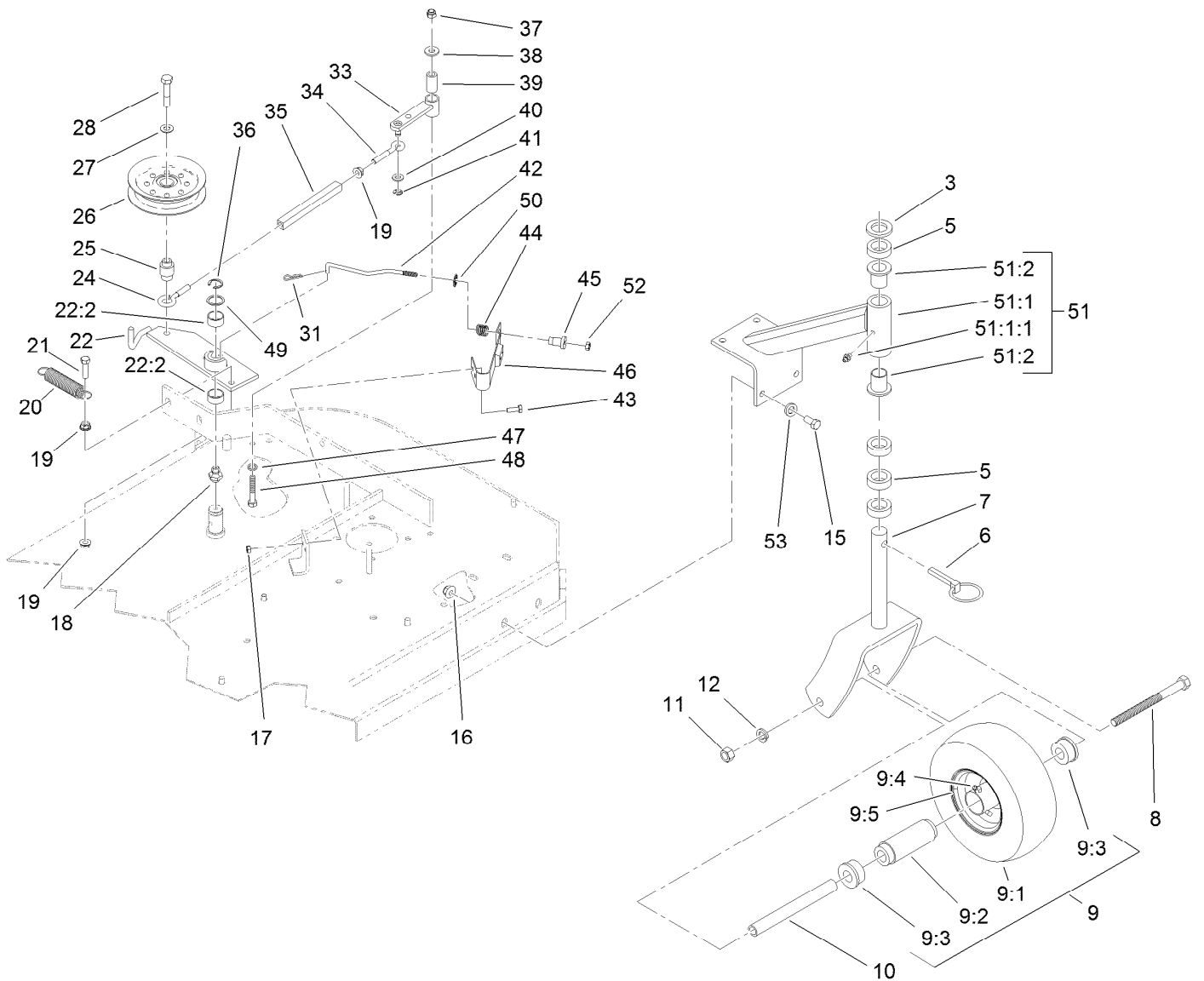

Idler Arm and Caster Wheel Assembly

Ref.	Part Number	Qty.	Description	Ref.	Part Number	Qty.	Description
3	1-513338	2	Washer-Flat	19	32128-20	3	Nut-HF
5	1-303314	8	Spacer-Caster	20	1-323071	1	Spring-Extension
6	1-809020	2	Pin	21	116-3515	1	Screw-HH, Special
7	116-7942-01	2	Fork-Caster	22	103-3600	1	Idler Arm ASM
8	325-20	2	Screw-HH	22:2	1-323729	2	Sleeve-Bearing
9	130-4557	2	Wheel And Tire ASM	24	1-303348	1	Eyebolt-Thread, LH
9:1		1	Tire ●	25	1-303434	1	Bushing-Engagement
9:2	1-513809	1	Bearing	26	116-3626	1	Pulley-Idler
9:3	1-513810	2	Bushing	27	98-5975	1	Washer-Belleville
9:4	302-61	1	Fitting-Grease	28	702809	1	Screw-HH
9:5		1	Wheel ●	31	1-806003	1	Pin-Cotter, Hair
10	1-513547	2	Spacer	33	1-322235	1	Arm-Assist
11	3217-9	2	Nut-HH	34	1-303238	1	Eyebolt-Thread, RH
12	3253-7	2	Washer-Lock	35	1-303236	1	Body-Turnbuckle
15	323-6	8	Screw-HH	36	32151-103	1	Ring-Retaining, EXT
16	104-8301	8	Nut-Flange, NI	37	3296-29	1	Nut-Lock, NI
17	3296-42	2	Nut-Lock, NI	38	3256-3	1	Washer-Flat
18	302-40	1	Fitting-Grease, 90 DEG	39	1-403179	1	Tube-Pivot

● Not serviced separately

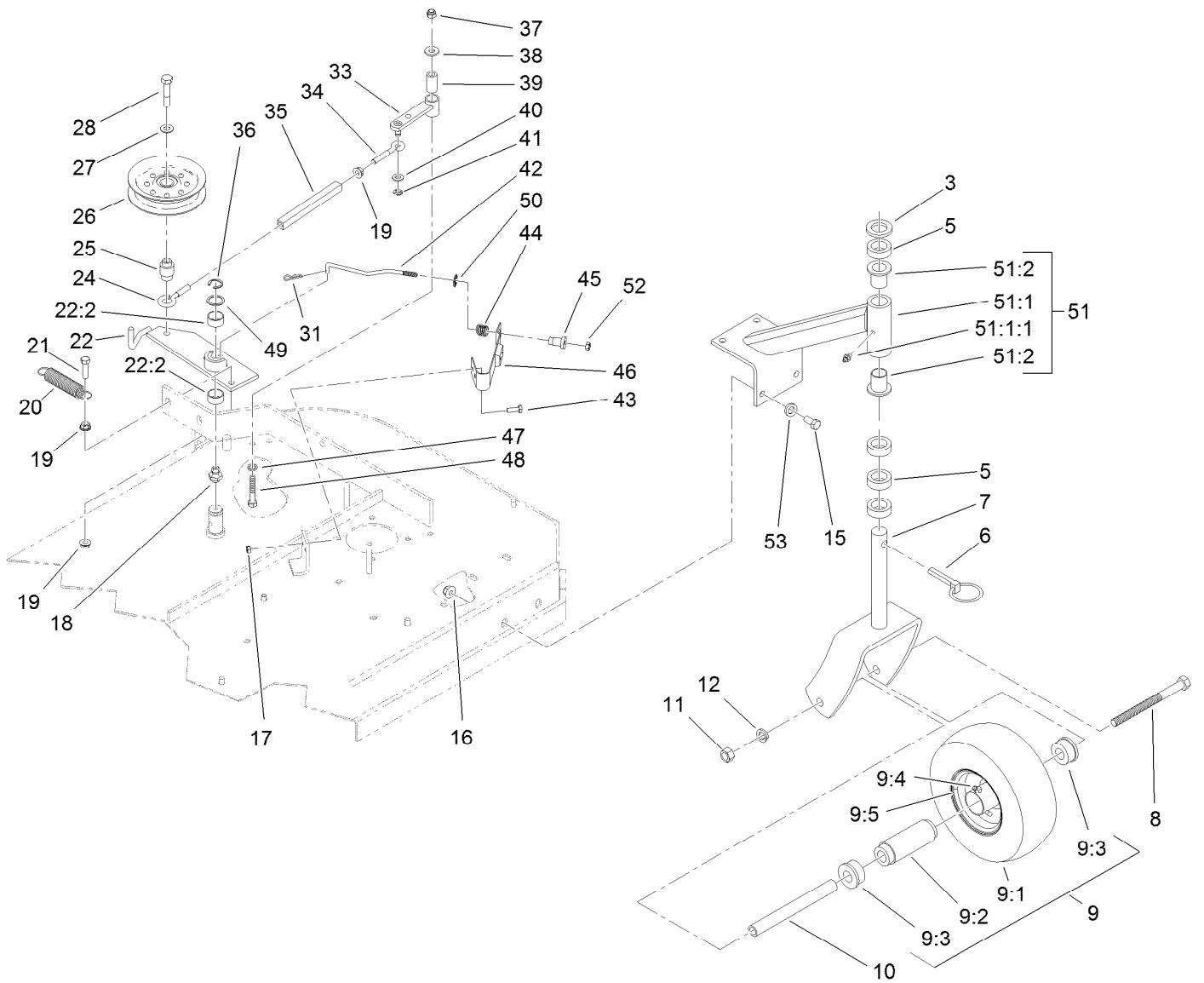

Idler Arm and Caster Wheel Assembly (continued)

Ref.	Part Number	Qty.	Description	Ref.	Part Number	Qty.	Description
40	3256-23	1	Washer-Flat	49	1-303352	1	Washer-Spindle
41	32120-35	1	Ring-Retaining, EXT	50	1-323748	1	Ring-Push On
42	1-323718	1	Rod-Brake	51	1-302203	2	Support ASM
43	321-4	2	Screw-HH	51:1		1	Support-Caster ●
44	1-323747	1	Spring-Compression	51:1:1	302-52	1	Fitting-Grease
45	1-323746	1	Spacer-Flanged	51:2	1-303514	2	Bearing-Flanged
46	1-324372	1	Pad And Spring ASM	52	3296-56	1	Nut-Lock, NI
47	1-303334	1	Washer-Spring	53	3256-24	8	Washer-Flat
48	322-10	1	Screw-HH				

● Not serviced separately

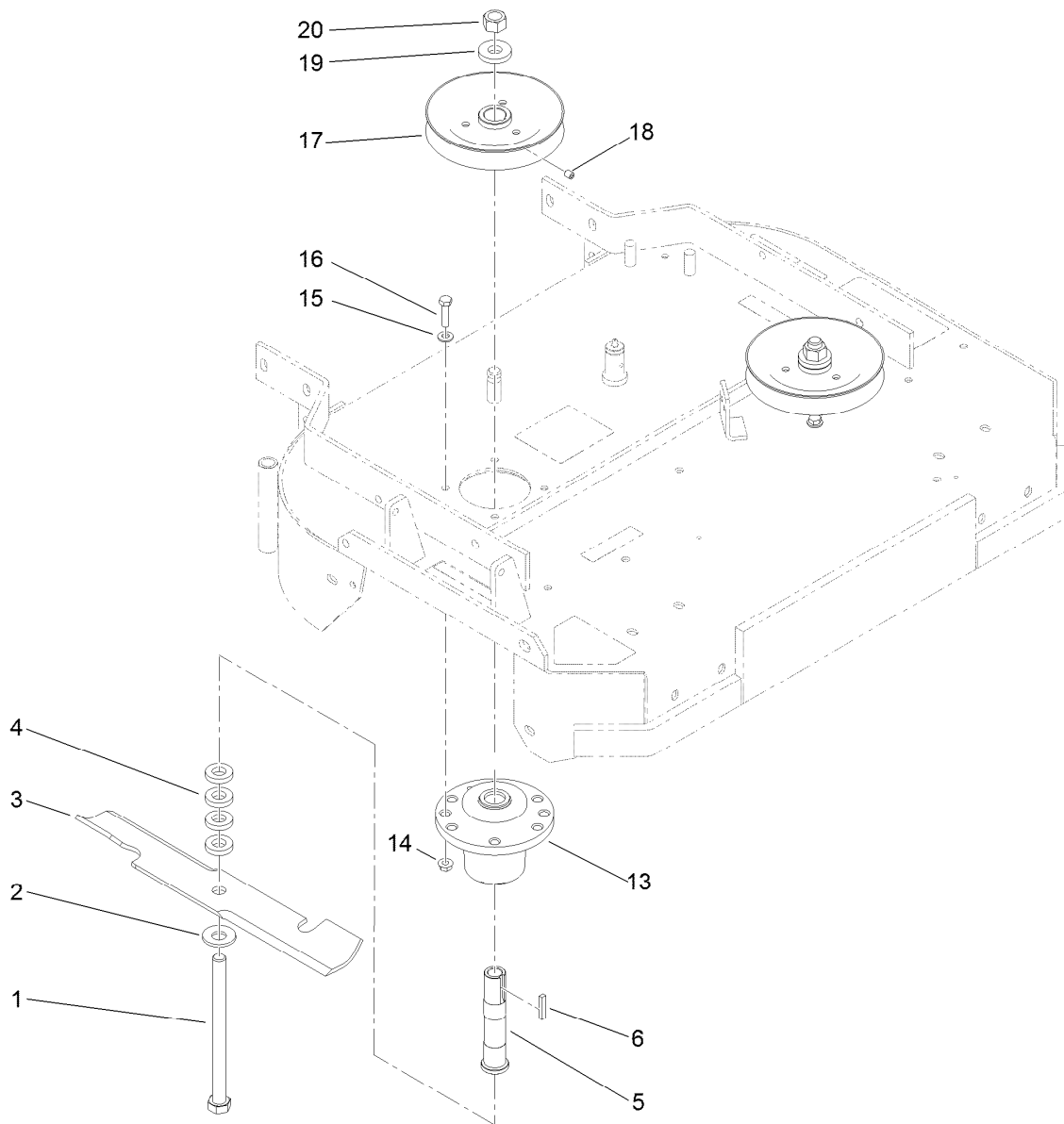

Spindle and Blade Assembly

<i>Ref.</i>	<i>Part Number</i>	<i>Qty.</i>	<i>Description</i>
1	1-800861	2	Screw-Cap, HH
2	1-513208	2	Washer-Spring
3	103-2527	2	Blade-Notched
4	1-323539	8	Spacer
5	1-323529	2	Tube-Spindle, Short
6	1-807267	2	Key
13	107-4065	2	Cutter Housing ASM
14	32128-20	8	Nut-HF
15	1-303334	8	Washer-Spring
16	322-6	8	Screw-HH
17	1-403183	2	Sheave
18	3246-18	2	Setscrew
19	1-323339	2	Washer-Retainer, Sheave
20	3219-6	2	Nut-Hex

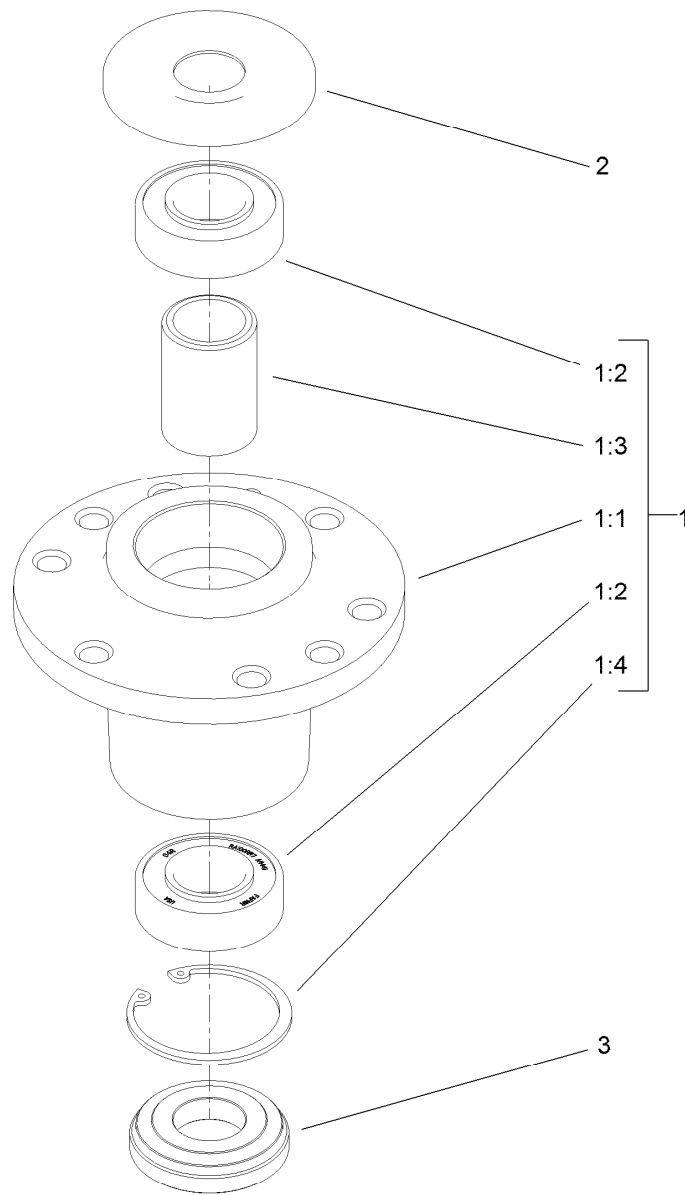

Cutter Housing Assembly No. 107-4065

<i>Ref.</i>	<i>Part Number</i>	<i>Qty.</i>	<i>Description</i>
1		1	Cutter Housing ASM ●
1:1	103-7975	1	Housing-Spindle
1:2	103-2477	2	Bearing-Jackshaft
1:3	103-2534	1	Spacer-Bearing
1:4	32120-8	1	Ring-Snap
2	103-1330	1	Guard-Bearing, Top
3	103-2535	1	Spacer-Guard, Bottom

● Not serviced separately

Attachments and Accessories

For 30632 Commercial Walk-Behind Mower Fixed Deck, Pistol Grip, Gear Drive with 32in Cutting Unit

Product Name	Model/Part
Soft Bag (3 Bushel).....	30198
32in Recycler Kit.....	110-4915
Atomic Blade and Decal Assembly	104-8595
32in and 48in Fixed Deck Low Lift Blades.....	103-2507
Blade-Notched.....	103-2527
Blade-Atomic, 16.25in (6 Pack)	110-0407
Blade-16.25 inch (6 Pack).....	108-1119
Weight Kit	107-4100
Filter-fuel.....	120-2235
Spark Plug	92-2153
Oil Filter	119-5852
Element-Filter, Air	120-7447
Oil-Synthetic, All Season	117-0066
Toro 4-cycle Sae 30 Oil (32oz Bottle).....	38903

Notes:

Notes:

Notes:



Count on it.