



Count on it.

Parts Catalog

**Commercial Walk-Behind Mower
Fixed Deck, Pistol Grip, Hydro Drive with
36in TURBO FORCE® Cutting Unit**

Model No. 39934—Serial No. 315000001 and Up



Ordering Replacement Parts

To order replacement parts, please supply the part number, the quantity, and the description of each part desired.

Understanding Reference Numbers

Each identified part in an illustration has a reference number. The reference number for a part also appears in the parts list, along with other information about the part.

This catalog uses two special reference number formats, one to indicate parts in a service assembly and another to indicate the quantity of a given part in an illustration.

Service Assembly Reference Numbers

Parts in service assemblies have reference numbers in the form a:b. The a represents the reference number of the entire service assembly and the b represents a sequential number unique to each part within the service assembly.

For example, a wheel assembly might be identified by reference number 6, the tire by 6:1, the valve by 6:2, and the wheel by 6:3. When you order the assembly identified by reference number 6, you receive all parts identified by reference numbers 6:1, 6:2, and 6:3. However, you may also order any part individually. Reference numbers of this type appear in illustration and in parts lists.

Reference Numbers Indicating Quantity

In an illustration, if a reference number indicates more than one part, the reference number has the form nX y. The n represents the quantity of the part, the X is the multiplication symbol, and the y represents the reference number.

For example, in an illustration, the reference number 2X 37 means that two of the parts identified by reference number 37 are indicated.

List of Abbreviations

AR: as required

ASM: assembly

BBC: blade brake control

BHTF: button head thread forming

CARR: carriage

CCW: counter clockwise

CW: clockwise

DEG: degrees

DPA: Dual Point Adjustment

ECM: electronic control module

EXT: external

FH: flat head

GA: gauge

HD: heavy-duty

HF: hex flange

HH: hex head

HHF: hex head flange

HHFTF: hex head flange thread forming

HJ: hex jam

HLH: hex lag head

HOC: height-of-cut

HP: high pressure

HSBH: hex socket button head

HSFH: hex socket flat head

HSH: hex socket head

HWH: hex washer head

HWHTF: hex washer head thread forming

HYD: hydraulic

LH: left hand

LP: low pressure

LPG: Liquefied Petroleum Gas

NI: nylon insert

NPTF: national pipe thread fine

PFH: phillips flat head

PPH: phillips pan head

PPHTF: phillips pan head thread forming

PRH: phillips round head

PTH: phillips truss head

PTO: power-take-off

RH: right hand

ROPS: roll-over protection system

RRB: rear roller brush

SFH: slotted fillister head

SHH: slotted hex head

SHWH: slotted hex washer head

SPH: slotted pan head

SQH: square head

SRH: slotted round head

STD: standard

TAP: self tapping

TTH: torx truss head

Contents

Engine and Exhaust Assembly.....	4
Fuel System Assembly	6
Pump Drive and Engine Pulley Assembly	7
Hydraulic Wheel Motor Assembly No. 1-603718.....	8
LH Hydraulic Pump Assembly No. 116-0942.....	9
RH Hydraulic Pump Assembly No. 116-0943	10
Parking Brake Assembly.....	11
Deck Engagement Assembly	12
Hydraulic System Assembly	13
Lower Control Assembly.....	14
Upper Control Assembly.....	16
Handle Assembly No. 119-6538	18
Drive Lever Assembly	19
Deck Assembly.....	20
Deck Decal Assembly No. 110-4907.....	21
Deflector Assembly No. 119-6530.....	22
Sheave, Spindle and Blade Assembly	23
Idler Assembly	24
Caster Assembly	25
Attachments and Accessories	26

Engine and Exhaust Assembly

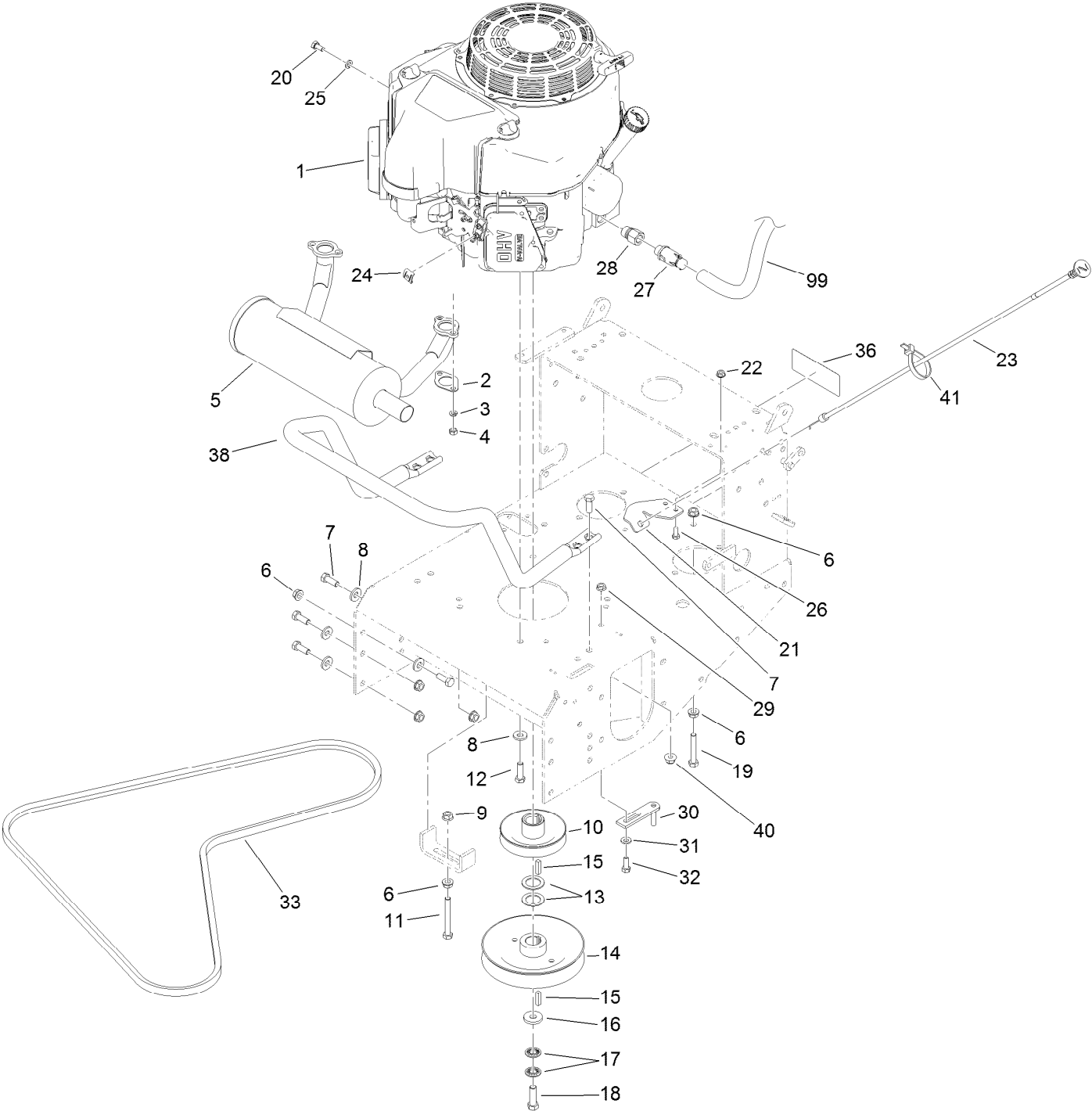

Engine and Exhaust Assembly (continued)

<i>Ref.</i>	<i>Part Number</i>	<i>Qty.</i>	<i>Description</i>	<i>Ref.</i>	<i>Part Number</i>	<i>Qty.</i>	<i>Description</i>
1		1	Engine-Kawasaki, Fs481V-As06 ●■	20	33114-016	1	Screw-HH
2	1-653313	2	Gasket-Exhaust	21	103-1797-01	1	Bracket-Cable, Choke
3	114-3550	4	Washer-Lock, Spring	22	32128-33	2	Nut-HF
4	114-3549	4	Nut	23	103-1796	1	Cable-Choke
5	116-3734	1	Muffler-Horizontal, Offset	24	81-1690	1	Clamp-Cable
6	3290-357	11	Nut-HHF, Whiz	25	3253-4	1	Washer-Lock
7	323-6	12	Screw-HH	26	321-3	2	Screw-HH
8	98-5975	12	Washer-Belleville	27	120-4321	1	Valve-Drain, Oil
9	32128-21	1	Nut-HF	28	103-1966	1	Adapter
10	1-653035	1	Pulley	29	32128-20	1	Nut-HF
11	323-14	1	Screw-HH	30	1-322110	1	Guide-Belt
12	323-7	4	Screw-HH	31	1-303334	1	Washer-Spring
13	1-523157	2	Washer-Spacer	32	322-4	1	Screw-HH
14	110-4891	1	Pulley	33	108-6644	1	Belt-V
15	1-807259	2	Key	36	126-1400	1	Decal-Warning, Sulky
16	1-373034	1	Washer	38	116-6278-03	1	Guard-Muffler
17	1-603610	2	Washer-Spring	40	104-8301	4	Nut-Flange, NI
18	116-3702	1	Screw-HH	41	1-303287	1	Tie-Cable
19	323-11	1	Screw-HH	99	103-1964	1	Hose-Drain, Oil

● Not serviced separately

■ Obtain parts from www.kawpowerepc.com

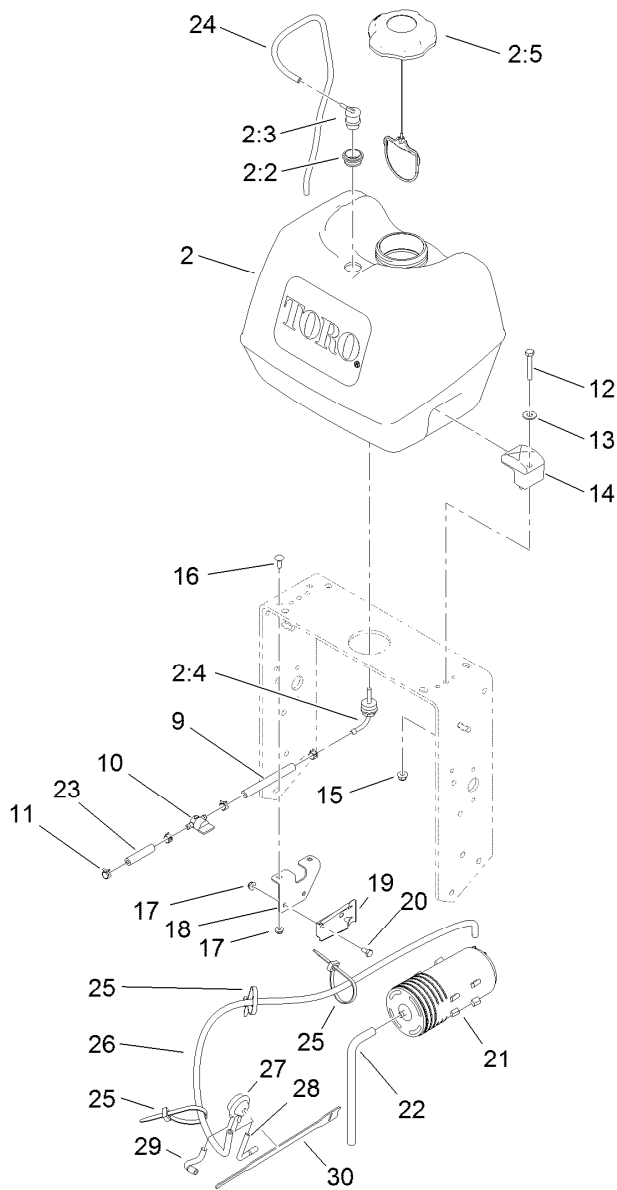

Fuel System Assembly

<i>Ref.</i>	<i>Part Number</i>	<i>Qty.</i>	<i>Description</i>	<i>Ref.</i>	<i>Part Number</i>	<i>Qty.</i>	<i>Description</i>
2	126-1526	1	Fuel Tank ASM	18	115-4486-01	1	Bracket-Canister, Carbon
2:2	114-0284	1	Grommet	19	114-0292	1	Bracket-Canister, Carbon
2:3	119-3547	1	Valve-Vent, Fuel	20	321-2	2	Screw-HH
2:4	103-2605	1	Fitting-Fuel, Bulkhead	21	117-1221	1	Canister-Carbon, 800Cc
2:5	120-5461	1	Cap-Fuel, Ratcheting	22	115-0962	1	Hose-Vent, Canister
9	109-0650	1	Hose-Fuel	23	99-9415	1	Hose-Fuel
10	1-603770	1	Valve-Fuel	24	114-0286	1	Hose-Vent
11	2412-98	4	Clamp-Hose	25	3290-378	3	Tie-Cable
12	322-10	2	Screw-HH	26	116-2231	1	Hose-Vent, Formed
13	3256-3	2	Washer-Flat	27	116-2232	1	Valve-Control, Vacuum
14	107-4543	2	Clamp	28	119-8501	1	Hose-Vent, Formed
15	104-8300	2	Nut-Flange, NI	29	119-8502	1	Hose-Vent, Formed
16	3229-1	2	Bolt-CARR	30	116-2469	1	Strap-Velcro, Cable Tie
17	104-7201	4	Nut-HF				

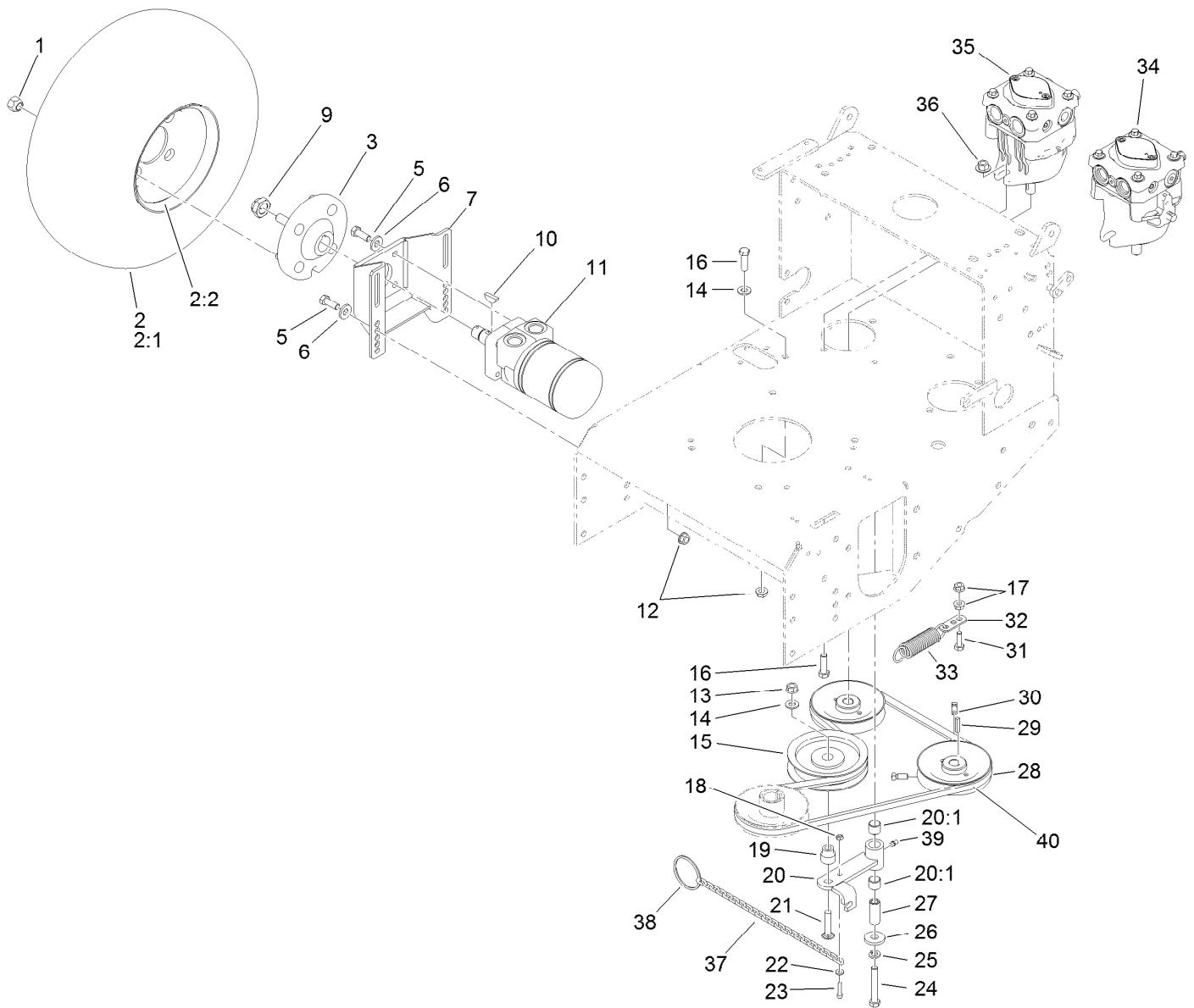

Pump Drive and Engine Pulley Assembly

Ref.	Part Number	Qty.	Description
1	242-50	8	Nut-Lug
2	130-4553	2	Wheel And Tire ASM
2:1	1-413474	1	Tire-Turfmaster
2:2	130-4567	1	Rim-Wheel, Gray
3	112-9049	2	Wheel Hub ASM
5	323-6	16	Screw-HH
6	98-5975	16	Washer-Belleville
7	103-2289-01	2	Mount-Motor
9	116-2839	2	Nut-Lock
10	1-807019	2	Key-Woodruff
11	1-603718	2	HYD Motor ASM
12	3290-357	9	Nut-HHF, Whiz
13	32128-21	1	Nut-HF
14	3256-24	2	Washer-Flat
15	109-4077	1	Pulley-Idler, Flat
16	323-7	5	Screw-HH
17	32128-20	2	Nut-HF
18	3296-2	1	Nut-Lock, NI
19	1-603496	1	Bushing-Idler
20	1-602521	1	Idler Arm ASM
20:1	103-4681	2	Sleeve-Bearing

Ref.	Part Number	Qty.	Description
21	3231-29	1	Screw-CARR
22	3256-14	1	Washer-Flat
23	1-809069	1	Screw-HSH
24	323-12	1	Screw-HH
25	3253-21	1	Washer-Lock
26	1-373034	1	Washer
27	1-603044	1	Bushing
28	1-413010	2	Sheave ASM
29	1-807272	2	Key
30	120-6474	4	Screw-Set, SQH
31	322-5	1	Screw-HH
32	1-603801	1	Anchor-Spring
33	1-603402	1	Spring-Extension
34	116-0942	1	LH HYD Pump ASM
35	116-0943	1	RH HYD Pump ASM
36	32128-43	4	Nut-Flange
37	1-323365	1	Chain-Link, Twist
38	1-323366	1	Ring-Split
39	302-19	1	Fitting-Grease
40	106-2740	1	V-Belt

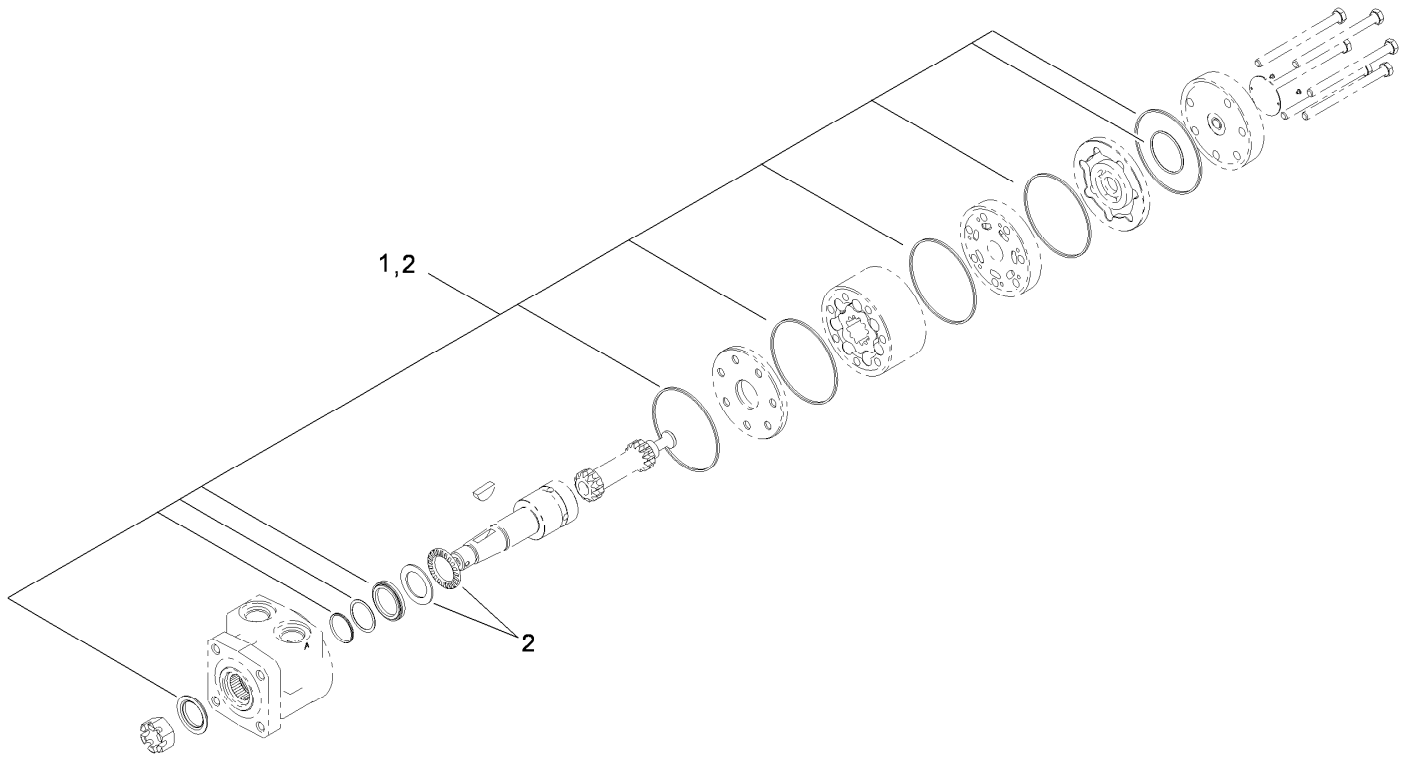

Hydraulic Wheel Motor Assembly No. 1-603718

<i>Ref.</i>	<i>Part Number</i>	<i>Qty.</i>	<i>Description</i>
1	1-000119	1	Seal Kit
2	1-000138	1	Bearing And Seal Kit

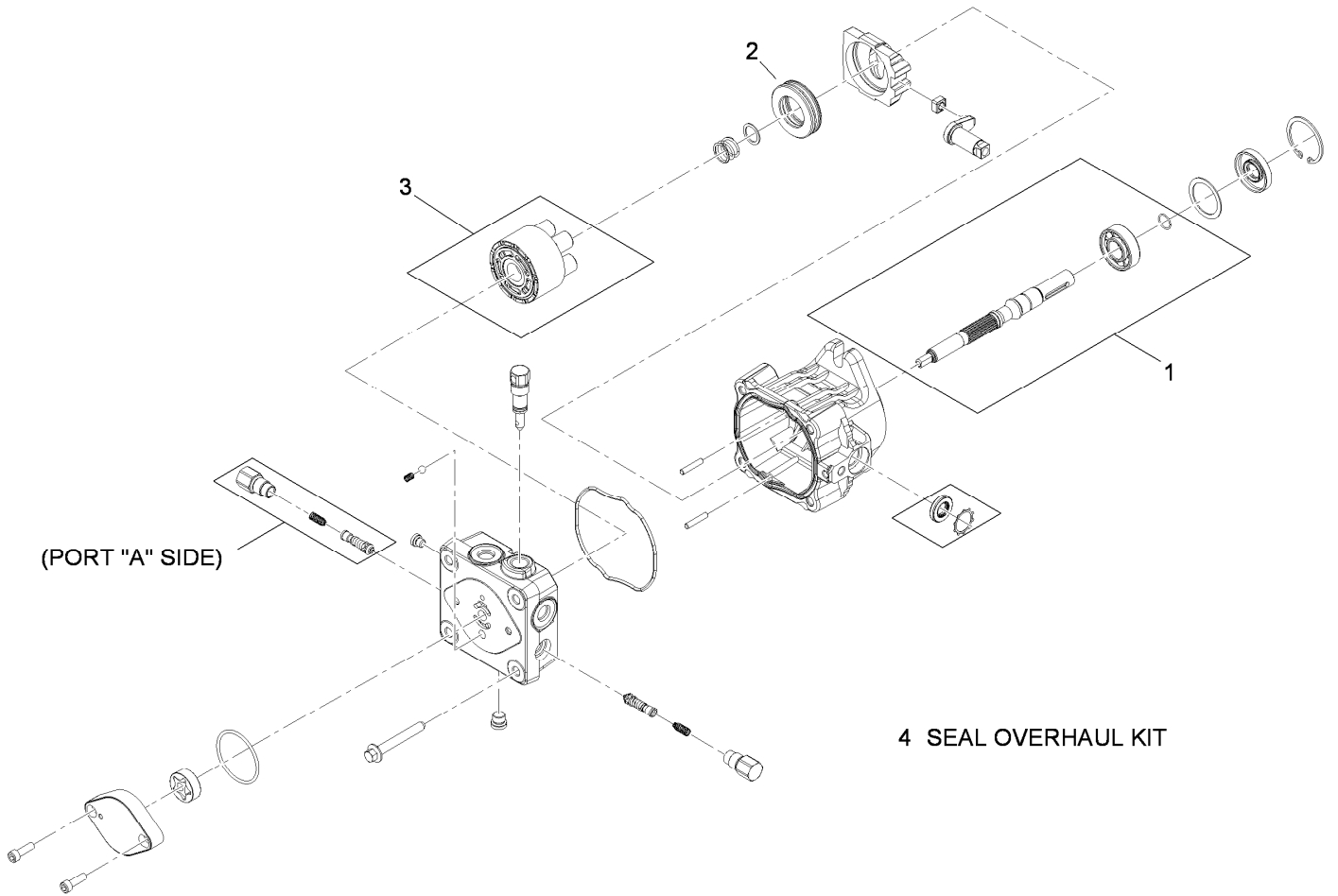

LH Hydraulic Pump Assembly No. 116-0942

<i>Ref.</i>	<i>Part Number</i>	<i>Qty.</i>	<i>Description</i>
1	103-2664	1	Input Shaft Kit
2	94-6922	1	Bearing-Thrust
3	103-2666	1	Cylinder Block Kit
4	105-6184	1	Seal Overhaul Kit

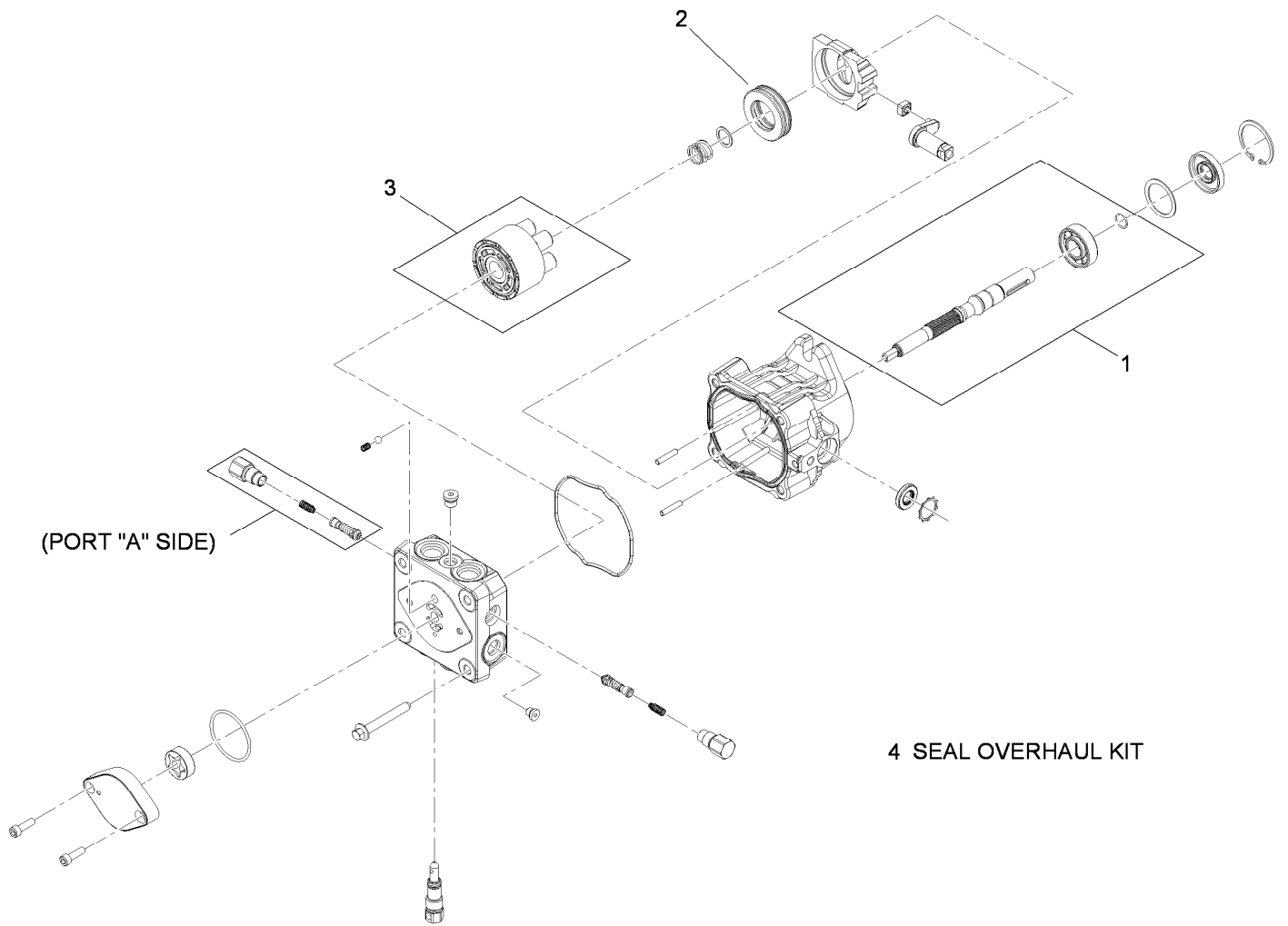

4 SEAL OVERHAUL KIT

RH Hydraulic Pump Assembly No. 116-0943

<i>Ref.</i>	<i>Part Number</i>	<i>Qty.</i>	<i>Description</i>
1	103-2664	1	Input Shaft Kit
2	94-6922	1	Bearing-Thrust
3	103-2666	1	Cylinder Block Kit
4	105-6184	1	Seal Overhaul Kit

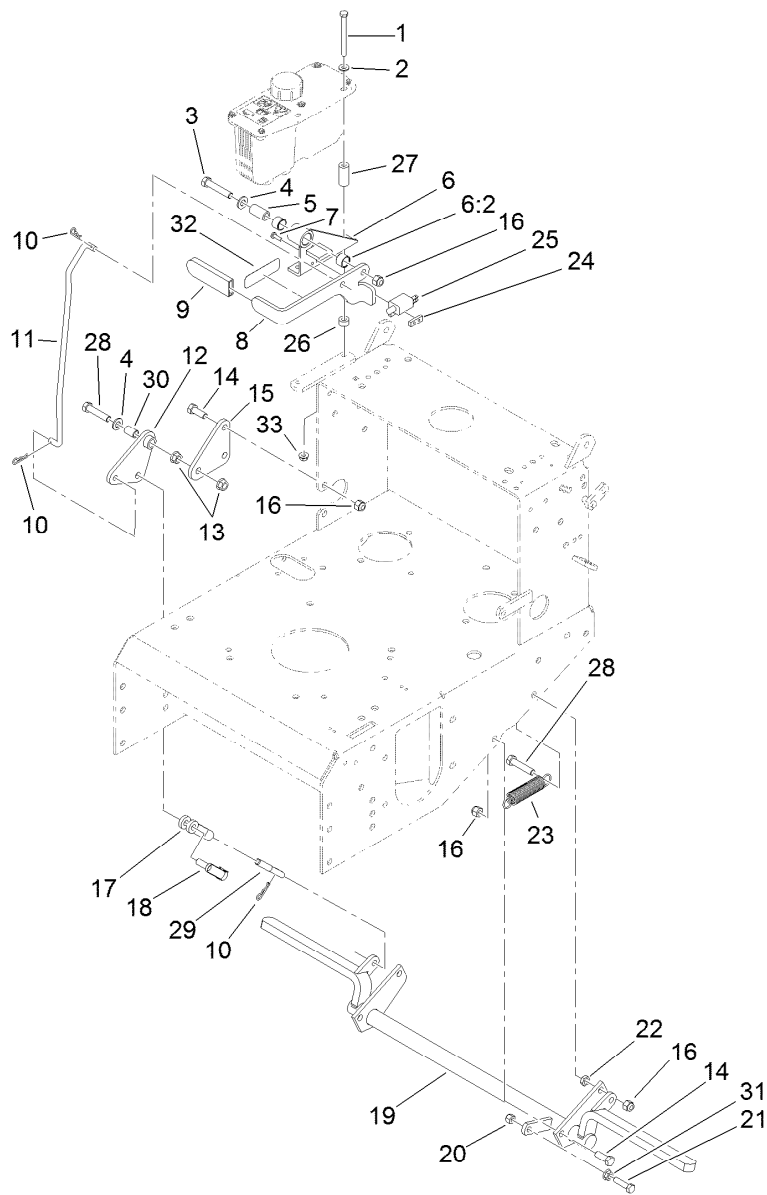

Parking Brake Assembly

<i>Ref.</i>	<i>Part Number</i>	<i>Qty.</i>	<i>Description</i>	<i>Ref.</i>	<i>Part Number</i>	<i>Qty.</i>	<i>Description</i>
1	321-23	2	Screw-HH	17	1-633131	1	Yoke-Linkage, Brake
2	3256-22	2	Washer-Flat	18	103-2399	1	Pin-Spring, Clevis
3	323-10	1	Screw-HH	19	126-1599	1	Shaft-Cross, Brake
4	3256-24	2	Washer-Flat	20	3296-29	1	Nut-Lock, NI
5	1-413344	1	Bushing-Pivot	21	116-3515	1	Screw-HH, Special
6	1-414504	1	Bracket ASM	22	3218-3	1	Nut-Jam
6:2	1-413347	2	Sleeve-Bushing	23	1-323161	1	Spring-Idler
7	3290-500	2	Screw-PPH	24	1-633181	1	Plate-Tapped
8	116-1725-03	1	Lever-Brake, Park	25	1-513051	1	Switch-Open, Normally
9	1-303020	1	Grip-Lever	26	1-323549	2	Spacer
10	1-806003	3	Pin-Cotter, Hair	27	103-2191	2	Spacer
11	1-413496	1	Linkage-Upper	28	323-9	2	Screw-HH
12	1-414508	1	Bellcrank ASM	29	1-413489	1	Linkage-Lower
13	32128-21	2	Nut-HF	30	1-303548	1	Bushing-Plastic
14	323-6	5	Screw-HH	31	32128-20	1	Nut-HF
15	1-413497	1	Bellcrank	32	130-8376	1	Decal-Brake, Parking
16	3296-39	7	Nut-Lock, NI	33	32128-33	2	Nut-HF

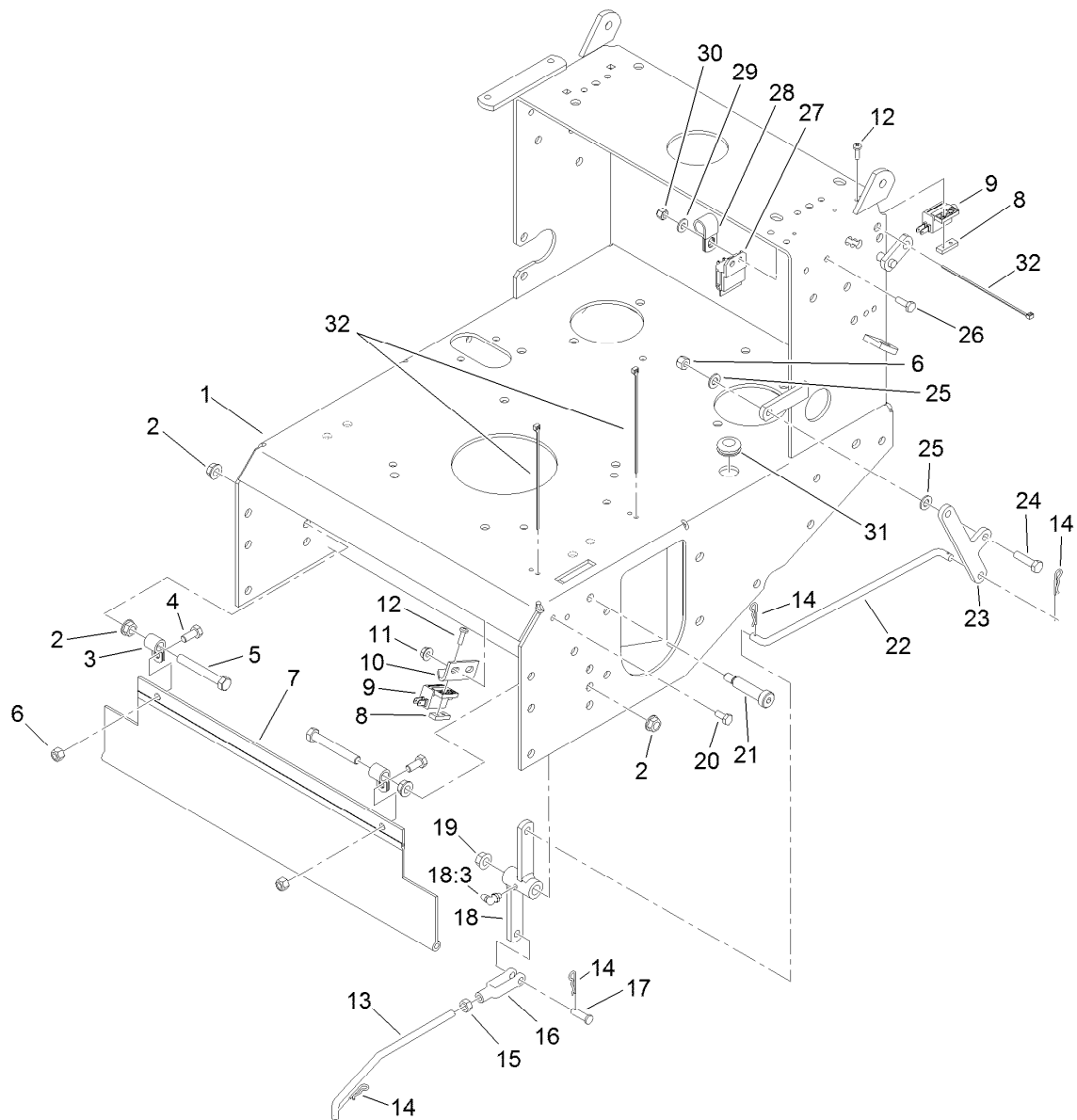

Deck Engagement Assembly

<i>Ref.</i>	<i>Part Number</i>	<i>Qty.</i>	<i>Description</i>	<i>Ref.</i>	<i>Part Number</i>	<i>Qty.</i>	<i>Description</i>
1	116-6086-01	1	Frame	18	1-322108	1	Bellcrank ASM
2	3290-357	4	Nut-HHF, Whiz	18:3	302-40	1	Fitting-Grease, 90 DEG
3	1-413510	2	Clip-Loom	19	32128-21	1	Nut-HF
4	322-3	2	Screw-HH	20	321-3	2	Screw-HH
5	323-13	2	Screw-HH	21	1-809062	1	Screw
6	3296-29	3	Nut-Lock, NI	22	1-323172	1	Linkage-Engage, Blade
7	103-2056	1	Shield-Drag	23	116-1737-01	1	Bellcrank
8	1-633181	2	Plate-Tapped	24	322-6	1	Screw-HH
9	1-513051	2	Switch-Open, Normally	25	3256-23	2	Washer-Flat
10	1-323213	1	Bracket-Switch, Blade	26	321-4	1	Screw-HH
11	32128-33	2	Nut-HF	27	1-323430	1	Module-Interlock
12	3290-500	4	Screw-PPH	28	1-603727	1	Clip-Loom
13	1-323174	1	Arm-Linkage, Assist	29	3256-22	1	Washer-Flat
14	1-806003	4	Pin-Cotter, Hair	30	3296-42	1	Nut-Lock, NI
15	3219-2	1	Nut-Hex	31	1-543296	1	Grommet
16	1-303105	1	Yoke-Adjustable	32	1-303287	3	Tie-Cable
17	1-808280	1	Pin-Clevis				

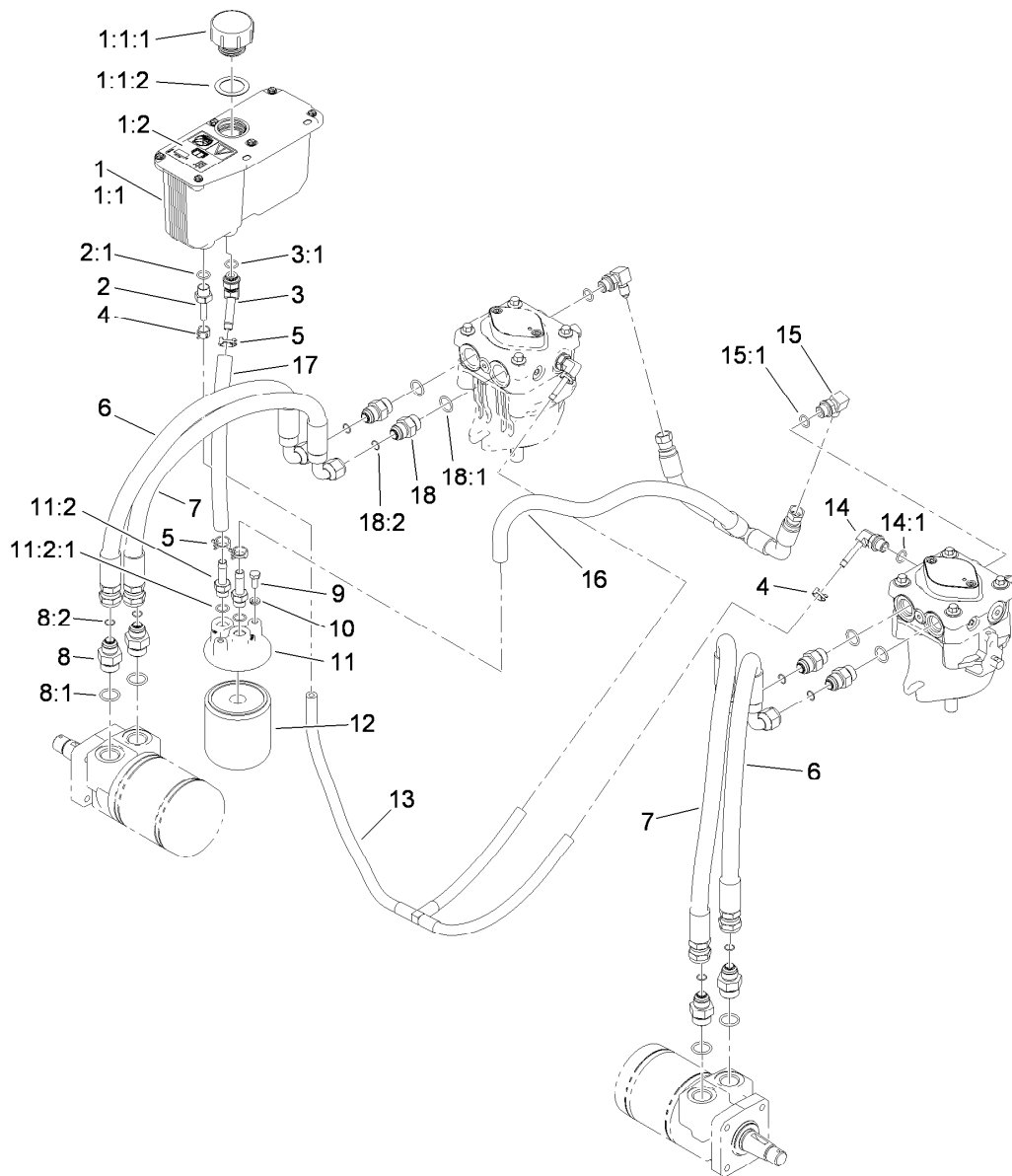

Hydraulic System Assembly

Ref.	Part Number	Qty.	Description
1	107-8433	1	HYD Reservoir ASM
1:1		1	Reservoir-HYD ●
1:1:1	103-1948	1	Cap-Reservoir, HYD
1:1:2	103-1949	1	Gasket-Cap
1:2	115-4212	1	Decal-Warning
2	103-1801	1	Adapter-Straight
2:1	237-42	1	O-Ring
3	103-1807	1	Fitting-Barbed, 45 DEG
3:1	237-42	1	O-Ring
4	103-1716	3	Clamp-Hose
5	103-1988	3	Clamp-Hose
6	119-7827	2	HYD Hose ASM
7	119-7826	2	HYD Hose ASM
8	1-603991	4	Fitting-Straight
8:1	237-80	1	O-Ring
8:2	1-603992	1	O-Ring

Ref.	Part Number	Qty.	Description
9	321-3	2	Screw-HH
10	1-805004	2	Washer-Lock
11	103-2889	1	Filter Head ASM
11:2	103-1912	2	Adapter-Straight
11:2:1	237-42	1	O-Ring
12	1-633750	1	Filter-Oil, HYD
13	116-0918	1	Case Drain Hose ASM
14	103-1799	2	Elbow-90 DEG
14:1	237-42	1	O-Ring
15	103-1802	2	Fitting-HYD, 90 DEG
15:1	1-603921	1	O-Ring
16	116-2123	1	Charge Hose ASM
17	103-2959	1	Hose-Charge
18	1-603990	4	Fitting-Straight
18:1	1-603920	1	O-Ring
18:2	1-603992	1	O-Ring

● Not serviced separately

Lower Control Assembly

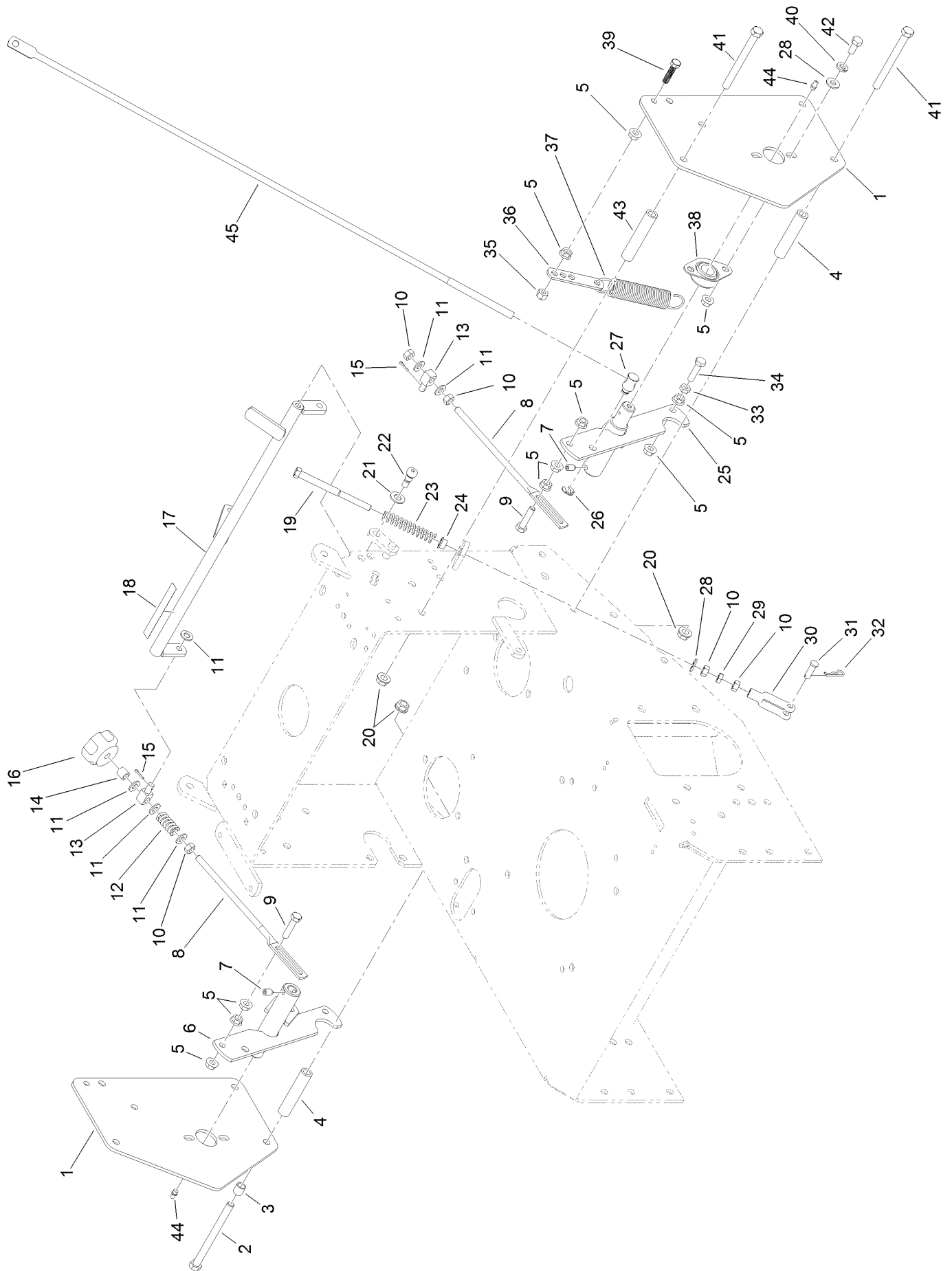

Lower Control Assembly (continued)

<i>Ref.</i>	<i>Part Number</i>	<i>Qty.</i>	<i>Description</i>	<i>Ref.</i>	<i>Part Number</i>	<i>Qty.</i>	<i>Description</i>
1	110-4897-01	2	Shield-Control	24	1-603735	2	Bushing-Flanged
2	323-23	1	Screw-HH	25	103-1190-01	1	Shaft-Control, LH
3	103-1166	1	Spacer-Tube, Pump Link	26	32151-47	2	Ring-Retaining
4	1-323197-01	4	Spacer-Shield	27	103-1235	2	Swivel-Lever, Drive
5	32128-20	18	Nut-HF	28	3256-2	6	Washer-Flat
6	103-4796-01	1	Shaft-Control, RH	29	3220-2	2	Nut-Jam
7	3246-4	2	Screw-Set	30	1-303105	2	Yoke-Adjustable
8	1-413350	2	Link-Control, Speed	31	1-808280	2	Pin-Clevis
9	1-403180	2	Screw-HH	32	1-806003	2	Pin-Cotter, Hair
10	3219-2	7	Nut-Hex	33	3218-2	2	Nut-Jam
11	3256-23	7	Washer-Flat	34	116-3515	2	Screw-HH, Special
12	1-323245	1	Spring-Compression	35	3296-29	2	Nut-Lock, NI
13	1-603676	2	Swivel-Adjustable, Short	36	1-613089	2	Tab-Spring, Extension
14	1-603903	1	Spacer	37	1-603693	2	Spring-Extension
15	3272-5	2	Pin-Cotter	38	1-633102	2	Bearing-Flange, Side
16	103-3060	1	Knob-Tracking	39	1-800016	2	Bolt-TAP, HH
17	1-412203-01	1	Crank-Control, Speed	40	1-805005	4	Washer-Lock
18	130-8375	1	Decal-Tracking	41	323-16	7	Screw-HH
19	1-603737	2	Bolt-Return, Neutral	42	322-3	4	Screw-HH
20	3290-357	8	Nut-HHF, Whiz	43	1-323195-01	4	Spacer-Shield
21	3256-24	2	Washer-Flat	44	302-19	2	Fitting-Grease
22	1-809056	2	Screw-HSH	45	1-413219	2	Rod-Lever, Drive
23	1-603807	2	Spring-Return, Neutral				

Upper Control Assembly

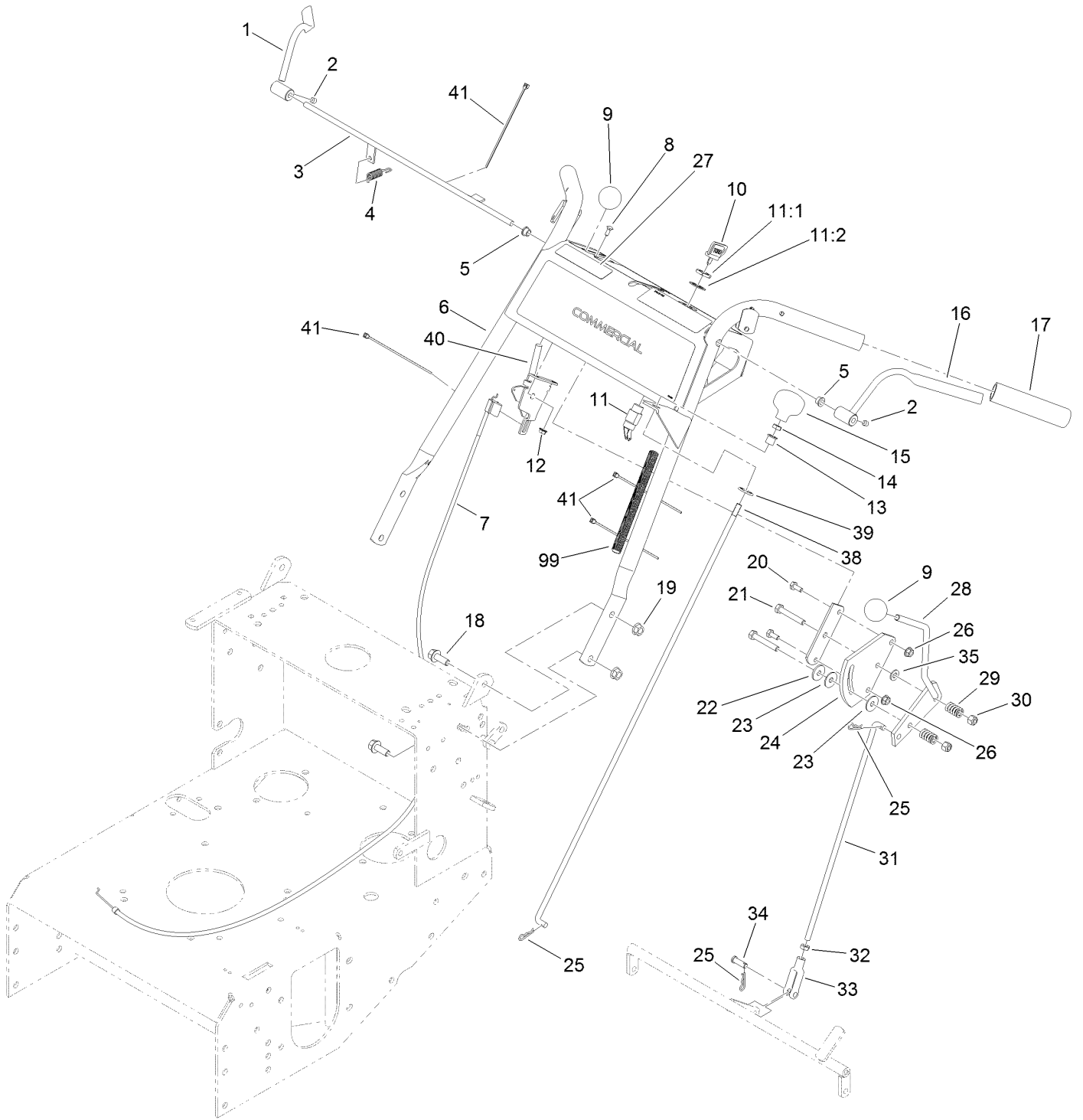

Upper Control Assembly (continued)

<i>Ref.</i>	<i>Part Number</i>	<i>Qty.</i>	<i>Description</i>	<i>Ref.</i>	<i>Part Number</i>	<i>Qty.</i>	<i>Description</i>
1	106-5486	1	RH Operator Presence Control Lever ASM	19	32128-21	4	Nut-HF
2	1-803322	2	Screw-Set	20	321-3	2	Screw-HH
3	106-2717-03	1	Rod-Control, Operator Presence	21	322-10	2	Screw-HH
4	1-303363	1	Spring-Extension	22	1-603716	1	Washer-Friction
5	1-303365	2	Bushing-Nylon	23	1-323244	2	Washer-Friction
6	119-6538	1	Handle ASM	24	1-603730	1	Plate-Lever, Shifter
7	119-1823	1	Cable-Control, Throttle	25	1-806003	3	Pin-Cotter, Hair
8	1-807513	2	Bolt-CARR	26	32128-33	2	Nut-HF
9	1-603175	2	Knob-Ball	27	117-2718	1	Decal-Arrester, Spark
10	63-8360	1	Key-Ignition	28	106-2748	1	Lever-Shift
11	29-5560	1	Switch-On / Off	29	1-323245	2	Spring-Compression
11:1	218-461	1	Nut-HH	30	3296-29	2	Nut-Lock, NI
11:2	3254-5	1	Washer-Tooth, Internal	31	1-323522	1	Rod-Control, Speed
12	32128-17	2	Nut-Lock, Flange	32	3220-2	1	Nut-Jam
13	1-323143	1	Bearing-Nylon	33	1-303105	1	Yoke-Adjustable
14	3218-2	1	Nut-Jam	34	1-808280	1	Pin-Clevis
15	1-323134	1	Knob-Push / Pull	35	3256-23	1	Washer-Flat
16	106-5485	1	LH Operator Presence Control Lever ASM	38	1-323181	1	Linkage-Blade
17	104-9838	2	Grip-Foam	39	1-323142	1	Nut-Push
18	3234-11	4	Screw-HHF	40	110-5547	1	Lever-Control
				41	1-303287	4	Tie-Cable
				99	116-2611	1	Harness-Wiring

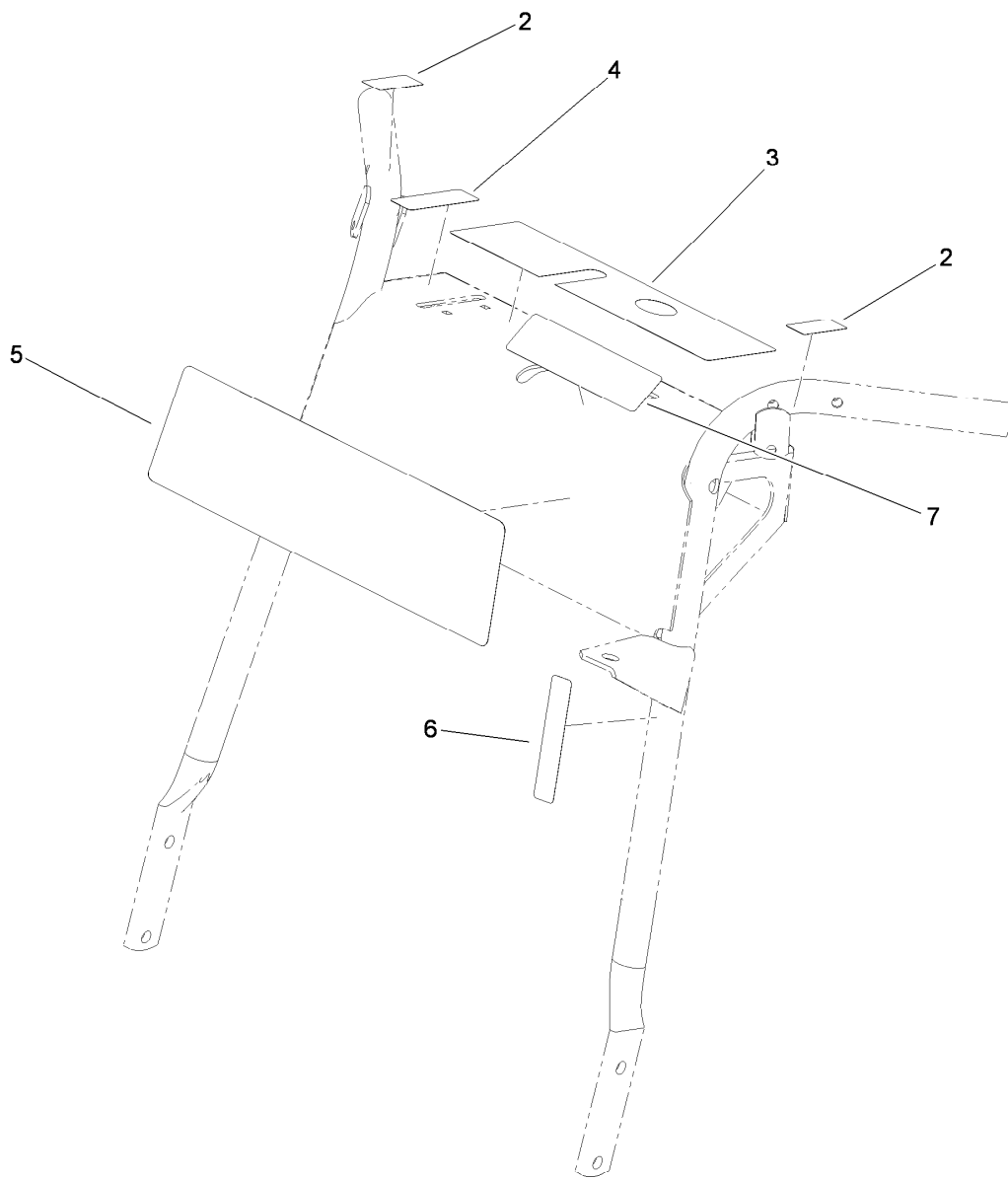

Handle Assembly No. 119-6538

<i>Ref.</i>	<i>Part Number</i>	<i>Qty.</i>	<i>Description</i>
2	130-8370	2	Decal-Lock,Neutral
3	115-1038	1	Decal-Panel, Control
4	106-2733	1	Decal-Throttle
5	110-6917	1	Decal
6	95-5537	1	Decal-Engage, Deck
7	95-5852	1	Decal - Slope, Int'l

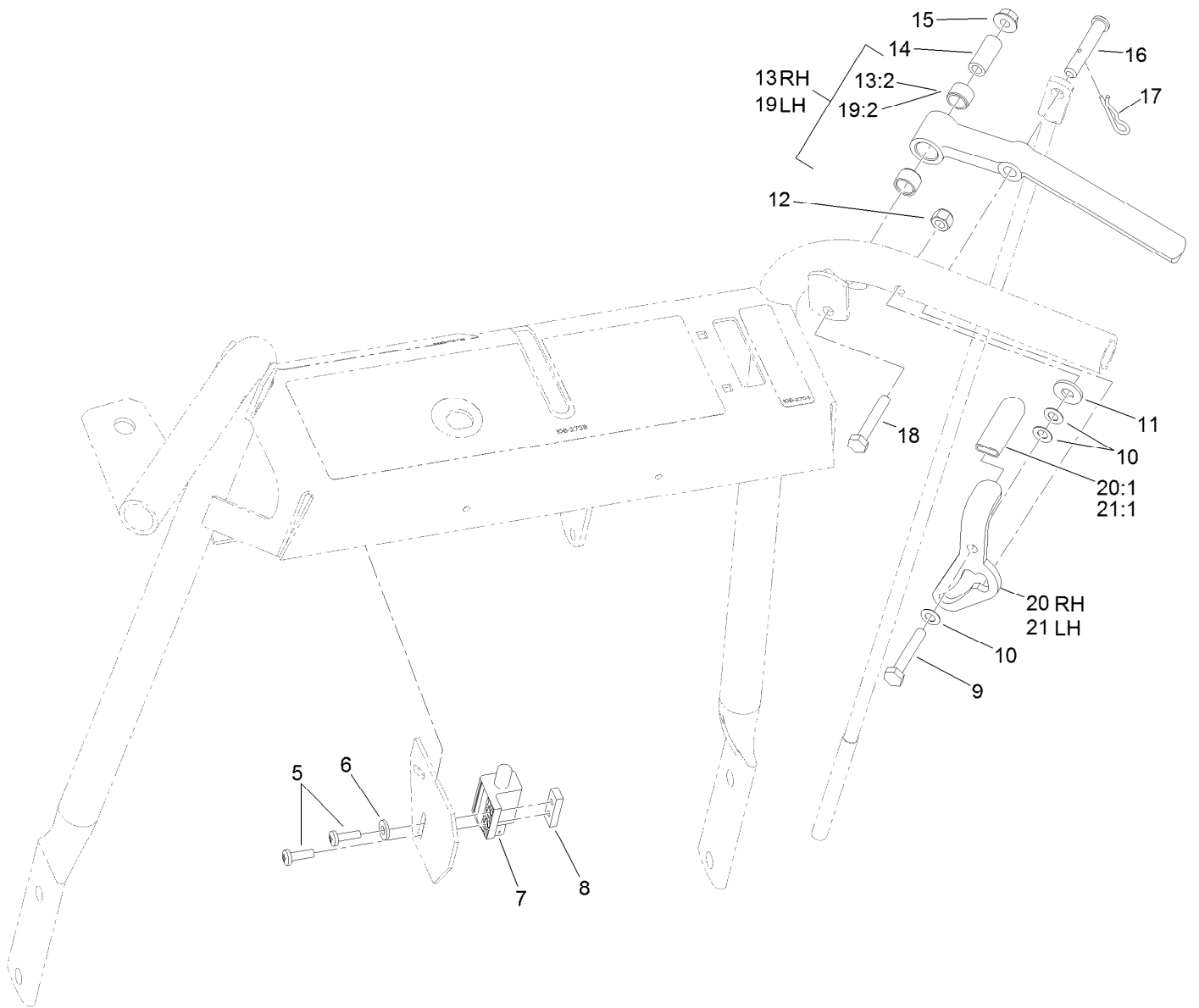

Drive Lever Assembly

Ref.	Part Number	Qty.	Description	Ref.	Part Number	Qty.	Description
5	3290-500	2	Screw-PPH	15	32128-33	2	Nut-HF
6	3256-14	1	Washer-Flat	16	1-613055	2	Pin-Clevis
7	1-513051	1	Switch-Open, Normally	17	1-806003	2	Pin-Cotter, Hair
8	1-633181	1	Plate-Tapped	18	321-9	2	Screw-HH
9	321-10	2	Screw-HH	19	103-0218	1	LH Drive Lever ASM
10	1-303435	6	Washer-Spring	19:2	1-413152	2	Bushing-Sleeve
11	3256-2	2	Washer-Flat	20	1-612168	1	RH Latch And Grip ASM
12	3296-42	2	Nut-Lock, NI	20:1	1-303019	1	Grip-Latch
13	103-0219	1	RH Drive Lever ASM	21	1-612167	1	LH Latch Grip ASM
13:2	1-413152	2	Bushing-Sleeve	21:1	1-303019	1	Grip-Latch
14	1-603749	2	Bushing-Lever, Drive				

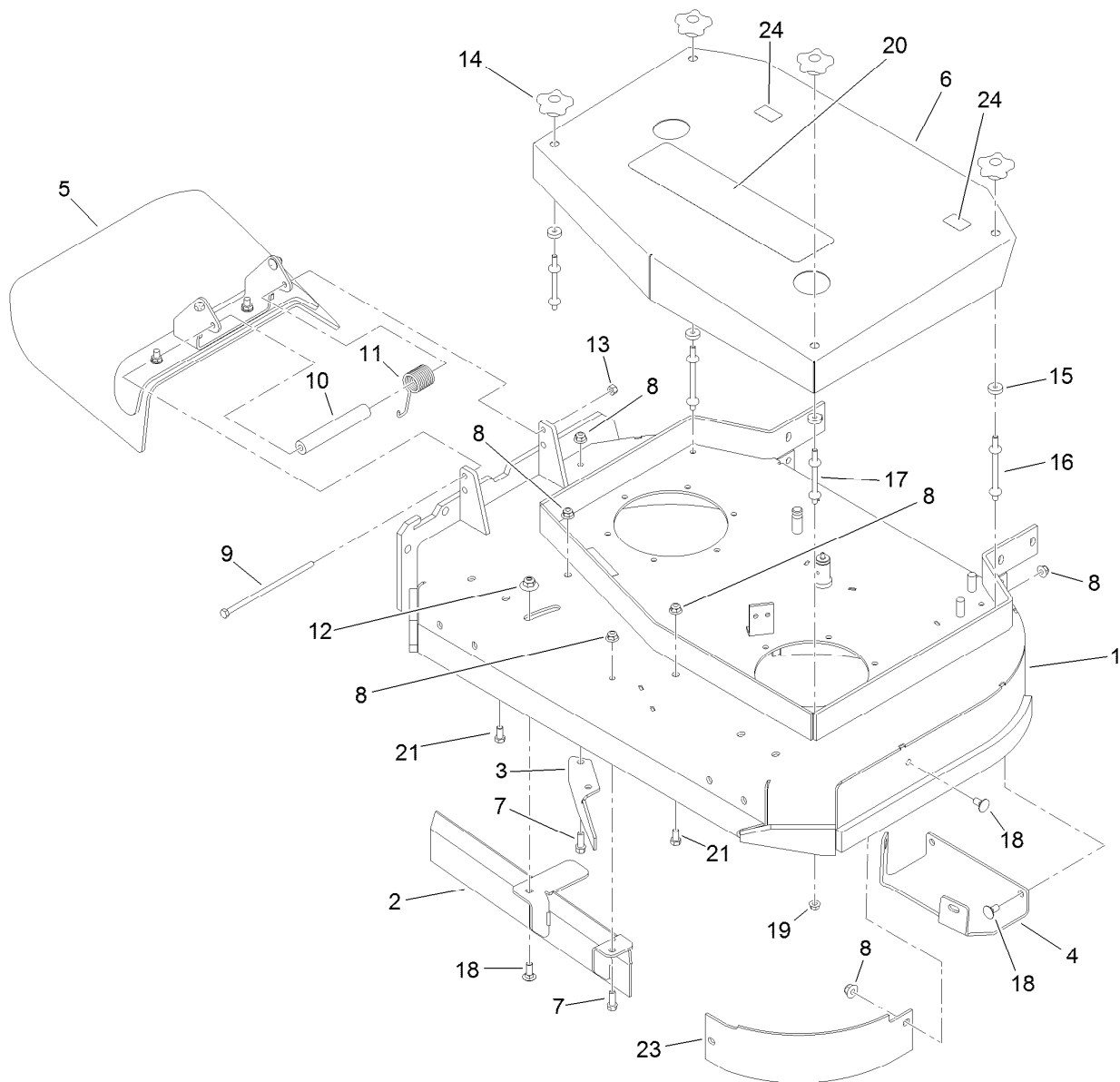

Deck Assembly

<i>Ref.</i>	<i>Part Number</i>	<i>Qty.</i>	<i>Description</i>	<i>Ref.</i>	<i>Part Number</i>	<i>Qty.</i>	<i>Description</i>
1	110-4907	1	Deck ASM	13	3296-47	1	Nut-Lock, NI
2	121-1777-03	1	Baffle	14	106-4161	4	Knob-Handle
3	110-0754-01	1	Baffle-Discharge	15	1-323417	4	Washer
4	110-2037-01	1	Plate-Skid	16	1-303536	2	Stud-Shield, Belt (Long)
5	119-6530	1	Deflector ASM	17	1-303537	2	Stud-Shield, Belt (Short)
6	110-2036-01	1	Cover-Deck	18	3231-2	6	Bolt-CARR
7	92-1624	3	Screw-HWH	19	32128-20	4	Nut-HF
8	104-8301	10	Nut-Flange, NI	20	112-9710	1	Decal
9	322-50	1	Screw-HH	21	323-4	2	Screw-HH
10	105-4622	1	Spacer	23	110-6903-03	1	Baffle-Front, LH
11	108-4052	1	Spring-Torsion	24	106-5517	2	Decal-Warning, Hot Surface
12	109-6658	1	Nut-Flange, NI				

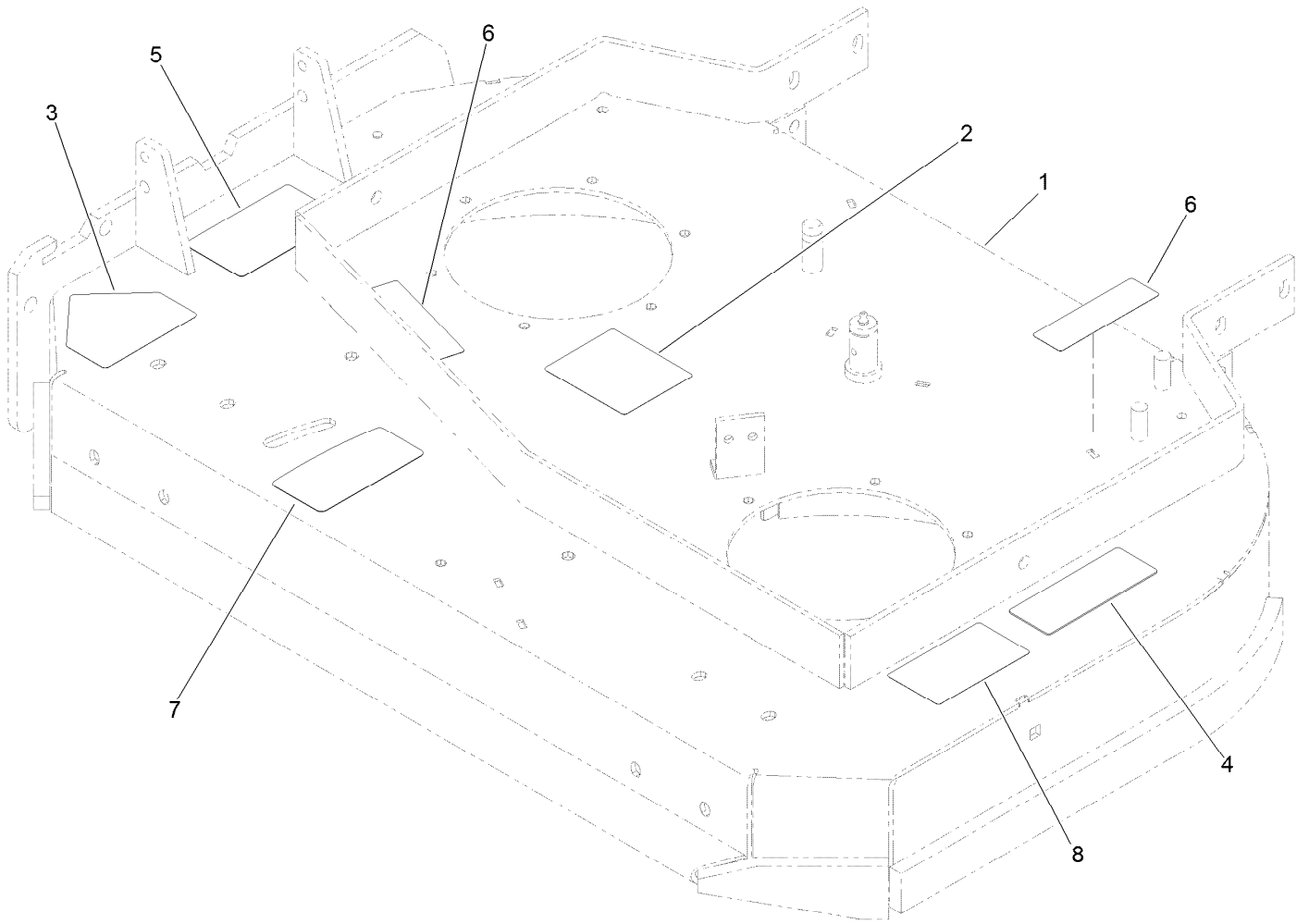

Deck Decal Assembly No. 110-4907

Ref.	Part Number	Qty.	Description
1		1	36 Inch Deck ASM ●
2	98-3296	1	Decal-Routing, Belt
3	112-8760	1	Decal-Danger
4	98-5130	1	Decal-Torque, Bolt
5	121-6049	1	Decal-Danger
6	112-9028	2	Decal-Cover Missing
7	131-1180	1	Decal-Adjustment, Baffle
8	93-7010	1	Decal-Danger

● Not serviced separately

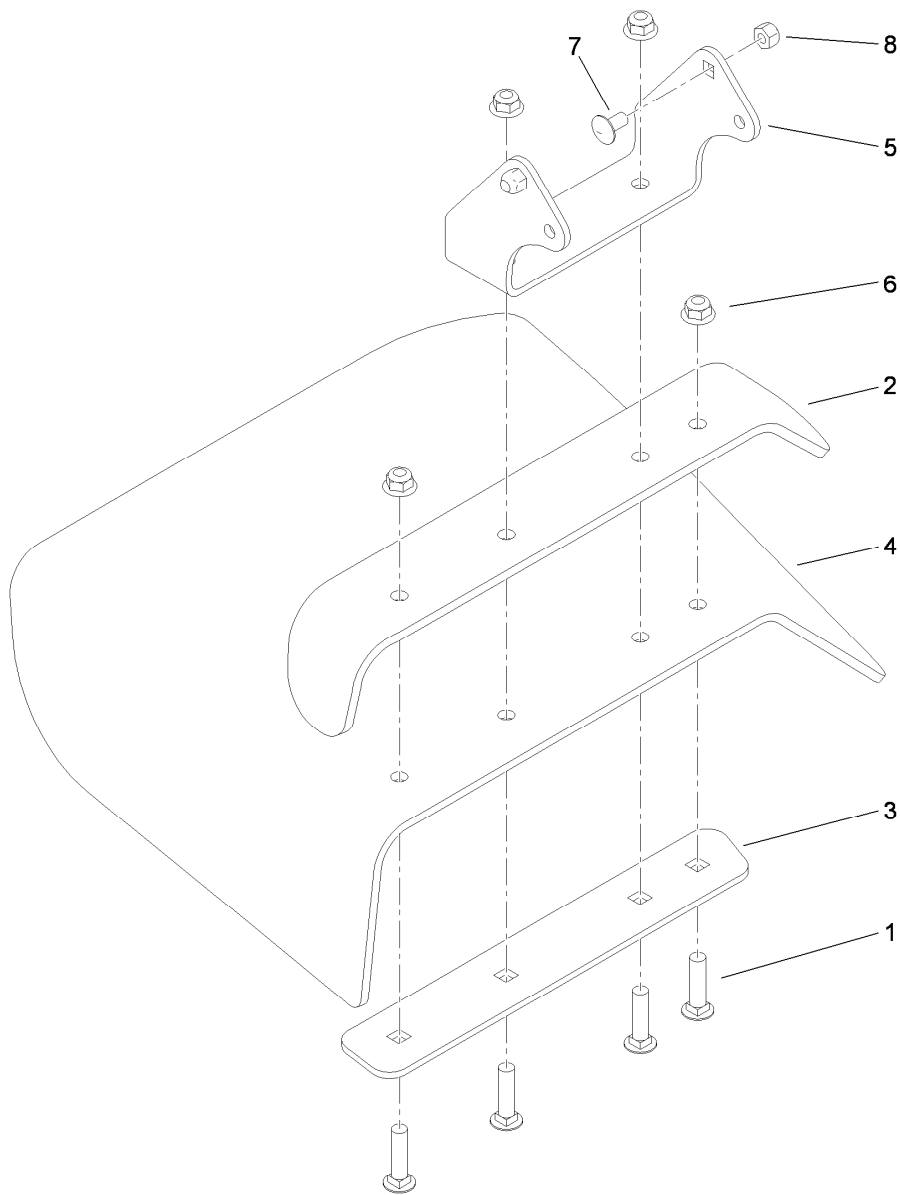

Deflector Assembly No. 119-6530

<i>Ref.</i>	<i>Part Number</i>	<i>Qty.</i>	<i>Description</i>
1	3231-4	4	Screw-CARR
2	110-0792-01	1	Deflector
3	110-0793-03	1	Strap-Discharge
4	110-0791	1	Deflector-Rubber
5	119-6532-01	1	Bracket-Mounting, Deflector
6	104-8301	4	Nut-Flange, NI
7	3230-18	2	Screw-CARR
8	3296-29	2	Nut-Lock, NI

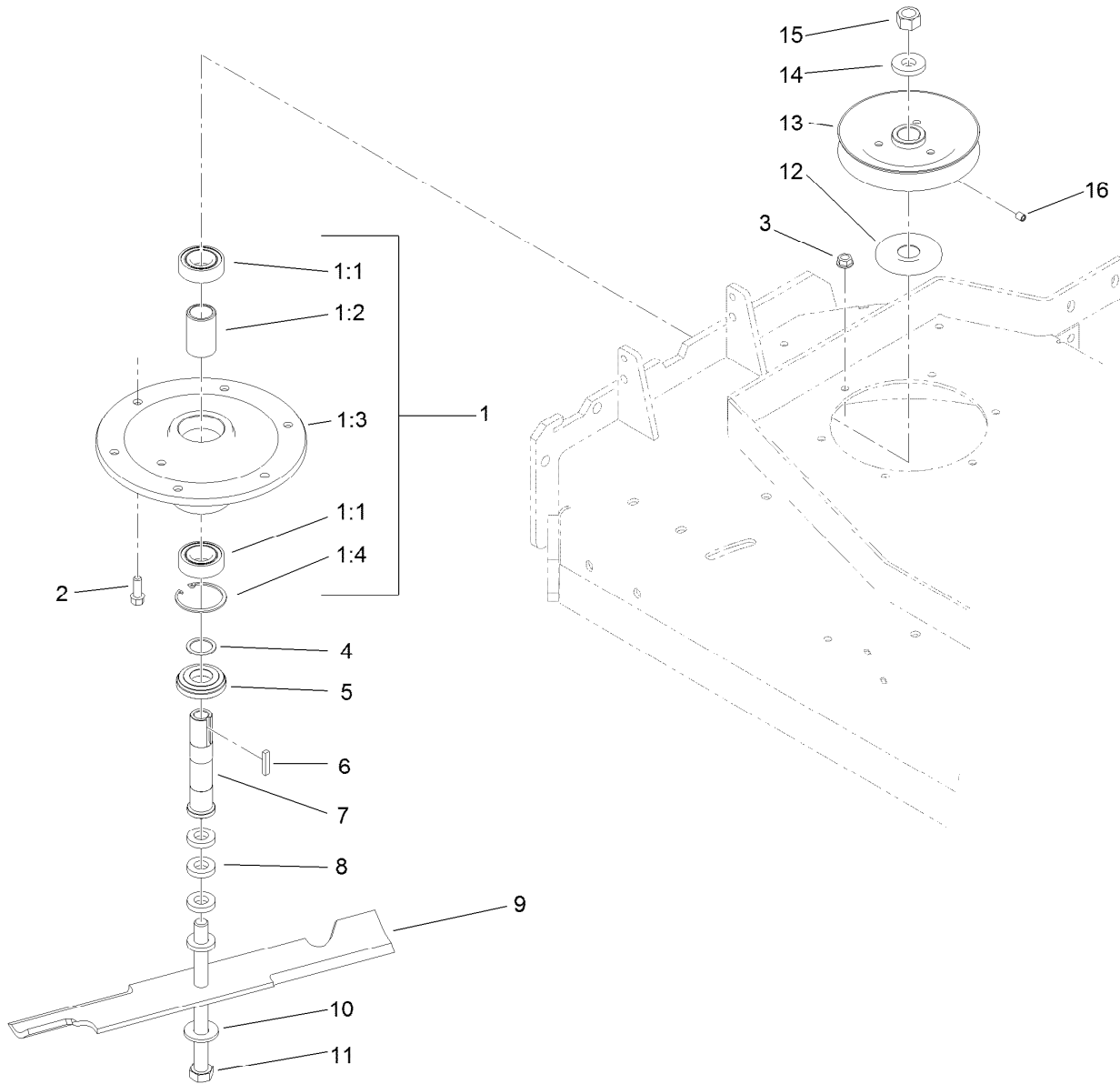

Sheave, Spindle and Blade Assembly

Ref.	Part Number	Qty.	Description
1	108-6697	2	Spindle Housing ASM
1:1	119-7857	2	Bearing-Ball, 1 Inch
1:2	110-2116	1	Spacer-Bearing
1:3	108-6694	1	Housing-Spindle
1:4	32120-8	1	Ring-Snap
2	92-1624	12	Screw-HWH
3	104-8301	12	Nut-Flange, NI
4	110-4888	2	Washer-Spacer
5	103-2535	2	Spacer-Guard, Bottom
6	1-807267	2	Key

Ref.	Part Number	Qty.	Description
7	1-323529	2	Tube-Spindle, Short
8	1-323539	8	Spacer
9	105-7781-03	2	Blade-18In, Hi Flow
10	1-513208	2	Washer-Spring
11	1-800861	2	Screw-Cap, HH
12	103-1330	2	Guard-Bearing, Top
13	1-403183	2	Sheave
14	1-323339	2	Washer-Retainer, Sheave
15	3219-6	2	Nut-Hex
16	3246-18	2	Setscrew

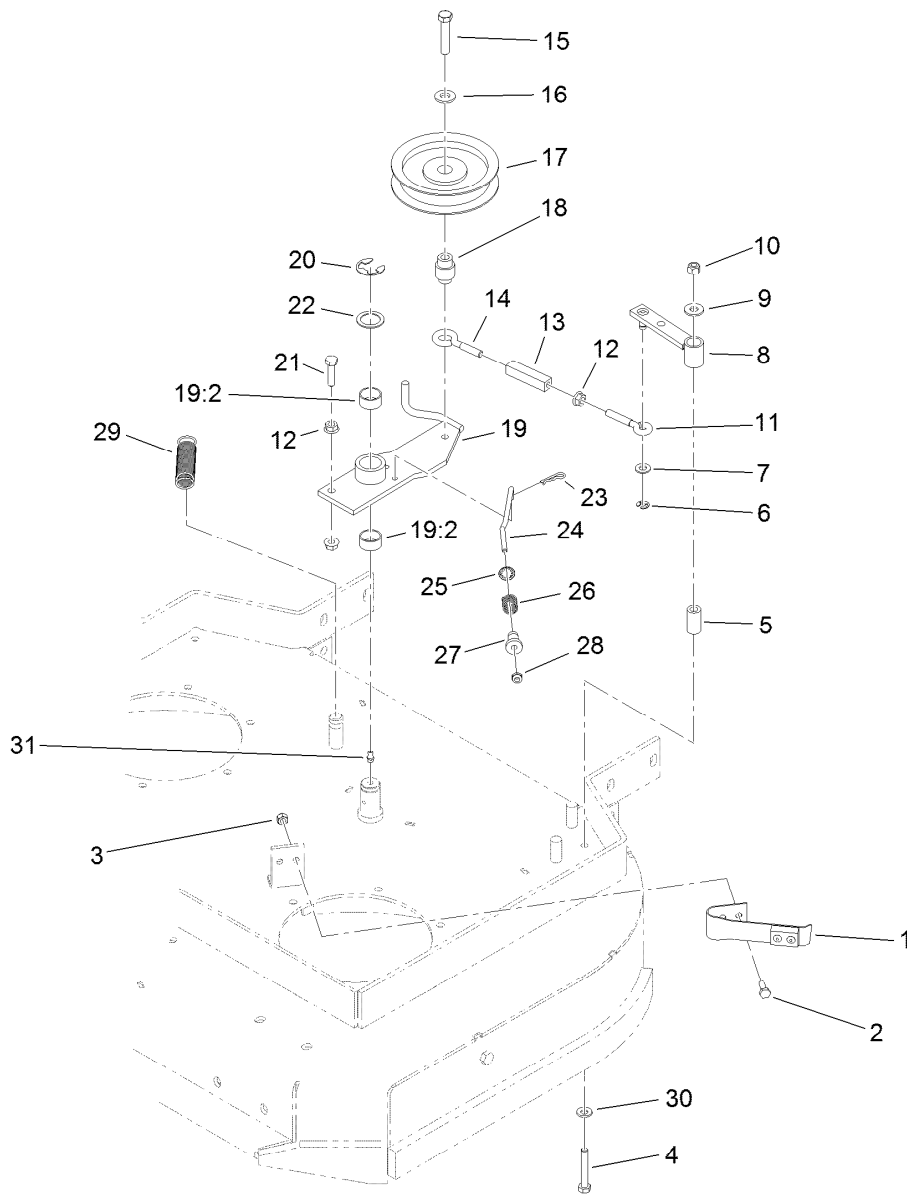

Idler Assembly

Ref.	Part Number	Qty.	Description	Ref.	Part Number	Qty.	Description
1	1-324372	1	Pad And Spring ASM	18	1-303434	1	Bushing-Engagement
2	321-4	2	Screw-HH	19	103-3600	1	Idler Arm ASM
3	3296-42	2	Nut-Lock, NI	19:2	1-323729	2	Sleeve-Bearing
4	322-10	1	Screw-HH	20	32151-103	1	Ring-Retaining, EXT
5	1-403179	1	Tube-Pivot	21	116-3515	1	Screw-HH, Special
6	32120-35	1	Ring-Retaining, EXT	22	1-303352	1	Washer-Spindle
7	3256-23	1	Washer-Flat	23	1-806003	1	Pin-Cotter, Hair
8	1-322235	1	Arm-Assist	24	1-323715	1	Rod-Brake
9	3256-3	1	Washer-Flat	25	1-323748	1	Ring-Push On
10	3296-29	1	Nut-Lock, NI	26	1-323747	1	Spring-Compression
11	1-303238	1	Eyebolt-Thread, RH	27	1-323746	1	Spacer-Flanged
12	32128-20	3	Nut-HF	28	3296-56	1	Nut-Lock, NI
13	1-303236	1	Body-Turnbuckle	29	1-323071	1	Spring-Extension
14	1-303348	1	Eyebolt-Thread, LH	30	1-303334	1	Washer-Spring
15	702809	1	Screw-HH	31	302-40	1	Fitting-Grease, 90 DEG
16	98-5975	1	Washer-Belleville				
17	116-3626	1	Pulley-Idler				

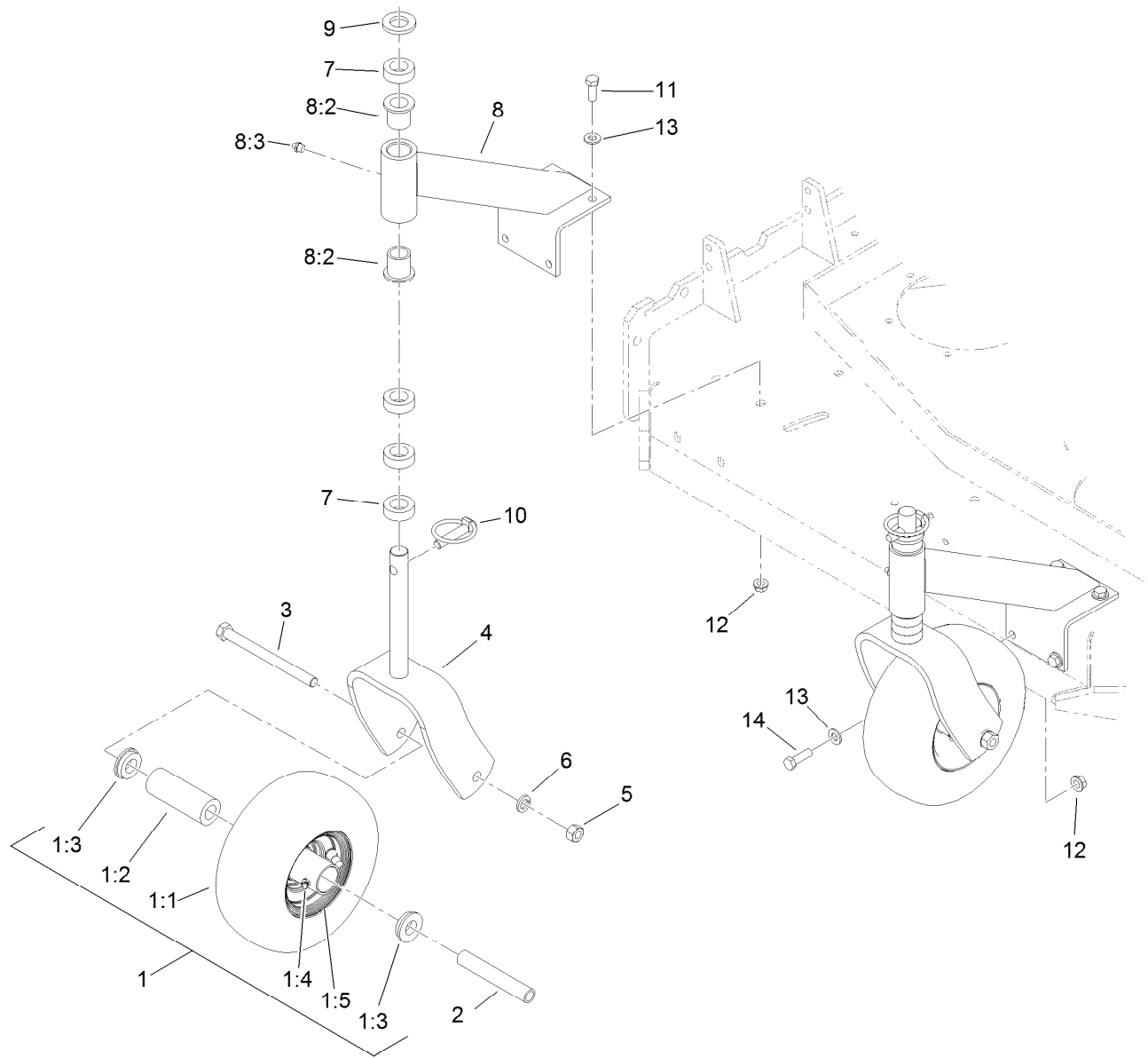

Caster Assembly

Ref.	Part Number	Qty.	Description
1	130-4557	2	Wheel And Tire ASM
1:1		1	Tire ●
1:2	1-513809	1	Bearing
1:3	1-513810	2	Bushing
1:4	302-61	1	Fitting-Grease
1:5		1	Wheel ●
2	1-513547	2	Spacer
3	325-20	2	Screw-HH
4	116-7942-01	2	Fork-Caster
5	3217-9	2	Nut-HH
6	3253-7	2	Washer-Lock

Ref.	Part Number	Qty.	Description
7	1-303314	8	Spacer-Caster
8	110-2130	2	Support ASM
8:2	1-303514	2	Bearing-Flanged
8:3	302-52	1	Fitting-Grease
9	1-513338	2	Washer-Flat
10	1-809020	2	Pin
11	323-6	7	Screw-HH
12	104-8301	8	Nut-Flange, NI
13	3256-24	8	Washer-Flat
14	323-7	1	Screw-HH

● Not serviced separately

Attachments and Accessories

For 39934 Commercial Walk-Behind Mower Fixed Deck, Pistol Grip, Hydro Drive with 36in TURBO FORCE Cutting Unit

Product Name	Model/Part
Soft Bag (3 Bushel).....	30104
36in Bagger Enhancement Kit	110-2026
Blade-Recycler, 18in.....	105-7779-03
Blade-Med Flow, 18in	105-7794-03
Blade-Low Flow, 18in.....	105-7795-03
Blade-Atomic, 18in	105-7796-03
Sulky.....	30109
36in Recycler Kit.....	110-2080
Weight Kit	110-2085
Blade-Recycler, 18in (6 Pack).....	110-0408
Blade-Lo Flow, 18in (6 Pack)	110-0406
Blade-Med Flow, 18in (6 Pack)	110-0409
Blade-Hi Flow, 18in (6 Pack).....	108-1117
Blade-Atomic, 18in (6 Pack)	108-1118
Operator-Controlled Discharge Chute Kit	115-4190
Spark Plug	92-2153
Oil Filter	119-5852
Element-Filter, Air	120-7447
Oil-Synthetic, All Season	117-0066
Toro 4-cycle Sae 30 Oil (32oz Bottle).....	38903

Notes:



Count on it.