



MODEL NO. 04052 - 50001 &amp; Up

OPERATOR'S  
MANUAL

## GREENSMASTER® 1000

*Helping you put quality into play.™*

The GREENSMASTER® 1000 conforms to the American National Standards Institute's safety standards for walk behind mowers; thus Toro proudly displays the ANSI safety seal.



To achieve maximum safety, optimum performance, and to gain knowledge of the machine, it is essential that you or any other operator of the machine read and understand the contents of this manual before the engine is started. Pay particular



attention to the instructions highlighted by the triangular safety alert symbol. Failure to comply with the safety instructions may

result in personal injury.



# FOREWORD

The GREENSMaster® 1000 was developed to provide an efficient trouble free method of mowing high quality turf on the finest greens. The latest concepts of engineering, design and safety have been incorporated into this machine, along with the highest quality parts and workmanship. Excellent service will be derived if proper operation and maintenance practices are followed.

You know, since you have purchased the industry leader in mowing excellence, that future performance and dependability are of prime importance. TORO also is concerned about future use of the machine and of safety to the user. Therefore, this manual must be read by you and those involved with the GREENSMaster 1000® to make sure that safety, proper set-up, operation and maintenance procedures are followed at all times. The major sections of the manual are:

- 1. Safety Instructions
- 2. Set-Up Instructions

- 3. Before Operating
- 4. Operating Instructions

- 5. Maintenance

Safety, mechanical and some general information in this manual are emphasized. **DANGER, WARNING** and **CAUTION** identify safety messages. Whenever the triangle safety symbol appears, it is followed by a safety message that must be read and understood. For more details concerning safety, read the safety instructions on pages 3 and 4. **IMPORTANT** identifies special mechanical information and **NOTE** identifies general information worthy of special attention.

If help concerning set up, operation, maintenance or safety is ever needed, contact your local Authorized TORO Distributor. In addition to genuine TORO replacement parts, the distributor also has optional equipment for the complete line of TORO turf care equipment. Keep your Toro all TORO. Buy genuine TORO parts and accessories.

## TABLE OF CONTENTS

<b>SAFETY INSTRUCTIONS</b> .....	3-4	Method Of Mowing .....	13
<b>SAFETY AND INSTRUCTION DECALS</b> .....	5	Control Operation .....	14
<b>SPECIFICATIONS</b> .....	6	After Mowing .....	14
<b>LOOSE PARTS CHART</b> .....	6	<b>LUBRICATION</b> .....	14
<b>SET-UP INSTRUCTIONS</b> .....	7	Grease Fittings .....	14
<b>PREPARATION BEFORE OPERATING</b> .....	8	<b>MAINTENANCE</b> .....	15
Add Engine Oil .....	8	Engine Oil .....	15
Fill Fuel Tank .....	8	Servicing Air Cleaner .....	15
Leveling Rear Drum To Reel .....	9	Replacing Spark Plug .....	16
Adjust Bedknife To Reel .....	9	Cleaning Fuel Filter .....	16
Adjust Height Of Cut .....	10	Adjusting Belts .....	16
Adjust Grass Shield Height .....	10	Differential Belt Replacement .....	18
Adjusting Cut-off Bar .....	11	Adjusting Traction Control .....	19
Install Grass Basket .....	11	Adjusting Service / Park Brake .....	19
Check Operation of Interlock Switch .....	11	Adjusting Throttle Control .....	19
<b>CONTROLS</b> .....	12	Adjusting Carburetor .....	20
<b>STARTING AND STOPPING</b> .....	13	Adjusting Interlock Switch .....	20
<b>OPERATING INSTRUCTIONS</b> .....	13	Servicing Bedbar .....	20
Transport Operation .....	13	Reel Backlapping .....	21
Preparing To Mow .....	13	<b>IDENTIFICATION AND ORDERING</b> .....	22
Mowing Operation .....	13	<b>MAINTENANCE CHARTS</b> .....	22-23
Prior To Mowing .....	13	<b>THE TORO PROMISE</b> .....	Back cover



## SAFETY INSTRUCTIONS

The GREENSMaster® 1000 was tested and certified by TORO for compliance with the B71.4—1984 specifications of the American National Standards Institute. Although hazard control and accident prevention partially are dependent upon the design and configuration of the machine, these factors are also dependent upon the awareness, concern, and proper training of the personnel involved in the operation, transport, maintenance, and storage of the machine. Improper use or maintenance of the machine can result in injury or death. To reduce the potential for injury or death, comply with the following safety instructions.

**WARNING:** Engine exhaust contains carbon monoxide which is an odorless, deadly poison. Carbon monoxide is also known to the State of California to cause birth defects. Do not run engine indoors or in an enclosed area.

### BEFORE OPERATING

1. Operate the machine only after reading and understanding the contents of this manual. A replacement manual is available by sending complete model and serial number to:

The Toro Company  
8111 Lyndale Avenue South  
Bloomington, Minnesota 55420—1196.

2. Never allow children to operate the machine or adults to operate it without proper instructions.

3. Become familiar with the controls and know how to stop the engine quickly.

4. Keep all shields, safety devices and decals in place. If a shield, safety device or decal is malfunctioning, illegible, or damaged, repair or replace it before operating the machine.

5. Always wear substantial shoes. Do not operate machine while wearing sandals, tennis shoes or sneakers. Do not wear loose fitting clothing which could get caught in moving parts and cause personal injury.

6. Wearing safety glasses, safety shoes, long pants and a helmet is advisable and required by some local safety and insurance regulations.

7. Assure work area is clear of objects which might be picked up and thrown by the reel.

8. Keep everyone, especially children and pets away from the areas of operation.

9. Since gasoline is highly flammable, handle it carefully.

A. Use an approved gasoline container.

B. Do not remove cap from fuel tank when engine is hot or running.

C. Do not smoke while handling gasoline.

D. Fill fuel tank outdoors and no higher than to the bottom of filter screen. Do not overfill.

E. Wipe up any spilled gasoline.

F. Fuel may leak from filler neck when mower is tilted for servicing if tank is over filled.

**10. Check the safety interlock switch daily for proper operation; refer to page 11. If a switch should malfunction, replace the switch before operating machine. (After every two years, replace the interlock switch in the safety system, whether it is working properly or not.)**

### WHILE OPERATING

11. Do not run the engine in a confined area without adequate ventilation. Exhaust fumes are hazardous and could be deadly.

12. Always stand behind the handles when starting and operating the machine.

13. To start and stop the engine:

A. Open fuel shut-off valve.

B. Verify that the traction drive lever on handle is in NEUTRAL position and reel drive lever on mower is DISENGAGED.

C. Move on/off switch to ON position, set choke to full choke position (cold start) and throttle to half throttle.

D. Pull starter cord to start engine.

E. Move throttle to SLOW and on/off switch to OFF position to stop engine.

14. To transport mower from one area to another:

A. Install transport wheels.

B. Disengage reel drive lever.

C. Start engine.

D. Press down on handle to raise front of mower and engage traction drive.

15. Before beginning mowing operation:

A. Stop engine.

B. Disengage traction drive.

C. Remove transport wheels.

D. Engage reel drive lever.

16. Before emptying basket of clippings, disengage traction drive, reduce engine speed and move on/off switch to off position.



## SAFETY INSTRUCTIONS

17. Do not touch engine, muffler or exhaust pipe while engine is running or soon after it has stopped because these areas are hot enough to cause burns.

18. If the cutting unit strikes a solid object or vibrates abnormally, stop immediately, turn engine off, wait for all motion to stop and inspect for damage. A damaged reel or bedknife must be repaired or replaced before operation is commenced.

19. Whenever machine is left unattended, be sure engine is stopped and cutting unit reel is not spinning. Close fuel shut-off valve if machine is not to be used for an extended period of time.

### MAINTENANCE

20. Before servicing or making adjustments to the machine, stop the engine and pull the spark plug wire off spark plug to prevent accidental starting of the engine.

21. To make sure entire machine is in good condition, keep all nuts, bolts, screws and belts properly tightened.

22. If major repairs are ever needed or assistance is required, contact an Authorized TORO Distributor.

23. To reduce potential fire hazard, keep the engine area free of excessive grease, grass, leaves and accumulation of dirt.

24. If the engine must be running to perform a maintenance adjustment, keep hands, feet, clothing, and any parts of the body away from the cutting unit and any moving parts. Keep everyone away.

25. Do not overspeed engine by changing governor settings. Maximum engine speed is 3600 rpm. To assure safety and accuracy, have an Authorized Toro Distributor check maximum engine speed with a tachometer.

26. Engine must be shut off before checking oil or adding oil to the crankcase.

27. To be sure of optimum performance and safety, always purchase genuine TORO replacement parts and accessories. Replacement parts and accessories made by other manufacturers could be dangerous. Such use could void the product warranty of The Toro Company.



# SAFETY AND INSTRUCTION DECALS

The following safety and instruction decals are installed on the machine. If any become damaged or illegible, replace them. Decal part numbers are listed below and in the parts catalog. Order replacements from your Authorized Toro Distributor.



On Control Panel  
Part No. 93-6084



On Front Frame Tube  
Part No. 55-4300

**QUICK REFERENCE CHART**

**CHECK/SERVICE**

1. ENGINE OIL LEVEL
2. FUEL - GAS ONLY
3. AIR CLEANER
4. TIRE PRESSURE (15 PSI.)
5. GREASE POINTS (13)

**FLUID SPECIFICATIONS**  
\*SEE OPERATOR'S MANUAL FOR INITIAL CHANGES.

	TYPE < 50 F	TYPE 50 F-95 F	TYPE > 95 F	CAPACITY	*CHANGE INTERVALS
ENGINE OIL	SAE 10W 30 MS-SC	SAE 30 MS-SC	SAE 40 MS-SC	1.0 Pt. (500cc)	50 HOURS
FUEL	UNLEADED GASOLINE			2.6 QT. (2.5L.)	

On Grass Shield  
Part No. 93-6098

**DANGER**

FUEL IS FLAMMABLE AND COULD CAUSE INJURY IF IGNITED. DO NOT FILL FUEL TANK WITH ENGINE RUNNING, ENGINE HOT OR WHEN IN AN ENCLOSED AREA. DO NOT SMOKE WHILE FILLING TANK.

FILL TANK NO HIGHER THAN TO BOTTOM OF FILLER NECK. DO NOT OVERFILL. WIPE UP SPILLED FUEL BEFORE STARTING ENGINE. FUEL MAY LEAK FROM FILLER NECK WHEN MOWER IS TILTED FOR SERVICING.

**DANGER**

DO NOT OPERATE THIS UNIT UNLESS ALL SHIELDS ARE FIRMLY SECURED. 88-7620

On Fuel Tank  
Part No. 88-7620

**WARNING**

**SHIELD MISSING DO NOT USE**  
88-8950

Inside Belt Covers (3)  
Part No. 88-8950

**DANGER**

**NEVER PLACE HANDS OR FEET IN REEL AREA WHILE ENGINE IS RUNNING.**

On Grass Shield  
Part No. 62-5070



On Control Panel  
Part No. 93-6085

**WARNING**

**HOT**

On Fuel Tank  
Part No. 63-8440

**DANGER**

DO NOT OPERATE THIS UNIT UNLESS ALL SHIELDS ARE FIRMLY SECURED.

Inside Belt Cover  
Part No. 675360

**REEL DRIVE ENGAGEMENT**

**ENGAGE**

**DISENGAGE**

On Belt Cover  
Part No. 65-7660

# SPECIFICATIONS

**Engine:** Kawasaki, air cooled, overhead valve, 4 cycle, 3.7 horsepower, 2.36" x 1.73" bore and stroke, 7.57 cu. in. (124 cc) displacement, 8.4:1 compression ratio, 11 ft. lbs. @ 1400 rpm. Electronic ignition, maximum noise suppression muffler. 2.64 quart fuel tank capacity.

**Traction Drive:** Engine to countershaft drive: two "A" section V-belts. Countershaft to differential drive: 5 mm pitch timing belt. Differential to drum drive: 8 mm pitch timing belt.

**Differential:** Peerless Series 100.

**Transport Clutch:** Belt idler

**Brake:** Band drum

**Optional Transport Tires:** Quick detachable, 3.00/3.25 x 6, 32.5 tread width.

**Traction Drum:** Dual cast aluminum, 7.5" dia.

**Controls:** Engine has recoil starter, ON/OFF switch and choke. Handle has throttle lever, traction engage lever and service/ park brake lever. Mower has reel drive engage lever. Safety devices: neutral interlock system.

**Handle:** Loop style, 1" dia.

**Reel Construction:** 5" diameter, 11 carbon steel blades welded to 5 stamped steel spiders.

**Width of Cut:** 21"

**Height of Cut Range:** 5/64" to 1"

**Clip:** .16"

**Reel Clutch:** Jaw Type.

**Bedknife and bedbar:** Single edged high carbon steel bedknife, hardened to Rc 48-54. Fastened to machined, cast iron bedbar. Tournament bedknife (Part No. 93-4263), standard.

**Grass Basket:** Molded polyethylene.

**Dimensions:**

Width: 36"

Height: 47"

Length: 59"

Dry Weight: 208 lbs. with basket and Wiehle roller, without wheels or grooming reel.

**Optional Equipment:**

Wheel and Kickstand Kit – Model No. 04121

Wiehle Roller (Cast Iron) – Model No. 04118

Full Roller – Part No. 52-3170

Swagged Roller – Part No. 52-3590

Auxiliary Roller Kit – Part No. 65-8560

Grooming Reel Kit – Model No. 04125

Groomer Brush Assembly – Part No. 65-8330

1/8" Bedknife – Part No. 93-4264

Micro Cut Bedknife – Part No. 93-4262

Clip Kit (.25 clip) – Part No. 65-9000

# LOOSE PARTS CHART

**Note:** Use this chart as a checklist to ensure all parts necessary for assembly have been shipped. If any of these parts are missing, total set-up cannot be completed.

Description	Qty	Use
Handle Assembly	1	Mount handle to machine.
Cable Ties	2	Secure control cables to handles.
Grass Basket	1	Install on machine.
Gauge Bar Assembly	1	Use to set height-of-cut.
Operator's Manual	1	Read before operating machine.
Parts Catalog	1	
Registration Card	1	Fill out and return to Toro.

# SET-UP INSTRUCTIONS

**Note:** Left and right sides of machine refer to normal operating position.

## INSTALL AND ADJUST HANDLE

### To Install Handle

1. Remove capscrew, washer and lockwasher from mounting pin on each side of mower, as shown in fig. 1.

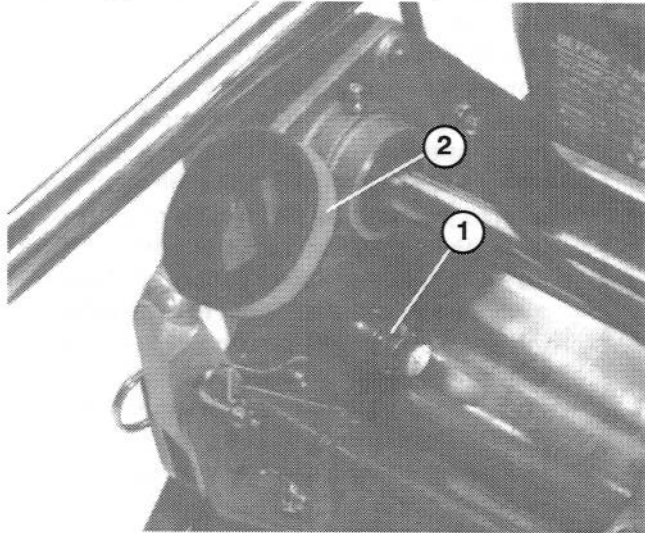

**Figure 1**

1. Mounting pins
2. Handle arms

2. Insert handle ends thru holes in handle arms and align holes with mounting pins (Fig. 1).

**Note:** Hair pin cotters and ring pins may have to be removed from handle arms to allow handle installation.

3. Squeeze handle ends inward and install on mounting pins (Fig. 2).

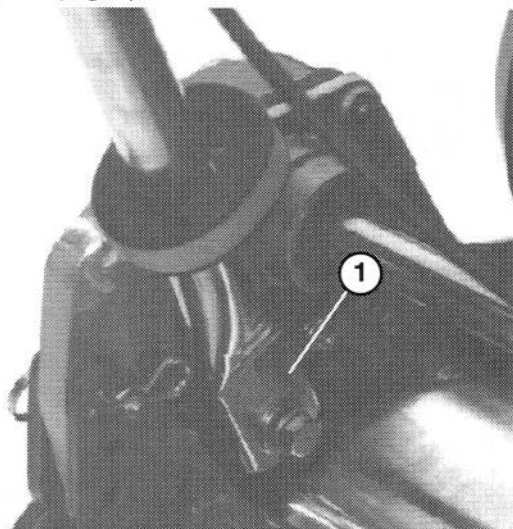

**Figure 2**

1. Handle end

4. Secure handle ends to mounting pins with capscrews, washers and lockwashers previously removed (Fig. 2).

5. Secure cables to handle with cable ties.

### To Adjust Handle

1. Remove hairpin cotters from ring pins on each side of mower (Fig. 2).
2. While supporting handle, remove ring pins from each side and raise or lower handle to desired operating position. (Fig. 2).
3. Reinstall ring pins and hair pin cotters.

## INSTALL TRANSPORT WHEELS (Optional)

1. Push kick stand down with foot and pull up on handle to support mower on kick stand.

2. Apply Never-Seez to the exposed ends of axles and slide wheel onto axle (Fig. 3).

3. Pivot wheel locking clip away from center of wheel allowing wheel to slide farther onto axle (Fig. 3).

4. Rotate wheel back and forth until it slides completely onto axle and locking clip is secured in groove on axle shaft.

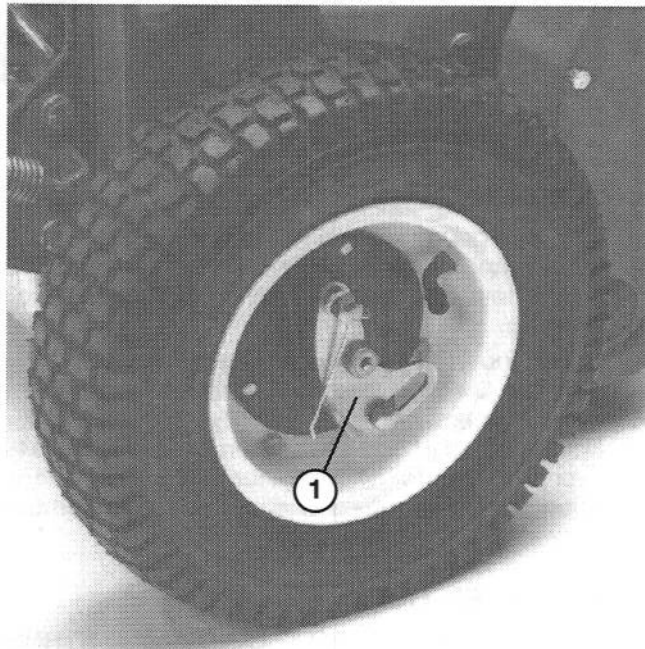

**Figure 3**

1. Locking clip

5. Repeat procedure on opposite side of machine.
6. Tires to be inflated to 12–15 psi.

# PREPARATION BEFORE OPERATING

## ADD ENGINE OIL

Initially, crankcase must be filled with approximately 16 ounces of proper viscosity oil (See chart below). Use any high quality detergent oil having the American Petroleum Institute (API) "service classification"—MS, or SC.

Temperature	Oil Viscosity
50° or below	SAE 10W30 wt.
50° to 95°	SAE 10W30 wt. or 30 wt.
Above 95°	SAE 40

1. Position mower so the engine is level and clean around oil level gauge (Fig. 4).

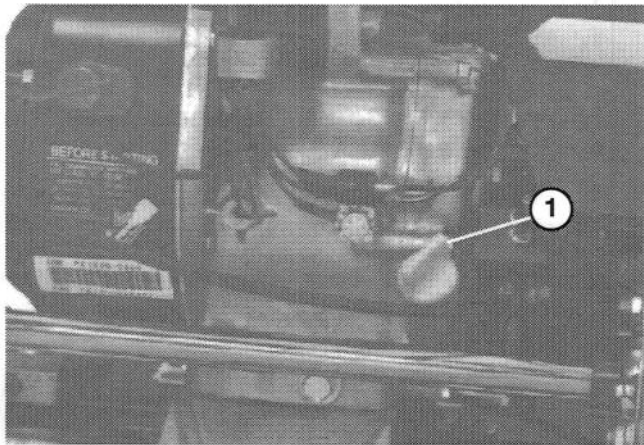

**Figure 4**  
1. Oil level gauge

2. Remove gauge by rotating counterclockwise.
3. Wipe gauge clean and insert it into filler port. Then remove and check level of oil. Do not screw into port. If level is low, add only enough oil to raise level to filler opening.

**Note:** The TORO Company recommends that the oil level be checked each time mower is used or after every 5 operating hours. Initially, change oil after the first 20 hours of operation; thereafter, change oil after every 50 hours of operation. **More frequent oil changes are required in dusty or dirty conditions.**

## FILL FUEL TANK

**NOTE:** THE TORO COMPANY STRONGLY RECOMMENDS THE USE OF FRESH, CLEAN, **UNLEADED** REGULAR GRADE GASOLINE IN TORO GASOLINE POWERED PRODUCTS. UNLEADED GASOLINE BURNS CLEANER, EXTENDS ENGINE LIFE, AND PROMOTES GOOD STARTING BY REDUCING THE BUILD-UP OF COMBUSTION CHAMBER DEPOSITS. LEADED GASOLINE CAN BE USED IF UNLEADED IS NOT AVAILABLE.

**NOTE:** NEVER USE METHANOL, GASOLINE CONTAINING METHANOL, GASOLINE CONTAINING MORE THAN 10% ETHANOL, GASOLINE ADDITIVES, PREMIUM GASOLINE OR

**WHITE GAS BECAUSE ENGINE FUEL SYSTEM DAMAGE COULD RESULT.**



## DANGER

Because gasoline is flammable, caution must be used when storing or handling it. Do not fill fuel tank while engine is running, hot or when machine is in an enclosed area. Vapors may build up and be ignited by a spark or flame source many feet away. **DO NO SMOKE** while filling the fuel tank to prevent the possibility of an explosion. Always fill fuel tank outside and wipe up any spilled gasoline before starting engine. Use a funnel or spout to prevent spilling gasoline, and fill tank no higher than to bottom of filter screen. **DO NOT OVER FILL.** Store gasoline in a clean safety approved container and keep the cap on the container. Keep gasoline in a cool, well-ventilated place; never in an enclosed area such as a hot storage shed. To assure volatility, do not buy more than a 30 day supply of gasoline. Gasoline is a fuel for internal combustion engines; therefore do not use it for any other purpose. Since many children like the smell of gas, keep it out of their reach because the fumes are explosive and dangerous to inhale.

1. Clean around fuel tank cap and remove cap from tank (Fig. 5). Using unleaded gasoline, fill fuel tank no higher than to bottom of filter screen. **DO NOT OVER FILL.**

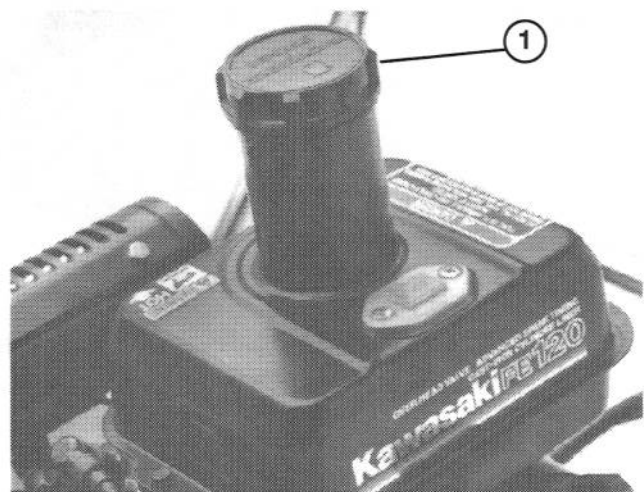

**Figure 5**  
1. Fuel tank cap

2. Install fuel tank cap and wipe up any spilled gasoline.

# PREPARATION BEFORE OPERATING

## LEVELING REAR DRUM TO REEL

1. Position machine on a flat, level surface preferably a precision steel work plate. Place a 1/4" x 1" flat steel strip, approx. 24" long, under reel blades and against front edge of bed knife to prevent the bedbar from resting on the work surface.
2. Raise front roller so only rear drum and reel are on surface.
3. Firmly press down on machine above reel so all reel blades contact the steel strip.
4. While pressing down on reel, slide a feeler gauge under one end of drum, then check other end of drum. If there is a gap between the drum and the work surface, greater than .010", on either end, an adjustment to the drum is required, proceed to step 5. If the gap is less than .010" no adjustment is required.
5. Remove rear belt cover from right side of machine.
6. Rotate drive pulley until holes align with (4) roller bearing flange screws (Fig. 6).
7. Loosen (4) roller bearing screws and screw securing idler pulley. Raise or lower right side of roller assembly until the gap is reduced to less than .010". Retighten the roller bearing screws. Adjust belt tension and tighten idler pulley mounting screw (Fig. 6).

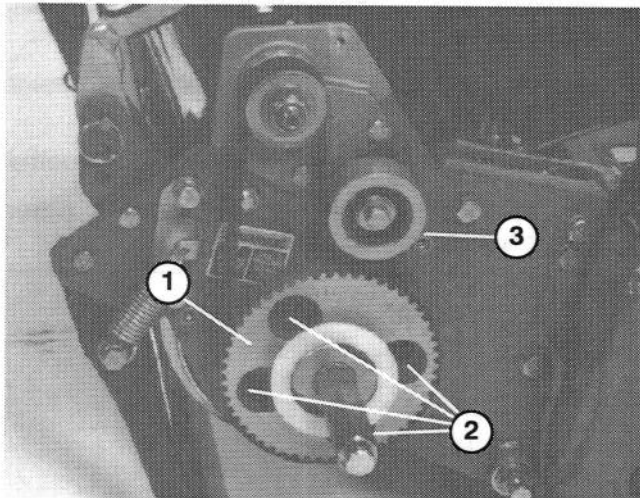

Figure 6

1. Drive pulley      2. Four holes      3. Idler Pulley

## ADJUST BEDKNIFE TO REEL

Bedknife to reel adjustment is accomplished by loosening or tightening bedknife adjusting screws, located on top of mower.

1. Position machine on a flat, level work surface. Make sure reel contact is removed by loosening jam nuts on bedknife adjusting screws and rotating adjusting screws counterclockwise (Fig. 7).

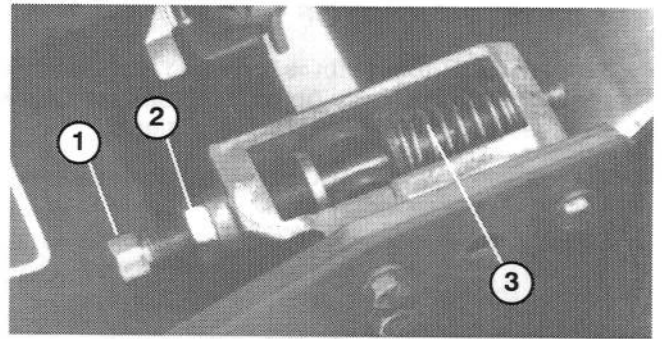

Figure 7

1. Bedknife adjusting screw  
2. Jam nut  
3. Spring

2. Tilt mower back on handle to expose bedknife and reel.
3. On one end of front side of reel, insert a long strip of newspaper between reel and bedknife (Fig. 8). While slowly rotating reel forward, tighten bedknife adjusting screw, (on same end of reel, one flat at a time, until paper is pinched lightly, when inserted from the front, parallel to the bedknife, which results in a slight drag when paper is pulled (Fig. 7).

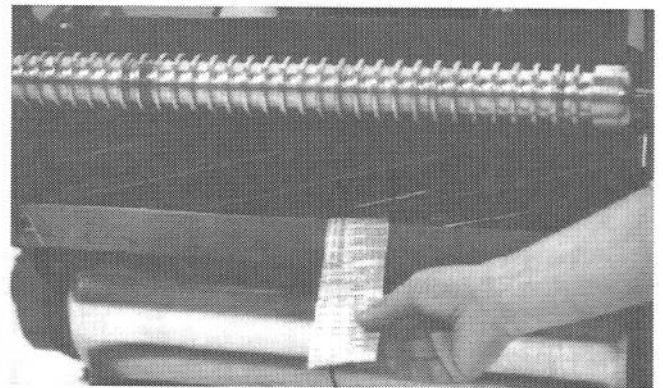

Figure 8

**Note:** Each time adjusting screw is rotated one flat, bedknife moves .003" closer to reel. **DO NOT OVERTIGHTEN ADJUSTING SCREWS.**

4. Check for light contact at other end of reel using paper and adjust as required. Make sure to tighten jam nuts on adjusting screws upon completion of adjustment.
5. After adjustment is accomplished, check to see if reel can pinch paper when inserted from the front and cut paper when inserted at a right angle to the bedknife (Fig. 8). It should be possible to cut paper with minimum contact between the bedknife and the reel blades. Should excessive reel drag be evident (more than 7 inch pounds) it will be either necessary to backlap or re-grind the cutting unit to achieve the sharp edges needed for precision cutting (see Toro reel sharpening manual).

**WARNING:** Use caution if removing bedbar because adjusting screw springs (Fig. 7) are under tension and could release suddenly.

# PREPARATION BEFORE OPERATING

## ADJUST HEIGHT OF CUT

1. Verify that rear roller is level and that bedknife to reel contact is correct. Tip mower back on handle to expose front and rear rollers and bedknife.
2. Loosen locknuts securing height-of-cut arms to height-of-cut brackets (Fig. 9).

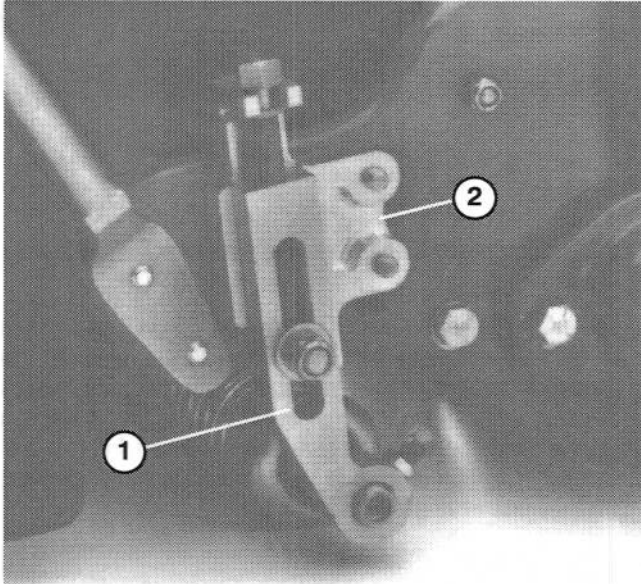

Figure 9

1. Height-of-cut arm
2. Height-of-cut bracket
3. Locknut

3. Loosen nut on gauge bar (Fig. 10) and set adjusting screw to desired height-of-cut. Distance between bottom of screw head and face of bar is height-of-cut.

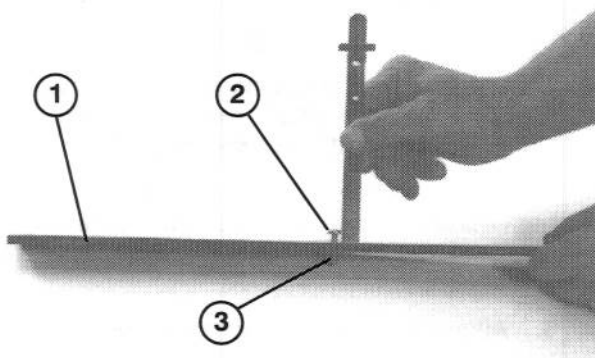

Figure 10

1. Gauge bar
2. Height adjusting screw
3. Nut

4. Hook screw head on cutting edge of bedknife and rest rear end of bar on rear roller (Fig. 11).
5. Rotate adjusting screw until roller contacts front of gauge bar. Adjust both ends of roller until entire roller is parallel to the bedknife.

10

**IMPORTANT:** When set properly, rear and front rollers will contact gauge bar and screw will be snug against bedknife. This assures height-of-cut is identical at both ends of bedknife.

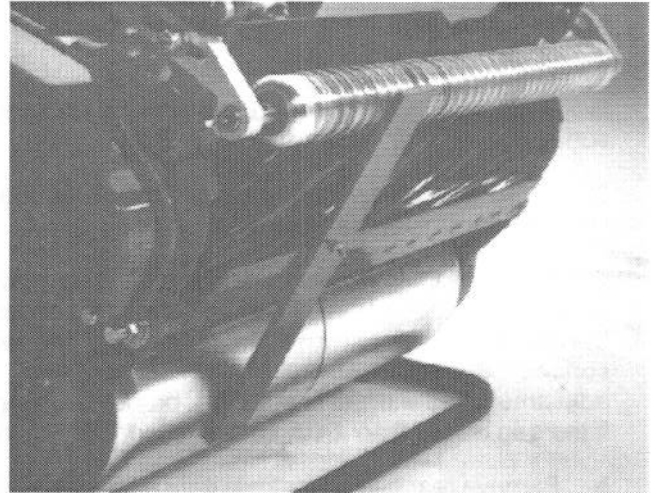

Figure 11

6. Tighten nuts to lock adjustment.

**IMPORTANT:** To avoid scalping on undulating turf, make sure roller supports are positioned rearward (roller closer to reel).

**NOTE:** The front roller can be put in three different positions (Fig. 12) depending on the application and needs of the user.

- The front position is used when a groomer is installed.
- The middle position is used without a groomer.
- The third position can be used in extremely undulating turf conditions.

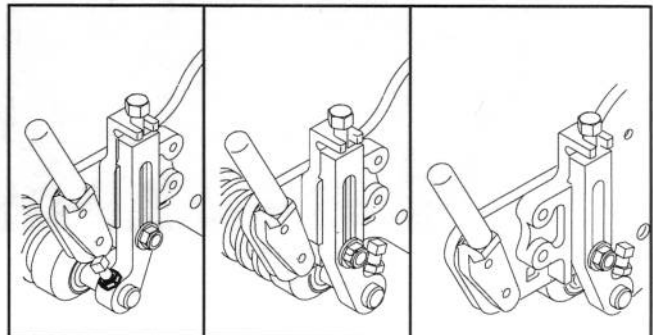

Figure 12

## ADJUSTING GRASS SHIELD HEIGHT

Adjust shield to assure proper grass clipping discharge into basket.

1. Measure distance from top of front support rod to the front lip of the shield at each end of cutting unit (Fig. 13).

# PREPARATION BEFORE OPERATING

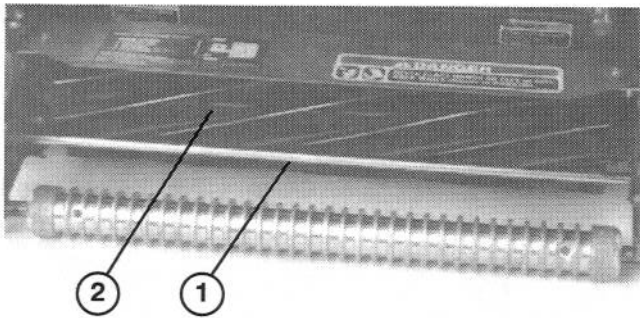

**Figure 13**

1. Support Rod 2. Shield

2. Height of shield from support rod for normal cutting conditions should be 4 inches. Loosen capscrews and nuts securing each end of shield to sideplate, adjust shield to correct height and tighten fasteners.

**Note:** Shield can be lowered for drier conditions (clippings fly over top of basket) or raised to allow for heavy wet grass conditions (clippings build up on rear of basket).

## ADJUSTING CUT-OFF BAR

Adjust cut-off bar to assure clippings are cleanly discharged from the reel area:

1. Loosen screws securing top bar (Fig. 14) to cutting unit. Insert .060 inch feeler gauge between top of reel and bar and tighten screws. Assure bar and reel are equal distance apart across complete reel.

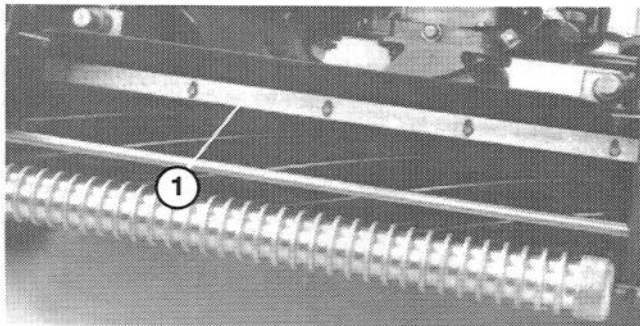

**Figure 14**

1. Cut-off bar

**Note:** Bar is adjustable to compensate for changes in turf conditions. Bar should be adjusted closer to reel when turf is extremely wet. By contrast, adjust bar further away from reel when turf conditions are dry. Bar should be parallel to reel to assure optimum performance and should be adjusted whenever shield height is adjusted or whenever reel is sharpened on a reel grinder.

## INSTALL GRASS BASKET

1. Grasp basket by top rear lip and slide onto the basket mounting rods (Fig. 15).

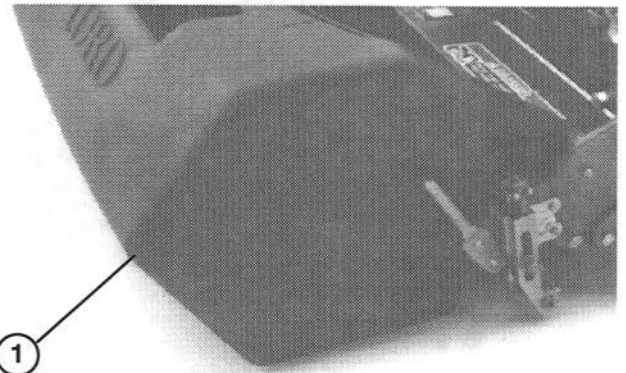

**Figure 15**

1. Grass basket

## CHECK INTERLOCK SWITCH OPERATION

1. Place traction lever into ENGAGE position and engine controls in starting position.

2. Attempt to start engine. Engine should not start. If engine starts, the interlock switch needs service. Correct problem before operating. Refer to Adjusting Interlock Switch.

# CONTROLS

**Traction Engagement Lever** (Fig. 16) - Located on front right side of control panel. Lever has two positions: NEUTRAL and FORWARD. Pushing lever forward engages traction drive.

**Service/Park Brake** (Fig. 16) - Located on left front side of control panel. Use brake to slow or stop machine. The brake can also be used as a parking brake. Pulling the lever back over center will set the parking brake.

**Throttle Control** (Fig. 16) - Located on rear right side of control panel. Lever connects to and operates throttle linkage to carburetor. Engine speed can be varied from 1600 RPM to 3600 RPM.



**Figure 16**

1. Throttle control
2. Traction engagement lever
3. Service / park brake

**Reel Drive Engagement Lever** (Fig. 17) - Located on right front corner of machine. Lever has two positions: ENGAGE and DISENGAGE. Pull up on lever to engage reel or push down on lever to disengage reel.

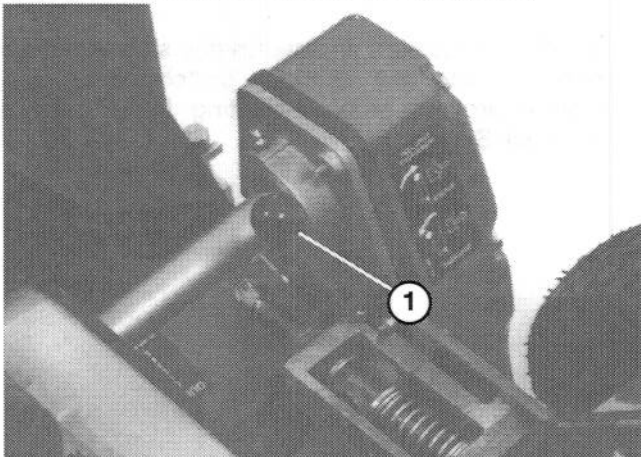

**Figure 17**

1. Reel drive engagement lever

**Choke Lever** (Fig. 18) - Located on left front of engine. Lever has two positions: RUN and CHOKE. Move lever

to CHOKE position when starting a cold engine. After engine starts move lever to RUN position.

**Fuel Shut-off Valve** (Fig. 18) - Located on left front of engine. Valve has two positions: CLOSED and OPEN. Move lever to closed position when storing or transporting machine. Open valve before starting engine.

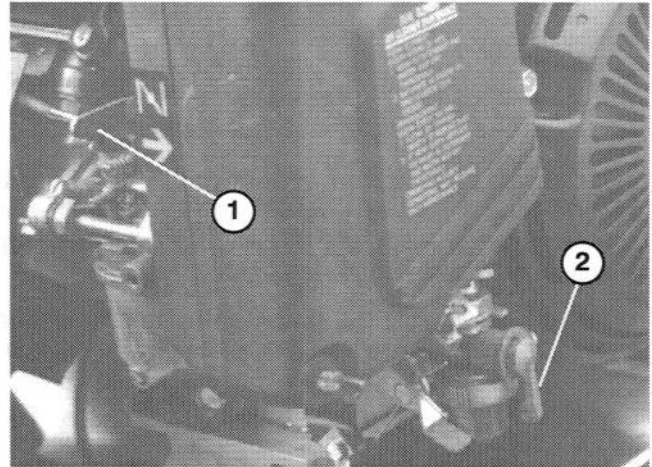

**Figure 18**

1. Choke lever
2. Fuel shut off valve

**Recoil Starter** (Fig. 19) - Pull recoil starter handle to start engine.

**On/Off Switch** (Fig. 19) - Located on rear of engine. Move switch to ON position to start engine and Off to stop engine.

**Kick Stand** (Optional) (Fig. 19) - Mounted to rear of machine, kickstand is used to raise rear of machine for installation or removal of transport wheels.

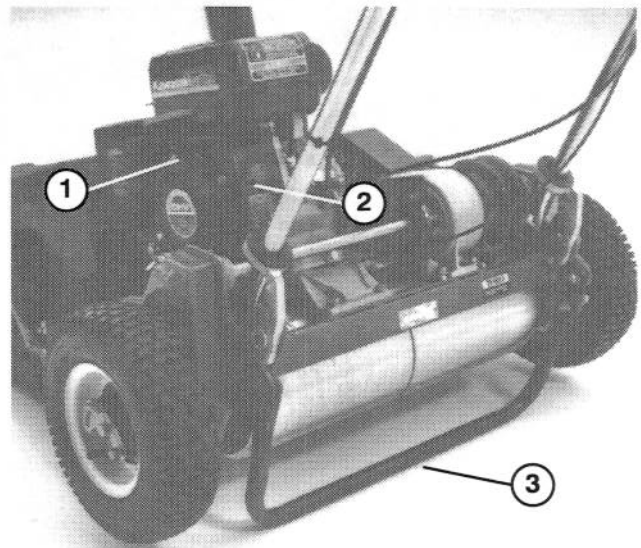

**Figure 19**

1. Recoil starter
2. On/Off Switch
3. Kickstand

# STARTING AND STOPPING

**Note: Make sure spark plug wire is installed on spark plug.**

1. Make sure traction (Fig. 16) and reel drive (Fig. 17) levers are in DISENGAGED position.

**Note:** Engine will not start if traction lever is in the engaged position.

2. Open fuel shut-off valve on engine (Fig. 18).

3. Move ON / OFF switch (Fig. 19) to ON position .

4. Move throttle control (Fig. 16) to FAST position.

5. Move choke lever (Fig. 18) to half-open position when starting a cold engine. Choke may not be required when starting a warm engine.

6. Pull recoil starter handle out until positive engagement results, then pull vigorously to start engine. Close choke as engine warms up.

**Note: Do not pull recoil rope to its limit or let go of starter handle when rope is pulled out because rope may break or recoil assembly may be damaged.**

7. To stop engine during operation, move traction and reel drive controls to DISENGAGED position, throttle control to SLOW and ON/OFF switch to OFF.

8. Pull spark plug wire off spark plug to prevent the possibility of accidental starting before storing machine.

9. Close fuel shut-off valve before storing or transporting mower in a vehicle.

## OPERATING INSTRUCTIONS

### TRANSPORT OPERATION

1. Push kick stand down with foot and pull up on handle to raise rear of mower and install transport wheels.

2. To release kickstand, pull up on handle, push mower forward and then lower rear of mower onto transport wheels.

3. Assure traction and reel drive controls are in DISENGAGE position and start engine.

4. Set throttle control in SLOW, tip front of machine up and slowly increase engine speed while gradually engaging traction drive so mower moves forward slowly.

5. Adjust throttle to operate mower at desired ground speed and transport mower to desired destination.

### PREPARING TO MOW

1. Return traction control lever to DISENGAGE, throttle to SLOW and stop engine.

2. Push kickstand down with foot and pull up on handle to raise wheels off the ground.

3. Push locking clips on wheels out of grooves in shafts and slide wheels off shafts.

4. Release kick stand.

### MOWING OPERATION

Proper use of the Greensmaster 1000 provides the smoothest turf cutting available. The fundamental suggestions given will provide the utmost performance from your mower.

### PRIOR TO MOWING

Remove dew and worm casts from turf prior to mowing by whipping the turf with a bamboo pole or by dragging a hose over the area. Be sure the mower is carefully adjusted and is set evenly on both sides of the reel. Improper mower adjustment is magnified many times over in the appearance of the clipped turf. A three-to-five foot wide "collar" should be mowed around the area at a slightly higher cut than the putting green area. This will provide sufficient space for turning the mower without turning on the green area.

### METHOD OF MOWING

The Greens should be mowed in a straight back and forth direction across the green. Avoid circular mowing or turning the mower on greens areas since scuffing may occur. Turning the mower should be done off the green proper by raising the cutting reel (pushing the handle down) and turning on the traction drum. The greens area should not be mowed in the same direction at any two successive mowings. Cutting in different directions at each mowing will keep the grass growing in an upright position, preventing grain formation. Mowing should be done at a normal walking pace. Fast speeds saves very little time and will result in an inferior mowing job.

3. Move traction lever to ENGAGED position, increase throttle speed until the mower is traveling at the desired ground speed, drive the mower out onto the green area, lower the front of the mower down and commence operation.

# OPERATING INSTRUCTIONS

## CONTROL OPERATION

To operate the controls while mowing:

1. Start the engine, set the throttle at reduced speed, push down on handle to raise cutting unit, move traction lever to ENGAGED position and transport mower onto collar of green.
2. Move traction lever to DISENGAGED position and ENGAGE reel drive lever.

## AFTER MOWING

1. Drive off green, move traction control lever to DISENGAGE, stop the engine and push the reel drive lever into DISENGAGED position.
2. Empty the grass catcher of clippings, install grass catcher and commence transport operation, refer to Transport Operation.

## LUBRICATION

### GREASE FITTINGS

The (13) grease fittings on the mower should be greased at least every 25 hours. Lubricate using No. 2 multi-purpose lithium base grease. A hand operated grease gun is recommended for best results.

1. Wipe each grease fitting with a clean rag.
2. The grease fitting locations are: (2) on Front Roller (Fig. 20), (2) on reel bearings (Fig. 20), (2) on Drum Axles (Fig. 21), (3) on Differential (Fig. 21), (2) on Reel Countershaft Bearings (Fig. 22) and (2) on Belt Idler Pivots (Fig. 23).

**IMPORTANT:** Do not apply too much pressure or grease seals will become permanently damaged.

3. Wipe off excess grease.

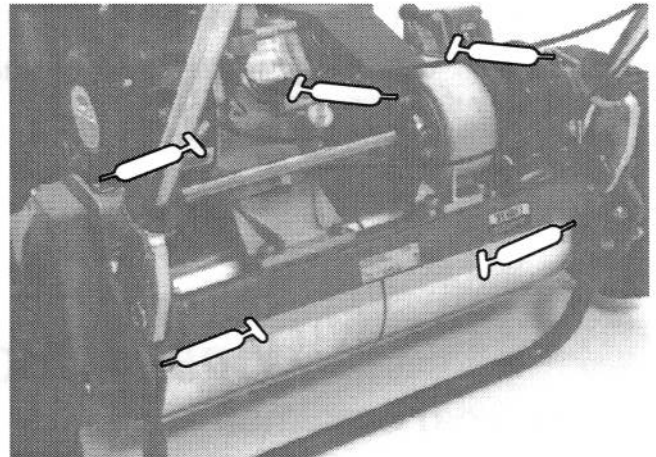

Figure 21

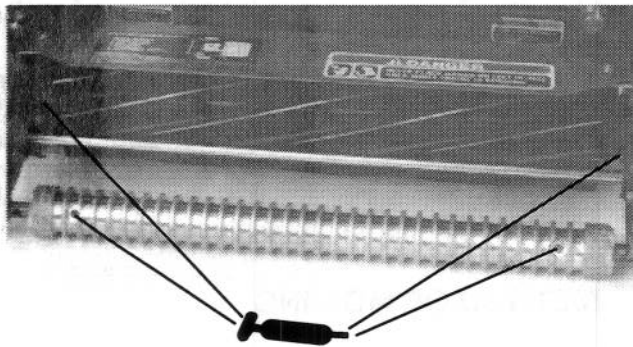

Figure 20

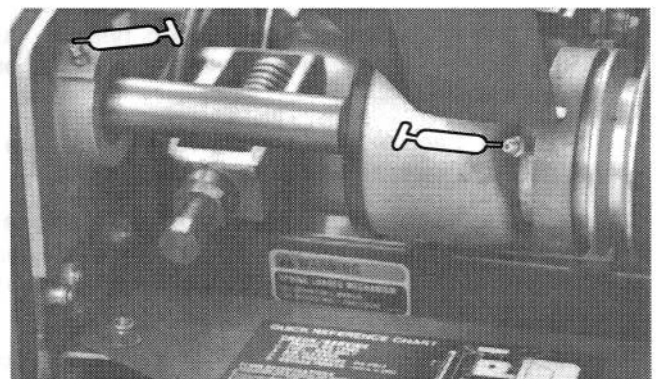

Figure 22

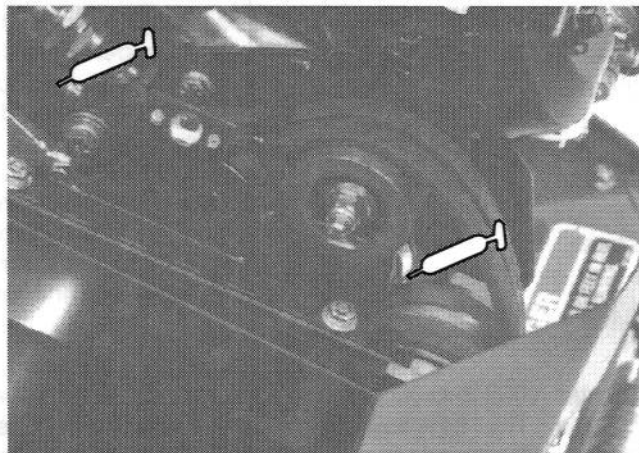

Figure 23

# MAINTENANCE



## CAUTION

Shut engine off, wait for all moving parts to stop and disconnect spark plug wire (Fig. 24) before performing any maintenance procedures on the mower.

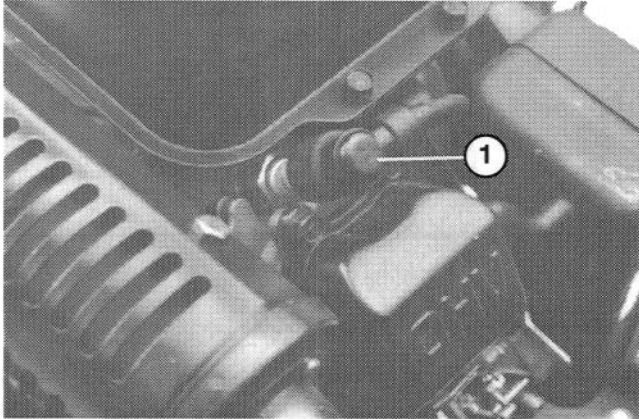

**Figure 24**  
1. Spark Plug

## ENGINE OIL

The TORO Company recommends that the oil level be checked each time mower is used or after every 5 operating hours. Initially, change oil after the first 20 hours of operation; thereafter, change oil after every 50 hours of operation. **More frequent oil changes are required in dusty or dirty conditions.**

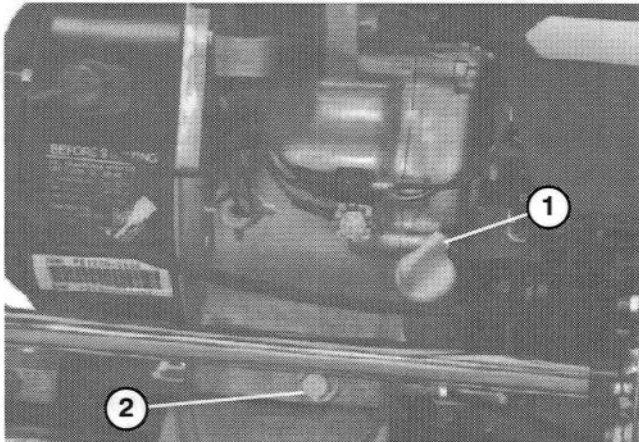

**Figure 25**  
1. Oil level gauge  
2. Drain plug

### To check oil level:

1. Position mower so the engine is level and clean around oil level gauge (Fig. 25).
2. Remove oil level gauge by rotating it counterclockwise.
3. Wipe oil level gauge clean and insert it into filler port. Do not screw into port. Then remove and check

level of oil. If level is low, add only enough oil (see chart below for proper viscosity) to raise level to filler opening.

Use any high quality detergent oil having the American Petroleum Institute (API) "service classification"—MS or SC.

Temperature	Oil Viscosity
50° or below	SAE 10W30 wt.
50° to 95°	SAE 10W30 wt. or 30 wt.
Above 95°	SAE 40

4. Reinstall oil level gauge and wipe up any spilled oil.

### To change oil:

1. Start and run engine for a few minutes to warm the engine oil.
2. Place a drain pan at rear of machine under drain plug (Fig. 25). Remove drain plug.
3. Push down on handle to tip mower and engine backward, allowing more oil to run into drain pan.
4. Reinstall drain plug and refill crankcase with proper oil: refer to Check Oil Level.

## SERVICING AIR CLEANER

Normally, clean air cleaner after every 50 operating hours. More frequent cleaning is required when mower is operated in dusty or dirty conditions.

1. Make sure wire is off spark plug.
2. Remove wing nuts securing air cleaner cover to air cleaner and remove cover. Clean cover thoroughly (Fig. 26).

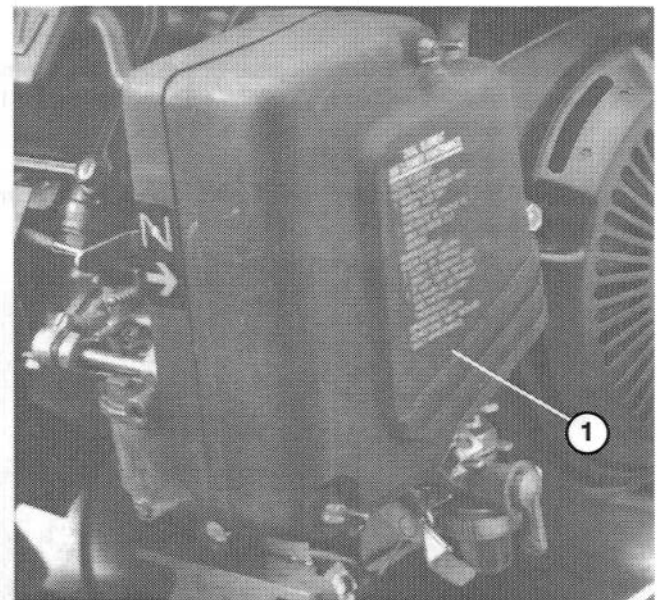

**Figure 26**  
1. Air cleaner cover

3. If foam element is dirty, remove it from paper element (Fig. 27). Clean thoroughly.

# 1 MAINTENANCE

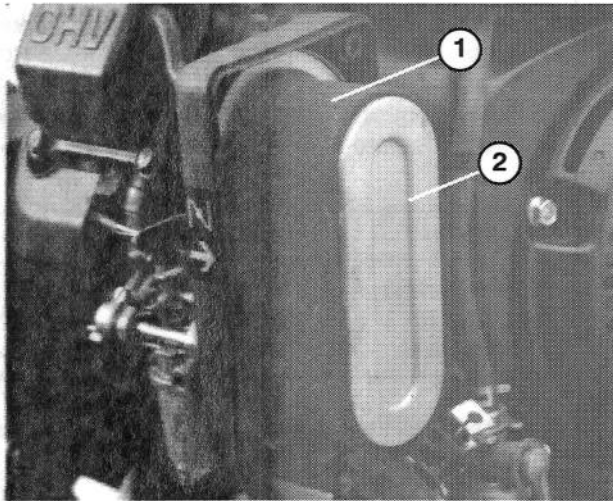

Figure 27

1. Foam element 2. Paper element

**A. WASH** foam element in a solution of liquid soap and warm water. Squeeze to remove dirt, but do not twist because foam may tear.

**B. DRY** by wrapping in a clean rag. Squeeze rag and foam element to dry.

**C. SATURATE** element with clean engine oil. Squeeze element to remove excess oil and to distribute oil thoroughly. An oil damp element is desirable.

4. When servicing foam element, check condition of paper element. Clean or replace as required.

5. Reinstall foam element, paper element and air cleaner cover.

**IMPORTANT: Do not operate engine without air cleaner element because extreme engine wear and damage will likely result.**

## REPLACING SPARK PLUG

Use an **NGK BP 5ES** spark plug or equivalent. Correct air gap is  $0.028'' - 0.031''$ . Remove plug after every 100 operating hours and check its condition.

1. Pull wire off spark plug.

2. Clean around spark plug and remove plug from cylinder head (Fig. 28)

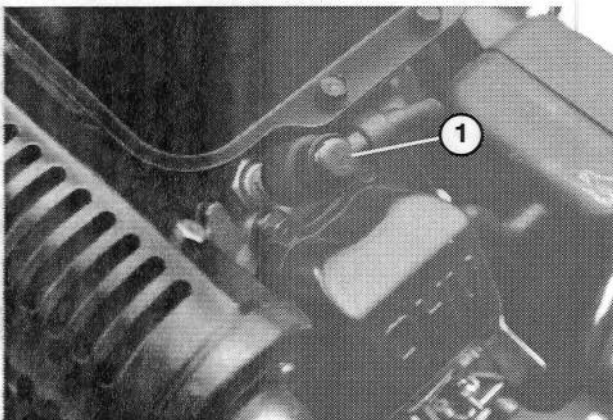

Figure 28

1. Spark plug

**IMPORTANT: Replace a cracked, fouled, or dirty spark plug. Do not sand blast, scrape, or clean electrodes because engine damage could result from grit entering cylinder.**

3. Set air gap at  $0.028'' - 0.031''$  (Fig. 29). Install correctly gapped spark plug and tighten firmly to 20 ft-lb.

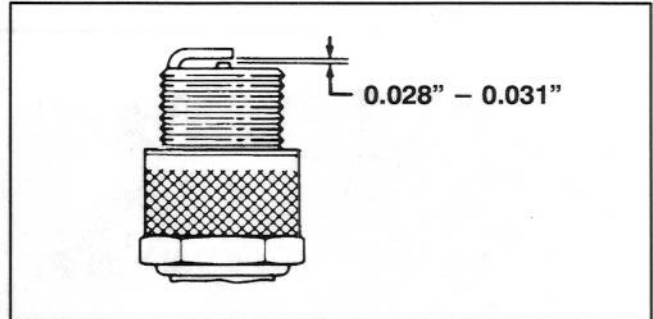

Figure 29

## CLEANING FUEL FILTER

Initially, clean fuel filter after the first 20 hours of operation; thereafter clean after every 50 hours operation.

1. Close fuel shut off valve and unscrew bowl from filter body (Fig. 30).

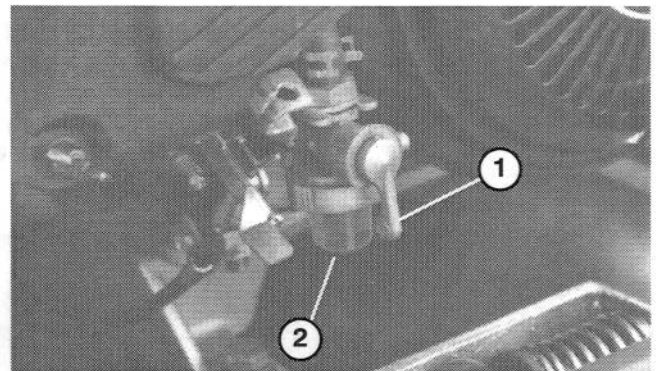

Figure 30

1. Shut off valve  
2. Bowl

2. Clean bowl and filter in clean gasoline and reinstall.

## ADJUSTING BELTS

Make sure belts are properly tensioned to assure proper operation of the machine and unnecessary wear. Check belts frequently.

### Reel Drive belt (Fig. 32)

1. Check tension by depressing belt at mid span of pulleys with  $4 \pm 1$  lbs. of force. Belt should deflect  $1/4$  in. If deflection is incorrect, proceed to next step. If correct, continue operation.

2. To adjust belt tension:

**A.** Remove belt cover mounting screws and belt cover to expose belt.

# MAINTENANCE

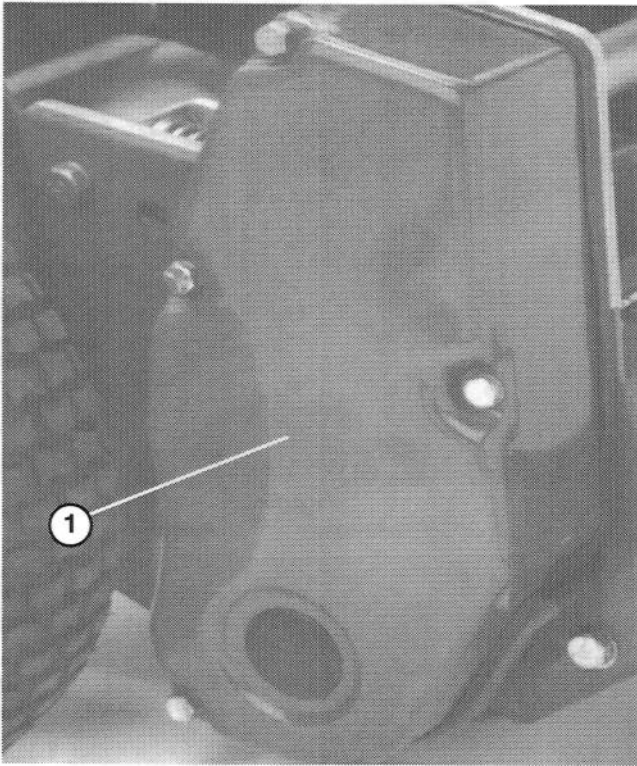

**Figure 31**  
1. Reel drive belt cover

**B.** Loosen idler pulley mounting nut and pivot the idler pulley clockwise against the backside of the belt until desired belt tension is attained. **DO NOT OVER TENSION BELT.**

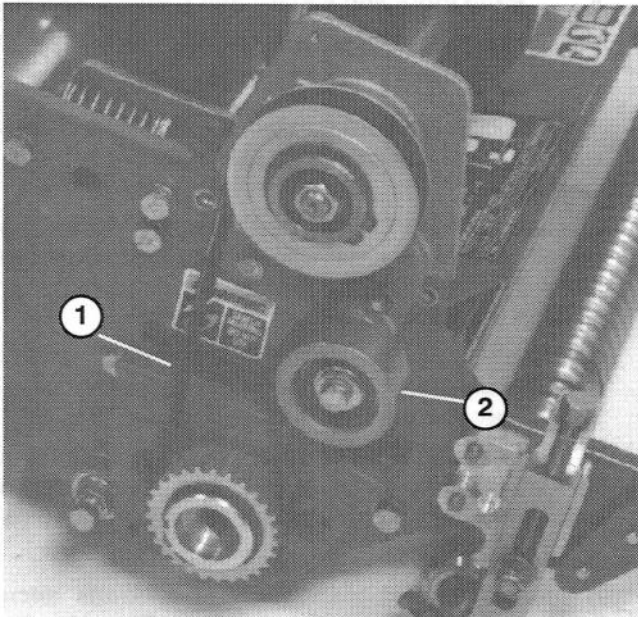

**Figure 32**  
1. Reel drive belt      2. Idler pulley

**C.** Tighten nut to lock adjustment.

**D.** Reinstall belt cover by placing the cover in position. While maintaining a slight gap between the cover seal and the side plate, install each mounting bolt until the threads engage in the insert. The gap will allow visual alignment of the bolt to the threaded insert. After all bolts are installed, tighten until the stand offs inside the cover contact the side plate. Do not overtighten.

## Traction Drive belt (Fig. 33)

1. Check tension by depressing belt at mid span of pulleys with  $4 \pm 1$  lbs. of force. Belt should deflect 1/4 in. If deflection is incorrect, proceed to next step. If correct, continue operation.

2. To adjust belt tension:

**A.** Remove belt cover mounting screws and belt cover to expose belt.

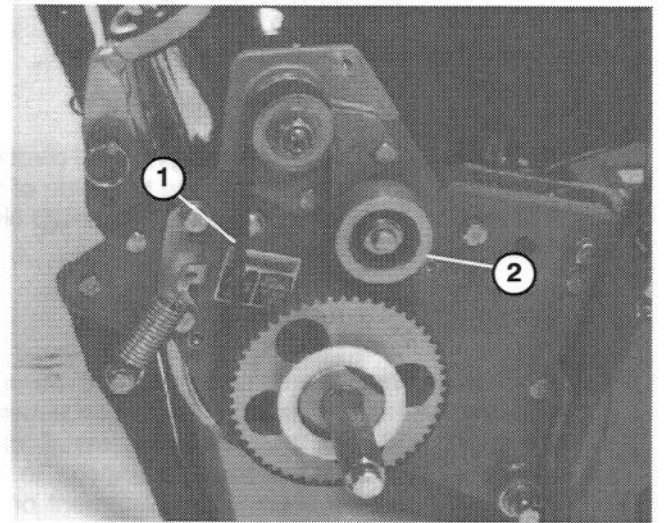

**Figure 33**  
1. Traction drive belt      2. Idler pulley

**B.** Loosen idler pulley mounting nut and pivot the idler pulley clockwise against the backside of the belt until desired belt tension is attained. **DO NOT OVER TENSION BELT.**

**C.** Tighten nut to lock adjustment.

**D.** Reinstall belt cover by placing the cover in position. While maintaining a slight gap between the cover seal and the side plate, install each mounting bolt until the threads engage in the insert. The gap will allow visual alignment of the bolt to the threaded insert. After all bolts are installed, tighten until the stand offs inside the cover contact the side plate. Do not overtighten.

## Differential belt (Fig. 34)

1. Check tension by depressing belt at mid span of pulleys with  $5 \pm 1$  lbs. of force. Belt should deflect 1/4 in. If deflection is incorrect, proceed to next step. If correct, continue operation.

2. To adjust belt tension:

# MAINTENANCE

A. Remove capscrews securing front and rear sections of differential cover to differential housing and slide cover sections away to expose belt.

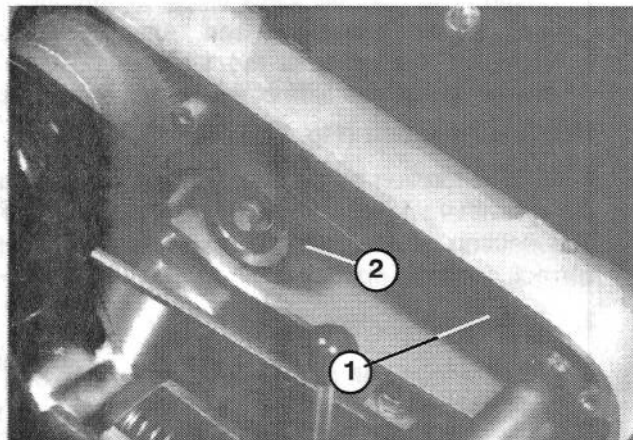

Figure 34

1. Differential belt 2. Idler pulley

B. Loosen idler pulley mounting nut and pivot the idler pulley clockwise against the backside of the belt until desired belt tension is attained. **DO NOT OVER TENSION BELT.**

C. Tighten nut to lock adjustment.

D. Reinstall belt cover by placing the cover in position. While maintaining a slight gap between the cover seal and the side plate, install each mounting bolt until the threads engage in the insert. The gap will allow visual alignment of the bolt to the threaded insert. After all bolts are installed, tighten until the stand offs inside the cover contact the side plate. Do not overtighten.

## Primary v-belts (Fig. 35-36)

1. To adjust belt tension on primary V - belts, first check adjustment of traction control. Refer to Adjusting Traction Control. If unable to attain the 3-5 lbs. force required in adjusting traction control, proceed to next step.

2. Loosen retainer securing v-belt cover and pivot cover open.

3. To increase belt tension, loosen engine mounting bolts and move engine backwards in slots. **DO NOT OVER TENSION BELTS.** Tighten mounting bolts.

4. After tensioning primary v-belts, check alignment of engine output shaft pulley and countershaft pulley with a straight edge. If pulleys are misaligned, loosen screws securing engine mounting base to mower frame and slide engine from side to side until pulleys are aligned within .030".

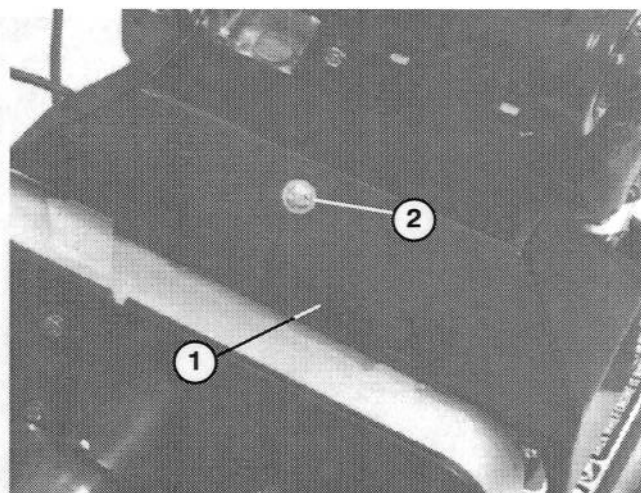

Figure 35

1. V-belt cover 2. Retainer

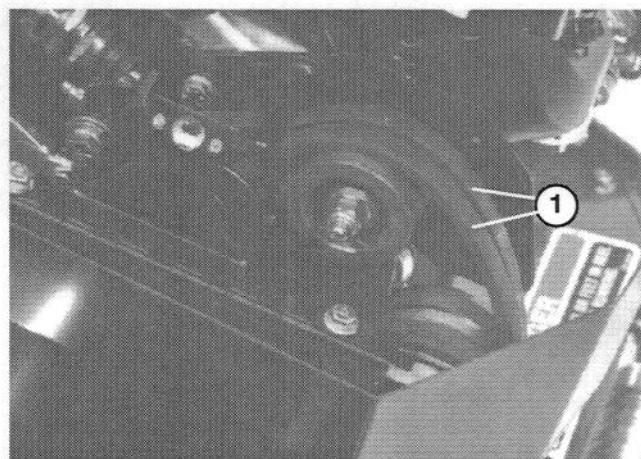

Figure 36

1. Primary V-belts

5. Tighten mounting screws and recheck alignment.

6. Close cover and secure retainer.

## DIFFERENTIAL BELT REPLACEMENT

1. Remove capscrews securing traction drive and reel drive belt covers to right side plate and remove belt covers.

2. Loosen idler pulley mounting nut, on each idler pulley and pivot each idler pulley counterclockwise away from the backside of each belt to release belt tension. Remove belts.

3. Remove capscrews securing front and rear sections of differential cover to differential housing and slide cover sections away to expose belt (Fig. 37).

4. Loosen idler pulley mounting nut, on differential idler pulley and pivot idler pulley counterclockwise away from the backside of belt to release belt tension.

5. Cut old belt and remove from pulleys.

6. Remove (2) capscrews and locknuts securing front clutch housing to side plate (Fig. 37). Rotate housing 180°, so bottom of housing points upward.

7. Remove (2) capscrews and locknuts securing right rear bearing housing to side plate (Fig. 37). Rotate housing 180°, so bottom of housing points upward.

# MAINTENANCE

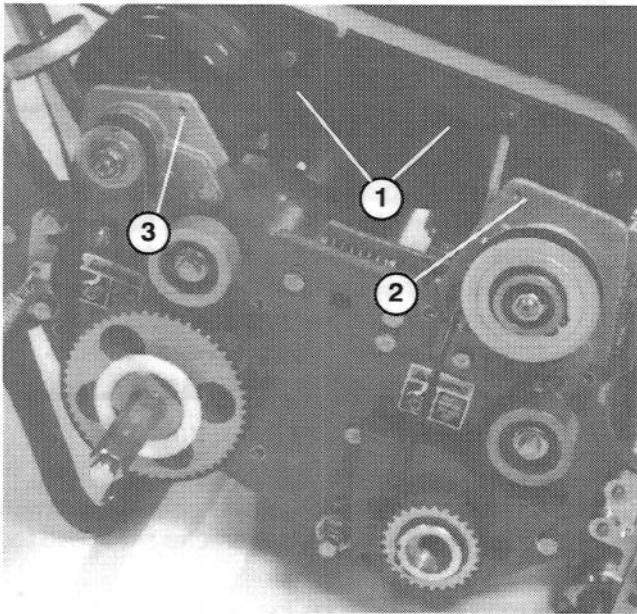

**Figure 37**

1. Differential cover sections
2. Front clutch housing
3. Right rear bearing housing

8. Slide new belt over rotated housing covers, differential cover sections and onto differential pulleys. Make sure idler pulley is positioned against backside of belt.

9. Rotate both housings back into upright position and secure to sideplate with capscrews and nuts previously removed.

10. Adjust differential belt tension, refer to Adjusting Differential belt.

11. Adjust belt tension on traction drive and reel drive belts, refer to Adjusting Traction Drive and Reel Drive belts.

12. Reinstall differential, traction drive and reel drive covers.

## ADJUSTING TRACTION CONTROL

If traction control does not engage or it slips during operation, an adjustment is required.

1. Move traction control to DISENGAGED position.
2. Loosen retainer securing v-belt cover and pivot cover open (Fig. 35).
3. To increase cable tension, loosen front cable jam nut and tighten back cable jam nut (Fig. 38) until a force of 3–5 lbs. is required to engage traction control. Force to be measured at control knob.
4. Tighten front cable jam nut.
5. Close cover and secure retainer.
5. Check control operation.

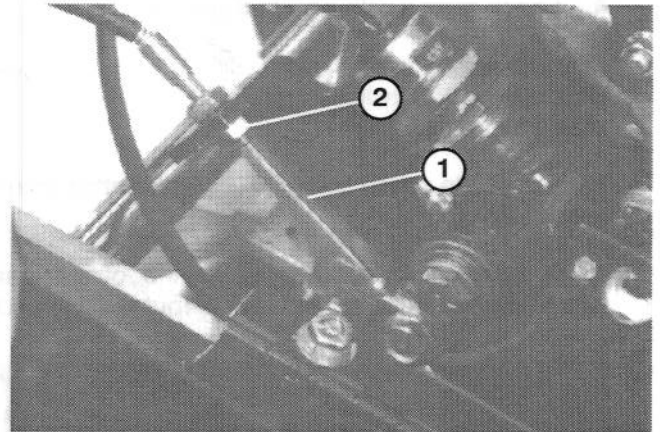

**Figure 38**

1. Traction cable
2. Front jam nut

## ADJUSTING SERVICE / PARK BRAKE

If service/park brake slips when operated, an adjustment is required.

1. Move service/park brake lever to OFF position.
2. Loosen retainer securing v-belt cover and pivot cover open (Fig. 39).

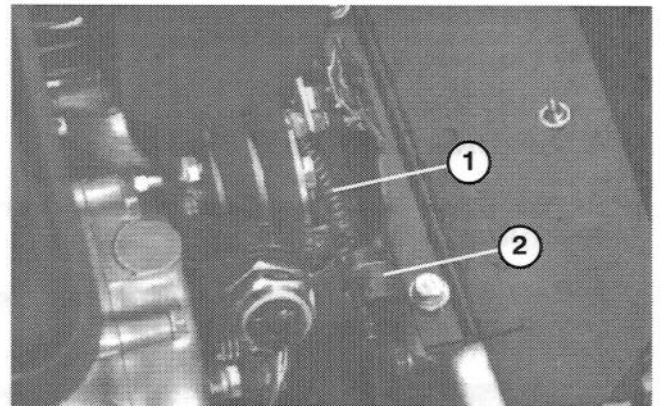

**Figure 39**

1. Service / park brake cable
2. Front jam nut

3. To increase cable tension, loosen front cable jam nut and tighten back cable jam nut (Fig. 38) until a force of 3–5 lbs. is required to engage brake. Force to be measured at lever knob. Do not over adjust, so brake band drags.

4. Close cover and secure retainer.

## ADJUSTING THROTTLE CONTROL

If a new throttle cable must be installed or cable becomes mis-adjusted, adjust as follows:

1. Move throttle control to SLOW position.
2. Loosen screw securing throttle cable to carburetor arm (Fig 40).
3. Arm will move to idle position if improperly adjusted. Tighten screw securing cable to arm. Make sure throttle control is in SLOW position.

# MAINTENANCE

4. Check setting with a tachometer.

**Low idle speed is 800 rpm**  
**High Idle speed is 1800 rpm**  
(See note below)

5. Adjust idle speed screws in or out to attain correct speed setting.

**Note:** Speed is measured at engine output shaft.  
Actual engine speed is twice the output shaft speed.

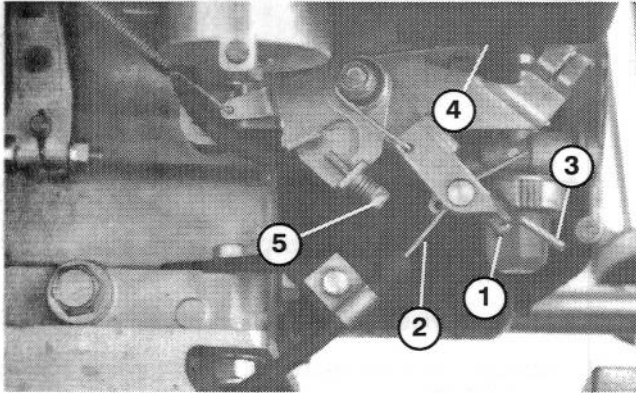

**Figure 40**

- |                         |                          |
|-------------------------|--------------------------|
| 1. Throttle Cable Screw | 4. Low speed idle screw  |
| 2. Throttle cable       | 5. High speed idle screw |
| 3. Carburetor arm       |                          |

## ADJUSTING CARBURETOR

1. Pilot Screw (Fig. 41) - Close screw by gently rotating it clockwise.

**IMPORTANT:** Do not close the screw too tight because carburetor damage will occur.

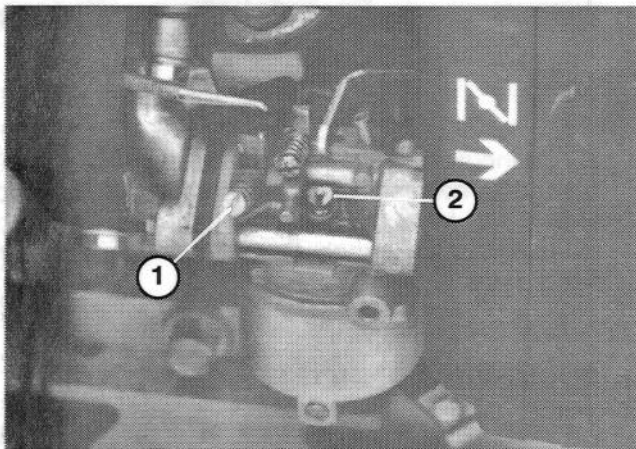

**Figure 41**

- |                               |
|-------------------------------|
| 1. Pilot screw                |
| 2. Carburetor adjusting screw |

2. Rotate -open- pilot screw 1 turn counterclockwise.
3. Turn screw clockwise to lean the mixture and counterclockwise to richen the mixture.

20



## WARNING

Engine must be running so final adjustment of the carburetor can be performed. To guard against possible personal injury, keep hands, feet, face and other parts of the body away from the muffler, other hot parts of the engine, and other moving or rotating parts of the engine. Assure controls are **DISENGAGED** and parking brake is on.

4. Start engine and allow it to warm up.
5. Rotate carburetor adjusting screw (Fig. 41) clockwise to increase speed and counterclockwise to lower idle speed. Using a tachometer set speed to 800 rpm.

## ADJUSTING INTERLOCK SWITCH

Use the following procedure should the switch need adjustment or replacement.

1. Make sure the engine is OFF and traction lever is DISENGAGED.
2. Loosen (2) switch mounting nuts (Fig. 42) and move switch until switch plunger is depressed  $.18 \pm .06$ " (switch closed).
2. Tighten switch mounting nuts.

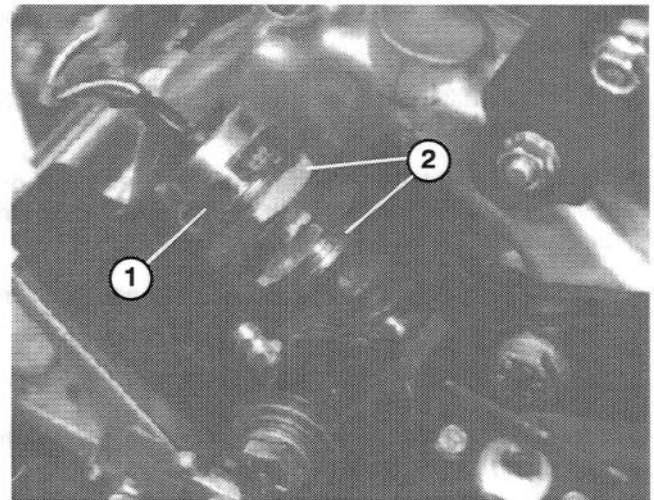

**Figure 42**

- |                     |
|---------------------|
| 1. Interlock switch |
| 2. Mounting nuts    |

3. Engage traction lever and verify that the switch plunger is depressed no more than  $.06$ " (switch open). Readjust as required.

## SERVICING BEDBAR

### REMOVAL

1. Remove grass shield.
2. Loosen jam nut securing each bed bar adjusting screw to each frame adjuster (Fig. 43).

# MAINTENANCE

3. Loosen each bed bar adjusting screw until thrust washer bottoms out on frame adjuster (Fig. 43).

**CAUTION: DO NOT REMOVE BED BAR ADJUSTING SCREWS FROM FRAME ADJUSTERS UNTIL BED BAR HAS BEEN REMOVED, BECAUSE SPRINGS ARE UNDER TENSION AND COULD FLY UPWARD.**

4. Using a spring compressor or clamp, compress springs on bed bar adjusting screws to free bed bar from frame adjusters (Fig. 43).

5. On each side of machine, loosen the jam nut securing bed bar bolt (Fig. 43)

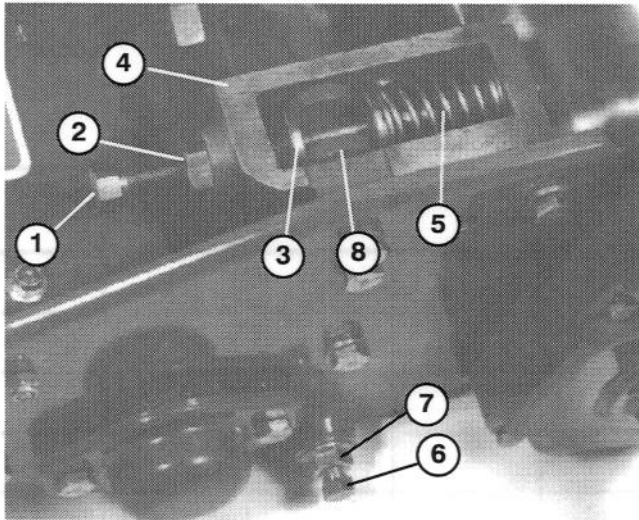

Figure 43

- |                            |                            |
|----------------------------|----------------------------|
| 1. Bed bar adjusting screw | 6. Bed bar bolt            |
| 2. Jam nut                 | 7. Jam nut                 |
| 3. Thrust Washer           | 8. Bed bar (mounting ears) |
| 4. Frame adjuster          |                            |
| 5. Spring                  |                            |

6. Remove each bed bar bolt allowing bed bar to be pulled downward and removed from machine (See figure). Account for (2) thrust washers on each end of bed bar bolt.

**CAUTION: Spring under tension, keeps hands away from top of bed bar when removing bed bar from machine.**

## ASSEMBLY

**NOTE: A spring compressor or clamp may be used to reinstall bed bar mounting ears between thrust washer and thrust collar on bed bar adjusting screw.**

1. Install bed bar, positioning mounting ears between thrust washer and thrust collar on bed bar adjusting screw.

2. Secure bed bar to each side plate with bed bar bolts (flange nuts on bolts) and (2) thrust washers. A thrust washer is to be positioned on each side of side plate boss. Torque bolts to 240 - 320 in-lb. Tighten flange nuts until thrust washers just rotate freely.

3. Reinstall grass shield.

4. Adjust bed bar, refer to Adjust Bedknife to Reel.

## REEL BACKLAPPING

1. Remove plug in right reel drive cover (Fig. 44)

2. Insert a 1/2" socket extension, connected to back lapping machine, into the square hole in the center of reel pulley to backlap.

3. Backlap according to procedure in TORO Sharpening Reel and Rotary Mowers Manual, Form No. 80-300 PT.

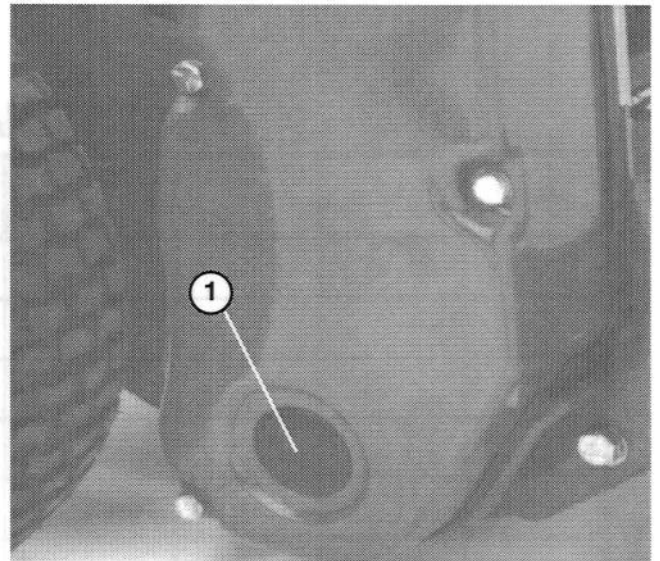

Figure 44  
1. Cover plug



## CAUTION

**Be careful when lapping the reel because contact with reel or other moving parts can result in personal injury.**

**Note:** For a better cutting edge, run a file across the front face of the bedknife when the lapping operation is completed. This will remove any burrs or rough edges that may have built up on the cutting edge.

4. Reinstall plug in cover when backlap operation is completed.



## DANGER

**Under no circumstances use a short handled paint brush for backlapping. 29-9100 Handle assembly complete or individual parts are available from your local Authorized TORO Distributor.**





## The Toro Promise A One Year Limited Warranty

The Toro Company promises to repair your TORO Product if defective in materials or workmanship. The following time periods from the date of purchase apply:

**Commercial Products** ..... **1 Year**

*The cost of parts, labor and transportation are included.*

If you feel your TORO Product is defective and wish to rely on The Toro Promise, the following procedure is recommended:

1. Contact your Authorized TORO Distributor or Commercial Dealer (the Yellow Pages of your telephone directory is a good reference source).
2. The TORO Distributor or Commercial Dealer will advise you on the arrangements that can be made to inspect and repair your product.
3. The TORO Distributor or Commercial Dealer will inspect the product and advise you whether the product is defective and, if so, make all repairs necessary to correct the defect without an extra charge to you.

If for any reason you are dissatisfied with the distributor's analysis of the defect or the service performed, you may contact us.

Write:

TORO Commercial Products Service Department  
8111 Lyndale Avenue South  
Minneapolis, MN 55420

The above remedy of product defects through repair by an Authorized TORO Distributor or Commercial Dealer is the purchaser's sole remedy for any defect.

**THERE IS NO OTHER EXPRESS WARRANTY. ALL IMPLIED WARRANTIES OF MERCHANTABILITY AND FITNESS FOR USE ARE LIMITED TO THE DURATION OF THE EXPRESS WARRANTY.**

Some states do not allow limitations on how long an implied warranty lasts, so the above limitation may not apply to you.

This Warranty applies only to parts or components which are defective and does not cover repairs necessary due to normal wear, misuse, accidents, or lack of proper maintenance. Regular, routine maintenance of the unit to keep it in proper operating condition is the responsibility of the owner.

All warranty repairs reimbursable under The Toro Promise must be performed by an Authorized Toro Commercial Dealer or Distributor using Toro approved replacement parts.

Repairs or attempted repairs by anyone other than an Authorized TORO Distributor or Commercial Dealer are not reimbursable under the TORO Promise. In addition, these unauthorized repair attempts may result in additional malfunctions, the correction of which is not covered by warranty.

**THE TORO COMPANY IS NOT LIABLE FOR INDIRECT, INCIDENTAL OR CONSEQUENTIAL DAMAGES IN CONNECTION WITH THE USE OF THE PRODUCT INCLUDING ANY COST OR EXPENSE OF PROVIDING SUBSTITUTE EQUIPMENT OR SERVICE DURING PERIODS OF MALFUNCTION OR NON-USE.**

Some states do not allow the exclusion of incidental or consequential damages, so the above exclusion may not apply to you.

This warranty gives you specific legal rights, and you may also have other rights which vary from state to state.

### COUNTRIES OTHER THAN THE UNITED STATES OR CANADA

Customers who have purchased TORO products exported from the United States or Canada should contact their TORO Distributor (Dealer) to obtain guarantee policies for your country, province, or state. If for any reason you are dissatisfied with your Distributor's service or have difficulty obtaining guarantee information, contact the TORO importer. If all other remedies fail, you may contact us at The Toro Company.