



**Count on it.**

**Operator's Manual**

**Workman® HDX-D Utility Vehicle  
with Bed**

Model No. 07385—Serial No. 315000001 and Up

Model No. 07385H—Serial No. 315000001 and Up

Model No. 07385TC—Serial No. 315000001 and Up

Model No. 07387—Serial No. 315000001 and Up

Model No. 07387H—Serial No. 315000001 and Up

Model No. 07387TC—Serial No. 315000001 and Up



## ⚠ WARNING

### CALIFORNIA Proposition 65 Warning

This product contains a chemical or chemicals known to the State of California to cause cancer, birth defects, or reproductive harm.

Diesel engine exhaust and some of its constituents are known to the State of California to cause cancer, birth defects, and other reproductive harm.

This machine is a utility vehicle intended to be used by professional, hired operators in commercial applications. It is primarily designed for the transport of implements used in such applications. This vehicle allows for the safe transport of an operator and one passenger in the identified seats. The bed of this vehicle is not suitable for any riders.

This product complies with all relevant European directives; for details, please see the separate product specific Declaration of Conformity (DOC) sheet.

**Important:** The engine in this product is not equipped with a spark arrested muffler. It is a violation of California Public Resource code Section 4442 to use or operate this engine on any forest-covered, brush covered, or grass-covered land as defined in CPRC 4126. Other states or federal areas may have similar laws.

## Introduction

Read this information carefully to learn how to operate and maintain your product properly and to avoid injury and product damage. You are responsible for operating the product properly and safely.

You may contact Toro directly at [www.Toro.com](http://www.Toro.com) for product safety and operation training materials, accessory information, help finding a dealer, or to register your product.

Whenever you need service, genuine Toro parts, or additional information, contact an Authorized Service Dealer or Toro Customer Service and have the model and serial numbers of your product ready. [Figure 1](#) identifies the location of the model and serial numbers on the product. Write the numbers in the space provided.

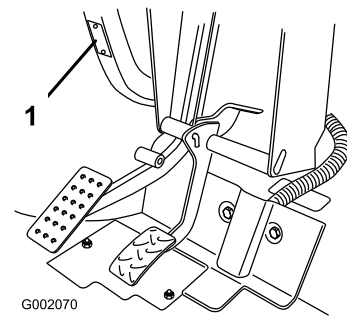

Figure 1

1. Model and serial number location

Model No. \_\_\_\_\_

Serial No. \_\_\_\_\_

This manual identifies potential hazards and has safety messages identified by the safety alert symbol ([Figure 2](#)), which signals a hazard that may cause serious injury or death if you do not follow the recommended precautions.



Figure 2

1. Safety alert symbol

This manual uses 2 words to highlight information.

**Important** calls attention to special mechanical information and **Note** emphasizes general information worthy of special attention.

# Contents

Safety .....	4	Raising the Machine.....	36
Operation.....	4	Removing the Hood .....	37
Sound Pressure .....	6	Installing the Hood.....	37
Vibration.....	6	Lubrication .....	38
Safety and Instructional Decals .....	7	Greasing the Bearings and Bushings .....	38
Setup .....	12	Engine Maintenance .....	40
1 Installing the Steering Wheel (TC models only) .....	12	Servicing the Air Cleaner .....	40
2 Installing the Rollover Protection System (ROPS) .....	12	Changing the Engine Oil and Filter .....	40
3 Checking the Fluid Levels .....	13	Fuel System Maintenance .....	41
Product Overview .....	14	Checking the Fuel Lines and Connections .....	41
Controls .....	14	Servicing the Fuel Filter/Water Separator.....	41
Specifications .....	17	Electrical System Maintenance .....	42
Attachments/Accessories.....	17	Servicing the Fuses .....	42
Operation .....	18	Jump Starting the Machine.....	43
Operating the Cargo Box.....	18	Servicing the Battery .....	44
Checking the Engine-oil Level.....	19	Drive System Maintenance .....	44
Adding Fuel.....	20	Changing the Front-differential Oil (4-wheel drive models only) .....	44
Checking the Coolant Level .....	21	Inspecting the Constant-velocity Boot (4-wheel drive models only).....	44
Checking the Transaxle/Hydraulic-fluid Level.....	21	Adjusting the Shift Cables.....	45
Checking the High Flow Hydraulic-fluid Level (TC models only) .....	22	Adjusting the High-to-Low Cable .....	45
Checking the Front-differential-oil Level (4-wheel drive models only).....	22	Adjusting Differential-lock Cable.....	45
Checking the Torque of the Wheel Nuts.....	23	Inspecting the Tires .....	45
Checking the Tire Pressure .....	23	Checking the Front Wheel Alignment.....	46
Checking the Brake-fluid Level.....	23	Cooling System Maintenance .....	47
Starting the Engine .....	24	Removing Debris from the Cooling System .....	47
Driving the Vehicle.....	24	Changing the Engine Coolant.....	47
Stopping the Machine .....	25	Brake Maintenance .....	48
Stopping the Engine .....	25	Adjusting the Parking Brake .....	48
Breaking in a New Machine.....	25	Adjusting the Brake Pedal .....	49
Checking the Safety-interlock System .....	25	Belt Maintenance .....	50
Ensuring Passenger Safety .....	26	Adjusting the Alternator Belt .....	50
Ensuring Proper Speed .....	26	Controls System Maintenance .....	50
Ensuring Proper Turning.....	26	Adjusting the Accelerator Pedal.....	50
Ensuring Proper Braking.....	26	Adjusting the Clutch Pedal .....	51
Preventing Tip Overs.....	27	Converting the Speedometer.....	51
Operating on Hills.....	27	Hydraulic System Maintenance .....	52
Loading and Dumping .....	27	Changing the Hydraulic fluid and Cleaning the Strainer.....	52
Using the Differential Lock.....	28	Replacing the Hydraulic Filter .....	52
Using 4-wheel Drive (4-wheel drive models only) .....	28	Changing the High-flow Hydraulic fluid and Filter (TC models only).....	53
Transporting the Machine.....	28	Raising the Cargo Box in an Emergency .....	53
Towing the Machine .....	29	Cleaning .....	55
Towing a Trailer with the Machine.....	29	Washing the Machine .....	55
Using the Hydraulic Control .....	29	Storage .....	55
Maintenance .....	32		
Recommended Maintenance Schedule(s) .....	32		
Operating in Adverse Conditions.....	33		
Pre-maintenance Procedures .....	34		
Using the Bed Support .....	34		
Removing the Full Bed.....	35		
Installing the Full Bed .....	35		

# Safety

Improper use or maintenance by the operator or owner can result in injury. To reduce the potential for injury, comply with these safety instructions and always pay attention to the safety alert symbol, which means **Caution, Warning, or Danger**—“personal safety instruction.” Failure to comply with the instruction may result in personal injury or death.

## Operation

- The operator and passenger must use seat belts and remain seated whenever the machine is in motion. The operator should keep both hands on the steering wheel, whenever possible, and the passenger should use the hand holds provided. Keep arms and legs within the vehicle body at all times. Never carry passengers in the box or on attachments. Remember your passenger may not be expecting you to brake or turn and may not be ready.
  - Never overload your machine. The name plate (located under the middle of the dash) shows the load limits for the machine. Never overfill attachments or exceed the machine maximum gross vehicle weight (GVW).
  - When starting the engine:
    - Sit on the operator’s seat and ensure that the parking brake is engaged.
    - Disengage PTO (if so equipped) and return the hand throttle lever to the Off position (if so equipped).
    - Make sure the hydraulic-lift lever is in the center position.
    - Move shift lever to Neutral and press the clutch pedal.
    - Keep your foot off of the accelerator pedal.
    - Turn starter switch to the On position. When the glow plug indicator goes off, the engine is ready to start.
    - Turn the starter key to the Start position.
- Note:** The glow-plug indicator will turn on, for an additional 15 seconds, when the switch returns to the Start position.
- Using the machine demands attention. Failure to operate machine safely may result in an accident, tip over of the machine, and serious injury or death. Drive carefully. To prevent tipping or loss of control, take the following precautions:
    - Use extreme caution, reduce speed, and maintain a safe distance around sand traps, ditches, creeks, ramps, any unfamiliar areas, or other hazards.
    - Watch for holes or other hidden hazards.
    - Use caution when operating the machine on a steep slope. Normally, travel straight up and down slopes. Reduce speed when making sharp turns or when turning on hillsides. Avoid turning on hillsides whenever possible.
- Use extra caution when operating the vehicle on wet surfaces, at higher speeds, or with a full load. Stopping time will increase with a full load. Shift into a lower gear before starting up or down a hill.
  - When loading the bed, distribute the load evenly. Use extra caution if the load exceeds the dimensions of the machine/bed. Operate the vehicle with extra caution when handling off-center loads that cannot be centered. Keep loads balanced and secure to prevent them from shifting.
  - Avoid sudden stops and starts. Do not go from reverse to forward or forward to reverse without first coming to a complete stop.
  - Do not attempt sharp turns or abrupt maneuvers or other unsafe driving actions that may cause a loss of machine control.
  - Do not pass another machine traveling in the same direction at intersections, blind spots, or at other dangerous locations.
  - When dumping, do not let anyone stand behind the machine, and do not dump the load on any one’s feet. Release the tailgate latches from the side of box, not from behind.
  - Keep all bystanders away. Before backing up, look to the rear and ensure that no one is behind the machine. Back up slowly.
  - Watch out for traffic when near or crossing roads. Always yield the right of way to pedestrians and other machines. This machine is not designed for use on streets or highways. Always signal your turns or stop early enough so other persons know what you plan to do. Obey all traffic rules and regulations.
  - Never operate the machine in or near an area where there is dust or fumes in the air which are explosive. The electrical and exhaust systems of the machine can produce sparks capable of igniting explosive materials.
  - Always watch out for and avoid low overhangs such as tree limbs, door jambs, over head walkways, etc. Make sure there is enough room over head to easily clear the machine and your head.
  - If ever unsure about safe operation, **stop work**, and ask your supervisor.
- Do not touch the engine, transaxle, radiator, muffler, or muffler manifold while engine is running or soon after it has stopped because these areas may be hot enough to cause burns.
  - If the machine ever vibrates abnormally, stop immediately, turn engine off, wait for all motion to stop and inspect for damage. Repair all damage before resuming operation.
  - Before getting off of the seat:
    1. Stop the movement of the machine.
    2. Set the parking brake.
    3. Turn the starter key to the Off position.

4. Remove the starter key.

**Note:** If the machine is on an incline, block the wheels after getting off of the machine.

- Lightning can cause severe injury or death. If lightning is seen or thunder is heard in the area, do not operate the machine; seek shelter.

## Braking

- Slow down before you approach an obstacle. This gives you extra time to stop or turn away. Hitting an obstacle can injure you and your passenger. In addition, it can damage the machine and its contents.
- Gross Vehicle Weight (GVW) has a major impact on your ability to stop and/or turn. Heavy loads and attachments make the machine harder to stop or turn. The heavier the load, the longer it takes to stop.
- Decrease the speed of the machine if the cargo box has been removed and there is no attachment installed on the machine. The braking characteristics change and fast stops may cause the rear wheels to lock up, which will affect the control of the machine.
- Turf and pavement are much more slippery when they are wet. It can take 2 to 4 times longer to stop the machine on wet surfaces as on dry surfaces. If you drive through deep-standing water and get the brakes wet, they will not work well until they are dry. After driving through water, you should test the brakes to make sure they work properly. If they do not, drive slowly on a level ground while putting light pressure on the brake pedal. This will dry the brakes out.

## Operating on Hills

### **⚠ WARNING**

Operating the machine on a hill may cause tipping or rolling of the machine, or the engine may stall and you could lose headway on the hill. This could result in personal injury.

- Do not operate machine on excessively steep slopes.
- Do not accelerate quickly or slam on the brakes when backing down a hill, especially with a load.
- If the engine stalls or you lose headway on a hill, slowly back straight down the hill. Never attempt to turn the machine around.
- Operate the machine slowly on a hill and use caution.
- Avoid turning on a hill.
- Reduce your load and the speed of the machine.
- Avoid stopping on hills, especially with a load.

These extra cautions need to be taken when operating the machine on a hill:

- Slow the machine down before starting up or down a hill.
- If the engine stalls or you begin to lose momentum while climbing a hill, gradually apply the brakes and slowly back the machine straight down the hill.
- Turning while traveling up or down hills can be dangerous. If you have to turn while on a hill, do it slowly and cautiously. Never make sharp or fast turns.
- Heavy loads affect stability. Reduce the weight of the load and your ground speed when operating on hills or if the load has a high center of gravity. Secure the load to the cargo box of the machine to prevent the load from shifting. Take extra care when hauling loads that shift easily (liquid, rock, sand, etc.).
- Avoid stopping on hills, especially with a load. Stopping while going down a hill will take longer than stopping on level ground. If the machine must be stopped, avoid sudden speed changes, which may initiate tipping or rolling of the machine. Do not slam on the brakes when rolling backward, as this may cause the machine to overturn.
- If you will be using the machine on hilly terrain, you can install the optional ROPS Kit.

## Operating on Rough Terrain

Reduce the ground speed of the machine and load carried in the machine when operating on rough terrain, uneven ground, and near curbs, holes, and other sudden changes in terrain. Loads may shift, causing the machine to become unstable.

If you will be using the machine on rough terrain, you can install the optional ROPS Kit.

### **⚠ WARNING**

Sudden changes in terrain may cause abrupt steering wheel movement, possibly resulting in hand and arm injuries.

- Reduce your speed when operating on rough terrain and near curbs.
- Grip the steering wheel loosely around the perimeter keeping thumbs up and out of the way of the steering wheel spokes.

## Loading and Dumping

The weight and position of cargo and passenger can affect the stability and handling of the machine. Be aware of the following condition to avoid losing control of the machine or tipping it over:

- Do not exceed the rated weight capacity of the machine when operating it with a load in the cargo box, when towing a trailer, or both; refer to [Specifications \(page 17\)](#).
- Use caution when operating the machine on a hillside or on rough terrain, particularly with a load in the cargo box or when towing a trailer or both.
- Use caution when carrying tall loads in the cargo box.

- Be aware that the stability and control of the machine are reduced when the load in the cargo box is poorly distributed.
- Carrying oversized loads in the cargo box changes the stability of the machine.
- The steering, braking, and stability of the machine are affected when carrying a load where the weight of the material cannot be bound to the machine such as the liquid in a large tank.

## **⚠ WARNING**

**The weight of the box may be heavy. Hands or other body parts could be crushed.**

- **Keep hands and other body parts clear when lowering the box.**
- **Do not dump materials on bystanders.**
- Never dump a loaded cargo box while the machine is sideways on a hill. The change in weight distribution may cause the machine to overturn.
- When operating with a heavy load in the cargo box, reduce your speed and allow for sufficient braking distance. Do not suddenly apply the brakes. Use extra caution on slopes.
- Be aware that heavy loads increase your stopping distance and reduce your ability to turn quickly without tipping over.
- The rear cargo space is intended for load carrying purposes only, not for passengers.
- Never overload your machine. The name plate (located under the middle of the dash) shows the load limits for the machine. Never overfill attachments or exceed the machine maximum gross vehicle weight (GVW).

## **Whole Body**

- Measured vibration level =  $0.3 \text{ m/s}^2$
- Uncertainty Value (K) =  $0.5 \text{ m/s}^2$

Measured values were determined according to the procedures outlined in EN 1032.

## **Sound Pressure**

This unit has a sound pressure level at the operator's ear of 82 dBA, which includes an Uncertainty Value (K) of 1 dBA.

The sound pressure level was determined according to the procedures outlined in EN ISO 11201.

## **Vibration**

### **Hand-Arm**

- Measured vibration level for right hand =  $0.41 \text{ m/s}^2$
- Measured vibration level for left hand =  $0.2 \text{ m/s}^2$
- Uncertainty Value (K) =  $0.5 \text{ m/s}^2$

Measured values were determined according to the procedures outlined in EN 1032.

# Safety and Instructional Decals



Safety decals and instructions are easily visible to the operator and are located near any area of potential danger. Replace any decal that is damaged or lost.

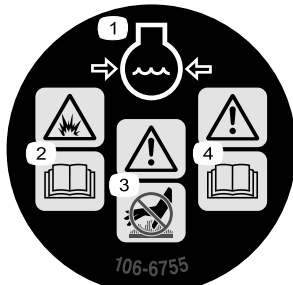

**106-6755**

1. Engine coolant under pressure.
2. Explosion hazard—read the *Operator's Manual*.
3. Warning—do not touch the hot surface.
4. Warning—read the *Operator's Manual*.

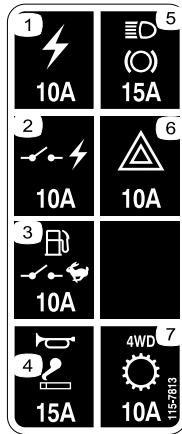

**115-7813**

1. Power outlet—10A
2. Switched power—10A
3. Fuel pump, supervisor switch—10A
4. Horn, power point—15A
5. Lights, brake—15A
6. Hazard—10A
7. 4WD, Transmission—10A

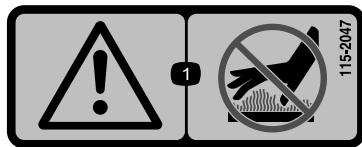

**115-2047**

1. Warning—do not touch the hot surface.

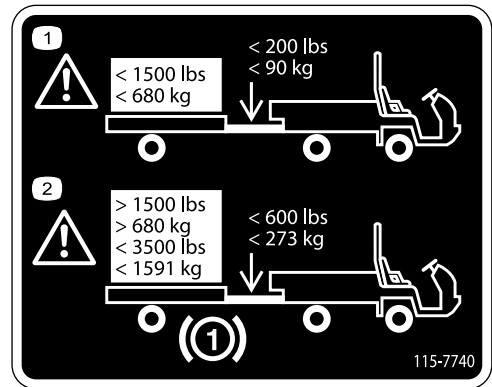

**115-7740**

1. Warning—maximum trailer weight is 680 kg (1500 lb), maximum tongue weight is 90 kg (200 lb).
2. Warning—trailer brakes are required when towing greater than 680 kg (1500 lb), maximum trailer weight with trailer brakes is 1591 kg (3500 lb), maximum tongue weight with trailer brakes is 273 kg (600 lb).

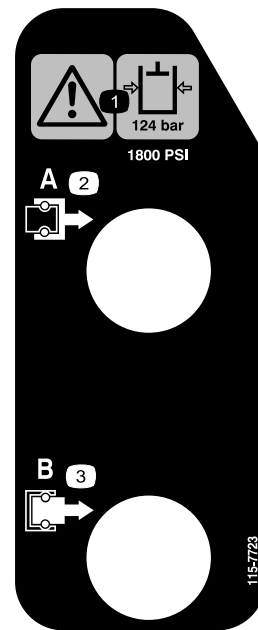

**115-7723**

1. Warning—the hydraulic oil pressure is 124 bar (1800 psi).
2. Coupler A
3. Coupler B



115-2282

1. Warning—read the *Operator's Manual*.
2. Warning—stay away from moving parts, keep all guards and shields in place.
3. Crushing/dismemberment hazard of bystanders—keep bystanders a safe distance from the vehicle, do not carry passengers in the cargo bed, keep arms and legs inside of the vehicle at all times, and use seat belts and handholds.



115-7746

1. Warning—do not operate this machine unless you are trained.
2. Warning—lock the parking brake, stop the engine, and remove the starter key before leaving the machine.
3. Fire hazard—stop the engine before fueling.
4. Tipping hazard—slow down and turn gradually, use caution and drive slowly when driving on slopes, do not exceed 32 kph (20 mph), and drive slowly over rough terrain or when carrying a full or heavy load.

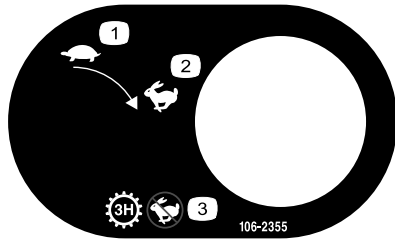

106-2355

1. Slow
2. Fast
3. Transmission—third high; no fast speed

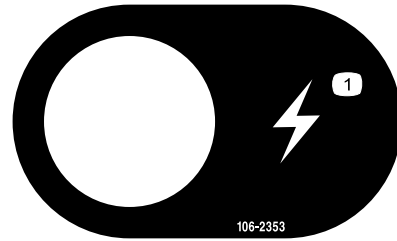

106-2353

1. Electrical power point

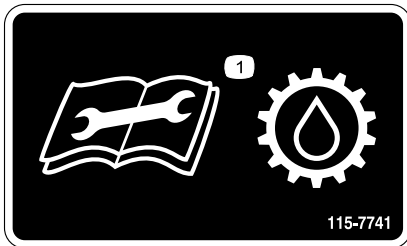

115-7741

1. Read the *Operator's Manual* before servicing transmission fluid.

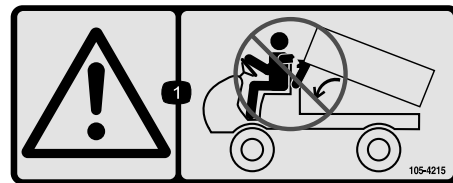

105-4215

1. Warning—avoid pinch points.

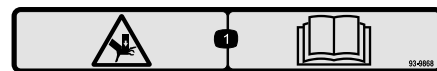

93-9868

1. Crushing hazard of hand—read the *Operator's Manual*.





**Battery Symbols**

Some or all of these symbols are on your battery

- |  |  |
|--|--|
| 1. Explosion hazard                    | 6. Keep bystanders a safe distance from the battery.                           |
| 2. No fire, open flame, or smoking.    | 7. Wear eye protection; explosive gases can cause blindness and other injuries |
| 3. Caustic liquid/chemical burn hazard | 8. Battery acid can cause blindness or severe burns.                           |
| 4. Wear eye protection                 | 9. Flush eyes immediately with water and get medical help fast.                |
| 5. Read the <i>Operator's Manual</i> . | 10. Contains lead; do not discard.   |

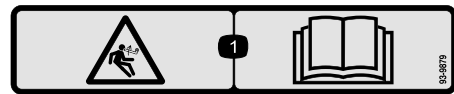

**93-9879**

1. Stored energy hazard—read the *Operator's Manual*.

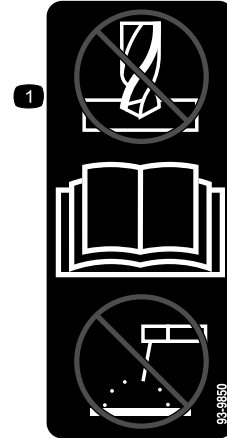

**93-9850**

1. Do not repair or revise—read the *Operator's Manual*.

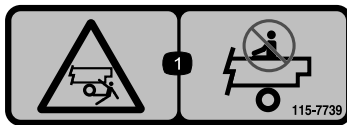

**115-7739**

1. Falling, crushing hazard, bystanders—no riders on machine.



**93-9899**

1. Crushing hazard—install the cylinder lock.



**115-7756**

1. High flow hydraulics—engaged



**106-7767**

1. Warning—read the *Operator's Manual*; avoid tipping the machine; wear the seat belt; lean away from the direction the machine is tipping.

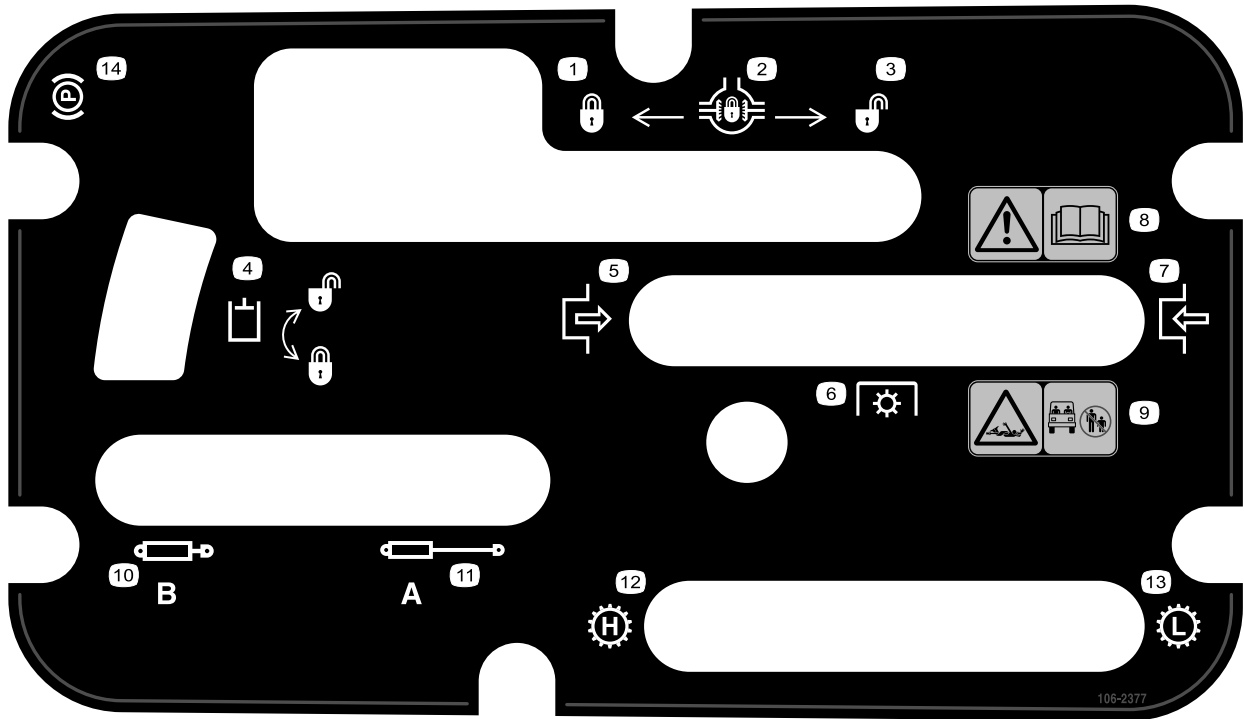

**106-2377**

- |                         |  |
|-------------------------|--|
| 1. Locked               | 8. Warning—read the <i>Operator's Manual</i> .                                   |
| 2. Differential lock    | 9. Entanglement hazard, shaft—keep bystander's a safe distance from the vehicle. |
| 3. Unlocked             | 10. Retract hydraulics   |
| 4. Hydraulic lock       | 11. Extend hydraulics  |
| 5. Engage               | 12. Transmission—high speed  |
| 6. Power take-off (PTO) | 13. Transmission—low speed   |
| 7. Disengage            | 14. Parking brake  |

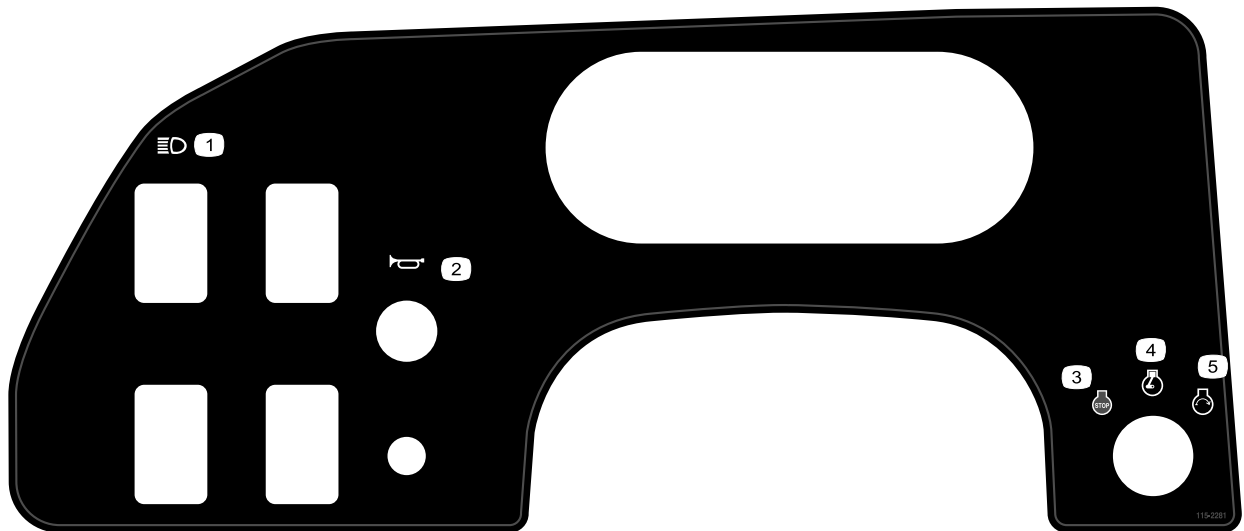

**115-2281**

- |                |                 |
|----------------|-----------------|
| 1. Headlights  | 4. Engine—run   |
| 2. Horn        | 5. Engine—start |
| 3. Engine—stop |                 |

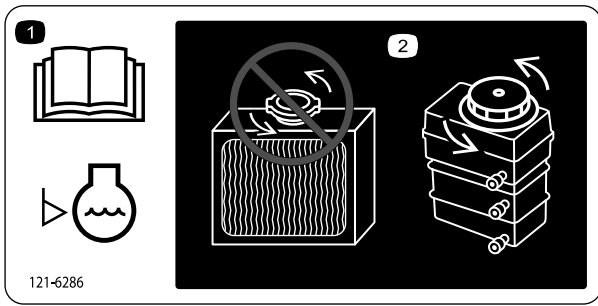

**121-6286**

1. Read the *Operator's Manual* before checking the engine coolant level.
2. Do not add engine coolant to the radiator; add engine coolant to the reservoir,

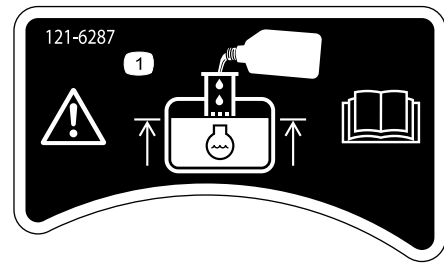

**121-6287**

1. Fill the reservoir with engine coolant to the bottom of the standpipe.



**93-9852**

1. Warning—read the *Operator's Manual*.
2. Crushing hazard—install the cylinder lock.

# Setup

## Loose Parts

Use the chart below to verify that all parts have been shipped.

Procedure	Description	Qty.	Use
<b>1</b>	Steering wheel	1	Install the steering wheel (TC models only).
<b>2</b>	ROPS frame Bolt (1/2 inch)	1 6	Mount the Rollover Protection System (ROPS).
<b>3</b>	No parts required	–	Check the engine oil, the transaxle/hydraulic fluid, and the brake fluid levels.

**Note:** Determine the left and right side of the machine from the normal operating position.



## Installing the Steering Wheel (TC models only)

### Parts needed for this procedure:

1	Steering wheel
---	----------------

### Procedure

1. Release the tabs on the back of the steering wheel that hold the center cover in place, and remove the cover from the hub of the steering wheel.
2. Remove the locknut and washer from the steering shaft.
3. Slide the steering wheel and washer onto the shaft. Align the steering wheel on the shaft so that the cross beam is horizontal when the tires are pointed straight ahead and the thicker spoke of the steering wheel is downward.

**Note:** The dust cover is position onto the steering shaft at the factory.

4. Secure the steering wheel to the shaft with the locknut (Figure 3). Torque the locknut to 24 to 29 N-m (18 to 22 ft-lb)

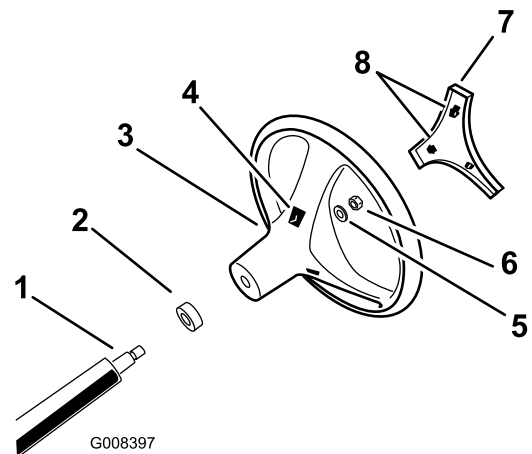

**Figure 3**

- |                       |                  |
|-----------------------|------------------|
| 1. Steering shaft     | 5. Washer        |
| 2. Dust cover         | 6. Locknut       |
| 3. Steering wheel     | 7. Cover         |
| 4. Tab slots in wheel | 8. Tabs in cover |
- 
5. Align the tabs of the cover with the slots in the steering wheel, and snap the cover onto the steering-wheel hub (Figure 3).

# 2

## Installing the Rollover Protection System (ROPS)

### Parts needed for this procedure:

1	ROPS frame
6	Bolt (1/2 inch)

### Procedure

1. Align each side of the ROPS with the mounting holes in the frame at each side of the vehicle as shown in [Figure 4](#).

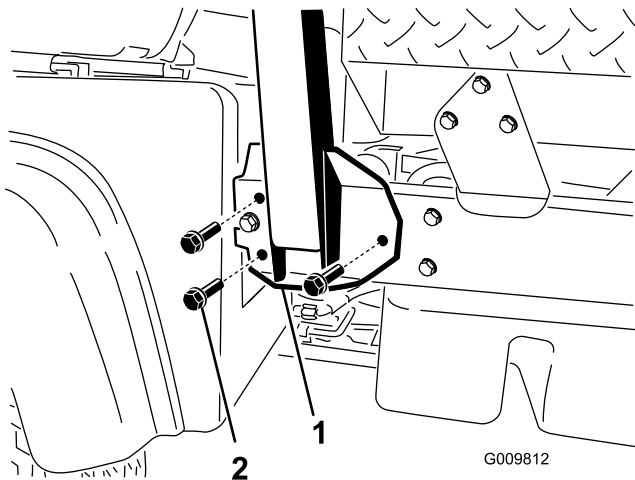

**Figure 4**

1. ROPS-mounting bracket
2. Flanged bolts (1/2 x 1-1/4 inch)

2. Secure each side of the ROPS to frame with 3 flanged bolts (1/2 x 1-1/4 inch), and tighten the bolts to 115 N-m (85 ft-lb).

# 3

## Checking the Fluid Levels

### No Parts Required

### Procedure

1. Check the engine-oil level before and after the engine is first started; refer to [Checking the Engine-oil Level \(page 19\)](#).
2. Check the transaxle/hydraulic-fluid level before the engine is first started; refer to [Checking the Transaxle/Hydraulic-fluid Level \(page 21\)](#).
3. Check the brake-fluid level before the engine is first started; refer to [Checking the Brake-fluid Level \(page 23\)](#).

# Product Overview

## Controls

**Note:** Determine the left and right sides of the machine from the normal operating position.

### Accelerator Pedal

The accelerator pedal (Figure 5) gives the operator the ability to vary the engine and ground speed of the machine when the transmission is in gear. Pressing the pedal increases the engine rpm and ground speed. Releasing the pedal decreases the engine rpm and ground speed of the machine.

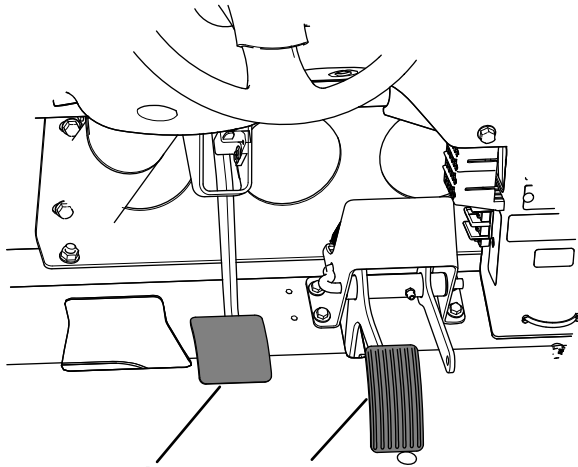

Figure 5

1. Brake pedal
2. Accelerator pedal

### Clutch Pedal

The clutch pedal (Figure 5) must be fully pressed to disengage clutch when starting the engine or shifting transmission gears. Release the pedal smoothly when the transmission is in gear to prevent unnecessary wear on the transmission and other related parts.

**Important:** Do not ride the clutch pedal during operation. The clutch pedal must be fully out or the clutch will slip causing heat and wear. Never hold the vehicle stopped on a hill using the clutch pedal. Damage to the clutch may occur.

### Brake Pedal

The brake pedal (Figure 5) is used to apply service brakes to stop or slow vehicle.

#### ⚠ CAUTION

Worn or maladjusted brakes may result in personal injury. If the brake pedal travels to within 3.8 cm (1-1/2 inches) of the vehicle floor board, the brakes must be adjusted or repaired.

## Gear-shift Lever

Fully press the clutch pedal and move the shift lever (Figure 6) into the desired gear selection. A diagram of the shift pattern is shown below.

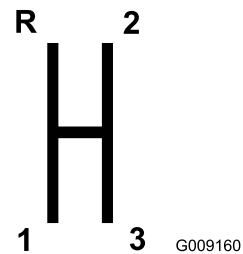

Figure 6

**Important:** Do not shift the transaxle to the reverse or forward gear unless the vehicle is standing still. Damage to the transaxle may occur.

#### ⚠ CAUTION

Down shifting from too high a speed can cause the rear wheels to skid resulting in loss of machine control as well as clutch and/or transmission damage. Shift smoothly to avoid grinding gears.

### Differential Lock

The differential lock allows rear axle to be locked for increased traction. The differential lock (Figure 7) may be engaged when the machine is in motion. Move the lever forward and to the right to engage the lock.

**Note:** Machine motion plus a slight turn is required to engage or disengage differential lock.

#### ⚠ CAUTION

Turning with the differential lock on can result in loss of machine control. Do not operate with differential lock on when making sharp turns or at high speeds; refer to [Using the Differential Lock \(page 28\)](#).

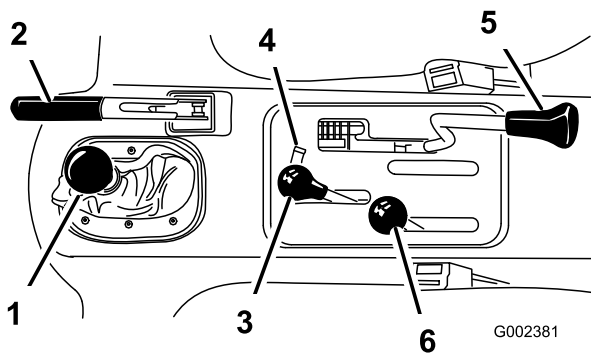

Figure 7

- |                       |                           |
|-----------------------|---------------------------|
| 1. Gear shift lever   | 4. Hydraulic lift lock    |
| 2. Parking brake      | 5. Differential lock      |
| 3. Hydraulic bed lift | 6. High–low range shifter |

## Parking Brake

Whenever the engine is shut off, set the parking brake (Figure 7) in order to prevent the machine from accidentally moving.

- To set the parking brake, pull back on the lever.
- To release, push the lever forward.

**Note:** Release the parking brake before moving the machine.

If you park the machine on a steep grade, set the parking brake, shift the transmission into first gear on a uphill grade or reverse gear on a down hill grade, and place chocks at the down hill side of the wheels.

## Hydraulic Lift

The hydraulic lift raises and lowers the bed. Move it rearward to raise the bed, and forward to lower it (Figure 7).

**Important:** When lowering the bed, hold the lever in the forward position for 1 or 2 seconds after the bed contacts the frame to secure it in the lowered position. Do not hold the hydraulic lift in either the raise or lower position, for more than 5 seconds, once the cylinders have reached the end of their travel.

## Hydraulic-lift Lock

The hydraulic-lift lock locks the lift lever, so the hydraulic cylinders do not operate when the machine is not equipped with a bed (Figure 7). It also locks the lift lever in the On position when using the hydraulics for attachments.

## High–Low Range Shifter

The high–low range shifter adds 3 additional speeds for precise speed control (Figure 7):

- The machine must be completely stopped before shifting between the High and Low range.
- Shift only on level ground.

- Press the clutch pedal fully.
- Move the lever fully forward for High and fully rearward for Low.

High is for higher speed driving on level, dry surfaces with light loads.

Low is for low-speed driving. Use this range when greater than normal power or control is required. For example, steep grades, difficult terrain, heavy loads, slow speed but high-engine speed (spraying).

**Important:** There is a location between High and Low in which the transaxle is in neither range. Do not use this position as a neutral position because the vehicle could move unexpectedly if the High–Low shifter is bumped and the gear-shift lever is in gear.

## Starter Switch

The starter switch is located to the right of the steering column and below the indicator lights for the battery, engine oil pressure, engine coolant temperature, glow plugs (Figure 8). Use the starter switch to start and stop the engine. The switch has 3 positions: Off, On, and Start. Rotate the key clockwise to the On position to activate the glow plugs. When the glow plug indicator light turns off, rotate the key counterclockwise to the Start position to start the engine. To shut off the engine, rotate the key counterclockwise to the Off position.

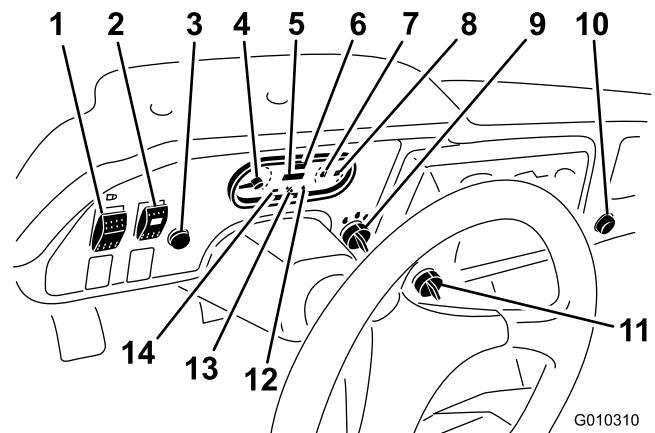

Figure 8

- |   |                                |
|---|--------------------------------|
| 1. Light switch                                 | 8. Fuel gauge                  |
| 2. High-flow-hydraulics switch (TC models only) | 9. Ignition switch             |
| 3. Horn (TC models only)                        | 10. Power point                |
| 4. Tachometer                                   | 11. 3rd high lockout switch    |
| 5. Hour meter                                   | 12. Oil pressure warning light |
| 6. Speedometer                                  | 13. Glow-plug indicator        |
| 7. Coolant-temperature gauge and light          | 14. Charge indicator           |

**Note:** Remove the key from the starter when leaving the machine.

## Hour Meter

Indicates the total hours of machine operation. The hour meter (Figure 8) starts to function whenever the key switch is rotated to the On position or if the engine is running.

## 3rd High Lockout Switch

Move the 3rd-high-lockout switch (Figure 8) to the slow position and remove the key to prevent the use of third gear when in the High range. The engine will shut off if the shift lever is moved to third gear when in High range. The key is removable in either position.

## Light Switch

Push the light switch (Figure 8) to toggle the headlights on or off.

## Oil Pressure Warning Light

The oil pressure warning light glows (Figure 8) if the engine-oil pressure drops below a safe level while the engine is running. If the light flickers or remains on, stop the vehicle, turn off the engine, and check the oil level. If the oil level is low, but adding oil does not cause the light to go out when the engine is restarted, turn the engine off immediately and contact your local Toro distributor for assistance.

Check the operation of warning lights as follows:

1. Apply the parking brake.
2. Turn the starter key to the On/Preheat position, but do not start the engine.

**Note:** The oil pressure light should glow red. If the light does not function, either a bulb is burned out or there is a malfunction in the system which must be repaired.

**Note:** If engine was just turned off, it may take 1 to 2 minutes for the light to come on.

## Glow-plug Indicator

The glow-plug indicator (Figure 8) will glow red when the glow plugs are activated.

**Important:** The glow plug indicator will turn on, for an additional 15 seconds, when the switch returns to the Start position.

## Coolant-temperature Gauge and Light

Registers the coolant temperature of the engine. Operates only when the starter switch is in On position (Figure 8). The indicator light will illuminate blinking red if the engine overheats.

## Charge Indicator

Illuminates when battery is being discharged. If the light illuminates during operation, stop the machine, turn off the

engine, and check for possible causes, such as the alternator belt (Figure 8).

**Important:** If the alternator belt is loose or broken, do not operate the machine until adjustment or repair is complete. Failure to observe this precaution may result in damage to the engine.

Check the operation of warning lights as follows:

- Apply the parking brake.
- Turn the starter key to the On/Preheat position, but do not start the engine. The coolant temperature, charge indicator, and oil-pressure lights should glow. If any light does not function, either a bulb is burned out or there is a malfunction in the system which must be repaired.

## Fuel Gauge

The fuel gauge shows the amount of fuel in the tank. It operates only when starter switch is in the On/Preheat position (Figure 8). Red indicates low fuel level and blinking red indicates near empty.

## High-flow Hydraulics Switch (TC models only)

Turn on the switch to activate the high-flow hydraulics (Figure 8).

## Horn Button (TC models only)

Pressing the horn button activates the horn (Figure 8).

## Tachometer

The tachometer registers the speed of the engine (Figure 8 and Figure 9). White triangle indicates the desired rpm for PTO operation (Figure 9).

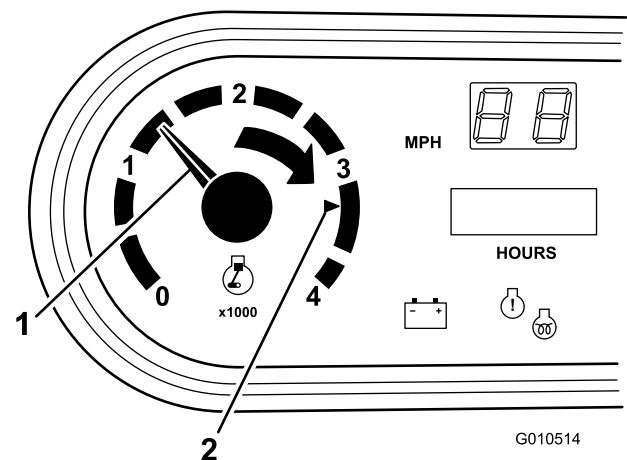

Figure 9

1. Speed of the engine
2. 3,300 rpm for 540 rpm PTO operation



## Speedometer

Registers the ground speed of the machine (Figure 8). The speedometer is in mph but can easily be converted to km/h; refer to [Converting the Speedometer](#) (page 51).

## Power Point

Use the power point (Figure 8) to power optional 12 volt electrical accessories.

## Passenger Hand Hold

The passenger hand hold is located on the dashboard (Figure 10).

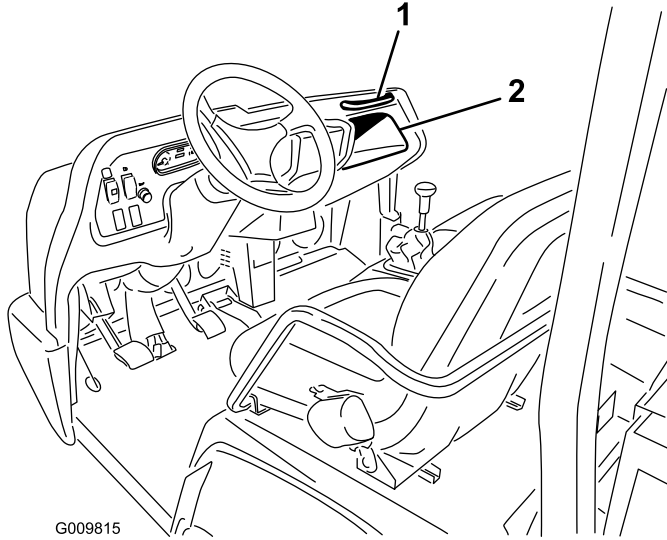
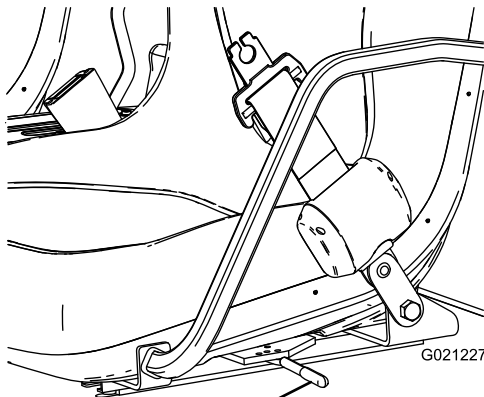

**Figure 10**

1. Passenger hand hold      2. Storage compartment

## Seat-adjusting Lever

The seats can be adjusted before and after for operator comfort (Figure 11).



**Figure 11**

1. Seat-adjusting lever

## Specifications

**Note:** Specifications and design are subject to change without notice.

### Dimensions

Overall Width	160 cm (63 inches)
Overall Length	Without bed: 326 cm (128 inches) With full bed: 331 cm (130 inches) With 2/3 bed in rear-mounting location: 346 cm (136 inches)
Base Weight (Dry)	Model 07385—887 kg (1956 lb) Model 07385H—887 kg (1956 lb) Model 07385TC—924kg (2037 lb) Model 07387—914 kg (2015 lb) Model 07387H—914 kg (2015 lb) Model 07387TC—951 kg (2096 lb)
Rated Capacity (includes 91 kg (200 lb) operator, 91 kg (200 lb) passenger and loaded attachment).	Model 07385—1471 kg (3244 lb) Model 07385TC—1435 kg (3163 lb) Model 07387—1445 kg (3185 lb) Model 07387TC—1408 kg (3104 lb)
Maximum. Gross Vehicle Weight	2359 kg (5200 lb)
Tow Capacity	Tongue weight: 272 kg (600 lb) Maximum trailer weight: 1587 kg (3500 lb)
Ground Clearance	18 cm (7 inches) with no load
Wheel Base	118 cm (70 inches)
Wheel Tread (center line to center line)	Front: 117 cm (46 inches) Rear: 121 cm (48 inches)
Height	191 cm (75 inches) to top of ROPS

## Attachments/Accessories

A selection of Toro approved attachments and accessories is available for use with the machine to enhance and expand its capabilities. Contact your Authorized Service Dealer or Distributor or go to [www.Toro.com](http://www.Toro.com) for a list of all approved attachments and accessories.

# Operation

**Note:** Determine the left and right sides of the machine from the normal operating position.

## ⚠ CAUTION

Before servicing or making adjustments to the machine, stop the engine, set the parking brake, and remove the key from the switch. Remove any load material from the bed or other attachment before working under a raised bed. Never work under a raised bed without positioning the safety support on a fully extended cylinder rod.

## Operating the Cargo Box

**Note:** Center loads in the cargo box if possible.

**Note:** Remove all cargo from the box before lifting the box up to service the machine.

### Raising the Cargo Box

## ⚠ WARNING

Driving the machine with the cargo box raised may cause the machine to tip or roll easier. The box structure may become damaged if you operate the machine with the box raised.

- Only operate the machine when the cargo box is down.
- After emptying the cargo box, lower it.

## ⚠ CAUTION

If a load is concentrated near the back of the cargo box when you release the latches, the box may unexpectedly tip open injuring you or bystanders.

- Center loads in the cargo box if possible.
- Hold the cargo box down and ensure that no one is leaning over the box or standing behind it when releasing the latches.
- Remove all cargo from the box before lifting the box up to service the machine.

Move the lever backward to raise the cargo box (Figure 12).

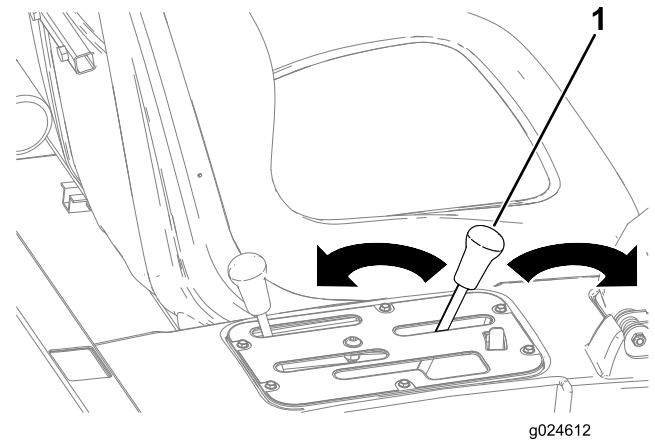

Figure 12

1. Cargo box lever

### Lowering the Box

## ⚠ WARNING

The weight of the box may be heavy. Hands or other body parts could be crushed.

Keep hands and other body parts clear when lowering the box.

Move the lever forward to lower the cargo box (Figure 12).

### Opening the Tailgate

1. Ensure that the cargo box is lowered completely.
2. Open the latches on the left and right side of the cargo box and lower the tailgate (Figure 13).

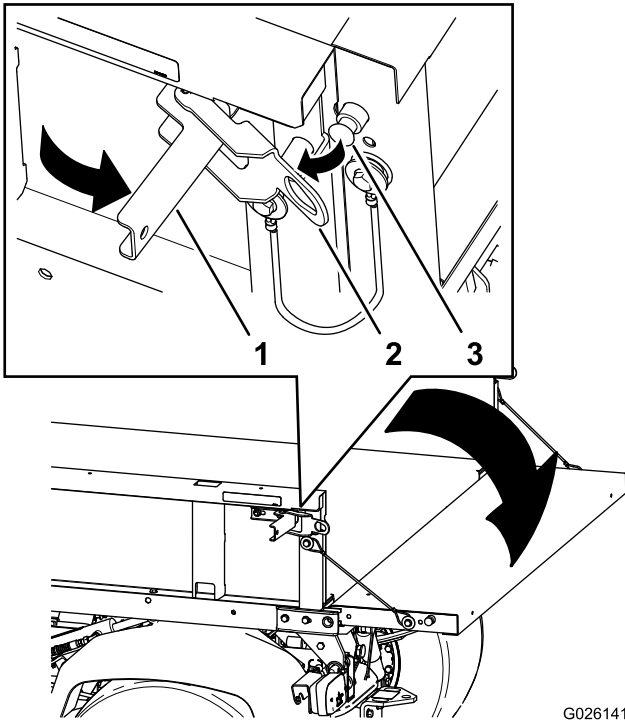

Figure 13

- 1. Latch handle
- 2. Latch gate
- 3. Latch pin

engine has already ran, allow the oil to drain back down to the sump for at least 10 minutes before checking. If the oil level is at or below the Add mark on the dipstick, add oil to bring the oil level to the Full mark. **Do not overfill the engine with oil.** If the oil level is between the Full and Add marks, no additional oil is required.

1. Position the machine on a level surface.
2. Remove the dipstick and wipe it with a clean rag (Figure 15).

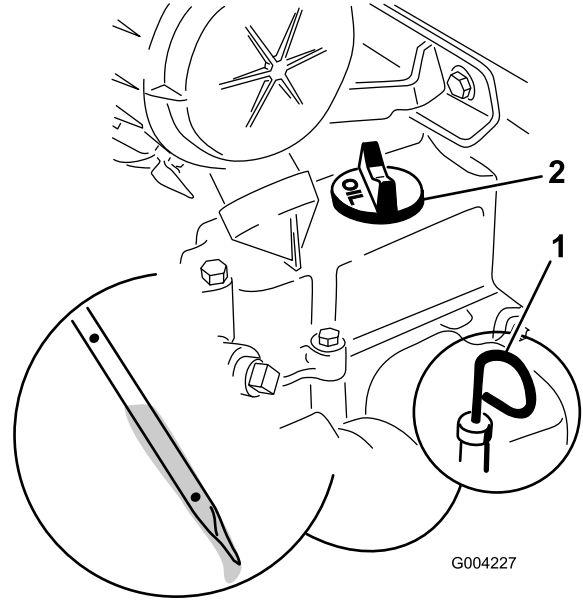

Figure 15

1. Dipstick
2. Oil-fill cap

## Checking the Engine-oil Level

**Service Interval:** Before each use or daily

**Engine oil type:** Detergent diesel engine oil API CH-4 or higher

**Engine-oil viscosity:** Choose an engine-oil viscosity according to the ambient-air temperature to the table in Figure 14.

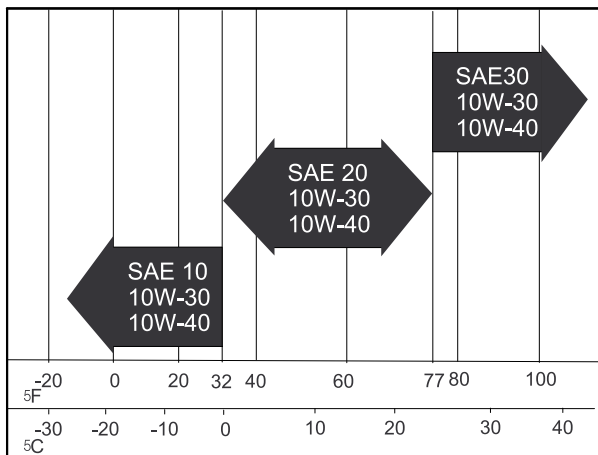

Figure 14

3. Insert the dipstick into the tube and make sure that it is seated fully (Figure 15).
4. Remove dipstick and check the level of the oil (Figure 15).
5. If the oil level is low, remove the oil-fill cap (Figure 15), and add enough oil to raise the level to the Full mark on the dipstick.
6. Install the dipstick firmly in place (Figure 15).

**Note:** The best time to check the engine oil is when the engine is cool before it has been started for the day. If the

# Adding Fuel

**Fuel tank capacity:** 22 L (5.85 US gallons).

Use only clean, fresh diesel fuel or biodiesel fuels with low (<500 ppm) or ultra low (<15 ppm) sulfur content. The minimum cetane rating should be 40. Purchase fuel in quantities that can be used within 180 days to ensure fuel freshness.

- Use summer grade diesel fuel (No. 2-D) at temperatures above -7° C (20° F) and winter grade (No. 1-D or No. 1-D/2-D blend) below that temperature.
- Use of winter grade fuel at lower temperatures provides lower flash point and cold flow characteristics which will ease starting and reduce fuel filter plugging.

**Note:** Use of summer grade fuel above -7° C (20° F) will contribute toward longer fuel pump life and increased power compared to winter grade fuel.

**Important:** Do not use kerosene or gasoline instead of diesel fuel. Failure to observe this caution will damage the engine.

## ⚠ WARNING

Fuel is harmful or fatal if swallowed. Long-term exposure to vapors can cause serious injury and illness.

- Avoid prolonged breathing of vapors.
- Keep your face away from the nozzle and gas tank or conditioner opening.
- Keep fuel away from your eyes and skin.

## ⚠ DANGER

Under certain conditions, diesel fuel and fuel vapors are highly flammable and explosive. A fire or explosion from fuel can burn you and others and can cause property damage.

- Before removing the fuel tank cap, make sure the vehicle is positioned on a level surface. Open fuel tank cap slowly.
- Use a funnel and fill the fuel tank outdoors, in an open area, when the engine is off and is cold. Wipe up any fuel that spills.
- Do not fill the fuel tank completely full. Add fuel to the fuel tank until the level is 25 mm (1 inch) below the bottom of the filler neck. This empty space in the tank allows the fuel to expand.
- Never smoke when handling fuel, and stay away from an open flame or where fuel fumes may be ignited by a spark.
- Store fuel in a clean, safety-approved container and keep the cap in place.

# Using Biodiesel Fuel

This machine can also use a biodiesel blended fuel of up to B20 (20% biodiesel, 80% petrodiesel). The petrodiesel portion should be low or ultra low sulfur. Observe the following precautions:

- The biodiesel portion of the fuel must meet specification ASTM D6751 or EN14214.
  - The blended fuel composition should meet ASTM D975 or EN590.
  - Painted surfaces may be damaged by biodiesel blends.
  - Use B5 (biodiesel content of 5%) or lesser blends in cold weather.
  - Monitor seals, hoses, gaskets in contact with fuel as they may be degraded over time.
  - Fuel filter plugging may be expected for a time after converting to biodiesel blends.
  - Contact your distributor if you wish for more information on biodiesel.
1. Clean the area around the fuel-tank cap.
  2. Remove the fuel-tank cap (Figure 16).

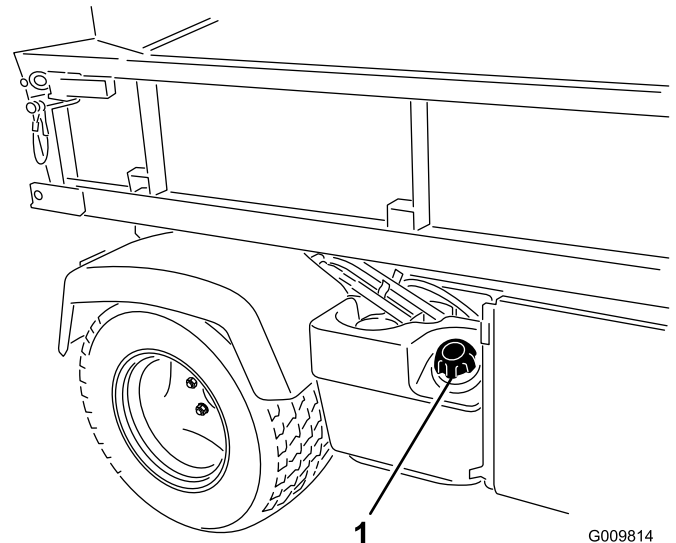

**Figure 16**

1. Fuel-tank cap

3. Fill the tank slightly below the top of the tank, (bottom of the filler neck), then install the cap.

**Note:** Do not overfill the fuel tank with fuel.

4. Wipe up any fuel that may have spilled to prevent a fire hazard.

# Checking the Coolant Level

**Service Interval:** Before each use or daily

**Cooling system capacity:** 3.7 L (4 US qt)

**Coolant type:** a 50/50 solution of water and permanent ethylene-glycol antifreeze.

## ⚠ CAUTION

If the engine has been running, the pressurized, hot coolant can escape and cause burns.

- Do not open the radiator cap.
- Allow the engine to cool at least 15 minutes or until the radiator cap is cool enough to touch without burning your hand.
- Use a rag when opening the reserve tank cap, and open the cap slowly to allow steam to escape.
- Do not check the coolant level at the radiator; only check the coolant level at the reserve tank.

1. Park the machine on a level surface.
2. Check the coolant level inside the reserve tank (Figure 17).

**Note:** The coolant should be up to the bottom of the filler neck when the engine is cold.

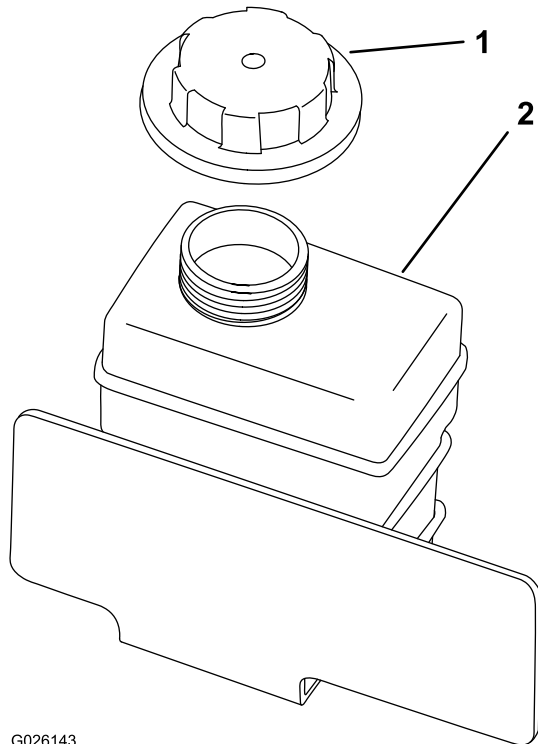

**Figure 17**

1. Reserve tank-cap
2. Reserve tank

3. If coolant is low, remove the reserve tank cap and add a 50/50 mixture of water and permanent ethylene-glycol antifreeze.

**Note:** Do not overfill the reserve tank with coolant.

4. Install the reserve-tank cap.

# Checking the Transaxle/Hydraulic-fluid Level

**Service Interval:** Before each use or daily (check the fluid level before the engine is first started and every 8 hours or daily, thereafter.)

**Transaxle fluid type:** Dexron III ATF

1. Position the machine on a level surface.
2. Clean the area around the dipstick (Figure 18).

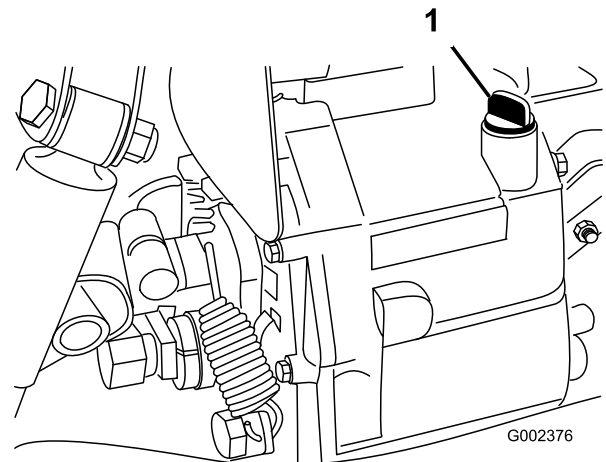

**Figure 18**

1. Dipstick

3. Unscrew the dipstick from the top of the transaxle and wipe it with a clean rag.
4. Screw the dipstick into the transaxle and ensure that it is fully seated.
5. Unscrew the dipstick and check the fluid level.

**Note:** The fluid should be up to top of the flat portion of the dipstick.

6. If the level is low, add enough of the specified fluid to achieve the proper level.

# Checking the High Flow Hydraulic-fluid Level (TC models only)

**Service Interval:** Before each use or daily (check the level of hydraulic fluid before the engine is first started, and daily thereafter)

**Hydraulic-fluid type:** Toro Premium All Season Hydraulic Fluid (Available in 5 gallon pails or 55 gallon drums. See parts catalog or Toro distributor for part numbers.)

**Alternate fluids:** If the Toro fluid is not available, another conventional petroleum-based fluid may be used provided it meets the following material properties and industry specifications. Consult with your lubricant distributor to identify a satisfactory product.

**Note:** Toro will not assume responsibility for damage caused by improper substitutions, so use only products from reputable manufacturers who will stand behind their recommendation.

**High Viscosity Index/Low Pour Point Antiwear Hydraulic Fluid, ISO VG 46**

## Material Properties:

- Viscosity—ASTM D445 cSt @ 40°C: 44 to 48/cSt @ 100°C: 7.9 to 8.5
- Viscosity Index, ASTM D2270—140 to 152
- Pour Point, ASTM D97— -35°F to -46°F
- FZG, Fail stage—11 or better
- Water content (new fluid)—500 ppm (maximum)

## Industry Specifications:

Vickers I-286-S, Vickers M-2950-S, Denison HF-0, Vickers 35 VQ 25 (Eaton ATS373-C)

1. Clean the area around the filler neck and the cap of the hydraulic tank (Figure 19).
2. Remove the cap from the filler neck.

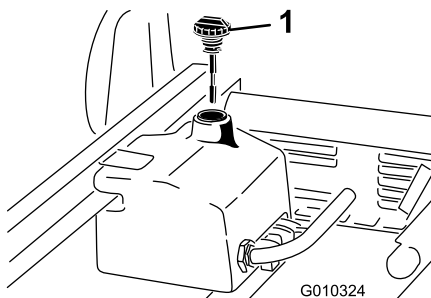

**Figure 19**

1. Cap

4. Insert the dipstick into the filler neck, then remove it and check the fluid level.

**Note:** The fluid level should be between the 2 marks on the dipstick.

5. If the level is low, add the appropriate fluid to raise the level to the upper mark; refer to [Changing the High-flow Hydraulic fluid and Filter \(TC models only\) \(page 53\)](#).
6. Install the dipstick and cap onto the filler neck.
7. Start the engine and turn on the attachment.

**Note:** Let them run for about 2 minutes to purge air from the system.

**Important:** The machine must be running before starting the high-flow hydraulics.

8. Stop the engine and attachment and check for leaks.

## ▲ WARNING

**Hydraulic fluid escaping under pressure can penetrate skin and cause injury.**

- Make sure all hydraulic fluid hoses and lines are in good condition and all hydraulic connections and fittings are tight before applying pressure to the hydraulic system.
- Keep your body and hands away from pin hole leaks or nozzles that eject high pressure hydraulic fluid.
- Use cardboard or paper to find hydraulic leaks.
- Safely relieve all pressure in the hydraulic system before performing any work on the hydraulic system.
- Seek immediate medical attention if fluid is injected into your skin.

# Checking the Front-differential-oil Level (4-wheel drive models only)

**Service Interval:** Every 100 hours/Monthly (whichever comes first)

**Differential-oil type:** Mobil 424 hydraulic oil

1. Position the machine on a level surface.
2. Clean the area around the fill/check plug on side of the differential (Figure 20).

3. Remove the dipstick (Figure 19) from the filler neck and wipe it with a clean rag.



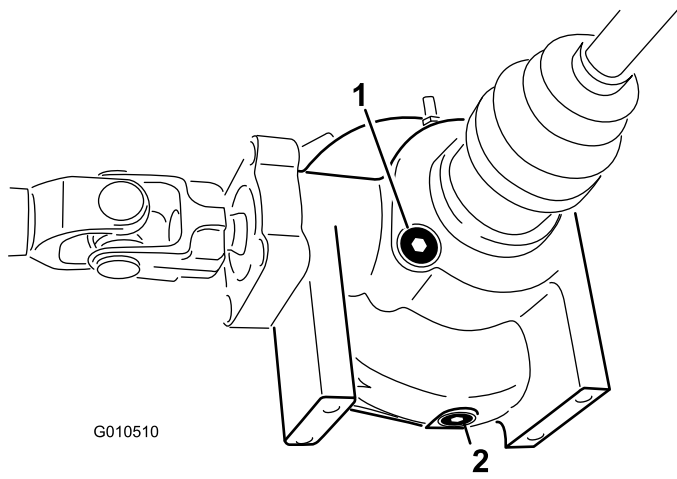

**Figure 20**

1. Fill/check plug
2. Drain plug

3. Remove the fill/check plug and check the level of the oil.

**Note:** The oil should be up to hole.

4. If the oil is low, add specified oil.
5. Install the fill/check plug.

## Checking the Torque of the Wheel Nuts

**Service Interval:** After the first 2 hours

After the first 10 hours

Every 200 hours

### **▲ WARNING**

Failure to maintain proper torque of the wheel nuts could result in failure or loss of a wheel and may result in personal injury.

Torque the front and rear wheel nuts to 109 to 122 N-m (80 to 90 ft-lb) after 1 to 4 hours of operation and again after 10 hours of operation. Torque every 200 hours thereafter.

## Checking the Tire Pressure

**Service Interval:** Before each use or daily

The air pressure in the front tires is 220 kPa (32 psi) and the rear tires is 124 kPa (18 psi).

Check the tire pressure frequently to ensure proper inflation. If the tires are not inflated to the correct pressure, the tires will wear prematurely.

Figure 21 is an example of tire wear caused by under inflation.

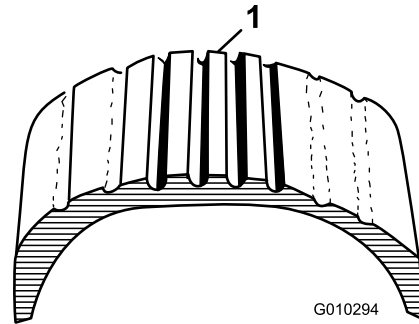

**Figure 21**

1. Under-inflated tire

Figure 22 is an example of tire wear caused by over inflation.

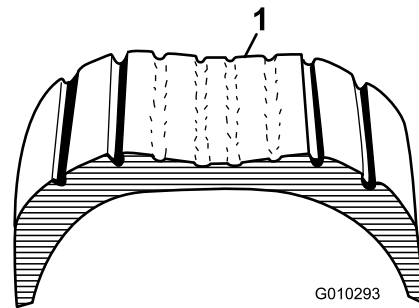

**Figure 22**

1. Over-inflated tire

## Checking the Brake-fluid Level

**Service Interval:** Before each use or daily—Check the brake-fluid level. (Check the level before the engine is first started and every 8 hours or daily, thereafter.)

Every 1,000 hours/Every 2 years (whichever comes first)—Change the brake fluid.

**Brake fluid type:** DOT 3 brake fluid

The brake-fluid reservoir is located under the dash.

1. Park the machine on a level surface.
2. The fluid level should be up to the Full line on the reservoir (Figure 23).

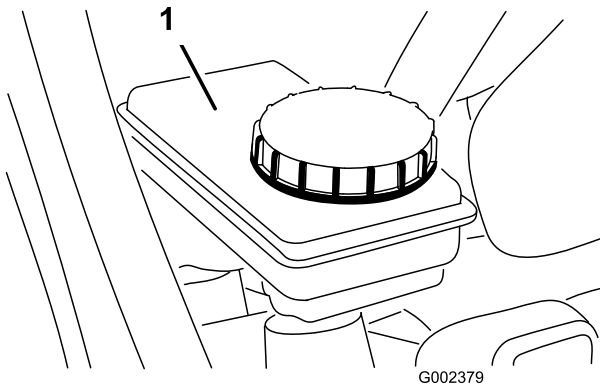

**Figure 23**

1. Brake-fluid reservoir

3. If the fluid level is low, clean the area around the cap, remove the reservoir cap, and fill the reservoir to the proper level with the specified brake fluid.

**Note:** Do not overfill the reservoir with brake fluid.

**Note:** You can remove the hood access to the reservoir from the front of the machine (Figure 24).

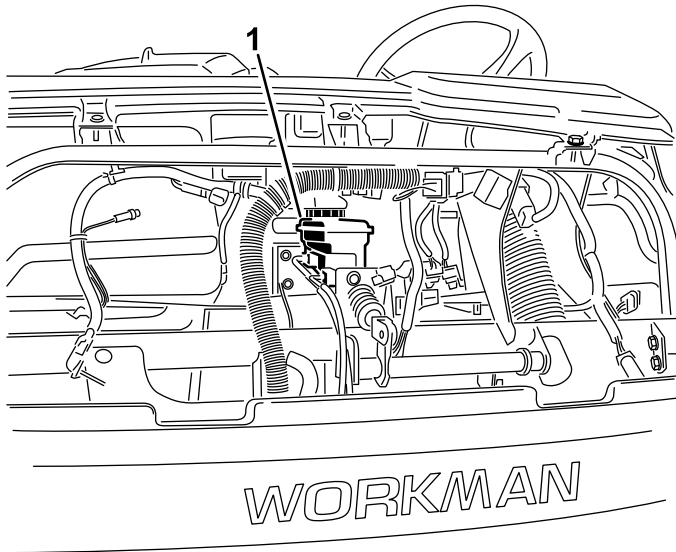

**Figure 24**

1. Brake-fluid reservoir

## Starting the Engine

1. Sit on the operator's seat and engage the parking brake.
2. Disengage the PTO and high flow hydraulics (if so equipped) and move the hand throttle lever to the Off position (if so equipped).
3. Move the shift lever to the Neutral position and press the clutch pedal.
4. Ensure that the hydraulic-lift lever is in the center position.

5. Keep your foot off of the accelerator pedal.
6. Turn the starter switch to the On position. When the glow plug indicator light goes off, the engine is ready to start.
7. Rotate the starter key switch to the Start position. Release the key immediately when the engine starts and allow it to return to the Run position.

**Note:** The glow plug indicator will turn on for an additional 15 seconds, when the switch returns to the Run position.

**Note:** Do not run the starter motor more than 10 seconds at a time or premature starter failure may result. If engine fails to start after 10 seconds, turn the key to the Off position. Check the controls and starting procedure, wait 10 additional seconds, and repeat the starting operation.

## Driving the Vehicle

1. Release the parking brake.
2. Fully press the clutch pedal.
3. Move the gear shift lever to first gear.
4. Release the clutch pedal smoothly while pressing the accelerator pedal.
5. When the machine gains enough speed, remove your foot from the accelerator pedal, fully press the clutch pedal, move the gear shift lever to the next gear and release the clutch pedal while pressing the accelerator pedal.
6. Repeat the procedure until the desired speed is attained.

**Important:** Always stop the machine before shifting to reverse a forward gear or to a forward gear from reverse.

**Note:** Avoid long periods of engine idling.

Use the chart below to determine the ground speed of the vehicle at 3600 rpm.

Gear	Range	Ratio	Speed (kmh)	Speed (mph)
1	L	82.83 : 1	4.7	2.9
2	L	54.52 : 1	7.2	4.5
3	L	31.56 : 1	12.5	7.7
1	H	32.31 : 1	12.2	7.6
2	H	21.27 : 1	18.5	11.5
3	H	12.31 : 1	31.9	19.8
R	L	86.94 : 1	4.5	2.8
R	H	33.91 : 1	11.6	7.1

**Important:** Do not attempt to push or tow the machine to get it started. Damage to the drive train could result.



## Stopping the Machine

To stop the machine, remove your foot from the accelerator pedal, press the clutch pedal, then press the brake pedal.

## Stopping the Engine

To stop the engine, rotate the starter key to the Off position and engage the parking brake. Remove the key from the switch to prevent accidental starting.

## Breaking in a New Machine

To provide proper performance and long machine life, follow these guidelines for the first 100 operating hours.

- Check the fluid and engine oil levels regularly and be alert for indications of overheating in any component of the machine.
- After starting a cold engine, let it warm up for about 15 seconds before shifting into gear.
- Avoid racing the engine.
- To ensure optimum performance of the brake system, burnish (break-in) the brakes before use. To burnish the brakes, bring the vehicle up to full speed, apply the brakes to rapidly stop the vehicle without locking up the tires. Repeat this 10 times, waiting 1 minute between stops to avoid overheating the brakes. This is most effective if the machine is loaded with 454 kg (1000 lb).
- Vary the machine speed during operation. Avoid excessive idling. Avoid fast starts and quick stops.
- A break-in oil for the engine is not required. The original engine oil is the same type specified for regular oil changes.
- Refer to the Maintenance section for any special low hour checks.

## Checking the Safety-interlock System

**Service Interval:** Before each use or daily

The purpose of the safety-interlock system is to prevent the engine from cranking or starting unless the clutch pedal is pressed.

### ⚠ CAUTION

**If the safety-interlock switches are disconnected or damaged the machine could operate unexpectedly causing personal injury.**

- **Do not tamper with the interlock switches.**
- **Check the operation of the interlock switches daily and replace any damaged switches before operating the machine.**

**Note:** Refer to *Attachment Operator's Manual* for procedures on checking the attachment interlock system.

## Verifying the Clutch Interlock Switch

1. Sit on the operator's seat and engage the parking brake.
2. Move the shift lever to the Neutral position.

**Note:** The engine will not crank if the hydraulic-lift lever is locked in the forward position.

3. Without pressing the clutch pedal, rotate the key clockwise to the Start position.

**Note:** If the engine cranks or starts, there is a malfunction in the interlock system that must be repaired before operating the machine.

## Verifying the Hydraulic-lift Lever Interlock Switch

1. Sit on the operator's seat and engage the parking brake.
2. Move the shift lever to the Neutral position and ensure that the hydraulic-lift lever is in the center position.
3. Press clutch pedal.
4. Move the hydraulic-lift lever forward and rotate the start key clockwise to the start position.

**Note:** If engine cranks or starts, there is a malfunction in the interlock system that must be repaired before operating the machine.

## Ensuring Passenger Safety

Whenever you have a passenger riding in the machine, make sure he or she is wearing the seat belt and holding on securely. Drive slower and turn less sharply because your passenger does not know what you are going to do next and may not be prepared for turning, stopping, accelerating, and bumps.

You and your passenger should remain seated at all times, keeping arms and legs inside the vehicle. The operator should keep both hands on steering wheel, whenever possible, and the passenger should use the hand holds provided (Figure 25 and Figure 26).

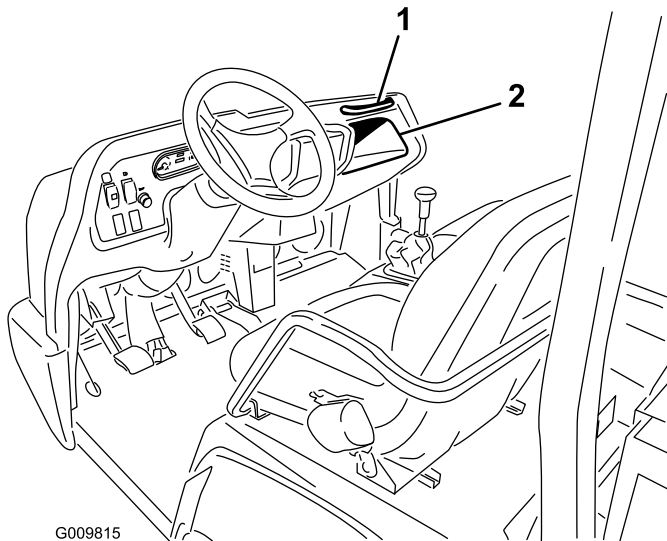

Figure 25

1. Passenger-hand hold
2. Storage compartment

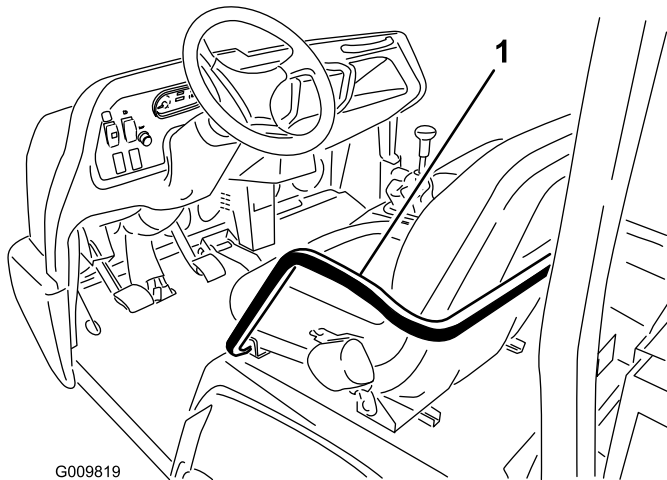

Figure 26

1. Hand hold and hip restraint

Never allow passengers in the dump box or on any attachments. The vehicle is meant to have one driver and only one passenger—no more.

## Ensuring Proper Speed

Speed is one of the most important variables leading to accidents. Driving too fast for the conditions can cause you to lose control and have an accident. Speed can also make a minor accident worse. Driving head on into a tree at slow speed can cause injury and damage, but, driving into a tree at high speed can destroy the vehicle and kill you and your passenger.

Never drive too fast for the conditions. If there is any doubt about how fast to drive, slow down.

When using heavy attachments, more than 454 kg (1000 lb), such as sprayers, top dressers, or spreaders, etc., restrict your operating speed by moving the 3rd high lockout switch to the slow position.

## Ensuring Proper Turning

Turning is another important variable leading to accidents. Turning too sharply for the conditions can cause the vehicle to lose traction and skid, or even tip over.

Wet, sandy, and slippery surfaces make turning more difficult and risky. The faster you are going, the worse this situation becomes so, slow down before turning.

During a sharp turn at higher speeds, the inside rear wheel may lift off of the ground. This is not a flaw in the design, it happens with most 4-wheel machine including passenger cars. If this happens, you are turning too sharply for the speed at which you are traveling. **Slow down!**

## Ensuring Proper Braking

It is good practice to slow down before you get near an obstacle. This gives you extra time to stop or turn away. Hitting an obstacle can damage the machine and its contents. More important, it can injure you and your passenger. Gross machine weight has a major impact on your ability to stop and/or turn. Heavier loads and heavier attachments make a vehicle harder to stop or turn. The heavier the load, the longer it takes to stop.

The braking characteristics also change with no bed or attachment on the machine. Fast stops may cause the rear wheels to lock up before the front wheels lock up, which may affect the control of the machine. It is a good idea to decrease machine speed with no bed or attachment.

Turf and pavement are much slipperier when they are wet. It can take 2 to 4 times as long to stop on wet surfaces as on dry surfaces.

If you drive through standing water deep enough to get the brakes wet, they will not work well until they are dry. After driving through water, you should test the brakes to make sure they work properly. If they do not, drive slowly in first gear while putting light pressure on the brake pedal. This will dry the brakes out.

Do not downshift for braking on icy or slippery surfaces (wet grass) or while going down a hill because engine braking may cause skidding and loss of control. Shift to a lower gear before starting down a hill.

## Preventing Tip Overs

The machine is equipped with a roll bar, hip restraints, seat belts, and hand hold. The Rollover Protection System (ROPS) used on the machine will reduce the risk of serious or fatal injury in the unlikely event of a tip over, although the system cannot protect the operator from all possible injuries.

Replace a damaged ROPS, do not repair or revise. Any alteration of the ROPS must be approved by the manufacturer.

The best way to prevent accidents involving utility machine is through continuous supervision and training of operators and paying constant attention to the area in which vehicle is being operated.

The best way for operators to prevent serious injury or death to themselves or others, is to familiarize themselves with the proper operation of the utility vehicle, to stay alert and to avoid actions or conditions which could result in an accident. In the event of a tip over, the risk of serious injury or death will be reduced if the operator is using the ROPS system and seat belts and is following the instructions provided.

## Operating on Hills

### **▲ WARNING**

**Tipping or rolling the machine on a hill could cause serious personal injury.**

- Do not operate the vehicle on steep slopes.
- If engine stalls or you lose headway on a hill, never attempt to turn vehicle around.
- Always back straight down a hill in reverse gear.
- Never back down in neutral or with the clutch depressed, using only the brakes.
- Never drive across a steep hill, always drive straight up or down.
- Avoid turning on a hill.
- Don't "drop the clutch" or slam on the brakes. Sudden speed change can initiate a tip over.

Use extra care when on hills. Never go on hills that are extremely steep. Stopping while going down a hill will take longer than on level ground. Turning while going up or down a hill is more dangerous than turning on the level. Turns while going down hill, especially with the brakes on, and, turning up hill while traversing a hill are particularly dangerous. Even at a slow speed and without a load, tip overs are more likely if you turn on a hill.

Slow down and shift into a lower gear before starting up or down a hill. If you have to turn while on a hill, do it as slowly

and cautiously as possible. Never make sharp or fast turns on a hill.

If you stall or begin to lose headway while climbing a steep hill, quickly apply the brakes, shift to neutral, start the engine and shift to reverse. At idle speed, the engine and transaxle drag will aid the brakes in controlling the vehicle on the hill and help you back down the hill more safely.

Reduce the weight of the load if it is a steep hill or if the load has high center of gravity. Remember, loads can shift, secure them.

**Note:** The machine has excellent hill-climbing ability. The differential lock will increase this ability. Hill climbing traction can also be increased by adding weight to the rear of the vehicle in one of the following ways:

- Adding weight to inside of box, making sure it is secured.
- Mounting wheel weights to rear wheels.
- Adding liquid ballast (calcium chloride) to rear tires.
- Traction will increase with no passenger in front seat.

## Loading and Dumping

The weight and position of the cargo and passenger can change the machine center of gravity and the machine handling. To avoid loss of control resulting in personal injury, follow these guidelines:

Do not carry loads which exceed the load limits described on the machine weight label.

### **▲ WARNING**

**The bed will lower whenever the dump lever is pushed down, even when the engine is off. Turning off the engine will *not* prevent the box from lowering. Always place the safety support on the extended lift cylinder to hold the box up if you are not going to lower it right away.**

The machine has several combinations of boxes, platforms, and attachments available. These can be used in various combinations that allow for maximum capacity and versatility. The full sized box is 140 cm (55 inches) wide by 165 cm (65 inches) long and can hold up to 1360 kg (3000 lb) of evenly distributed cargo.

Loads vary in how they are distributed. Sand spreads out evenly and quite low. Other items, such as bricks, fertilizer or landscape timbers, stack higher in the box.

The height and weight of the load has a significant influence on tip overs. The higher a load is stacked, the more likely the vehicle is to tip over. You may find that 1360 kg (3000 lb) stacks too high for safe operation. Reducing the total weight is one way to reduce the risk of a tip over. Distributing the load as low as possible is another way to reduce the risk of a tip over.

If the load is positioned toward one of the sides, it will make the machine much more likely to tip over on that side. This is especially true when turning if the load is on the outside of the turn.

Never position heavy loads behind the rear axle. If the load is positioned so far to the rear that it is behind the rear axle, it will reduce the weight on the front wheels and this will reduce steering traction. With the load all the way to the back, the front wheels can even come off of the ground when going over bumps or up a hill. This will result in a loss of steering and may lead to the vehicle tipping over.

**As a general rule, position the weight of the load evenly from front to rear and evenly from side to side.**

If a load is not secured, or you are transporting a liquid in a large container such as a sprayer, it can shift. This shifting happens most often while turning, going up or down hills, suddenly changing speeds, or while driving over rough surfaces. Shifting loads can lead to tip overs. Always secure loads so that they do not shift. Never dump the load while the vehicle is sideways on the hill.

Heavy loads increase stopping distance and reduce your ability to turn quickly without tipping over.

The rear cargo space is intended for load carrying purposes only, not for passengers.

## Using the Differential Lock

The differential lock increases the machine traction by locking the rear wheels so one wheel will not spin out. This can help when you have heavy loads to haul on wet turf or slippery areas, going up hills, and on sandy surfaces. It is important to remember, however, that this extra traction is only for temporary limited use. Its use does not replace the safe operation, already discussed concerning steep hills and heavy loads.

The differential lock causes the rear wheels to spin at the same speed. When using differential lock your ability to make sharp turns is somewhat restricted and may scuff the turf. Use the differential lock only when needed, at slower speeds and only in first or second gear.

### **⚠ WARNING**

**Tipping or rolling the machine on a hill will cause serious injury.**

- **The extra traction available with the differential lock can be enough to get you into dangerous situations such as climbing slopes that are too steep to turn around. Be extra careful when operating with the differential lock on, especially on steeper slopes.**
- **If the differential lock is on when making a sharp turn at a higher speed and the inside rear wheel lifts off the ground, there may be a loss of control which could cause vehicle to skid. Use the differential lock only at slower speeds.**

## Using 4-wheel Drive (4-wheel drive models only)

The Automatic on Demand 4-wheel drive feature, on this vehicle does not require operator activation. The front wheel drive is not engaged (no power delivered to front wheels) until the rear wheels begin to lose traction. The bidirectional clutch senses the rear wheels slipping, engages the front wheel drive, and delivers power to the front wheels. The 4 wheel drive system continues to deliver power to the front wheels until the rear wheels have enough traction to move the vehicle without slipping. Once this occurs, the system stops delivering power to the front wheels and the handling characteristics become similar to that of a 2-wheel drive machine. The 4 wheel drive system functions in both forward and reverse, however, when turning the rear wheels will slip slightly more before power is delivered to the front wheels.

### **⚠ WARNING**

**Tipping or rolling the machine on a hill will cause serious injury.**

**The extra traction available with the 4-wheel drive feature can be enough to get you into dangerous situations such as climbing slopes that are too steep to turn around. Be careful when operating, especially on steeper slopes.**

## Transporting the Machine

For moving the machine long distances, use a trailer. Make sure that the machine is secured to the trailer. Refer to [Figure 27](#) and [Figure 28](#) for the location of the tie-down points.

**Important:** Trailers weighing over 680 kg (1500 lb) are required to be equipped with trailer brakes.

**Note:** Load the machine on the trailer with the front of the machine facing forward. If that is not possible, secure the machine hood to the frame with a strap, or remove the hood

and transport and secure it separately or the hood may blow off during transport.

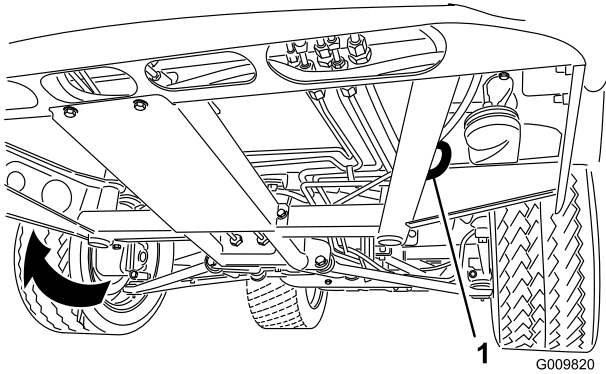

Figure 27

1. Eye hole in frame (each side)

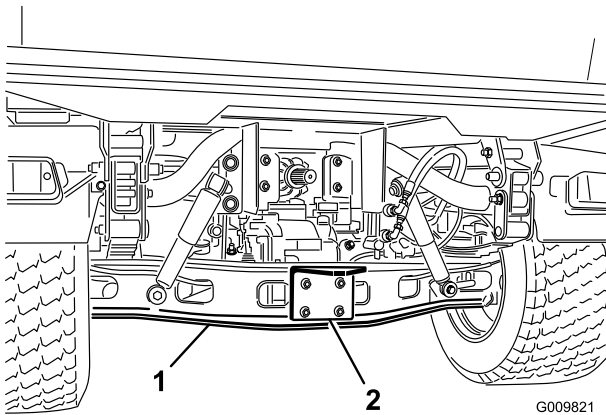

Figure 28

1. Axle
2. Hitch plate

## Towing the Machine

In case of an emergency, the vehicle can be towed for a short distance. However, Toro does not recommend this as a standard procedure.

### **▲ WARNING**

Towing at excessive speeds could cause machine to lose steering control. Never tow the machine at faster than 8 km/h (5 mph).

Towing the machine is a 2-person job. Affix a tow line to holes in the front frame member. Move the shifter to Neutral and release the parking brake. If the machine must be moved a considerable distance, transport it on a truck or trailer.

**Note:** The power steering will not function, making it difficult (increased effort) to steer.

## Towing a Trailer with the Machine

The machine is capable of pulling trailers and attachments of greater weight than the machine itself.

Several types of tow hitches are available for the machine, depending on your application. Contact your Authorized Toro Distributor for details.

When equipped with a tow hitch bolted onto the rear axle tube, your machine can tow trailers or attachments with a Gross Trailer Weight (GTW) up to 1587 kg (3500 lb). Always load a trailer with 60% of the cargo weight in the front of the trailer. This places approximately 10% (272 kg (600 lb) max.) of the Gross Trailer Weight (GTW) on the tow hitch of the machine.

Trailer brakes are required whenever you tow a trailer over 680 kg (1500 lb) GTW is towed behind a machine.

When hauling cargo or towing a trailer (attachment), do not overload your machine or trailer. Overloading can cause poor performance or damage to the brakes, axle, engine, transaxle, steering, suspension, body structure, or tires.

**Important:** To reduce potential for drive line damage, use low range.

When towing fifth-wheel attachments, like a fairway aerator, always install the wheel bar (included with the fifth wheel kit) to prevent the front wheels from lifting off the ground if the towed attachments movement is suddenly impaired.

## Using the Hydraulic Control

The hydraulic control supplies hydraulic power from the machine pump whenever the engine is running. The power can be used through the quick couplers at the rear of the machine.

### **▲ CAUTION**

Hydraulic fluid escaping under pressure can have sufficient force to penetrate skin and do serious damage. Care must be used when connecting or disconnecting hydraulic quick couplers. Stop the engine, apply the parking brake, lower the attachment, and place the remote hydraulic valve in the float detent position to relieve hydraulic pressure before connecting or disconnecting quick couplers.

**Important:** If multiple machines use the same attachment, cross contamination of the transmission fluid may occur. Change the transmission fluid more frequently

## Using the Hydraulic-bed Lift Lever to Control Hydraulic Attachments

- Off Position

This is the normal position for the control valve when it is not being used. In this position the work ports of the control valve are blocked and any load will be held by the check valves in both directions.

- Raise (Quick Coupler “A” Position)

This is the position which will lift the bed, rear hitch attachment or apply pressure to quick coupler A. This also allows hydraulic fluid to return from quick coupler B to flow back into the valve and then out to the reservoir. This is a momentary position and when the lever is released it spring returns to the center Off position.

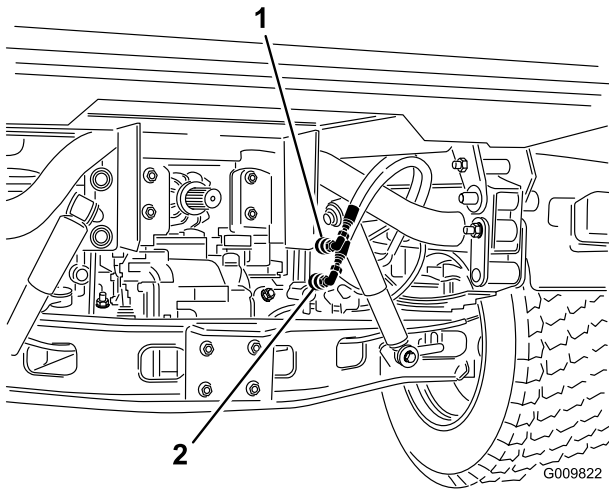

Figure 29

1. Quick coupler A position      2. Quick coupler B position

- Lower (Quick Coupler B Position)

This position will lower the bed, rear hitch attachment, or apply pressure to quick coupler B. This also allows hydraulic fluid to return from quick coupler A to flow back into the valve and then out to the reservoir. This is a momentary position and when the lever is released it spring returns to the center off position. Momentarily holding and then releasing the control lever in this position will provide hydraulic fluid flow to quick coupler B which provides power down on the rear hitch. When released, it will hold the down pressure on the hitch.

**Important:** If used with a hydraulic cylinder, holding the control lever in the lower position causes the hydraulic-fluid flow to go over a relief valve which can damage the hydraulic system.

- On Position

This position is similar to Lower (quick coupler B position). It also directs hydraulic fluid to quick coupler B except that the lever is held in this position by a detent lever in the control panel. This allows hydraulic fluid to flow continuously to equipment that uses a

hydraulic motor. This position must only be used on attachments with a hydraulic motor attached.

**Important:** If used with a hydraulic cylinder or no attachment, the On position causes the hydraulic-fluid flow to go over a relief valve which can damage the hydraulic system. Use this position only momentarily or with a motor attached.

**Important:** Check hydraulic-fluid level after installation of an attachment. Check the operation of the attachment by cycling the attachment several times to purge air from system, then recheck hydraulic-fluid level. The attachment cylinder will slightly affect fluid level in the transaxle. Operation of vehicle with low hydraulic-fluid level can damage the pump, remote hydraulics, power steering, and the vehicle transaxle.

## Connecting the Quick Couplers

**Important:** Clean dirt from quick couplers before connecting. Dirty couplers can introduce contamination into the hydraulic system

1. Pull back the locking ring on the coupler.
2. Insert the hose nipple into the coupler until it snaps into position.

**Note:** When attaching remote equipment to the quick couplers, determine which side requires pressure, then attach that hose to quick coupler B, which will have pressure when the control lever is pushed forward or locked in the On position.

## Disconnecting the Quick Couplers

**Note:** With both the vehicle and attachment turned off, move the lift lever back and forth to remove the system pressure and ease the disconnection of the quick couplers.

1. Pull back the locking ring on the coupler.
2. Pull the hose firmly from the coupler.

**Important:** Clean and install the dust plug and dust covers to the quick coupler ends when not in use.

## Troubleshooting the Hydraulic Control

- Difficulty in connecting or disconnecting quick couplers.  
The pressure not relieved (the quick coupler is under pressure).
- The power steering is turning with great difficulty or it is not turning at all.
  - The hydraulic-fluid level is low.
  - The hydraulic-fluid temperature is hot.
  - The pump is not operating.
- There are hydraulic leaks.
  - The fittings are loose.
  - The fitting is missing the o-ring.
- An attachment does not function.
  - The quick couplers are not fully engaged.
  - The quick couplers are interchanged.
- There is a squealing noise.
  - Remove the valve left in the On detent position causing hydraulic fluid to flow over the relief valve.
  - The belt is loose.
- The engine will not start.  
The hydraulic lever is locked in forward position

# Maintenance

## Recommended Maintenance Schedule(s)

Maintenance Service Interval	Maintenance Procedure
After the first 2 hours	<ul style="list-style-type: none"> <li>• Torque the front and rear wheel nuts.</li> </ul>
After the first 8 hours	<ul style="list-style-type: none"> <li>• Check the condition and tension of the alternator belt.</li> </ul>
After the first 10 hours	<ul style="list-style-type: none"> <li>• Torque the front and rear wheel nuts.</li> <li>• Check the adjustment of the shift cables.</li> <li>• Check the adjustment of the parking brake.</li> <li>• Replace the hydraulic filter.</li> <li>• Change the high-flow hydraulic fluid filter (TC models only).</li> </ul>
After the first 50 hours	<ul style="list-style-type: none"> <li>• Change the engine oil and filter.</li> <li>• Adjust the engine valve clearance.</li> </ul>
Before each use or daily	<ul style="list-style-type: none"> <li>• Check the engine-oil level.</li> <li>• Check the level of the coolant.</li> <li>• Check the transaxle/hydraulic-fluid level. (check the fluid level before the engine is first started and every 8 hours or daily, thereafter.)</li> <li>• Check the high flow hydraulic-fluid level (TC models only). (check the level of hydraulic fluid before the engine is first started, and daily thereafter)</li> <li>• Check the tire pressure.</li> <li>• Check the brake-fluid level. (Check the level before the engine is first started and every 8 hours or daily, thereafter.)</li> <li>• Check the operation of the safety-interlock system.</li> <li>• Check the air filter service indicator.</li> <li>• Drain water or other contaminants from the water separator.</li> <li>• Remove debris from the engine area and radiator (clean more frequently in dirty conditions).</li> </ul>
Every 25 hours	<ul style="list-style-type: none"> <li>• Remove the air cleaner cover, clean out debris, and check the air filter service indicator.</li> </ul>
Every 50 hours	<ul style="list-style-type: none"> <li>• Check the battery-fluid level (every 30 days if in storage).</li> <li>• Check the battery-cable connections.</li> </ul>
Every 100 hours	<ul style="list-style-type: none"> <li>• Check the level of front differential oil (4-wheel drive models only).</li> <li>• Grease all bearings and bushings (lubricate more frequently in heavy duty applications).</li> <li>• Change the engine oil and filter.</li> <li>• Inspect the condition of the tires.</li> </ul>
Every 200 hours	<ul style="list-style-type: none"> <li>• Torque the front and rear wheel nuts.</li> <li>• Inspect the constant-velocity boot for cracks, holes, or a loose clamp.</li> <li>• Check the adjustment of the shift cables.</li> <li>• Check the adjustment of the high-to-low cable.</li> <li>• Check the adjustment of the differential-lock cable.</li> <li>• Check the adjustment of the parking brake.</li> <li>• Check the adjustment of the brake pedal.</li> <li>• Check the condition and tension of the alternator belt.</li> <li>• Check the adjustment of the clutch pedal.</li> <li>• Inspect the service and parking brakes.</li> </ul>
Every 400 hours	<ul style="list-style-type: none"> <li>• Check the fuel lines and connections.</li> <li>• Replace the fuel-filter canister.</li> <li>• Check the front wheel alignment.</li> <li>• Visually inspect the brakes for worn brake shoes.</li> </ul>
Every 600 hours	<ul style="list-style-type: none"> <li>• Change the safety air filter (more frequently in dusty or dirty conditions).</li> <li>• Adjust the engine valve clearance.</li> </ul>



Maintenance Service Interval	Maintenance Procedure
Every 800 hours	<ul style="list-style-type: none"> <li>• Change the front-differential oil.</li> <li>• Change the hydraulic fluid and clean the strainer.</li> <li>• Replace the hydraulic filter.</li> <li>• Change the high-flow hydraulic fluid and filter (TC models only).</li> </ul>
Every 1,000 hours	<ul style="list-style-type: none"> <li>• Change the brake fluid.</li> <li>• Drain/flush the fuel tank.</li> <li>• Flush or replace the coolant-system fluid.</li> </ul>

**Note:** Determine the left and right sides of the machine from the normal operating position.

### **⚠ DANGER**

Only qualified and authorized personnel shall be permitted to maintain, repair, adjust, or inspect the machine.

Avoid fire hazards and have fire protection equipment present in the work area. Do not use an open flame to check level or leakage of fuel, battery electrolyte, or coolant. Do not use open pans of fuel or flammable cleaning fluids for cleaning parts.

### **⚠ CAUTION**

If you leave the key in the starter switch, someone could accidentally start the engine and seriously injure you or other bystanders.

Remove the key from the starter switch before you do any maintenance.

## Operating in Adverse Conditions

**Important:** If the machine is subjected to any of the conditions listed below, maintenance should be performed twice as frequently:

- Desert operation
- Cold climate operation below 0° C (32° F)
- Trailer towing
- Frequent operation on dusty roads
- Construction work
- After extended operation in mud, sand, water, or similar dirty conditions, have your brakes inspected and cleaned as soon as possible. This will prevent any abrasive material from causing excessive wear.

# Premaintenance Procedures

Many of the subjects covered in this maintenance section require raising and lowering the bed. The following precautions must be taken or serious injury or death could result.

## ⚠ WARNING

Before servicing or making adjustments to the machine, stop engine, set parking brake, and remove the key from the starter switch. Remove any load material from the bed or other attachment before working under a raised bed. Never work under a raised bed without positioning the safety support on a fully extended cylinder rod.

## Using the Bed Support

**Important:** Always install or remove the bed support from the outside of the bed.

1. Raise the bed until the lift cylinders are fully extended.
2. Remove the bed support from the storage brackets on back of the ROPS panel (Figure 30).

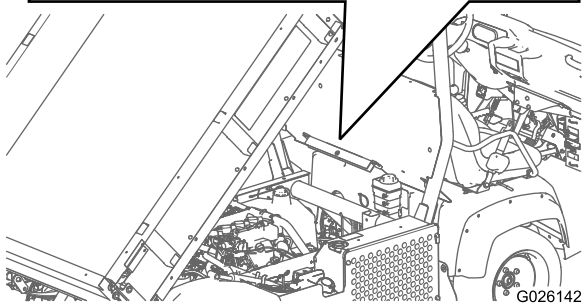
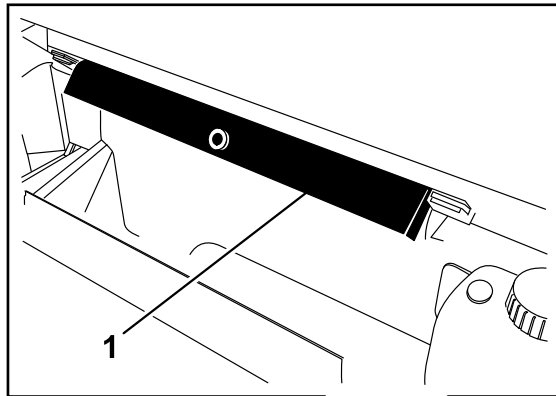

Figure 30

1. Bed support

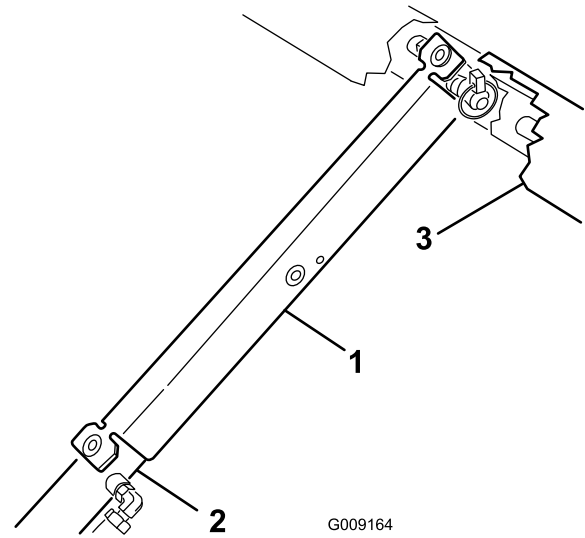

Figure 31

1. Bed support
2. Cylinder barrel
3. Bed

4. Remove the bed support from the cylinder and insert it into the brackets on the back of the ROPS panel.

## ⚠ CAUTION

Do not try to lower bed with bed safety support on cylinder.

3. Push the bed support onto the cylinder rod, making sure that the support end tabs rest on the end of cylinder barrel, and on the cylinder rod end (Figure 31).

## Removing the Full Bed

1. Start the engine, engage the hydraulic-lift lever, and lower the bed until the cylinders are loose in the slots.
2. Release the lift lever and turn off the engine.
3. Remove the lynch pins from the outer ends of the cylinder rod clevis pins (Figure 32).

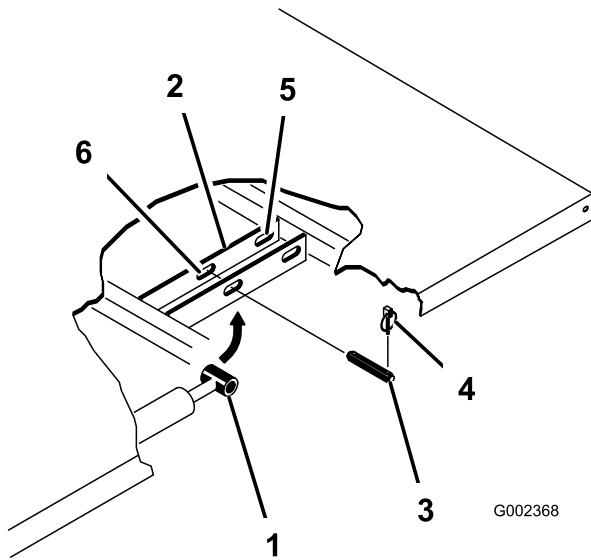

Figure 32

- |                       |                          |
|-----------------------|--------------------------|
| 1. Cylinder rod end   | 4. Lynch pin             |
| 2. Bed-mounting plate | 5. Rear slots (full bed) |
| 3. Clevis pin         | 6. Front slots (2/3 bed) |

4. Remove the clevis pins securing the cylinder rod ends to the bed-mounting plates by pushing the pins towards the inside (Figure 32).
5. Remove the lynch pins and clevis pins securing the pivot brackets to the frame channels (Figure 32).
6. Lift the bed off of the machine.

### ⚠ CAUTION

The full bed weighs approximately 148 kg (325 lb), so do not try to install or remove it by yourself. Use an overhead hoist or get the help of 2 or 3 other people.

7. Store the cylinders in the storage clips.
8. Engage the hydraulic lift-lock lever on the machine to prevent accidental extension of the lift cylinders.

## Installing the Full Bed

**Note:** If the bed sides will be installed on the flat bed, it is easier to install them before installing the bed on the machine.

**Note:** Ensure that the rear pivot plates are bolted to the bed frame/channel so that lower end angles to the rear (Figure 33).

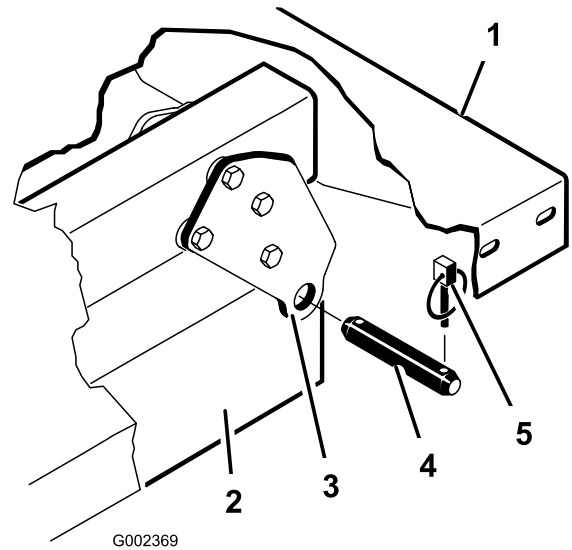

Figure 33

- |                             |               |
|-----------------------------|---------------|
| 1. Left, rear corner of bed | 4. Clevis pin |
| 2. Machine frame channel    | 5. Lynch pin  |
| 3. Pivot plate              |               |

### ⚠ CAUTION

The full bed weighs approximately 148 kg (325 lb), so do not try to install or remove it by yourself. Use an overhead hoist or get the help of 2 or 3 other people.

**Note:** Ensure that the spacer brackets and wear blocks (Figure 34) are installed with the carriage bolt heads positioned inside the machine.

# Raising the Machine

## **⚠ DANGER**

A machine on a jack may be unstable and slip off of the jack, injuring anyone beneath it.

- Do not start the machine while the machine is on a jack.
- Always remove the key from the switch before getting off of the machine.
- Block the tires when the machine is on a jack.
- Do not start the engine while the machine is on a jack, because the engine vibration or wheel movement could cause the machine to slip off of the jack.
- Do not work under the machine without jack stands supporting it. The machine could slip off a jack, injuring any one beneath it.
- When jacking up the front of the vehicle, always place a 2 x 4 block (or similar material) between the jack and the machine frame.
- The jacking point at the front of the machine is under the front center frame support (Figure 35) and at the rear it is under the axle (Figure 36).

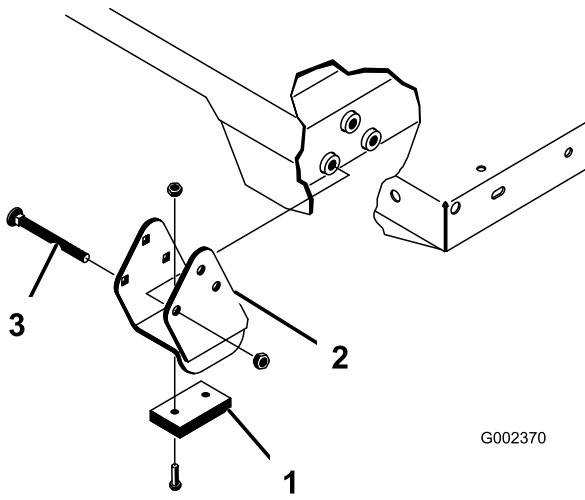

**Figure 34**

1. Wear block
2. Spacer bracket
3. Carriage bolt

1. Ensure that the lift cylinders are fully retracted.
2. Carefully set the bed onto the machine frame aligning the rear bed pivot-plate holes with the holes in the rear frame channel and install 2 clevis pins and lynch pins (Figure 34).
3. With the bed lowered, secure each cylinder rod end, to the appropriate slots in the bed-mounting plates with a clevis pin and lynch pin.
4. Insert the clevis pin from outside of the bed with the lynch pin toward the outside (Figure 34).

**Note:** The rear slots are for a full bed installation and front slots are for a 2/3 bed installation.

**Note:** The engine may need to be started to extend or retract the cylinders for alignment with the holes.

**Note:** The unused slot can be plugged with a bolt and nut to prevent assembly errors.

5. Start the engine and engage the hydraulic lift lever to raise the bed.
6. Release the lift lever and turn off the engine.
7. Install the bed safety support to prevent accidental lowering of the bed; refer to [Using the Bed Support](#) (page 34).
8. Install the lynch pins to the inside ends of the clevis pins.

**Note:** If the automatic tail gate release has been installed on the bed, ensure that the front dump link rod has been placed on the inside of the left side clevis pin before the lynch pin is installed.

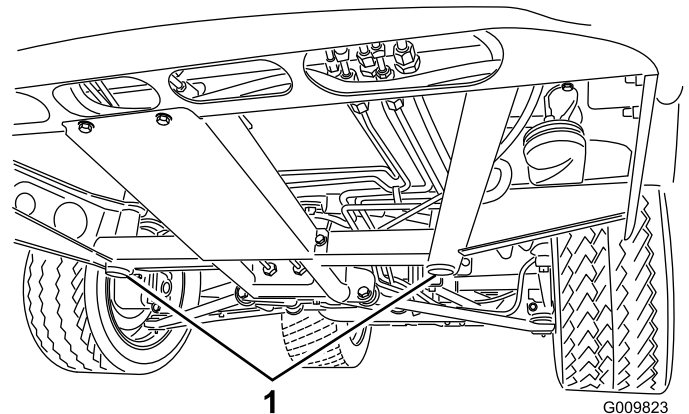

**Figure 35**

1. Front jacking points

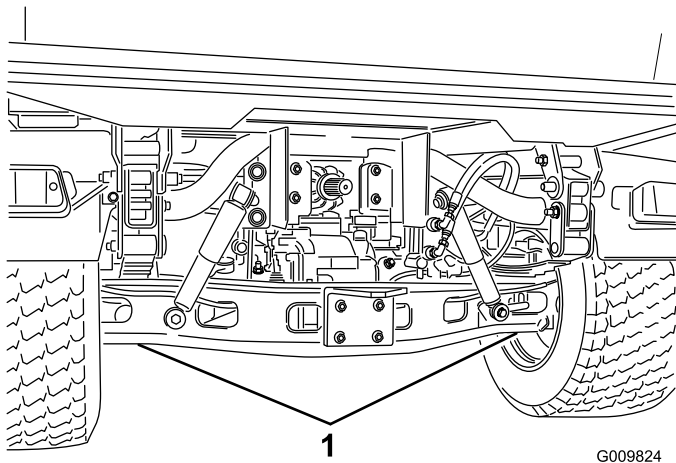

**Figure 36**

1. Rear jacking points

## Installing the Hood

1. Connect the lights.
2. Insert the top mounting tabs into the frame slots.
3. Insert the lower mounting tabs into the frame slots.
4. Ensure that the hood is fully engaged in the top, sides and bottom grooves.

## Removing the Hood

1. While grasping the hood in the headlight openings, lift up on the hood to release the lower mounting tabs from the frame slots (Figure 37).

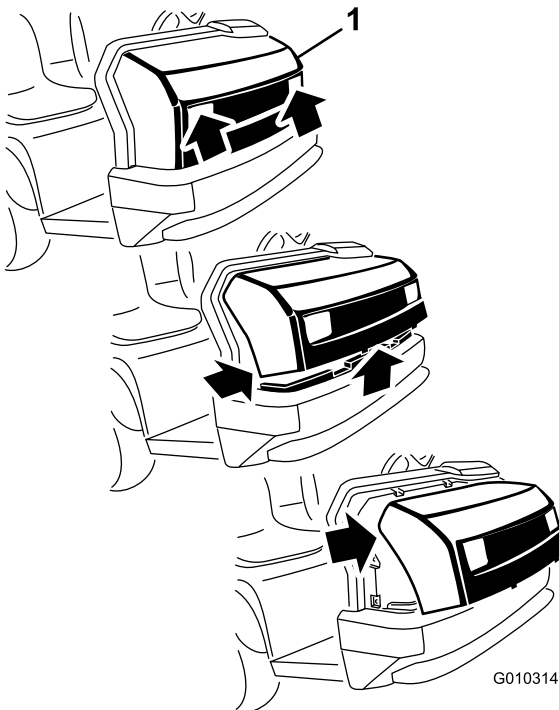

**Figure 37**

1. Hood
2. Pivot the bottom of the hood upward until the top mounting tabs can be pulled from the frame slots (Figure 37).
3. Pivot the top of the hood forward, and unplug the wire connectors from the head lights (Figure 37).
4. Remove the hood.

# Lubrication

## Greasing the Bearings and Bushings

**Service Interval:** Every 100 hours (lubricate more frequently in heavy duty applications).

The machine has grease fittings that must be lubricated regularly with No. 2 General Purpose Lithium-Base Grease.

The grease fitting locations and quantities are as follows:

- Ball joints (4), tie rods (2), pivot mounts (2) and steering cylinder (2) (Figure 38)
- Spring tower (2) (Figure 39)
- Clutch (1), accelerator (1), brake (qty.1) (Figure 40)
- U-joint (18) and 4 wheel drive shaft (3) (Figure 41)

**Important:** When greasing the drive shaft universal shaft bearing crosses, pump grease until it comes out of all 4 cups at each cross.

1. Wipe each grease fitting clean so foreign matter cannot be forced into the bearing or bushing.
2. Pump grease into each bearing or bushing.
3. Wipe off excess grease.

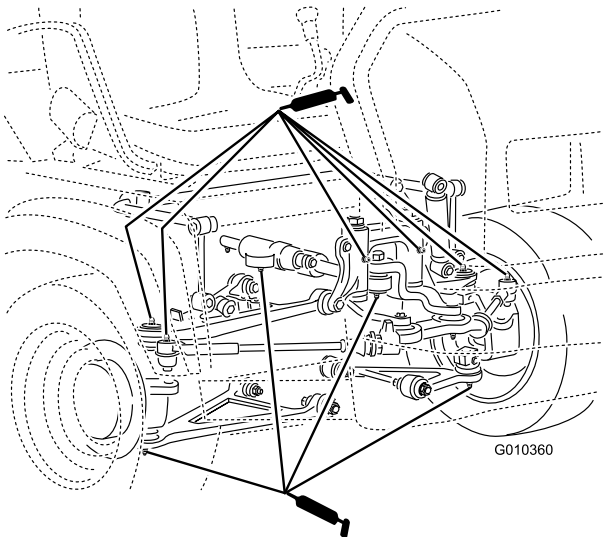

Figure 38

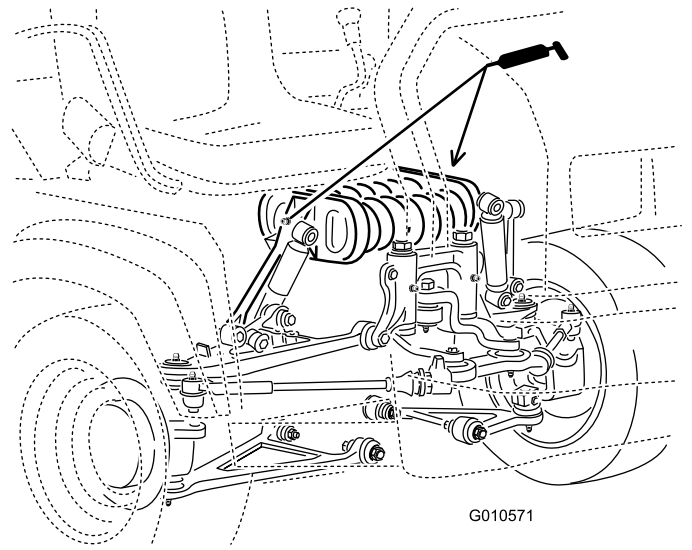

Figure 39

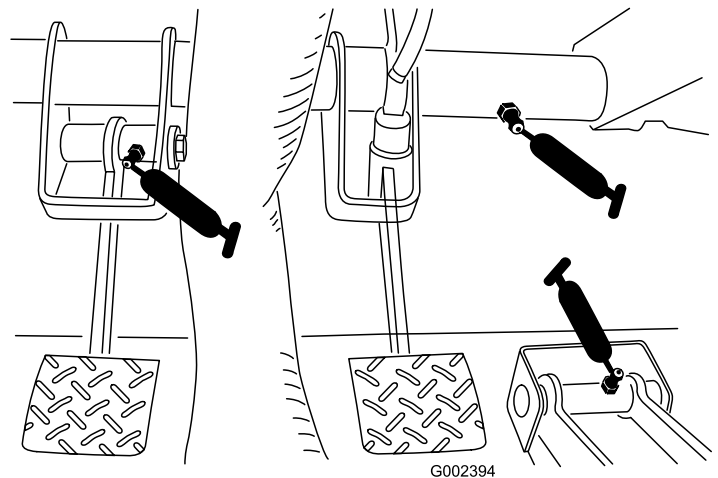
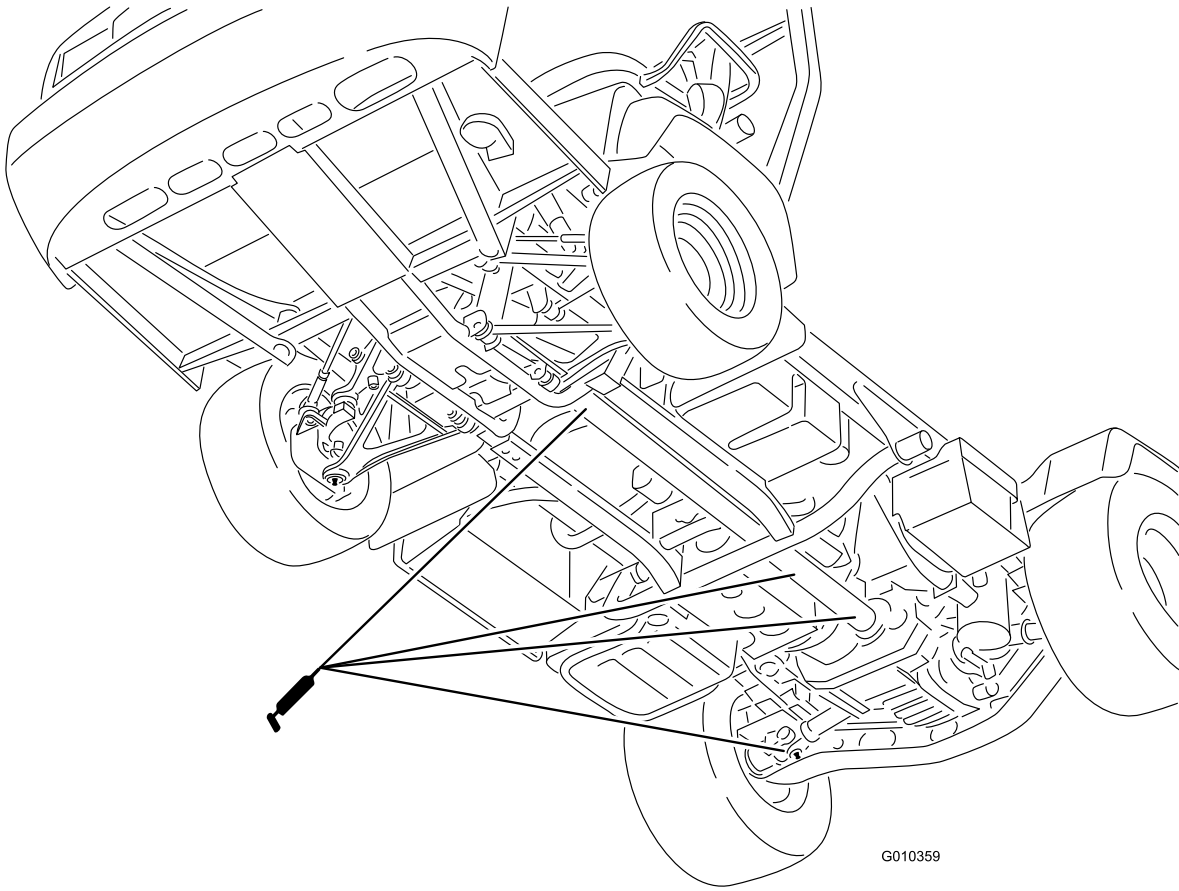

Figure 40



G010359

**Figure 41**

# Engine Maintenance

## Servicing the Air Cleaner

**Service Interval:** Before each use or daily—Check the air filter service indicator.

Every 25 hours

Every 600 hours—Change the safety air filter (more frequently in dusty or dirty conditions).

Inspect the air cleaner and hoses periodically to maintain maximum engine protection and to ensure maximum service life. Check the air-cleaner body for damage which could possibly cause an air leak. Replace a damaged air-cleaner body.

Inspect and change the air-cleaner filter as described in the following procedure:

1. Release the latches on the air cleaner and pull the air-cleaner cover off the air-cleaner body (Figure 42).

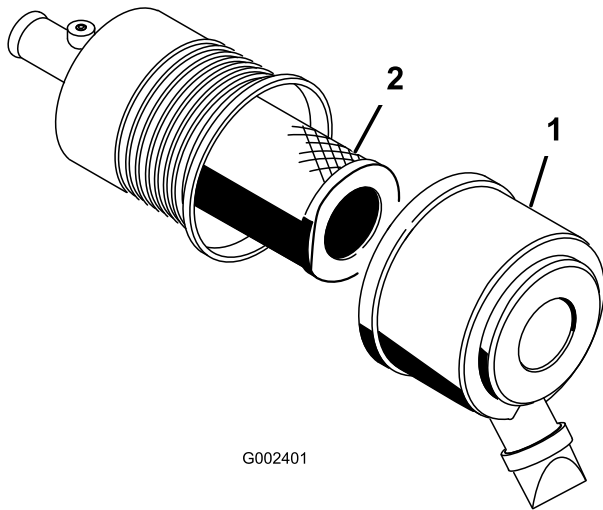

G002401

**Figure 42**

1. Air-cleaner cover
2. Filter

2. Squeeze the dust cap sides to open it and knock the dust out.
3. Gently slide the primary filter out of the air-cleaner body (Figure 42).

**Note:** Avoid knocking the filter into the side of the body.

**Note:** Do not attempt to clean the primary filter.

4. Remove the safety filter only if you intend to replace it.

**Important:** Never attempt to clean the safety filter. If the safety filter is dirty, then the primary filter is damaged and both filters should be replaced.

5. Inspect the new filter(s) for damage by looking into the filter while shining a bright light on the outside of the filter.

**Note:** Holes in the filter will appear as bright spots.

**Note:** Inspect the element for tears, an oily film, or damage to the rubber seal. If the filter is damaged do not use it.

6. If you are replacing the safety filter, carefully slide the new filter into the filter body (Figure 42).

**Note:** Take special care to keep particulates from dropping into the clean areas of the air filter housing.

**Note:** To prevent engine damage, always operate the engine with both air filters and cover installed.

7. Carefully slide the primary filter over the safety filter (Figure 42).

**Note:** Ensure that it is fully seated by pushing on the outer rim of the filter while installing it.

8. Install the air-cleaner cover with the side facing up, and secure the latches (Figure 42).

## Changing the Engine Oil and Filter

**Service Interval:** After the first 50 hours

Every 100 hours

**Engine oil capacity:** 3.2 L (3.4 US qt)

**Engine oil type:** Detergent diesel engine oil API CH-4 or higher

**Engine-oil viscosity:** Choose an engine-oil viscosity according to the ambient-air temperature to the table in Figure 43.

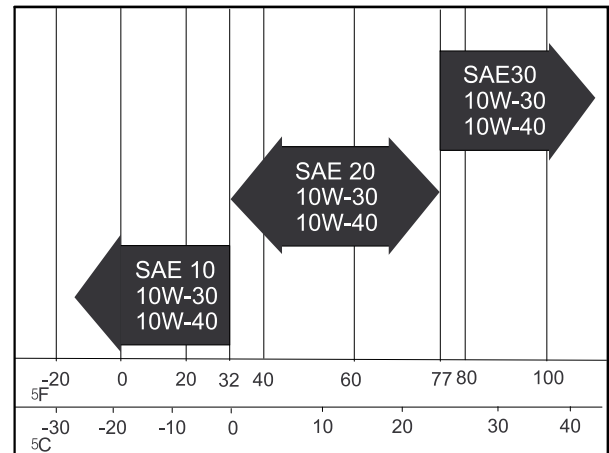

G001061

**Figure 43**

1. Raise the bed and place the safety support on the extended-lift cylinder to hold up the bed.
2. Remove the drain plug and let oil flow into a drain pan (Figure 44).



# Fuel System Maintenance

## Checking the Fuel Lines and Connections

**Service Interval:** Every 400 hours/Yearly (whichever comes first)

Every 1,000 hours/Every 2 years (whichever comes first)

Inspect the fuel lines and connections for deterioration, damage, or loose connections.

## Servicing the Fuel Filter/Water Separator

### Draining the Fuel Filter/Water Separator

**Service Interval:** Before each use or daily—Drain water or other contaminants from the water separator.

1. Place a clean container under the fuel filter ([Figure 46](#)).
2. Loosen the drain plug on the bottom of the filter canister.

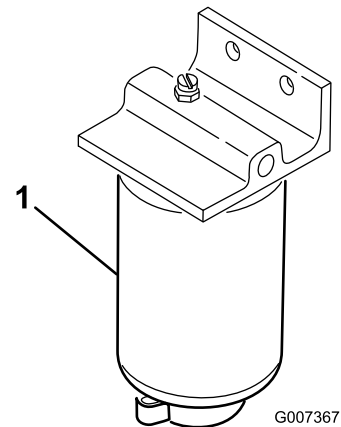

**Figure 46**

1. Water separator filter canister

3. Tighten the drain plug on the bottom of the filter canister.

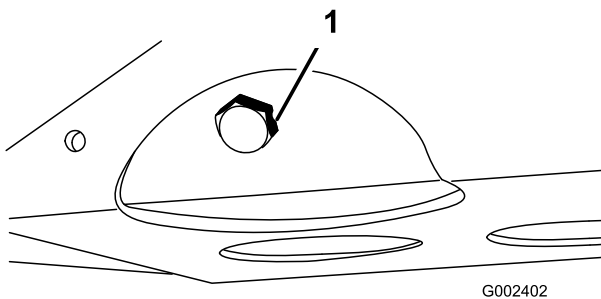

**Figure 44**

1. Engine oil-drain plug

3. When the oil stops, install the drain plug.
4. Remove the oil filter ([Figure 45](#)).

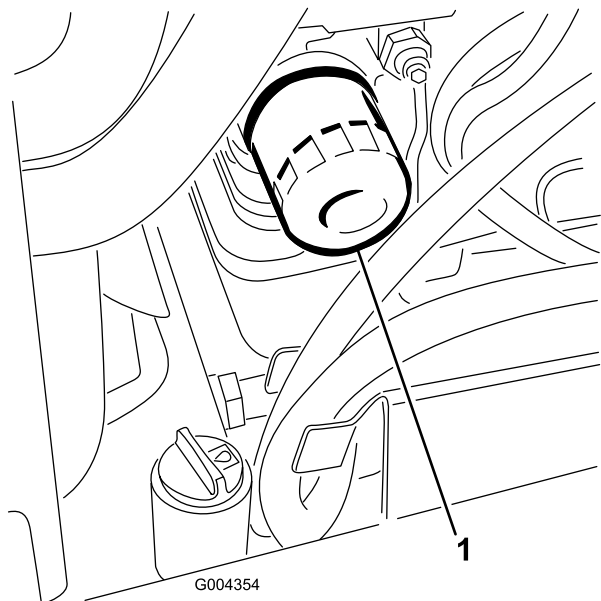

**Figure 45**

1. Engine-oil filter

5. Apply a light coat of clean oil to the new filter seal before screwing it on.
6. Screw the filter on until the gasket contacts the mounting plate, then tighten the filter 1/2 to 2/3 of a turn.

**Note:** Do not overtighten.

7. Add oil to the crankcase; refer to [Checking the Engine-oil Level](#) (page 19).

## Changing the Fuel-filter Canister

**Service Interval:** Every 400 hours—Replace the fuel-filter canister.

1. Drain the water from the water separator; refer to [Draining the Fuel Filter/Water Separator](#) (page 41).
2. Clean the area where the filter-canister mounts ([Figure 46](#)).
3. Remove the filter canister and clean the mounting surface.
4. Lubricate the gasket on the filter canister with clean oil.
5. Install the filter canister by hand until the gasket contacts mounting surface, then rotate it an additional 1/2 turn.
6. Tighten the drain plug on the bottom of the filter canister.

## Electrical System Maintenance

### Servicing the Fuses

The fuses for the electrical system are located under the center of the dash panel ([Figure 47](#) and [Figure 48](#)).

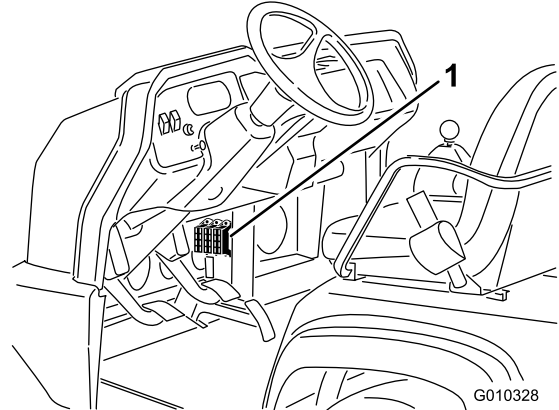

**Figure 47**

1. Fuses

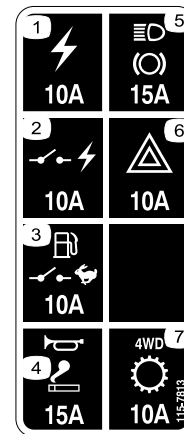

**Figure 48**

- |                                     |                          |
|-------------------------------------|--------------------------|
| 1. Power outlet—10A                 | 5. Lights, brake—15A     |
| 2. Switched power—10A               | 6. Hazard—10A            |
| 3. Fuel pump, supervisor switch—10A | 7. 4WD, Transmission—10A |
| 4. Horn, power point—15A            |                          |

# Jump Starting the Machine

## ⚠ WARNING

Jump starting can be dangerous. To avoid personal injury or damage to electrical components in machine, observe the following warnings:

- Never jump start with a voltage source greater than 15 volts DC. This will damage the electrical system.
- Never attempt to jump start a discharged battery that is frozen. It could rupture or explode during jump starting.
- Observe all battery warnings while jump starting your machine.
- Be sure your machine is not touching the jump start machine.
- Connecting cables to the wrong post could result in personal injury and/or damage to the electrical system.

1. Squeeze the battery cover to release the tabs from battery base, and remove the battery cover from the battery base (Figure 49).

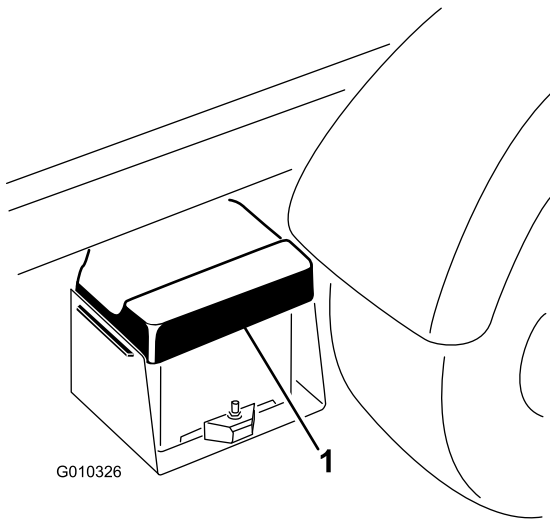

Figure 49

1. Battery cover

2. Connect a jumper cable between the positive posts of the 2 batteries (Figure 50). The positive post may be identified by a + sign on top of the battery cover.
3. Connect one end of the other jumper cable to the negative terminal of the battery in the other machine.

**Note:** The negative terminal has NEG on the battery cover.

**Note:** Do not connect the other end of the jumper cable to the negative post of the discharged battery.

Connect the jumper cable to the engine or frame. Do not connect the jumper cable to the fuel system.

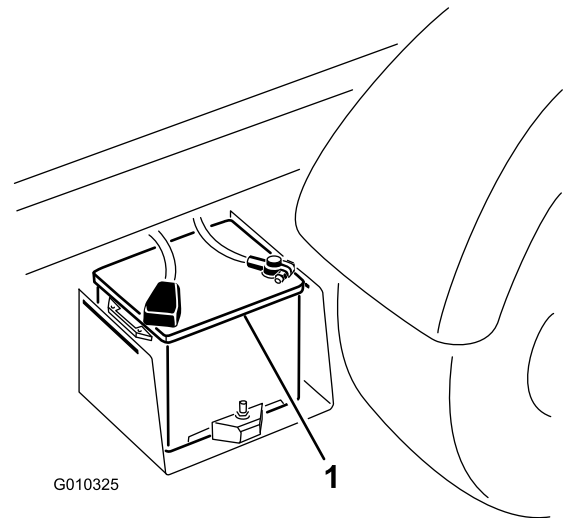

Figure 50

1. Battery

4. Start the engine in the machine providing the jump start.

**Note:** Let it run a few minutes, then start your engine.

5. Remove the negative jumper cable first from your engine, then the battery in the other machine.
6. Install the battery cover to the battery base.

## Servicing the Battery

**Service Interval:** Every 50 hours—Check the battery-fluid level (every 30 days if in storage).

Every 50 hours—Check the battery-cable connections.

### ⚠ WARNING

#### CALIFORNIA Proposition 65 Warning

Battery posts, terminals, and related accessories contain lead and lead compounds, chemicals known to the State of California to cause cancer and reproductive harm.  
Wash hands after handling.

### ⚠ DANGER

Battery electrolyte contains sulfuric acid which is a deadly poison and causes severe burns.

- Do not drink electrolyte and avoid contact with skin, eyes or clothing. Wear safety glasses to shield your eyes and rubber gloves to protect your hands.
- Fill the battery where clean water is always available for flushing the skin.
- Keep the battery-electrolyte level properly maintained.
- Keep the top of the battery clean by washing it periodically with a brush dipped in ammonia or bicarbonate of soda solution. Flush the top surface with water after cleaning. Do not remove the fill cap while cleaning.
- Ensure that the battery cables are kept tight on the terminals to provide good electrical contact.
- If corrosion occurs at terminals, remove the battery cover, disconnect the cables (negative (-) cable first), and scrape the clamps and terminals separately. Reconnect the cables (positive (+) cable first) and coat the terminals with petroleum jelly.
- Maintain cell electrolyte level with distilled or demineralized water. Do not fill the cells above the bottom of the fill ring inside each cell.
- If you store the machine in a location where temperatures are extremely high, the battery will run down more rapidly than if the machine is stored in a location where temperatures are cool.

## Drive System Maintenance

### Changing the Front-differential Oil (4-wheel drive models only)

**Service Interval:** Every 800 hours

**Differential-oil specification:** Mobil 424 hydraulic oil

1. Position the machine on a level surface, stop the engine, set the parking brake and remove the key from the starter switch.
2. Clean the area around the drain plug on the side of the differential (Figure 51).
3. Place a drain pan under the drain plug.

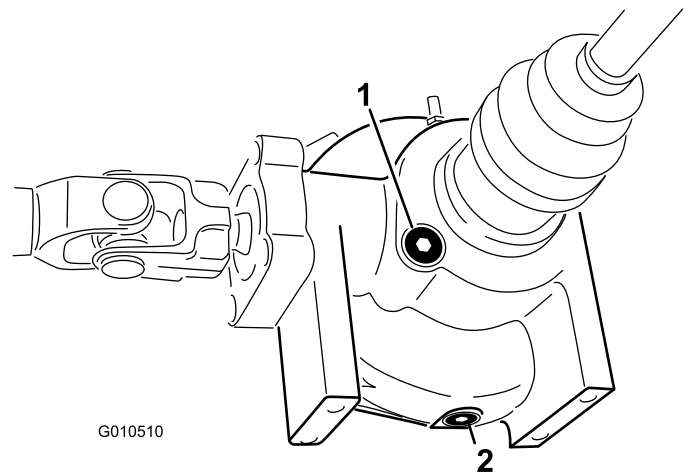

Figure 51

1. Fill/check plug

2. Drain plug

4. Remove the drain plug and let the oil flow into the drain pan.
5. Install and tighten the plug when the oil stops draining.
6. Clean the area around the fill/check plug on the bottom of the differential.
7. Remove the fill/check plug and add specified oil until the oil level is up to the hole.
8. Install the fill/check plug.

### Inspecting the Constant-velocity Boot (4-wheel drive models only)

**Service Interval:** Every 200 hours

Inspect the constant-velocity boot for cracks, holes, or a loose clamp. Contact your Authorized Toro Distributor for repair if you find any damage.

# Adjusting the Shift Cables

**Service Interval:** After the first 10 hours

Every 200 hours

1. Move the shift lever to the Neutral position.
2. Remove the clevis pins securing the shift cables to the transaxle-shift arms (Figure 52).

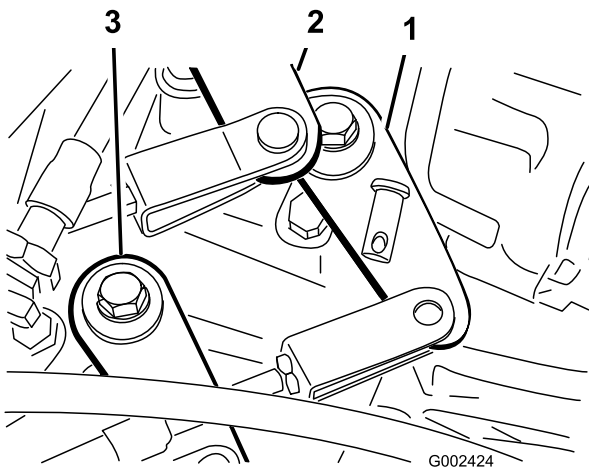

**Figure 52**

1. Shift arm (1st to reverse)
2. Shift arm (2nd to 3rd)
3. Shift arm (High to low)

3. Loosen the clevis jam nuts and adjust each clevis, so that the cable free play is equal forward and backward relative to the hole in the transaxle-shift arm (with the transaxle lever free play taken up in the same direction).
4. Install the clevis pins and tighten the jam nuts when finished.

# Adjusting the High-to-Low Cable

**Service Interval:** Every 200 hours

1. Remove the clevis pin securing the high-to-low cable to the transaxle (Figure 52).
2. Loosen the clevis jam nut and adjust the clevis so that the clevis hole aligns with the hole in the transaxle bracket.
3. Install the clevis pin and tighten the jam nut when finished.

# Adjusting Differential-lock Cable

**Service Interval:** Every 200 hours

1. Move the differential-lock lever to the Off position.
2. Loosen the jam nuts securing the differential-lock cable to the bracket on the transaxle (Figure 53).

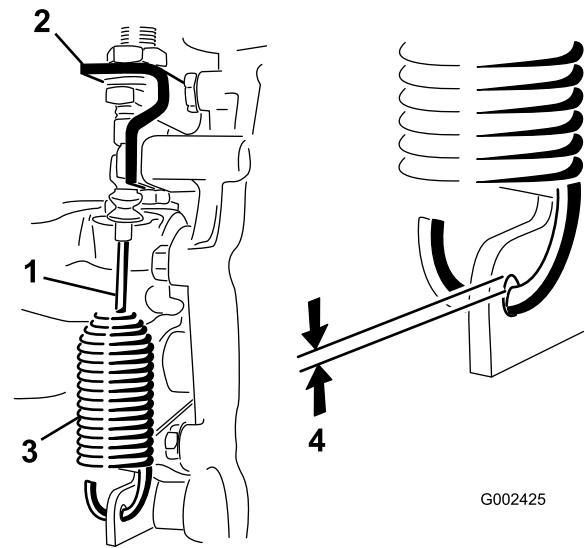

**Figure 53**

1. Differential-lock cable
2. Transaxle bracket
3. Spring
4. 0.25 to 1.5 mm (0.01 to 0.06 inch) gap

3. Adjust the jam nuts to obtain a 0.25 to 1.5 mm (0.01 to 0.06 inch) gap between the spring hook and the OD of the hole in the transaxle lever.
4. Tighten the jam nuts when finished.

# Inspecting the Tires

**Service Interval:** Every 100 hours

Operating accidents, such as hitting curbs, can damage a tire or rim and also disrupt wheel alignment, so inspect the tire condition after an accident.

Check the tire pressure frequently to ensure proper inflation. If the tires are not inflated to the correct pressure, the tires will wear prematurely.

Figure 54 is an example of tire wear caused by under inflation.

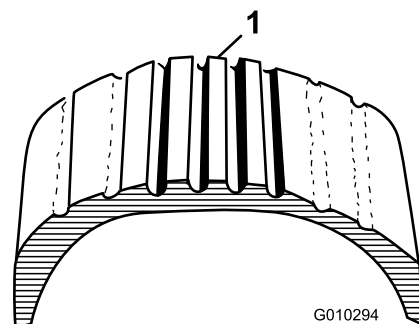

**Figure 54**

1. Under-inflated tire

Figure 55 is an example of tire wear caused by over inflation.

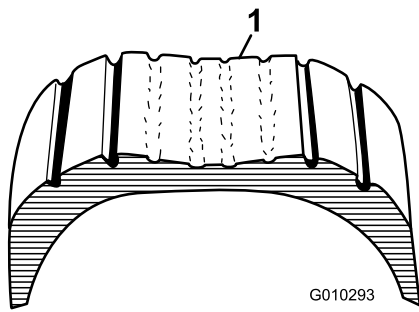

Figure 55

1. Over-inflated tire

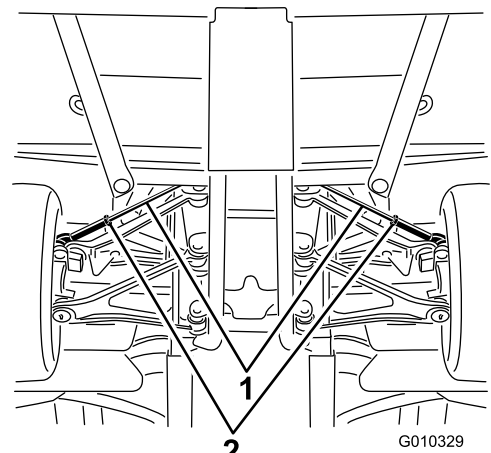

Figure 57

1. Tie rods
2. Jam nuts

## Checking the Front Wheel Alignment

**Service Interval:** Every 400 hours/Yearly (whichever comes first)

1. Make sure the tires are facing straight ahead.
2. Measure the center-to-center distance (at axle height) at the front and rear of the steering tires (Figure 56).

**Note:** The measurement must be within  $0 \pm 3$  mm ( $0 \pm 0.12$  inch) at the front of the tire then at the rear of the tire. Rotate the tire  $90^\circ$  and check the measurement.

**Important:** Check the measurements at consistent locations on the tire. The machine should be on a flat surface with the tires facing straight ahead.

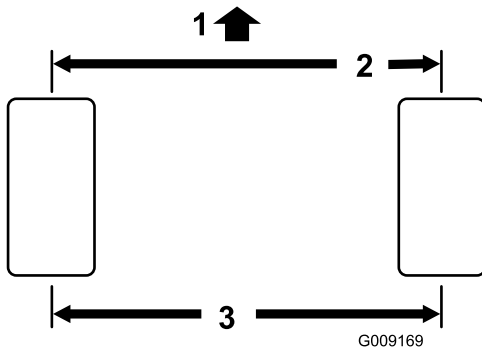

Figure 56

1. Front of the machine
2.  $0 \pm 3$  mm ( $0 \pm 0.12$  inch) front to rear of the tire
3. Center to center distance

- B. Rotate the tie rod to move the front of the tire inward or outward to achieve the center to center distances from front to back.
- C. Tighten the tie rod jam nut when the adjustment is correct.
- D. Check to ensure that the tires turn an equal amount to the right and to the left.

**Note:** If the tires do not turn equally, refer to the *Service Manual* for the adjustment procedure.

3. Adjust the center-to-center distance as follows:
  - A. Loosen the jam nut at the center of the tie rod (Figure 57).

# Cooling System Maintenance

## Removing Debris from the Cooling System

**Service Interval:** Before each use or daily (clean more frequently in dirty conditions).

1. Turn the engine off and clean the engine area thoroughly of all debris.
2. Unlatch and remove the radiator screen from the front of the radiator (Figure 58).

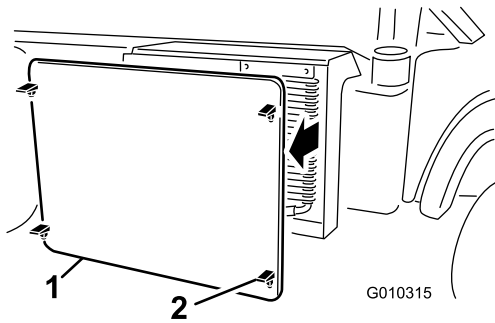

Figure 58

1. Radiator screen
2. Latch

3. If so equipped, rotate the latches and pivot the oil cooler away from the radiator (Figure 59).

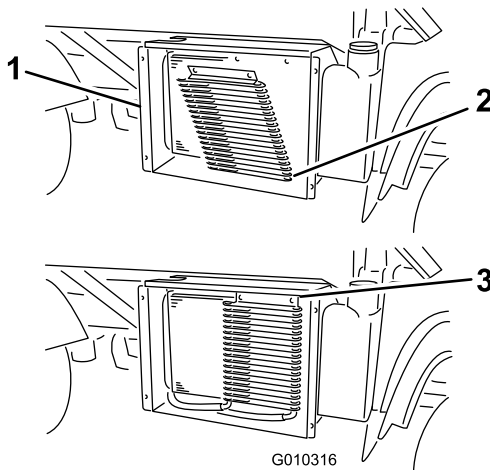

Figure 59

1. Radiator housing
2. Oil cooler
3. Latches

4. Clean the radiator, oil cooler, and screen thoroughly with compressed air.

**Note:** Blow debris away from the radiator. Do not use water to clean external surfaces of the radiator.

5. Install the cooler and screen to the radiator.

## Changing the Engine Coolant

**Service Interval:** Every 1,000 hours/Every 2 years (whichever comes first)

**Coolant type:** 50/50 mixture of water and permanent ethylene-glycol antifreeze

1. Park the machine on a level surface.
2. Raise the bed (if so equipped) and place the safety support on the extended-lift cylinder to hold up the bed.

### CAUTION

If the engine has been running, the pressurized, hot coolant can escape and cause burns.

- Do not open the radiator cap when the engine is running.
- Allow engine to cool at least 15 minutes or until the radiator cap is cool enough to touch without burning your hand.
- Use a rag when opening the radiator cap, and open the cap slowly to allow steam to escape.

3. Remove the radiator cap.

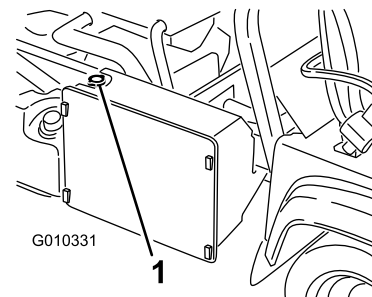
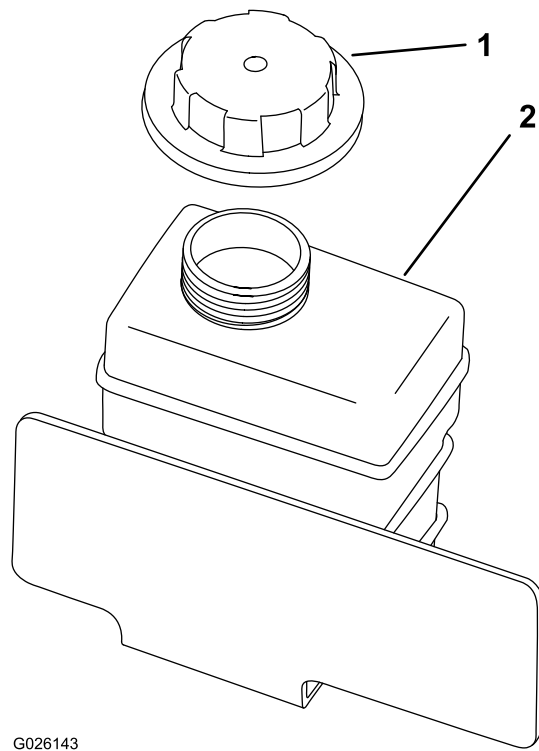

Figure 60

1. Radiator cap

4. Remove the reserve-tank cap (Figure 61).





G026143

**Figure 61**

1. Reserve tank-cap
2. Reserve tank

5. Disconnect the lower radiator hose and allow coolant to flow into a drain pan.
6. When coolant stops, connect the lower radiator hose.
7. Remove the coolant-drain plug from the engine and allow coolant to flow into a drain pan.
8. When coolant stops, install the drain plug.
9. Slowly fill the radiator with a 50/50 mixture of water and permanent ethylene-glycol antifreeze
10. Install the radiator cap.
11. Fill the reservoir tank to the bottom of the filler neck.
12. Start the engine and allow it to idle.
13. As air escapes, fill the reservoir to the bottom of the filler neck.

**Note:** Do not allow the engine to heat up to the running temperature.

14. Install the reservoir-tank cap.
15. Run the machine until it reaches the operating temperature.
16. Turn off the machine and allow it to cool.
17. Check the coolant level again, and replenish it, if required.

# Brake Maintenance

## Adjusting the Parking Brake

**Service Interval:** After the first 10 hours

Every 200 hours

1. Remove the rubber grip from the parking-brake lever (Figure 62).

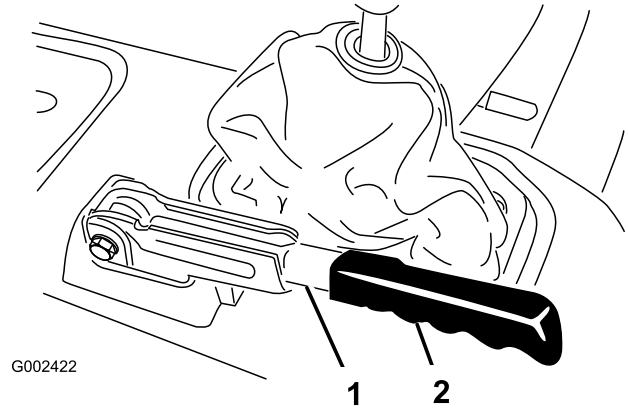

G002422

**Figure 62**

1. Parking-brake lever
2. Grip

2. Loosen the set screw securing the knob to the parking brake lever (Figure 63).
3. Rotate the knob until a force of 20 to 22 kg (45 to 50 lb) is required to actuate the lever.

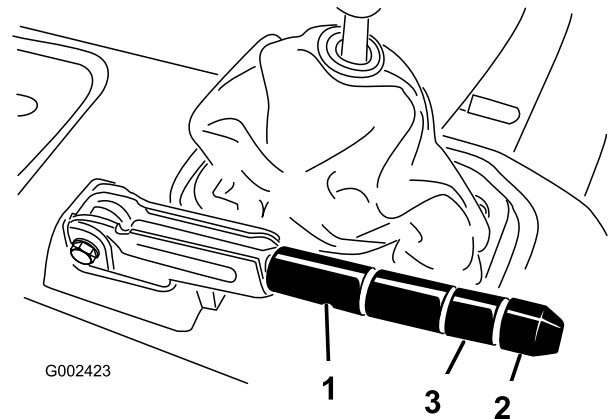

G002423

**Figure 63**

1. Parking-brake lever
2. Knob
3. Set screw

4. Tighten the set screw when finished.

**Note:** If no adjustment is left at the handle, loosen the handle to the middle of the adjustment and adjust the cable at the rear, then repeat step 3.

5. Install the rubber grip onto the parking-brake lever.



# Adjusting the Brake Pedal

**Service Interval:** Every 200 hours

**Note:** Remove the front hood to ease the adjustment procedure.

1. Remove the cotter pin and clevis pin securing the master cylinder yoke to the brake-pedal pivot (Figure 64).

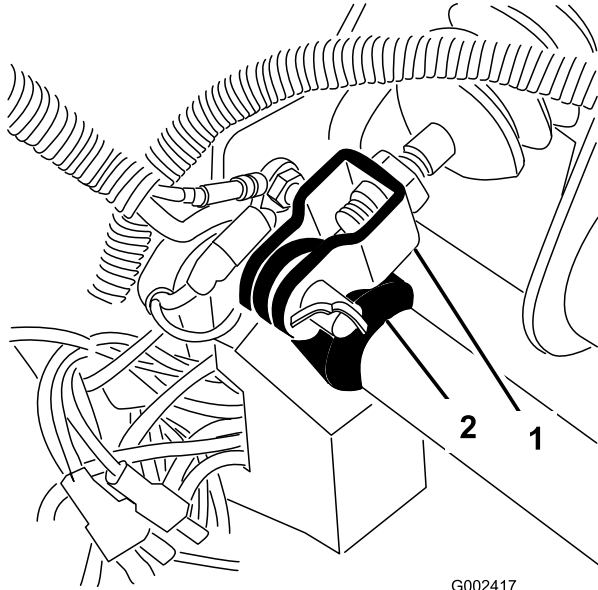

**Figure 64**

1. Master cylinder yoke
2. Brake-pedal pivot

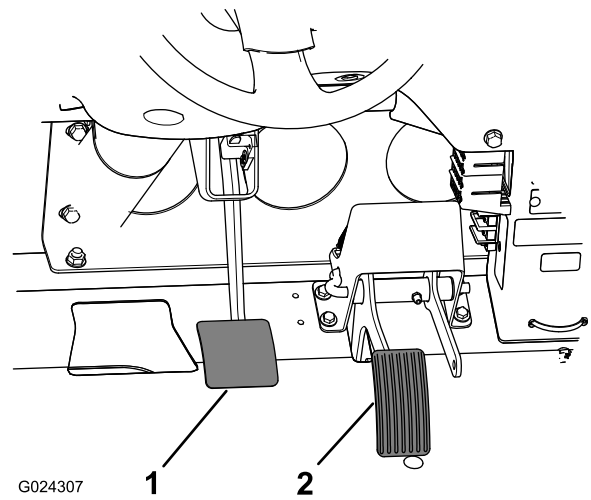

**Figure 65**

1. Brake pedal
2. Accelerator pedal

2. Lift up on the brake pedal (Figure 65) until it contacts the frame.
3. Loosen the jam nuts securing the yoke to the master cylinder shaft (Figure 65).
4. Adjust the yoke until its holes align with the hole in the brake-pedal pivot.
5. Secure the yoke to the pedal pivot with the clevis pin and cotter pin.
6. Tighten the jam nuts securing the yoke to the master cylinder shaft.

**Note:** The brake master cylinder must relieve pressure when properly adjusted.

# Belt Maintenance

## Adjusting the Alternator Belt

**Service Interval:** After the first 8 hours—Check the condition and tension of the alternator belt.

Every 200 hours—Check the condition and tension of the alternator belt.

1. Raise the bed (if so equipped) and position the safety support on the extended-lift cylinder to hold up the bed.
2. Check the tension by pressing the belt at mid span between the crankshaft and alternator pulleys with 10 kg (22 lb) of force (Figure 66).

**Note:** A new belt should deflect 8 to 12 mm (0.3 to 0.5 inch).

**Note:** A used belt should deflect 10 to 14 mm (0.4 to 0.55 inch). If the deflection is incorrect, proceed to the next step. If correct, continue operation.

3. To adjust belt tension, complete the following:
  - A. Loosen the 2 alternator-mounting bolts (Figure 66).

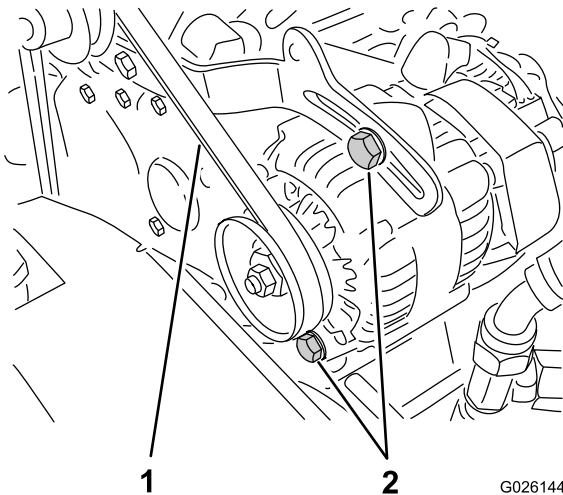

Figure 66

1. Alternator belt
2. Alternator-mounting bolts

- B. Using a pry bar, rotate the alternator until the proper belt tension is attained, then tighten the mounting bolts (Figure 66).

# Controls System Maintenance

## Adjusting the Accelerator Pedal

1. Position the machine on a level surface, stop the engine, and engage the parking brake.
2. Adjust the ball joint on the accelerator cable (Figure 67) to allow 2.54 to 6.35 mm (0.100 to 0.250 inch) of clearance between the accelerator-pedal arm and the top of the diamond tread floor plate (Figure 68), when a 11.3 kg (25 lb) force is applied to the center of the pedal.

**Note:** The engine must not be running and the return spring must be attached.

3. Tighten the locknut (Figure 67).

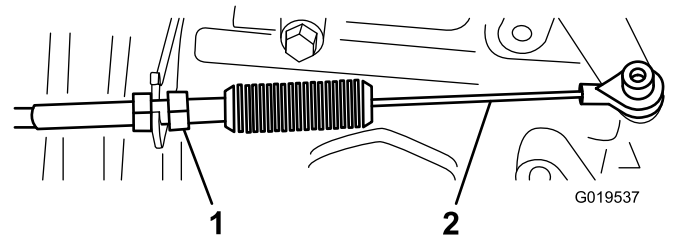

Figure 67

1. Locknut
2. Accelerator cable

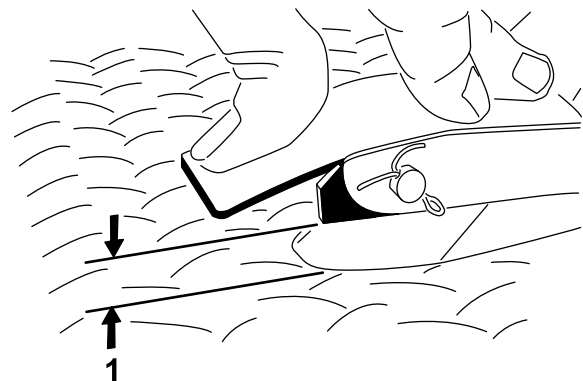

Figure 68

1. 2.54 to 6.35 mm (0.100 to 0.250 inch) clearance

**Important:** The maximum high idle speed is 3,650 rpm. The high idle stop should not be adjusted.

# Adjusting the Clutch Pedal

**Service Interval:** Every 200 hours

**Note:** You can adjust the clutch-pedal cable at the bell housing or at the clutch-pedal pivot. The front hood can be removed to ease the access to the pedal pivot.

1. Loosen the jam nuts securing the clutch cable to the bracket on the bell housing (Figure 69).

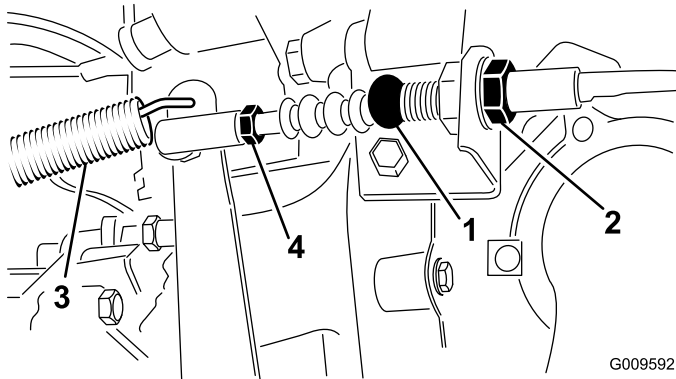
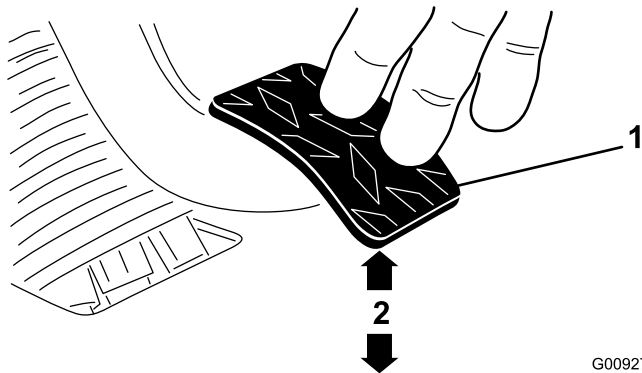

**Figure 69**

- |                 |                  |
|-----------------|------------------|
| 1. Clutch cable | 3. Return spring |
| 2. Jam nuts     | 4. Ball joint    |

**Note:** You may remove and rotate the ball joint, if additional adjustment is required.

2. Disconnect the return spring from the clutch lever.
3. Adjust the jam nuts or ball joint until the back, rear edge of the clutch pedal is  $9.5 \pm 0.3$  cm ( $3.75 \pm 0.12$  inch) from the top of the floor plate diamond pattern, when an 1.8 kg (4 lb) force is applied to the pedal (Figure 70).



**Figure 70**

- |                 |   |
|-----------------|---|
| 1. Clutch pedal | 2. $9.5 \pm 0.3$ cm ( $3.75 \pm 0.12$ inch) |
|-----------------|---|

**Note:** Force is applied so the clutch release bearing lightly contacts the pressure plate fingers.

4. Tighten the jam nuts after the adjustment has been attained.
5. Check the  $9.5 \pm 0.3$  cm ( $3.75 \pm 0.12$  inch) dimension after the jam nuts have been tightened to ensure proper adjustment.

**Note:** Adjust again if it is necessary.

6. Connect the return spring to the clutch lever.

**Important:** Ensure that the rod end is positioned squarely on the ball, not twisted, and remains parallel to the clutch pedal after the jam nut is tightened (Figure 71).

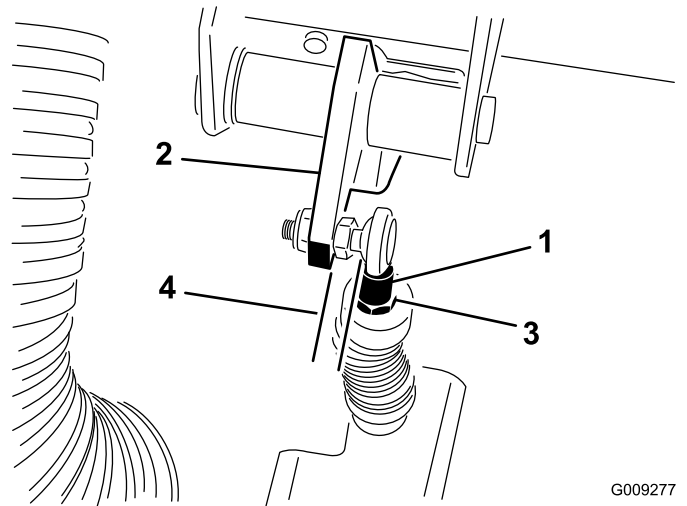

**Figure 71**

- |                         |                    |
|-------------------------|--------------------|
| 1. Clutch-cable rod end | 3. Rod end jam nut |
| 2. Clutch pedal         | 4. Parallel        |

**Note:** The clutch free play should never be less than 19 mm (0.75 inch).

## Converting the Speedometer

You can convert the speedometer from mph to km/h or km/h to mph.

1. Position the machine on a level surface, stop the engine, engage the parking brake, and remove the key from the starter switch.
2. Remove the hood; refer to [Removing the Hood \(page 37\)](#).
3. Locate the 2 loose wires next to the speedometer.
4. Remove the connector plug from the harness wire and connect the wires together.

**Note:** The speedometer will switch to km/h or mph.

5. Install the hood.

# Hydraulic System Maintenance

## Changing the Hydraulic fluid and Cleaning the Strainer

**Service Interval:** Every 800 hours

**Hydraulic-fluid capacity:** approximately 7 L (7.5 US qt)

**Hydraulic-fluid type:** Dexron III ATF

1. Position the machine on a level surface, stop the engine, engage the parking brake, and remove the key from the starter switch.
2. Remove the drain plug from the side of the reservoir, and let the hydraulic fluid flow into a drain pan (Figure 72).

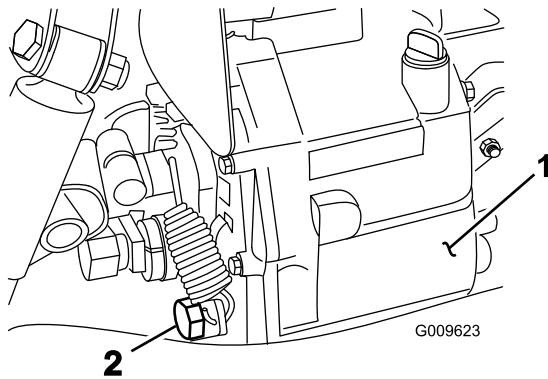

1. Hydraulic reservoir      2. Drain plug

3. Note the orientation of the hydraulic hose and 90° fitting connected to the strainer on the side of the reservoir (Figure 73).
4. Remove the hydraulic hose and 90° fitting.
5. Remove the strainer and clean it by back flushing it with a clean de-greaser.

**Note:** Allow it to air dry before installing.

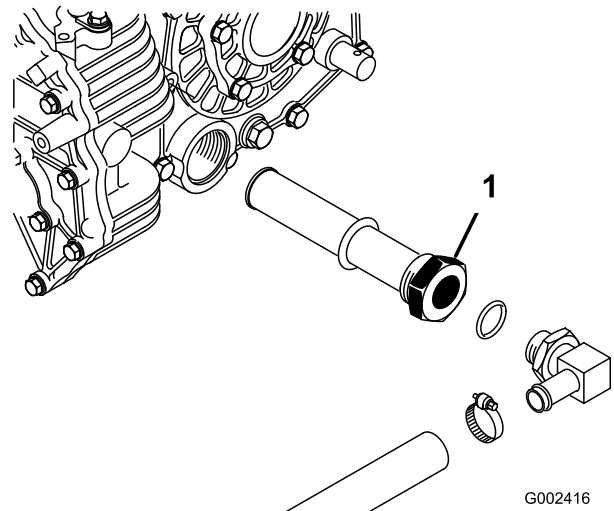

**Figure 73**

1. Hydraulic strainer

6. Install the strainer.
7. Install the hydraulic hose and 90° fitting to the strainer in the same orientation.
8. Install and tighten the drain plug.
9. Fill the reservoir with approximately 7 L (7.5 US qt) of the specified hydraulic fluid; refer to [Checking the Transaxle/Hydraulic-fluid Level \(page 21\)](#).
10. Start the engine and operate the machine to fill the hydraulic system.
11. Check the hydraulic fluid level and replenish it, if required.

**Important:** Use only the hydraulic fluid specified. Other fluids could cause system damage.

## Replacing the Hydraulic Filter

**Service Interval:** After the first 10 hours

Every 800 hours

**Important:** Use of any other filter may void the warranty on some components.

1. Position the machine on a level surface, stop the engine, engage the parking brake, and remove the key from starter switch.
2. Clean the area around filter mounting area.
3. Place a drain pan under the filter and remove the filter (Figure 74).

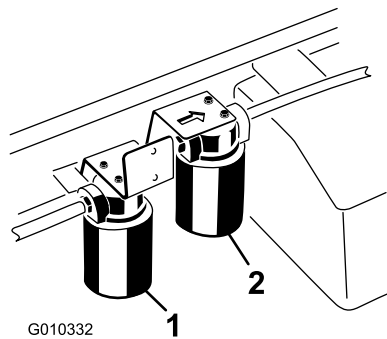

Figure 74

1. Hydraulic filter                      2. High-flow hydraulic filter

4. Lubricate the gasket on the new filter.
5. Ensure that the filter mounting area is clean.
6. Screw the filter on until the gasket contacts the mounting plate, and tighten the filter 1/2 turn.
7. Start the engine and let it run for about 2 minutes to purge air from the system.
8. Stop the engine and check the hydraulic-oil level and for leaks.

## Changing the High-flow Hydraulic fluid and Filter (TC models only)

**Service Interval:** After the first 10 hours—Change the high-flow hydraulic fluid filter (TC models only).

Every 800 hours—Change the high-flow hydraulic fluid and filter (TC models only).

**Hydraulic-fluid capacity:** approximately 15 L (4 US gallons)

**Hydraulic-fluid type:** Toro Premium All Season Hydraulic Fluid (Available in 5 gallon pails or 55 gallon drums. See parts catalog or Toro distributor for part numbers.)

**Alternate fluids:** If the Toro fluid is not available, another conventional petroleum-based fluid may be used provided it meets the following material properties and industry specifications. Consult with your lubricant distributor to identify a satisfactory product.

**Note:** Toro will not assume responsibility for damage caused by improper substitutions, so use only products from reputable manufacturers who will stand behind their recommendation.

**High Viscosity Index/Low Pour Point Antiwear Hydraulic Fluid, ISO VG 46**

### Material Properties:

- Viscosity—ASTM D445 cSt @ 40°C: 44 to 48/cSt @ 100°C: 7.9 to 8.5
- Viscosity Index, ASTM D2270—140 to 152

- Pour Point, ASTM D97— -35°F to -46°F
- FZG, Fail stage—11 or better
- Water content (new fluid)—500 ppm (maximum)

### Industry Specifications:

Vickers I-286-S, Vickers M-2950-S, Denison HF-0, Vickers 35 VQ 25 (Eaton ATS373-C)

**Note:** Many hydraulic fluids are almost colorless, making it difficult to spot leaks. A red dye additive for the hydraulic system fluid is available in 20 ml (2/3 oz.) bottles. One bottle is sufficient for 15–22 l (4–6 gal) of hydraulic fluid. Order part no. 44-2500 from your authorized Toro distributor.

**Note:** If the fluid becomes contaminated, contact your local Toro distributor because the system must be flushed. Contaminated fluid may look milky or black when compared to clean fluid. The service interval may need to be increased if using multiple attachments as the fluid may become contaminated quicker with the mixing of different hydraulic fluids.

1. Clean the area around the high-flow-filter mounting area (Figure 74).
2. Place a drain pan under the filter and remove the filter.

**Note:** If the fluid is not going to be drained, disconnect and plug the hydraulic line going to the filter.

3. Lubricate the new filter-sealing gasket and hand turn the filter onto the filter head until the gasket contacts the filter head. Then tighten it 3/4 turn further. The filter should now be sealed.
4. Fill the hydraulic reservoir with approximately 15 L (4 US gallons) of hydraulic fluid.
5. Start the machine and run it at idle for about 2 minutes to circulate the fluid and remove any air trapped in the system.
6. Stop the machine and check the fluid level.
7. Verify the fluid level.
8. Dispose of the fluid properly.

## Raising the Cargo Box in an Emergency

The cargo box can be raised in an emergency without starting the engine by cranking starter or by jumping hydraulic system.

### Raising the Cargo Box using the Starter

Crank the starter while holding the lift lever in the Raise position. Run the starter for 10 seconds, then wait 60 seconds before engaging the starter again. If the engine will not crank, you must remove the load and box (attachment) to service the engine or transaxle.

# Raising the Cargo Box by Jumping the Hydraulic System

## ⚠ CAUTION

Before servicing or making adjustments to the machine, stop the engine, set the parking brake, and remove the key from the switch. Remove all load material that is loaded into the bed or other attachment before working under a raised bed. Never work under a raised bed without positioning the safety support on the fully extended cylinder rod.

2 hydraulic hoses, each with a male and female quick coupler, that fit the vehicle couplers are required to perform this operation.

1. Back another machine up to the rear of the disabled machine.

**Important:** The machine hydraulic system uses Dexron III ATF. To avoid system contamination, make sure the vehicle used to jump the hydraulic system uses an equivalent fluid.

2. On both machine, disconnect the 2 quick-coupler hoses from the hoses secured to the coupler bracket (Figure 75).

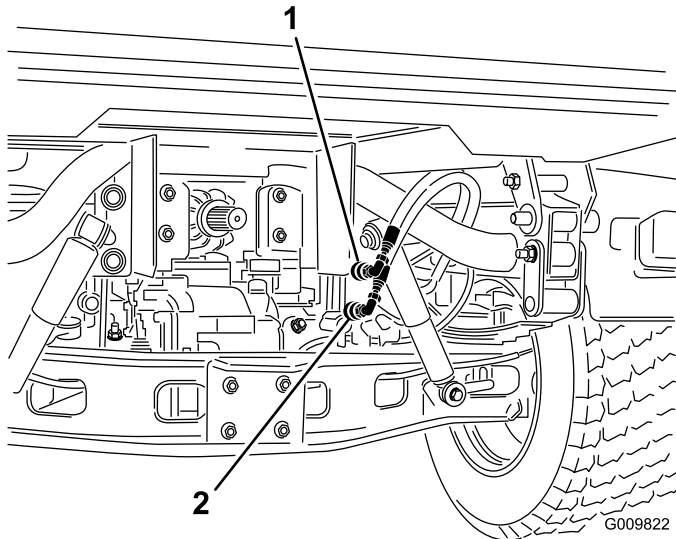

Figure 75

1. Quick-coupler hose A
2. Quick-coupler hose B

3. On the disabled machine, connect the 2 jumper hoses to the hoses that were disconnected (Figure 76).
4. Cap the unused fittings.

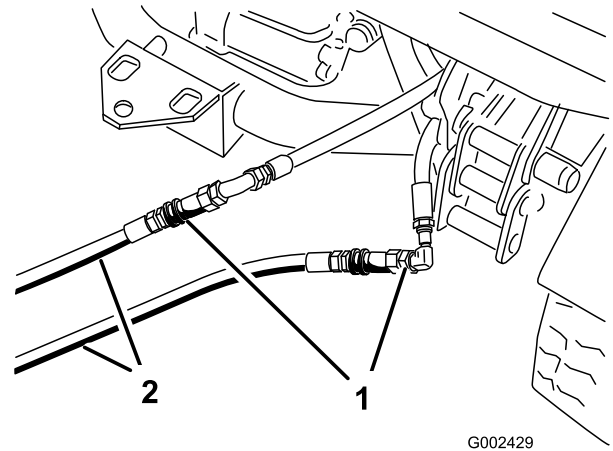

Figure 76

1. Disconnected hoses
2. Jumper hoses

5. On the other machine, connect the 2 hoses to the coupler still in the coupler bracket (connect the top hose to the top coupler and the bottom hose to the bottom coupler) (Figure 77).
6. Cap the unused fittings.

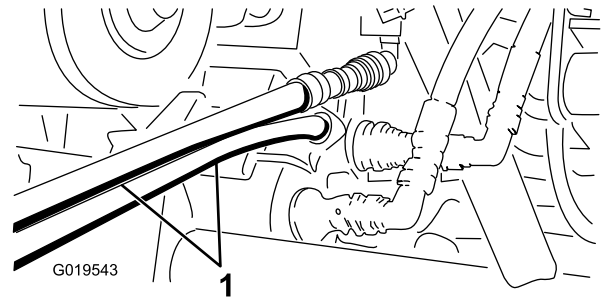

Figure 77

1. Jumper hoses

7. Keep all bystanders away from the machines.
8. Start the second machine, and move the lift lever to the raise position which will raise the disabled cargo box.
9. Move the hydraulic-lift lever to the neutral position, and engage the lift-lever lock.
10. Install the bed support onto the extended lift cylinder; refer to [Using the Bed Support \(page 34\)](#).

**Note:** With both the machine turned off, move the lift lever back and forth to remove the system pressure and ease the disconnection of the quick couplers.

11. After completing the operation, remove the jumper hoses and connect the hydraulic hoses to both machines.

**Important:** Check the hydraulic fluid levels, in both vehicles, before resuming operation.



# Cleaning

## Washing the Machine

The machine should be washed as needed. Use water alone or with a mild detergent. A rag may be used when washing the machine, however the hood will lose some of its luster.

**Important:** Do not use power washing equipment to wash the machine. Power washing equipment may damage the electrical system, loosen important decals, or wash away necessary grease at friction points. Avoid excessive use of water near the control panel, engine, and battery.

**Important:** Do not wash the machine with the engine running. Washing the machine with the engine running may result in internal engine damage.

# Storage

1. Position the machine on a level surface, set the parking brake, stop the engine, and remove the starter key.
2. Clean dirt and grime from the entire machine, including the outside of the engine cylinder head fins and blower housing.  
**Important:** You can wash the machine with mild detergent and water. Do not use high pressure water to wash the machine. Pressure washing may damage the electrical system or wash away necessary grease at friction points. Avoid excessive use of water, especially near the control panel, lights, engine, and the battery.
3. Inspect the brakes; refer to [Checking the Brake-fluid Level \(page 23\)](#).
4. Service the air cleaner; refer to [Servicing the Air Cleaner \(page 40\)](#).
5. Seal the air cleaner inlet and the exhaust outlet with weatherproof tape.
6. Grease the machine; refer to [Greasing the Bearings and Bushings \(page 38\)](#).
7. Change the engine oil; refer to [Changing the Engine Oil and Filter \(page 40\)](#).
8. Flush the fuel tank with fresh, clean diesel fuel.
9. Secure all fuel system fittings.
10. Check the tire pressure; refer to [Checking the Tire Pressure \(page 23\)](#).
11. Check anti freeze protection and add a 50/50 solution of water and anti freeze as needed for expected minimum temperature in your area.
12. Remove the battery from the chassis, check the electrolyte level, and charge it fully; refer to [Servicing the Battery \(page 44\)](#).

**Note:** Do not connect the battery cables to the battery posts during storage.

**Important:** The battery must be fully charged to prevent it from freezing and being damaged at temperatures below 0° C (32° F). A fully charged battery maintains its charge for about 50 days at temperatures lower than 4° C (40° F). If the temperatures will be above 4° C (40° F), check the water level in the battery and charge it every 30 days.

13. Check and tighten all bolts, nuts, and screws. Repair or replace any part that is damaged.
14. Paint all scratched or bare metal surfaces.  
Paint is available from your Authorized Toro Service Dealer.
15. Store the machine in a clean, dry garage or storage area.
16. Cover the machine to protect it and keep it clean.

**Notes:**



**Notes:**

**Notes:**

## International Distributor List

<b>Distributor:</b>	<b>Country:</b>	<b>Phone Number:</b>	<b>Distributor:</b>	<b>Country:</b>	<b>Phone Number:</b>
Agrolanc Kft	Hungary	36 27 539 640	Maquiver S.A.	Colombia	57 1 236 4079
Balama Prima Engineering Equip.	Hong Kong	852 2155 2163	Maruyama Mfg. Co. Inc.	Japan	81 3 3252 2285
B-Ray Corporation	Korea	82 32 551 2076	Mountfield a.s.	Czech Republic	420 255 704 220
Casco Sales Company	Puerto Rico	787 788 8383	Mountfield a.s.	Slovakia	420 255 704 220
Ceres S.A.	Costa Rica	506 239 1138	Munditol S.A.	Argentina	54 11 4 821 9999
CSSC Turf Equipment (pvt) Ltd.	Sri Lanka	94 11 2746100	Norma Garden	Russia	7 495 411 61 20
Cyril Johnston & Co.	Northern Ireland	44 2890 813 121	Oslinger Turf Equipment SA	Ecuador	593 4 239 6970
Cyril Johnston & Co.	Republic of Ireland	44 2890 813 121	Oy Hako Ground and Garden Ab	Finland	358 987 00733
Equivar	Mexico	52 55 539 95444	Parkland Products Ltd.	New Zealand	64 3 34 93760
Femco S.A.	Guatemala	502 442 3277	Perfetto	Poland	48 61 8 208 416
ForGarder OU	Estonia	372 384 6060	Pratoverde SRL.	Italy	39 049 9128 128
G.Y.K. Company Ltd.	Japan	81 726 325 861	Prochaska & Cie	Austria	43 1 278 5100
Geomechaniki of Athens	Greece	30 10 935 0054	RT Cohen 2004 Ltd.	Israel	972 986 17979
Golf international Turizm	Turkey	90 216 336 5993	Riversa	Spain	34 9 52 83 7500
Guandong Golden Star	China	86 20 876 51338	Lely Turfcare	Denmark	45 66 109 200
Hako Ground and Garden	Sweden	46 35 10 0000	Solvret S.A.S.	France	33 1 30 81 77 00
Hako Ground and Garden	Norway	47 22 90 7760	Spypros Stavrinides Limited	Cyprus	357 22 434131
Hayter Limited (U.K.)	United Kingdom	44 1279 723 444	Surge Systems India Limited	India	91 1 292299901
Hydroturf Int. Co Dubai	United Arab Emirates	97 14 347 9479	T-Markt Logistics Ltd.	Hungary	36 26 525 500
Hydroturf Egypt LLC	Egypt	202 519 4308	Toro Australia	Australia	61 3 9580 7355
Irrimac	Portugal	351 21 238 8260	Toro Europe NV	Belgium	32 14 562 960
Irrigation Products Int'l Pvt Ltd.	India	0091 44 2449 4387	Valtech	Morocco	212 5 3766 3636
Jean Heybroek b.v.	Netherlands	31 30 639 4611	Victus Emak	Poland	48 61 823 8369

### European Privacy Notice

#### The Information Toro Collects

Toro Warranty Company (Toro) respects your privacy. In order to process your warranty claim and contact you in the event of a product recall, we ask you to share certain personal information with us, either directly or through your local Toro company or dealer.

The Toro warranty system is hosted on servers located within the United States where privacy law may not provide the same protection as applies in your country.

BY SHARING YOUR PERSONAL INFORMATION WITH US, YOU ARE CONSENTING TO THE PROCESSING OF YOUR PERSONAL INFORMATION AS DESCRIBED IN THIS PRIVACY NOTICE.

#### The Way Toro Uses Information

Toro may use your personal information to process warranty claims, to contact you in the event of a product recall and for any other purpose which we tell you about. Toro may share your information with Toro's affiliates, dealers or other business partners in connection with any of these activities. We will not sell your personal information to any other company. We reserve the right to disclose personal information in order to comply with applicable laws and with requests by the appropriate authorities, to operate our systems properly or for our own protection or that of other users.

#### Retention of your Personal Information

We will keep your personal information as long as we need it for the purposes for which it was originally collected or for other legitimate purposes (such as regulatory compliance), or as required by applicable law.

#### Toro's Commitment to Security of Your Personal Information

We take reasonable precautions in order to protect the security of your personal information. We also take steps to maintain the accuracy and current status of personal information.

#### Access and Correction of your Personal Information

If you would like to review or correct your personal information, please contact us by email at [legal@toro.com](mailto:legal@toro.com).

### Australian Consumer Law

Australian customers will find details relating to the Australian Consumer Law either inside the box or at your local Toro Dealer.



# Toro General Commercial Product Warranty

## A Two-Year Limited Warranty

### Conditions and Products Covered

The Toro Company and its affiliate, Toro Warranty Company, pursuant to an agreement between them, jointly warrant your Toro Commercial product ("Product") to be free from defects in materials or workmanship for two years or 1500 operational hours\*, whichever occurs first. This warranty is applicable to all products with the exception of Aerators (refer to separate warranty statements for these products). Where a warrantable condition exists, we will repair the Product at no cost to you including diagnostics, labor, parts, and transportation. This warranty begins on the date the Product is delivered to the original retail purchaser.

\* Product equipped with an hour meter.

### Instructions for Obtaining Warranty Service

You are responsible for notifying the Commercial Products Distributor or Authorized Commercial Products Dealer from whom you purchased the Product as soon as you believe a warrantable condition exists. If you need help locating a Commercial Products Distributor or Authorized Dealer, or if you have questions regarding your warranty rights or responsibilities, you may contact us at:

Toro Commercial Products Service Department  
Toro Warranty Company  
8111 Lyndale Avenue South  
Bloomington, MN 55420-1196  
952-888-8801 or 800-952-2740  
E-mail: commercial.warranty@toro.com

### Owner Responsibilities

As the Product owner, you are responsible for required maintenance and adjustments stated in your *Operator's Manual*. Failure to perform required maintenance and adjustments can be grounds for disallowing a warranty claim.

### Items and Conditions Not Covered

Not all product failures or malfunctions that occur during the warranty period are defects in materials or workmanship. This warranty does not cover the following:

- Product failures which result from the use of non-Toro replacement parts, or from installation and use of add-on, or modified non-Toro branded accessories and products. A separate warranty may be provided by the manufacturer of these items.
- Product failures which result from failure to perform recommended maintenance and/or adjustments. Failure to properly maintain your Toro product per the Recommended Maintenance listed in the *Operator's Manual* can result in claims for warranty being denied.
- Product failures which result from operating the Product in an abusive, negligent, or reckless manner.
- Parts subject to consumption through use unless found to be defective. Examples of parts which are consumed, or used up, during normal Product operation include, but are not limited to, brake pads and linings, clutch linings, blades, reels, rollers and bearings (sealed or greasable), bed knives, spark plugs, castor wheels and bearings, tires, filters, belts, and certain sprayer components such as diaphragms, nozzles, and check valves, etc.
- Failures caused by outside influence. Conditions considered to be outside influence include, but are not limited to, weather, storage practices, contamination, use of unapproved fuels, coolants, lubricants, additives, fertilizers, water, or chemicals, etc.
- Failure or performance issues due to the use of fuels (e.g. gasoline, diesel, or biodiesel) that do not conform to their respective industry standards.

### Countries Other than the United States or Canada

Customers who have purchased Toro products exported from the United States or Canada should contact their Toro Distributor (Dealer) to obtain guarantee policies for your country, province, or state. If for any reason you are dissatisfied with your Distributor's service or have difficulty obtaining guarantee information, contact the Toro importer.

- Normal noise, vibration, wear and tear, and deterioration.
- Normal "wear and tear" includes, but is not limited to, damage to seats due to wear or abrasion, worn painted surfaces, scratched decals or windows, etc.

### Parts

Parts scheduled for replacement as required maintenance are warranted for the period of time up to the scheduled replacement time for that part. Parts replaced under this warranty are covered for the duration of the original product warranty and become the property of Toro. Toro will make the final decision whether to repair any existing part or assembly or replace it. Toro may use remanufactured parts for warranty repairs.

### Deep Cycle and Lithium-Ion Battery Warranty:

Deep cycle and Lithium-Ion batteries have a specified total number of kilowatt-hours they can deliver during their lifetime. Operating, recharging, and maintenance techniques can extend or reduce total battery life. As the batteries in this product are consumed, the amount of useful work between charging intervals will slowly decrease until the battery is completely worn out. Replacement of worn out batteries, due to normal consumption, is the responsibility of the product owner. Battery replacement may be required during the normal product warranty period at owner's expense. Note: (Lithium-Ion battery only): A Lithium-Ion battery has a part only prorated warranty beginning year 3 through year 5 based on the time in service and kilowatt hours used. Refer to the *Operator's Manual* for additional information.

### Maintenance is at Owner's Expense

Engine tune-up, lubrication, cleaning and polishing, replacement of filters, coolant, and completing recommended maintenance are some of the normal services Toro products require that are at the owner's expense.

### General Conditions

Repair by an Authorized Toro Distributor or Dealer is your sole remedy under this warranty.

**Neither The Toro Company nor Toro Warranty Company is liable for indirect, incidental or consequential damages in connection with the use of the Toro Products covered by this warranty, including any cost or expense of providing substitute equipment or service during reasonable periods of malfunction or non-use pending completion of repairs under this warranty. Except for the Emissions warranty referenced below, if applicable, there is no other express warranty. All implied warranties of merchantability and fitness for use are limited to the duration of this express warranty.**

Some states do not allow exclusions of incidental or consequential damages, or limitations on how long an implied warranty lasts, so the above exclusions and limitations may not apply to you. This warranty gives you specific legal rights, and you may also have other rights which vary from state to state.

### Note regarding engine warranty:

The Emissions Control System on your Product may be covered by a separate warranty meeting requirements established by the U.S. Environmental Protection Agency (EPA) and/or the California Air Resources Board (CARB). The hour limitations set forth above do not apply to the Emissions Control System Warranty. Refer to the Engine Emission Control Warranty Statement supplied with your product or contained in the engine manufacturer's documentation for details