



GROUNDSMASTER[®]
52" Mower
for 120 Traction Unit
Model No. 30753 - 690001

Operator's Manual

IMPORTANT: Read this manual carefully. It contains information about your safety and the safety of others. Also become familiar with the controls and their proper use before you operate the product.

FOREWORD

The 52" cutting deck has advanced concepts in engineering, design and safety; and if maintained properly, will give excellent service.

Since it is a high-quality product, Toro is concerned about the future use of the machine and safety of the user. Therefore, read this manual to familiarize yourself with proper set-up, operation and maintenance instructions. The major sections of the manual are:

- | | | |
|------------------------|---------------------|----------------|
| 1. Safety Instructions | 3. Before Operating | 5. Maintenance |
| 2. Set-up Instructions | 4. Lubrication | |

Certain information in this manual is emphasized. DANGER, WARNING and CAUTION identify personal safety-related information. IMPORTANT identifies mechanical information demanding special attention. Be sure to read this directive because it deals with the possibility of damaging a part or parts of the machine. NOTE identifies general information worthy of special attention.

TABLE OF CONTENTS

	Page		Page
SAFETY INSTRUCTIONS	2-4	Servicing Bushings in Castor Arms	9
SAFETY AND INSTRUCTION DECALS	5	Servicing Castor Wheel and Bearing	10
SPECIFICATIONS	5	Checking for Bent Blade	10
LOOSE PARTS	6	Removing Cutter Blade	10
SET-UP INSTRUCTIONS	6-7	Checking Sail and Sharpening Cutter Blade	11
Install Castor Wheels	6	Correcting Cutting Unit Mismatch	11
Mount Carrier Frame to Traction Frame	6	Replacing Grass Deflector	12
Install Drive Belt	6	Adjusting Idler Pulley	12
Install Rear Weight	7	Replacing Drive Belt	13
BEFORE OPERATING	7	Replacing Spindle Pulley	13
Adjusting Height-of-Cut	7	Removing Spindles and Bearings from Spindle Housing	14
Adjust Gage Wheels	8	Installing Spindle Bearings and Seals in Spindle Housing	14
OPERATING INSTRUCTIONS	8	IDENTIFICATION AND ORDERING	15
Grass Deflector	8	THE TORO PROMISE	16
LUBRICATION MAINTENANCE	8		
Grease Bearings, Bushings, and Gear Case ...	8		
CUTTING UNIT MAINTENANCE	9-15		
Troubleshooting	9		

SAFETY INSTRUCTIONS



The following instructions are comparable to the "Safe Operating Practices for Riding Vehicles" adopted by ANSI — American National Standards Institute B71.4-1990. Although hazard control and accident prevention partially are dependent upon the design and configuration of the machine, these factors are also dependent upon the awareness,

concern, and proper training of the personnel involved in the operation, transport, maintenance, and storage of the machine. Improper use or maintenance of the machine can result in injury or death. To reduce the potential for injury or death, comply with the following safety instructions.

BEFORE OPERATING

1. Read and understand the contents of this Operator's Manual before starting and operating the machine. Become familiar with all controls and how to stop quickly. A replacement manual is available by sending complete Model and Serial Number to:

The Toro Company
8111 Lyndale Avenue South
Bloomington, MN 55420-1196
Attn: Technical Publications

SAFETY INSTRUCTIONS

2. Never allow children to operate the machine. Do not allow adults to operate the machine without proper instruction. Only trained operators who have read this manual should operate this machine.
3. Never operate the machine when under the influence of drugs or alcohol.
4. Remove all debris or other objects that might be picked up and thrown by cutter blades or fast moving components from other attached implements. Keep all bystanders away from the operating area.
5. Do not operate machine without all shields and safety devices in place. If a shield, safety device or decal is damaged, malfunctioning or illegible, repair or replace it before operation is commenced. Also tighten loose nuts, bolts and screws to ensure machine is in safe operating condition.
6. Do not operate machine while wearing sandals, tennis shoes, sneakers or shorts. Also, do not wear loose fitting clothing because it could get caught in moving parts. Always wear long pants and substantial shoes. Wearing safety glasses, safety shoes and a helmet is advisable and required by some local ordinances and insurance regulations.
7. Be sure interlock switches are adjusted correctly so engine cannot be started unless traction pedal is released — neutral position — and PTO switch is in DISENGAGE position.
8. Fill fuel tank with gasoline before starting the engine. Avoid spilling any gasoline. Since gasoline is highly flammable, handle it carefully — DO NOT SMOKE.
 - A. Use an approved gasoline container.
 - B. Do not fill tank while engine is hot or running.
 - C. Do not smoke while handling gasoline.
 - D. Fill fuel tank outdoors and up to about one inch (25 mm) from top of the tank, not the filler neck. KEEP HOOD CLOSED when filling.
 - E. Wipe up any spilled gasoline. Install gasoline container cap and machine fuel tank cap securely before starting the engine.
11. Sit on the seat when starting the engine and operating the machine.
12. When starting the engine:
 - A. Engage parking brake.
 - B. Be sure traction pedal is in neutral and PTO is in disengage position.
 - C. After engine is started, release parking brake and keep foot off traction pedal. Machine must not move. If movement is evident, the neutral return mechanism is adjusted incorrectly; therefore, shut engine off and adjust until machine does not move when traction pedal is released.
13. Using the machine demands attention, and to prevent loss of control:
 - A. Mow only in daylight or when there is good artificial light.
 - B. Watch for holes or other hidden hazards.
 - C. Do not drive close to a sand trap, ditch, creek or other hazard.
 - D. Reduce speed when making sharp turns and when turning on hillsides.
 - E. Avoid sudden stops and starts.
 - F. Before backing up, look to the rear to be sure no one is behind the machine.
 - G. Watch out for traffic when near or crossing roads. Always yield the right-of-way.
14. If engine stalls or machine loses headway and cannot make it to the top of a slope, do not turn machine around. Always back slowly straight down the slope.
15. The grass deflector must always be installed and in lowest position on the side discharge cutting unit. Never operate mower without deflector or entire grass collector in place. This product is designed to drive objects into the ground where they lose energy quickly in grassy areas. However, don't take an injury risk!! When a person or pet appears unexpectedly in or near the mowing area, STOP MOWING. Careless operation, combined with terrain angles, ricochets, or improperly positioned guards, can lead to thrown object injuries. Do not resume mowing until area is cleared.
16. Never raise the cutting unit or other attached implement while the blades or other parts are rotating.
17. If the cutting blades strike a solid object or the machine vibrates abnormally, disengage PTO, move throttle to SLOW, set parking brake and shut engine off. Remove key from switch and disconnect high tension wires from spark plugs to prevent possibility of accidental starting. Check cutting unit and traction unit for damage and

WHILE OPERATING

9. Do not run the engine in a confined area without adequate ventilation. Exhaust fumes are hazardous and could possibly be deadly.
10. Maximum seating capacity is one person. Never carry passengers.

SAFETY INSTRUCTIONS

defective parts. Make all repairs before restarting the engine and operating the cutting unit. Make sure blades are in good condition and blade bolts are tight.

18. Cut grass slopes carefully. When going up-hill or downhill do not start or stop suddenly.

19. Operator must be skilled and trained in how to drive on hillsides. Failure to use caution on slopes or hills may cause loss of control possibly resulting in personal injury or death.

20. Do not touch engine, muffler or its adjacent shroud while engine is running or soon after it is stopped because these areas could be hot enough to cause a burn.

21. Lower the cutting unit or other attached implement to the ground and remove key from switch whenever machine is left unattended.

22. Before getting off the seat:

- A. Move traction pedal to neutral position and remove foot from pedal.
- B. Disengage the PTO and set the parking brake.
- C. Shut the engine off and remove key from ignition switch. Wait for all movement to stop before getting off the seat.

MAINTENANCE

23. Remove key from ignition switch and disconnect high tension wire from spark plug to prevent accidental starting of the engine when servicing, adjusting or storing the machine.

24. Perform only those maintenance instructions described in this manual. If major repairs are ever needed or assistance is desired, contact an Authorized TORO Distributor.

25. To reduce potential fire hazard, keep the engine free of excessive grease, grass, leaves and accumulations of dirt.

26. Be sure machine is in safe operating condition by keeping nuts, bolts and screws tight. Check the blade mounting bolts frequently to be sure they are tight.

27. Make sure all hydraulic line connectors are tight, and all hydraulic hoses and lines are in good condition before applying pressure to the system.

28. Keep body and hands away from pin hole leaks or nozzles that eject hydraulic fluid under high pressure. Use paper or cardboard, not hands, to search for

leaks. Hydraulic fluid escaping under pressure can have sufficient force to penetrate skin and do serious damage. If fluid is ejected into the skin it must be surgically removed within a few hours by a doctor familiar with this form of injury or gangrene may result.

29. Before disconnecting or performing any work on the hydraulic system, all pressure in system must be relieved by stopping engine and lowering implement to the ground.

30. If the engine must be running to perform a maintenance adjustment, keep hands, feet, clothing and other parts of the body away from the cutting unit blades and other moving parts.

31. Do not overspeed the engine by changing governor settings. Maximum engine speed (with engine coupled to transmission) is 3100-3300 rpm. To ensure safety and accuracy, have an Authorized TORO Distributor check maximum engine speed with a tachometer.

32. Engine must be shut off before checking oil or adding oil to the crankcase.

33. At the time of manufacture, the machine conformed to the safety standards in effect. To ensure optimum performance and continued safety conformance of the machine, use genuine TORO replacement parts and accessories. Replacement parts and accessories made by other manufacturers may result in non-conformance with safety standards and could void the warranty.

CAUTION

1. KEEP ALL SHIELDS IN PLACE.
2. BEFORE LEAVING OPERATOR'S POSITION.
 - A. MOVE TRANSMISSION TO NEUTRAL.
 - B. DISENGAGE ATTACHMENT CLUTCH.
 - C. SET PARKING BRAKE.
 - D. LOWER CUTTING UNIT TO GROUND.
 - E. SHUT OFF ENGINE.
 - F. REMOVE IGNITION KEY.
3. WAIT FOR ALL MOVEMENT TO STOP BEFORE SERVICING MACHINE.
4. KEEP BYSTANDERS FROM AREAS BEING MOWED.

SAFETY AND INSTRUCTION DECALS



The following decals are installed on the machine. If any become damaged or illegible, replace it. The decal part number is listed in your parts catalog. Replacement can be ordered from your Authorized Toro Distributor.



ON FRONT OF CUTTING UNIT
(Part No. 66-1340)



ON CENTER OF DECK,
UNDER COVERS
(Part No. 67-5360)



UNDER DEFLECTOR
(Part No. 66-6380)

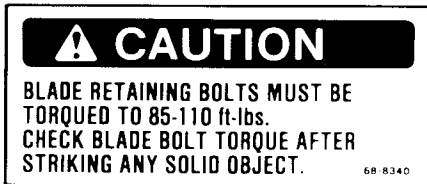

ON REAR OF CUTTING UNIT
(Part No. 68-8340)



ON LEFT SIDE OF
CUTTING UNIT
(Part No. 43-8480)



ON LEFT SIDE OF CUTTING UNIT
(Part No. 68-7260)



ON DISCHARGE CHUTE
(Part No. 54-9220)

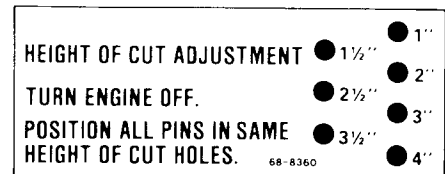

ON LEFT SIDE OF
CUTTING UNIT
(Part No. 68-8360)

SPECIFICATIONS

CUTTING UNIT

Width of Cut: 51-3/4 in. (1.32 m).

Height-of-Cut: Adjustable from 1" to 4" (25 to 102 mm) in 1/2" (13 mm) increments.

Cutter Blades: Three heat treated steel blades, each 3/16 in. (4.8 mm) thick and 18 in. (457 mm) long.

Pneumatic Wheels: 8 in. (203 mm) dia. with greaseable roller bearings. (Inflation 10-15 P.S.I.)

Weight: 200 lb. (91 kg).

Unit Drive System: Belt drive from implement jackshaft to right angle gear box. Belt drive to all spindles.

Optional Equipment: 52" Recycler® Kit Model #59225, Leaf Baffle #68-7210.

LOOSE PARTS

Note: Use this chart as a checklist to assure all parts have been received. Without these parts, total set-up cannot be completed.

DESCRIPTION	QTY.	USE
Capscrews — 3/8-16 x 1-3/4" lg. Locknuts Patch Lock Capscrews—3/8-16 x 7/8" lg. Flatwashers Shims	4 4 4 4 2	Mount carrier frame to traction frame.
Castor Wheel Assembly Thrust Washer Lynch Pin	2 8 2	Install in frame. Install on castor fork shafts. Install in top hole of castor shafts.
V-Belt	1	Mount to cutting unit and traction unit.
Capscrew — 1/2-13 x 1-1/2" Lockwasher — 1/2	2 2	Mount rear weight to frame.
Operator's Manual Registration Card	1 1	

SET-UP INSTRUCTIONS

INSTALL CASTOR WHEELS

1. Place two thrust washers on each castor wheel shaft (Fig. 1).

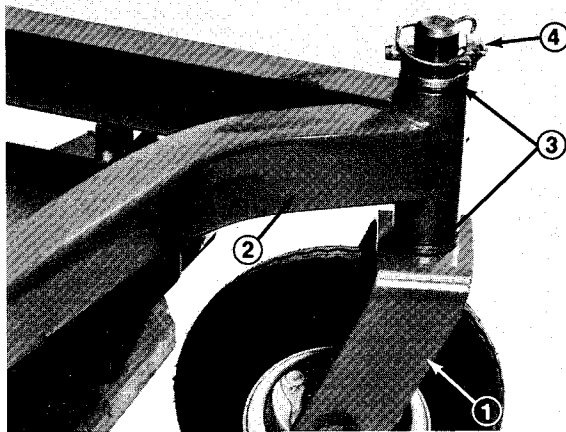

Figure 1

- | | |
|--------------------------|-------------------|
| 1. Castor wheel assembly | 3. Thrust washers |
| 2. Frame | 4. Lynch pin |

2. Insert shafts into carrier frame. Install two more thrust washers and secure with lynch pins (Fig. 1). Grease wheels and carrier shaft bearings.

MOUNT CARRIER FRAME TO TRACTION FRAME

NOTE: Check tire pressure 10-15 psi.

1. Align carrier frame mounting holes with mounting holes in traction frame, while positioning shim on top of traction frame and aligning mounting holes (Fig. 2).

2. Secure each side with (2) 3/8-16 x 1-3/4" lg. capscrews and locknuts. Locknuts must be positioned outside carrier frame.

3. Secure top of each carrier frame and shim to traction frame with (2) 3/8-16 x 7/8" lg. patch lock

capscrews and flatwashers. Torque fasteners to 240-320 in. lb.

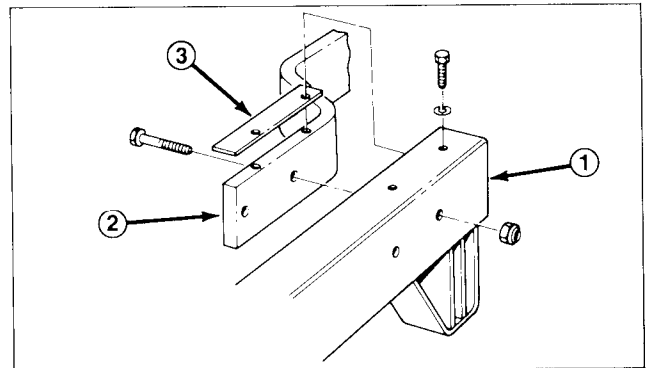

Figure 2

1. Carrier frame 2. Traction frame 3. Shim

INSTALL DRIVE BELT

1. Unhook latch to release center deck cover from housing, and remove cover to expose gear box pulley (Fig. 3).

2. Route V-belt around jackshaft pulley and gear box pulley (Fig. 4).

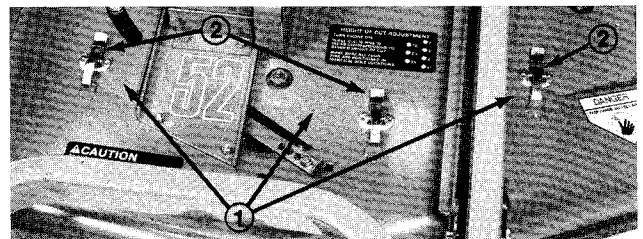

Figure 3

1. Belt covers 2. Cover latches

SET-UP INSTRUCTIONS

3. Raise idler pulley and position over upper portion of belt (Fig. 4).

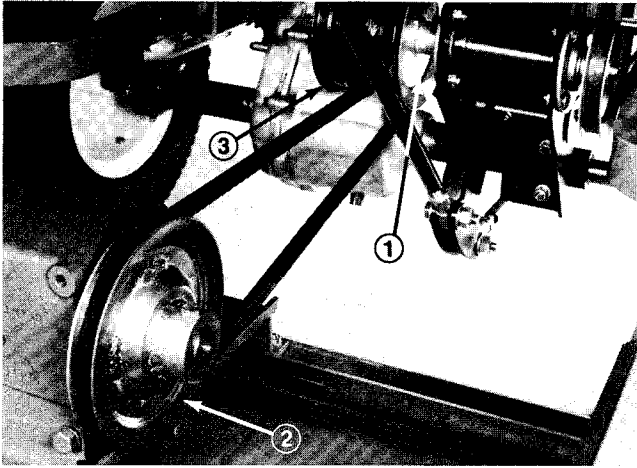

Figure 4

1. Jackshaft pulley 2. Gear box pulley 3. Idler pulley

4. Reinstall belt cover and secure latches to housing.

INSTALL REAR WEIGHT



CAUTION

To insure proper handling and safety characteristics, a 35 lb. rear weight (furnished with traction unit) must be attached.

1. Locate mounting holes under Toro decal in rear frame.
2. Cut away decal material to expose holes.
3. Mount weight to frame with (2) 1/2 - 13 x 1-1/2" lg. capscrews and lockwashers (Fig. 5).

NOTE: Order parts from your Authorized Toro Dealer.

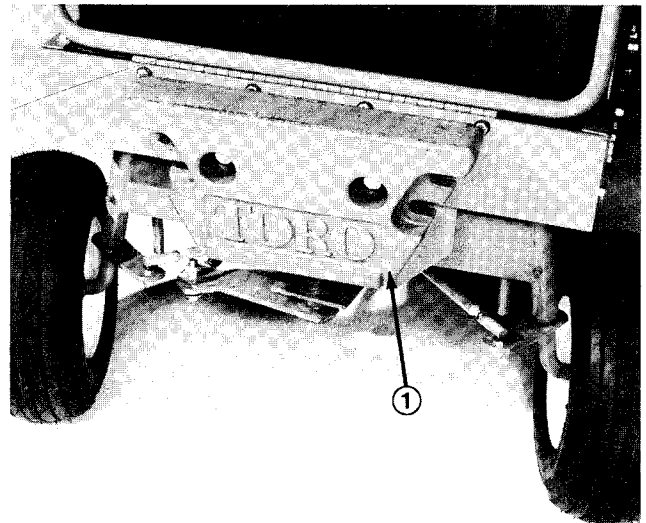

Figure 5

1. Rear weight

BEFORE OPERATING

ADJUSTING HEIGHT-OF-CUT

The height-of-cut is adjustable from 1 to 4 inches (25 to 102 mm) in 1/2 inch (13 mm) increments by relocating four clevis pins in different hole locations in brackets at each corner of the cutting unit (Fig. 6).

Note: All four pins should be in identical hole locations to prevent any operating and cutting difficulties.

Note: If cutting unit is to be used in 1 in. (25 mm) or 1-1/2 in. (38 mm) height-of-cut setting, rear cutting unit rollers must be repositioned in the top bracket holes.

1. Remove cotter pins from roller shafts.
2. Slide shafts out of lower bracket holes, align rollers with top holes and install shafts.
3. Install cotter pins to secure assemblies.

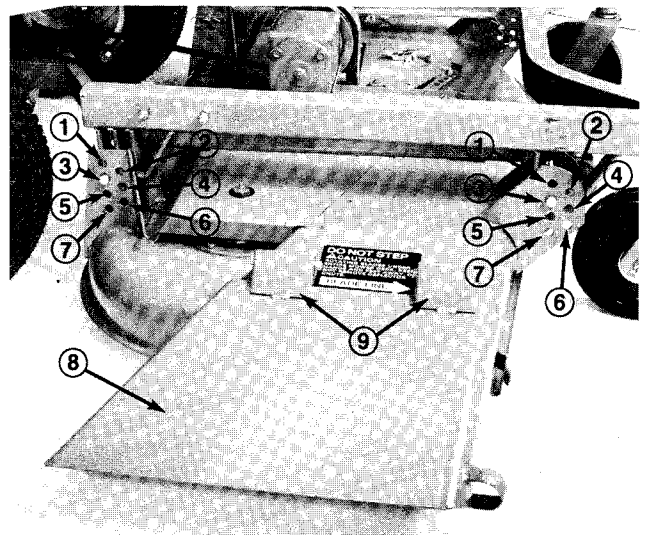

Figure 6

- | | | |
|----------------------|----------------------|--------------------|
| 1. 1 in. (25 mm) | 4. 2-1/2 in. (64 mm) | 7. 4 in. (102 mm) |
| 2. 1-1/2 in. (38 mm) | 5. 3 in. (76 mm) | 8. Grass deflector |
| 3. 2 in. (51 mm) | 6. 3-1/2 in. (89 mm) | 9. Spring hinges |

BEFORE OPERATING

ADJUST GAGE WHEELS

With machine on a flat surface and height-of-cut in desired setting, gage wheels are to be positioned so they are approximately 1/4" to 3/8" above the ground.

IMPORTANT: It is important that gage wheels be adjusted each time height-of-cut is changed, so that the deck will follow the contour of the ground and does not scalp the turf.

1. Remove hairpin cotter and clevis pin securing gage wheel to cutting deck.
2. Move gage wheel up or down to required setting and reinstall clevis pin and cotter pin.
3. Reposition gage wheels each time height-of-cut setting is changed.

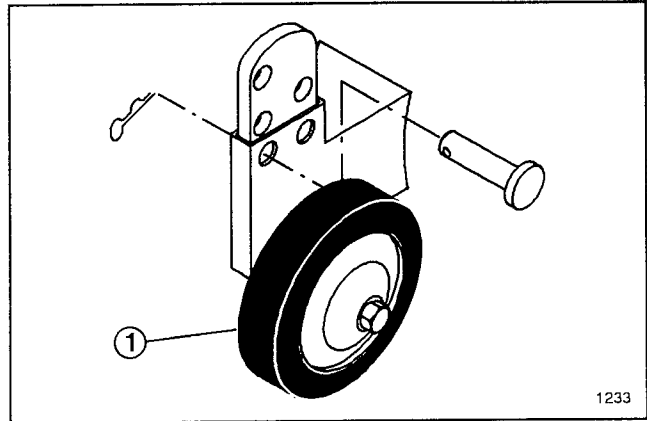

Figure 7
1. Gage wheel

OPERATING INSTRUCTIONS

GRASS DEFLECTOR



CAUTION

The grass deflector (Fig. 6) is a safety device that diverts grass and other foreign objects being discharged downward. Without deflector mounted in place on the cutting unit and spring loaded hinges holding deflector in down position, the blades could hurl grass and foreign objects out the discharge opening with enough force to cause injury or property damage. If the grass deflector or spring hinges are worn, broken or damaged, repair or replace the affected part(s). Never operate cutting unit without deflector or entire grass collector mounted on the cutting unit. Always be sure the deflector chute is in the lowest possible position.

LUBRICATION MAINTENANCE

GREASE BEARINGS, BUSHINGS, AND GEAR CASE

1. The cutting unit must be lubricated regularly. If machine is operated under normal conditions, lubricate castor bearings and bushings with No. 2 general purpose lithium grease or molybdenum base grease, after every 8 hours of operation or daily, whichever comes first. All other bearings, bushings and the gear box must be lubricated after every 50 hours of operation.

2. After every 50 hours of operation, lower cutting unit so castor wheels are on a level surface. Be sure all height-of-cut pins are in the same hole locations. Clean area around gear box filler plug (Fig. 9) to prevent contaminants from entering gear box. Remove filler plug and check level of lubricant. If level of lubricant is low, add SAE E.P. 90 wt. oil until oil level is up to bottom of filler hole. Reinstall filler plug.

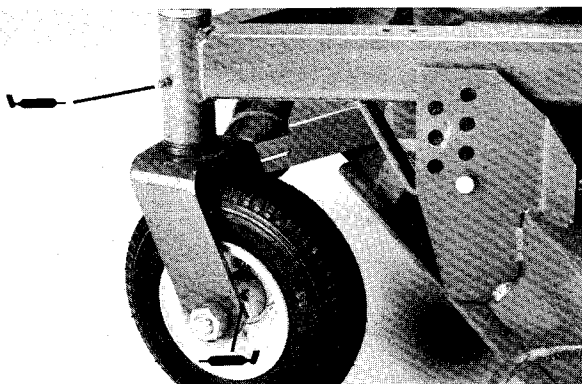

Figure 8

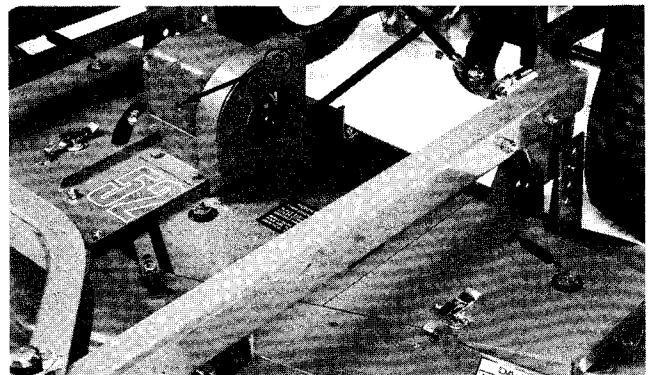
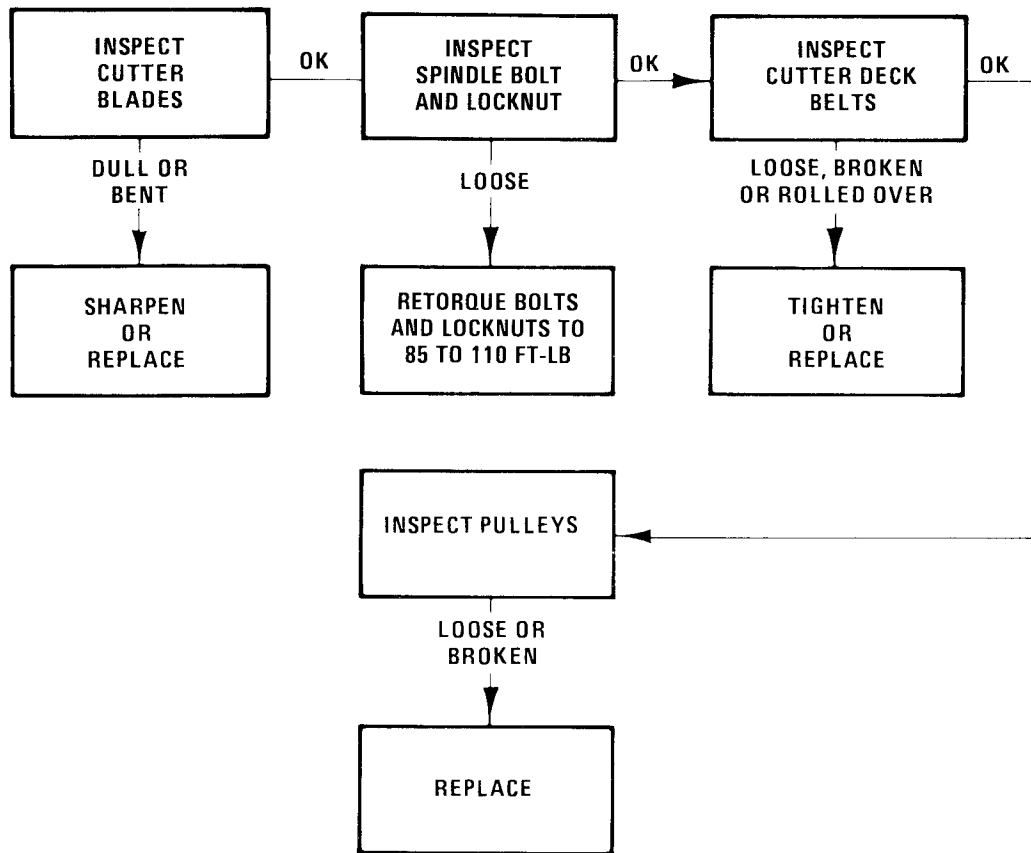

Figure 9
1. Gear box
2. Filler plug

CUTTING UNIT MAINTENANCE TROUBLESHOOTING

UNIT WILL NOT CUT OR CUTS POORLY



CUTTING UNIT MAINTENANCE

SERVICING BUSHINGS IN CASTOR ARMS

The castor arms have bushings pressed into the top and bottom portion of the tube and after many hours of operation, the bushings will wear. To check the bushings, move castor fork back and forth and from side-to-side. If castor spindle is loose inside the bushings, bushings are worn and must be replaced.

1. Raise cutting unit so wheels are off floor and block it so it cannot fall accidentally.
2. Remove lynch pin and thrust washers from top of castor spindle.
3. Pull castor spindle out of mounting tube. Allow thrust washers to remain on bottom of spindle.

4. Insert pin punch into top or bottom of mounting tube and drive bushing out of tube (Fig. 10).

Also drive other bushing out of tube. Clean inside of tubes to remove dirt.

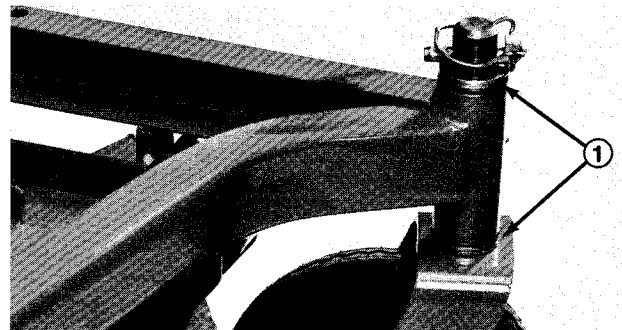

Figure 10
1. Bushings

CUTTING UNIT MAINTENANCE

5. Apply grease to inside and outside of new bushings. Using a hammer and flat plate, drive bushings into mounting tube.
6. Inspect castor spindle for wear and replace it if damaged.
7. Push castor spindle through bushings and mounting tube. Slide spacers onto spindle. Install lynch pin through castor spindle to retain all parts in place.

IMPORTANT: When bushings are installed, the inside diameter may collapse slightly, and this may not allow castor spindle to be installed. If castor spindle does not slide through new bushings and mounting tube, ream both bushings to inside diameter of 1.126 inches (28.6 mm).

SERVICING CASTOR WHEEL AND BEARING

The castor wheel rotates on a high-quality roller bearing and is supported by a spanner bushing. Even after many hours of use, provided that the bearing was kept well-lubricated, bearing wear will be minimal. However, failure to keep bearing lubricated will cause rapid wear. A wobbly castor wheel usually indicates a worn bearing.

1. Remove locknut from capscrew holding castor wheel assembly between castor fork (Fig. 11). Grasp castor wheel and slide capscrew out of fork.

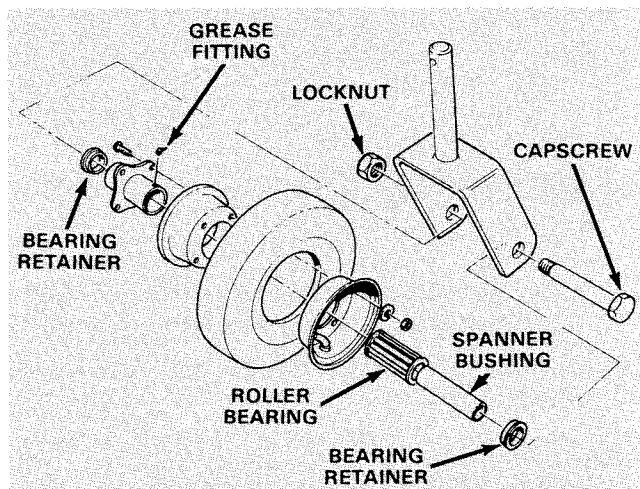

Figure 11

Note: Account for the two bearing retainers (Fig. 11).

2. Tip wheel to the side and allow roller bearing and spanner bushing to fall out (Fig. 11).
3. Inspect bearing, spanner bushing and inside diameter of wheel for wear. Replace defective parts.

4. To reassemble parts, slide spanner bushing through roller bearing. Pack bearing with no. 2 grease; then insert bearing w/spanner bushing into wheel.

5. Slide bearing retainer and thrust washer onto spanner bushing, and mount castor wheel assembly between the fork and capscrew and locknut. Tighten capscrew and locknut until spanner bushing bottoms against inside of castor fork.

6. Pump more grease through grease fitting on wheel (Fig. 11) until bearing is greased thoroughly.

CHECKING FOR BENT BLADE

1. Rotate blade until the ends face forward and backward (Fig. 12). Measure from inside of cutting unit to cutting edge at front of blade (Fig. 12), and remember this dimension.

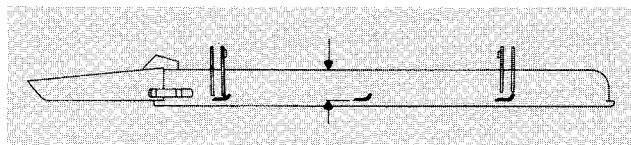

Figure 12

2. Rotate opposite end of blade forward. Measure between the cutting unit and cutting edge of blade at the same position as in step 1. The difference between dimensions obtained in steps 1 and 2 must not exceed 1/8 of an inch (3 mm). If dimension exceeds 1/8 of an inch (3 mm), replace the blade because it is bent: refer to Removing Cutter Blade, page 10.

REMOVING CUTTER BLADE

The blade must be replaced if a solid object is hit, the blade is out-of-balance or if the blade is bent. Always use genuine TORO replacement blades to be sure of safety and optimum performance. Never use replacement blades made by other manufacturers because they could be dangerous.



WARNING

Do not try to straighten a blade that is bent, and never weld a broken or cracked blade. Always use a new blade to assure safety.

1. Grasp end of blade using rag or thickly padded glove. Remove bladebolt, lockwasher, anti-scalp cup and blade from spindle shaft.
2. Install blade — sail facing toward cutting unit with anti-scalp cup, lockwasher and bladebolt. Tighten to 85-110 ft-lb.

CUTTING UNIT MAINTENANCE

CHECKING SAIL AND SHARPENING CUTTER BLADE

Two areas must be considered when checking and servicing the cutter blade: one area is the sail, the other is the cutting edge. Both cutting edges and the sail, which is the turned up metal opposite the cutting edge, contribute to a good quality-of-cut. The sail is important because it pulls grass up straight, thereby producing an even cut. However, the sail will gradually wear down during operation, and this condition is normal. As the sail wears down, the quality-of-cut will degrade somewhat, although the cutting edges are sharp. The cutting edges of the blade must be sharp so the grass is cut rather than torn. A dull cutting edge is evident when tips of the grass appear brown and shredded. Sharpen the cutting edges to correct this condition.

1. Examine cutting ends of the blade carefully, especially where the flat and curved parts of the blade meet (Fig. 13-1). Since sand and abrasive material can wear away the metal that connects the flat and curved parts of the blade, check the blade before using the mower. If wear is noticed (Fig. 13-2), replace the blade.

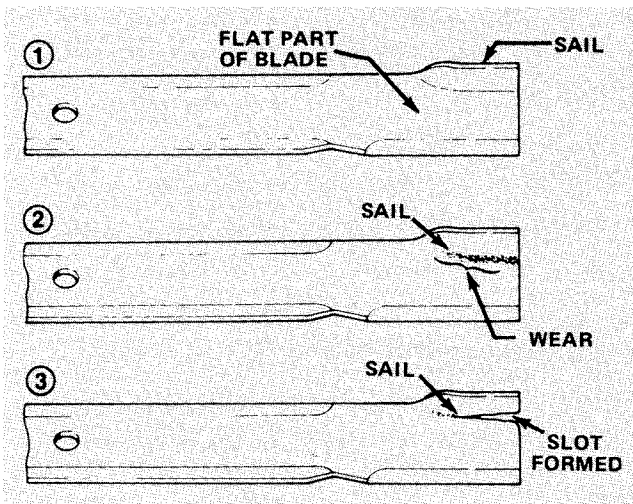

Figure 13



DANGER

If blade is allowed to wear, a slot will form between the sail and flat part of the blade (Fig. 13-3). Eventually a piece of the blade may break off and be thrown from under the housing, possibly resulting in serious injury to yourself or bystander.

2. Inspect cutting edges of all blades. Sharpen the cutting edges if they are dull or nicked. Sharpen only the top of the cutting edge and maintain the original cutting angle to make sure of sharpness (Fig. 14). The blade will remain balanced if same amount of metal is removed from both cutting edges.

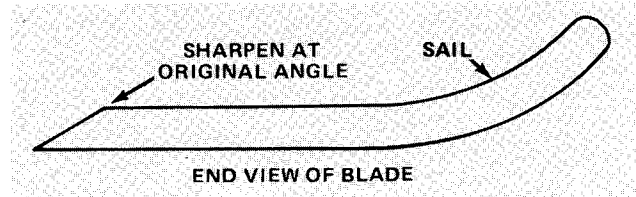

Figure 14

Note: Remove the blades and sharpen them on a grinder: refer to Removing Cutter Blade, page 10. After sharpening the cutting edges, reinstall blade with anti-scalp cup, lockwasher and bladebolt. Blade sails must be on top of blade. Tighten to 85-110 ft-lb.

CORRECTING CUTTING UNIT MISMATCH

If cutting deck does not cut even, check and correct as follows:

1. Park mower on a level surface and engage parking brake. Turn PTO lever OFF, be sure traction pedal is in neutral, turn engine OFF and disconnect spark plug wire(s).
2. Adjust tire pressure in all tires to specifications and check that blade(s) are not bent: refer to Checking for Bent Blade.
3. Place height-of-cut to the 2-1/2 in. position: refer to Adjusting Height-Of-Cut. Make sure height-of-cut pins are resting on frame cushions.
4. Rotate blades so tips line up with one another. Tips of all adjacent blades must be within 1/8 in. of each other. If tips are not within 1/8 in. of each other add shims Part No. 3256-24 between spindle housing and bottom of cutting unit to align blade(s).

Front-to-Rear Pitch

1. Position blade(s) front-to-rear (Fig. 15). Measure at "C" and "D" locations (Fig. 15), from level surface to the cutting edge of blade(s) (Fig. 16).
2. Mower should be 1/8 in. - 5/8 in. lower in front "C" than rear "D".

CUTTING UNIT MAINTENANCE

3. To change front-to-rear pitch move equal number of thrust washers on both front castor shafts. Move thrust washers from top to bottom to raise, or bottom to top to lower pitch (Fig. 17).
4. Check side-to-side level of cutting unit.

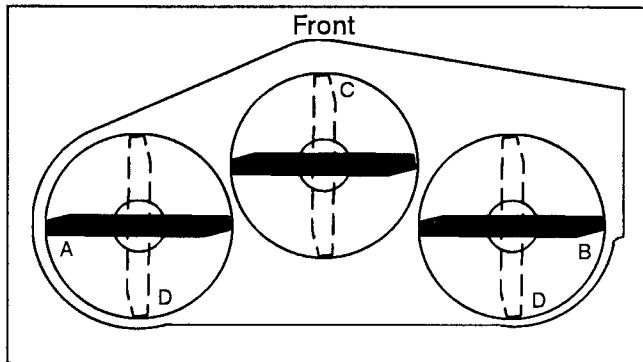

Figure 15

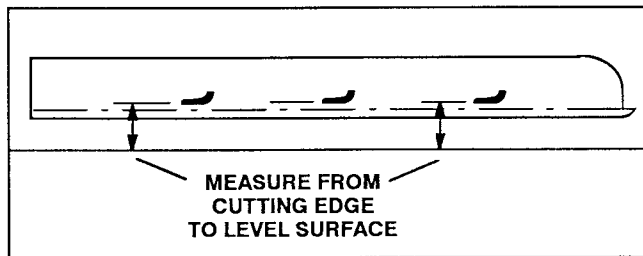

Figure 16

SIDE-TO-SIDE LEVELING

NOTE: Check tire pressure 10-15 psi.

1. Position blade(s) side-to-side (Fig. 15). Measure at "A" and "B" locations (Fig. 15), from level surface to the cutting edge of blade(s) (Fig. 16).
2. The difference between measurements "A" and "B" should be no more than 1/4 in.
3. To change side-to-side leveling move thrust washers on one front castor shaft only. Move thrust washers from top to bottom to raise, or bottom to top to lower (Fig. 17).
4. Re-check front-to-rear pitch of cutting unit.

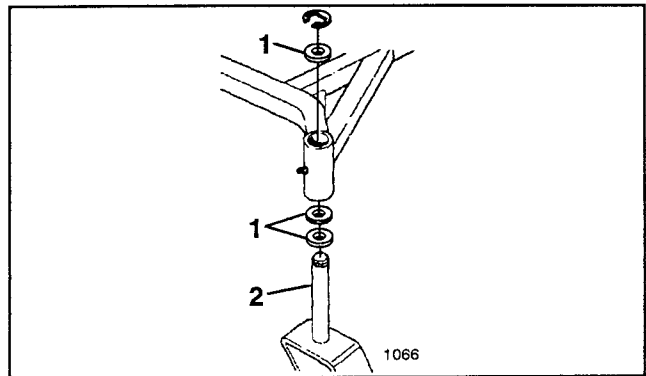

Figure 17

1. Thrust washers (locate as required)
2. Castor shaft

REPLACING GRASS DEFLECTOR

1. Remove two capscrews, locknuts and springs securing deflector mounts to pivot brackets (Fig. 18).

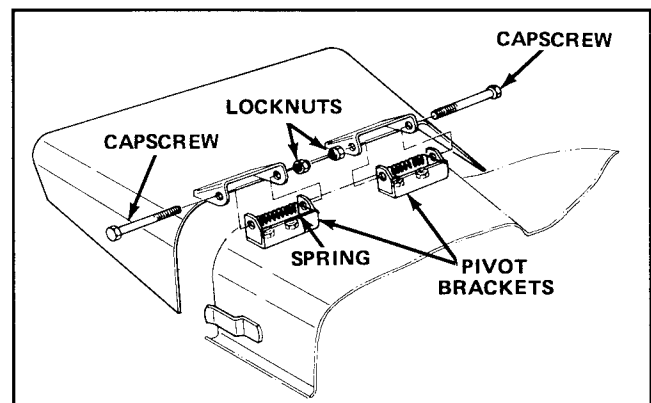

Figure 18

2. To remove the pivot brackets, remove carriage bolts, lockwashers and nuts (Fig. 18).
3. Reinstall pivot brackets on top of discharge opening with carriage bolts, lockwashers and nuts. Head of carriage bolts must be on inside of cutting unit.
4. Position deflector mounts on outside of pivot brackets and secure parts together with capscrews, locknuts and springs. Both locknuts must face each other. Tighten locknuts until they are flush against deflector pivots. Lift deflector and allow it to drop to check spring tension. Deflector must be held firmly in full downward position by spring tension. Correct if necessary.

ADJUSTING IDLER PULLEY

The idler pulley applies force against the belt so power can be transmitted to the blade pulleys. If the idler is not tensioned against the belt with sufficient force,

CUTTING UNIT MAINTENANCE

maximum power will not be transmitted to the pulleys.

1. Release and unhook latches securing belt covers to top of cutting unit. Remove covers.
2. Remove nut securing spring anchor to capscrew in housing (Fig. 19). Lift anchor off capscrew and pull to increase belt tension. Correct belt tension is achieved when approximately 30-40 lbs. of force is applied to spring.

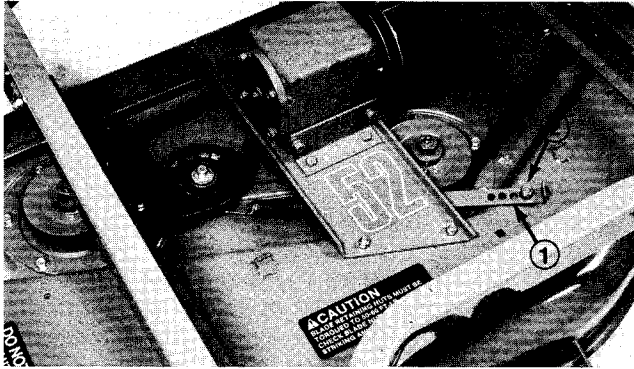

Figure 19

1. Spring anchor
2. Nut

3. Reinstall spring anchor on capscrew in appropriate mounting hole and install nut.

REPLACING DRIVE BELT

The blade drive belt, tensioned by the spring loaded idler, is very durable. After many years of use the belt may show signs of wear. Sign of worn belt are; squeeling when belt is rotating, blade slipping when cutting grass, frayed edges, burn marks and cracks. Replace the belt if any of these conditions are evident.

1. Release latches and remove belt covers.
2. Remove nut securing spring anchor to carscrew in housing (Fig. 19). Remove anchor and allow belt to relax.
3. Loosen gearbox mounting bolts, to provide clearance, and slide belt out through opening between gearbox bracket and deck.
4. Install new belt around spindle, gearbox and idler pullys (Fig. 20) and tighten gearbox mounting bolts.
5. Adjust belt tension; refer to Adjusting Idler Pulley, page 12.
6. Install belt covers.

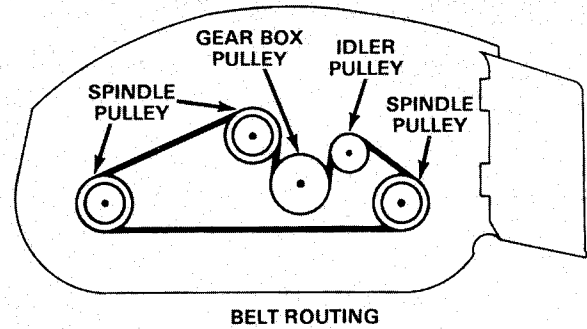

Figure 20

REPLACING SPINDLE PULLEY

1. Remove covers from cutting unit.
2. Remove drive belt, refer to Replacing Drive Belt, page 13.
3. Remove six flange bolts and nuts holding spindle housing assembly and support ring against cutting unit (Fig. 21). Slide spindle housing assembly out bottom of cutting unit.

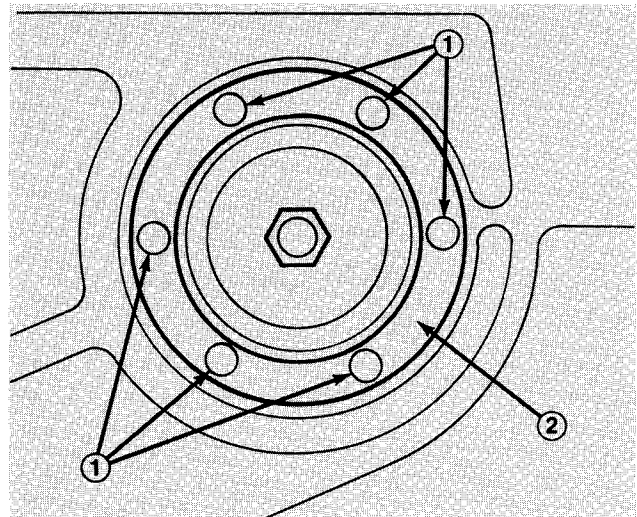

Figure 21

1. Flange bolts
2. Support ring

4. Remove nut retaining pulley on spindle shaft. Pull pulley off shaft.
5. Install new pulley on spindle shaft with locknut. Tighten nut to 50-60 ft. lbs. (68-81 N·m). Use thread lock if nut has been previously removed.
6. Slide pulley end of spindle housing assembly through hole in cutting unit. Mount spindle assembly and support ring in place with six flange bolts and nuts.
7. Install belts and covers.

CUTTING UNIT MAINTENANCE

REMOVING SPINDLES AND BEARINGS FROM SPINDLE HOUSING

1. Remove pulley cover on top of spindle housing to be serviced. Also remove cover over idler pulley.
2. Remove drive belt, refer to Replacing Drive Belt, page 13.
3. Remove six flange bolts and nuts holding spindle housing assembly and support ring against cutting unit (Fig. 21). Slide spindle housing assembly out bottom of cutting unit.
4. Remove nut and flatwasher retaining spindle pulley on spindle shaft. Slide pulley off shaft, which will allow spindle shaft to be removed from spindle housing.
5. If spindle shaft will be replaced, move bladebolt, lockwasher, anti-scalp cup and blade from spindle shaft (Fig. 22). Otherwise, the blade and its other associated parts may be left on the spindle shaft.

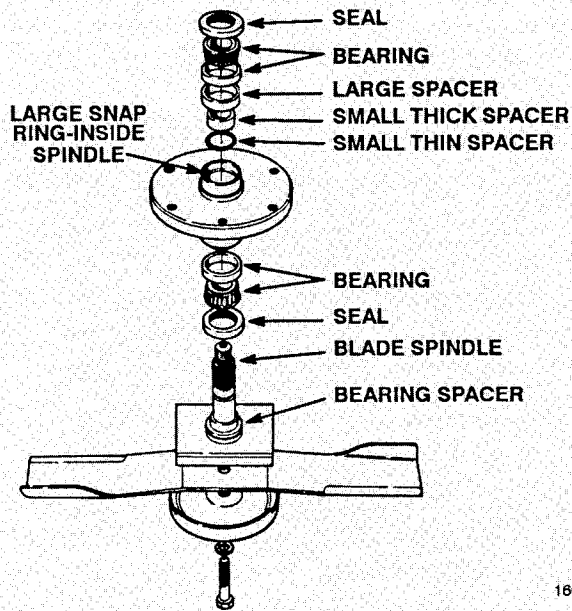

Figure 22

6. Press spindle shaft out of spindle housing (Fig. 22) using an arbor press. Bearing spacer (Fig. 22) remains on spindle shaft as shaft is being removed.
7. The seals (Fig. 22) will be removed next; however, notice the lip of the seal. The lip of the upper seal faces inward, and the lip of the lower seal faces outward. Therefore, new seals must always be installed with the lip facing in the proper direction. Now remove seals from spindle housing.
8. Allow bearings, small thick and small thin spacers to fall out of spindle housing (Fig. 22).

9. Using a punch and hammer, drive both bearing cups (Fig. 22) out of spindle housing. Also drive large spacer (Fig. 22) out of housing.

10. A large snap ring is still inside the spindle housing and it should remain there because it cannot be easily removed.

IMPORTANT: If new bearings will be installed into a used spindle housing that has original snap ring installed, discard the large snap ring that came with the bearings because it is not needed. However, new bearings with matched spacer and snap ring must always be installed when spindle housing is being replaced. Replacement bearings are sold only with a matched snap ring and spacers set. The parts cannot be purchased separately.

INSTALLING SPINDLE, BEARINGS AND SEALS INTO SPINDLE HOUSING

IMPORTANT: If a new spindle housing is being used, new bearings and the matched snap ring set must be installed: refer to step 1. Never use old bearings, spacer and snap ring with a new spindle housing. By contrast, use only new bearings w/cups and spacer — not large snap ring because it is not required — when installing bearings into a used spindle housing that still has snap ring installed: refer to step 2.

1. Install large snap ring into groove in bore of spindle housing (Fig. 23). Assure snap ring is seated in the groove.

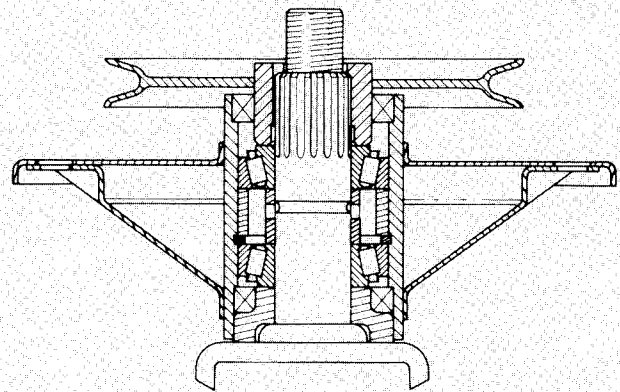

Figure 23

2. Using an arbor press, push the large spacer into top of spindle housing and tightly against the snap ring (Fig. 22). Spacer must contact snap ring to be sure of correct assembly of parts (Fig. 23).
3. Thoroughly oil cups and using an arbor press, push bearing cups — smallest ID first — into top and bottom of spindle housing (Fig. 22). Top bearing cup must contact spacer that was installed in step 2, and

CUTTING UNIT MAINTENANCE

bottom bearing cup must contact snap ring to be sure of correct assembly of parts (Fig. 23). Insure assembly is correct by supporting the first cup and pressing the second against it (Fig. 24).

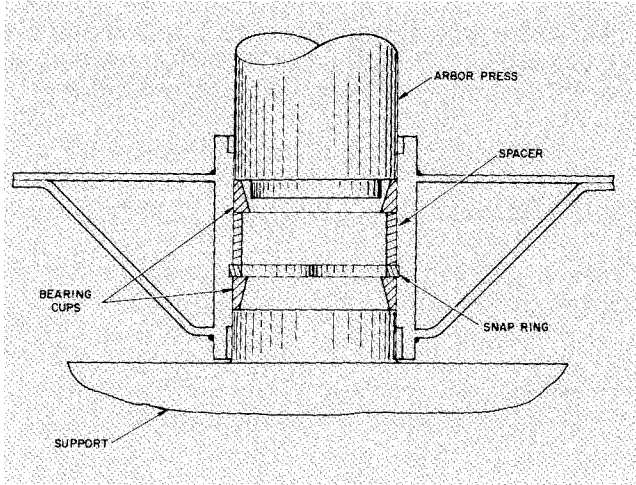

Figure 24

4. Apply a film of grease on lip of both seals; then install bearing and seal into bottom of spindle housing (Fig. 23). Remember though, the bottom seal must have the lip facing outward (Fig. 22) not toward inside of spindle housing.

5. Slide small thick and small thin spacers into spindle housing (Fig. 22). Then, install bearing and seal into top of spindle housing. Lip of the seal must face outward.

6. Check spindle shaft, make sure it is free of burrs and nicks that could possibly cut the seals, thoroughly lubricate shaft and seal lips.

7. Slide bearing spacer onto spindle shaft. Carefully slide spindle shaft through spindle housing. Bottom seal and gearing spacer fit together when spindle is installed (Fig. 23).

8. Push pulley onto splines of spindle shaft, and retain parts together with large flat washer and nut. Tighten nut to 100-102 ft. lbs. (136-163 N·m) and rotate spindle shaft to be sure shaft rotates freely. Use thread lock if nut has been previously removed. Replace nut after removing and installing 4 times.

9. Slide pulley end of spindle assembly through hole in cutting unit. Mount spindle assembly in place with support ring and six carriage bolts and flange nuts (Fig. 21).

10. Install belts and covers.

11. Grease spindle bearings (approximately 2-3 oz.).

IDENTIFICATION AND ORDERING

MODEL AND SERIAL NUMBERS

The cutting unit has two identification numbers: a model number and a serial number. These numbers are stamped into a plate. The cutting unit identification plate is located behind the right front caster wheel on carrier frame (Fig. 25). In any correspondence concerning the cutting unit, supply the model and serial numbers to assure correct information and replacement parts are obtained.

To order replacement parts from an authorized TORO Distributor, supply the following information:

1. Model and serial numbers of the cutting unit.
2. Part number, description and quantity of parts desired.

Note: Do not order by reference number if a parts catalog is being used; use the part number.

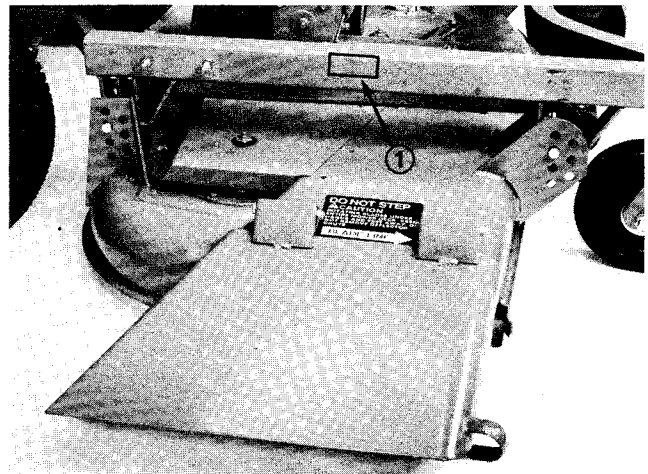

Figure 25

1. Model and serial number

TOROProLine
Products**THE TORO TOTAL COVERAGE
GUARANTEE****A One Year Limited Warranty
(A Full Two-Year Warranty for Residential Use)****What Is Covered By This Express Warranty?**

The Toro Company promises to repair any TORO ProLine product used for commercial, institutional, or rental purposes if defective in materials or workmanship for a period of one year from the date of purchase. The cost of parts and labor are included as well as transportation within a 15 mile radius of a TORO ProLine Service Dealer.

What Products Are Covered By This Warranty?

ProLine products covered by this warranty include the ProLine 118, 120, 220, 616, 620, 724 riding products and wide area walk behind mowers and their cutting decks and accessories.

How About Residential Use?

TORO ProLine products used for residential use are covered by a full two-year warranty.

How Do You Get Warranty Service?

Should you feel your TORO ProLine product contains a defect in materials or workmanship, contact the dealer who sold you the product or any TORO ProLine Service Dealer. The Yellow Pages of your telephone directory is a good reference source; look under TORO Commercial Service Dealers. The Service Dealer will either arrange service at his/her dealership or recommend another authorized Service Dealer who may be more convenient. You may need proof of purchase (copy of registration card, sales receipt, etc.) for warranty validation.

If for any reason you are dissatisfied with a Service Dealer's analysis of the defect in materials or workmanship or if you need a referral to a TORO ProLine Service Dealer, please feel free to contact us at the following address:

Toro Customer Service Department
8111 Lyndale Avenue South
Bloomington, MN 55420-1196
612-888-8801

What Must You Do To Keep The Warranty In Effect?

You must maintain your TORO Product by following the maintenance procedures described in the operator's manual. Such routine maintenance, whether performed by a dealer or by you, is at your expense.

**What Does This Warranty Not Cover?
and****How Does Your State Law Relate To This Warranty?**

There is no other express warranty except as described above. This express warranty does not cover:

- Cost of regular maintenance service or parts, such as filters, fuel, lubricants, tune-up parts, blade sharpening, brake and clutch adjustments.
- Any product or part which has been altered or misused or required replacement or repair due to normal wear, accidents, or lack of proper maintenance.
- Repairs necessary due to improper fuel, contaminants in the fuel system, or failure to properly prepare the fuel system prior to any period of non-use over three months.
- Pickup and delivery charges for distances beyond a 15 mile radius from a TORO ProLine Service Dealer.

All repairs covered by this warranty must be performed by a TORO Service Dealer using Toro approved replacement parts.

Repair by a TORO Service Dealer is your sole remedy under this warranty.

The Toro Company is not liable for indirect, incidental or consequential damages in connection with the use of the TORO Products covered by this warranty, including any cost or expense of providing substitute equipment or service during reasonable periods of malfunction or non-use pending completion of repairs under this warranty. Some states do not allow exclusions of incidental or consequential damages, so the above exclusion may not apply to you.

This warranty gives you specific legal rights, and you may also have other rights which vary from state to state.

COUNTRIES OTHER THAN THE UNITED STATES OR CANADA

Customers who have purchased TORO products exported from the United States or Canada should contact their TORO Distributor (Dealer) to obtain guarantee policies for your country, province, or state. If for any reason you are dissatisfied with your Distributor's service or have difficulty obtaining guarantee information, contact the TORO importer. If all other remedies fail, you may contact us at The Toro Company.