



Wheel Horse®
36" Tiller
for
Classic Garden Tractors
Model No. 79370 – 6900001 & Up

Operator's Manual

IMPORTANT: Read this manual carefully. It contains information about your safety and the safety of others. Also become familiar with the controls and their proper use before you operate the product.

Introduction

We want you to be completely satisfied with your new product, so feel free to contact your local Authorized Service Dealer for help with service, genuine replacement parts, or other information you may require.

Whenever you contact your Authorized Service Dealer or the factory, always know the model and serial numbers of your product. These numbers will help the Service Dealer or Service Representative provide exact information about your specific product. You will find the model and serial number plate located in a unique place on the product as shown below.

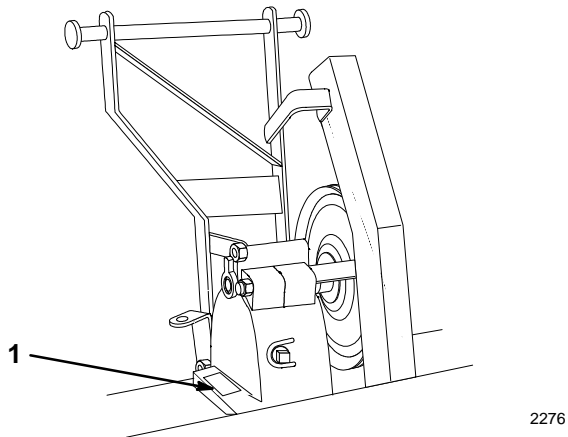

1. Model and Serial Number Plate

For your convenience, write the product model and serial numbers in the space below.

Model No: _____
Serial No. _____

The warning system in this manual identifies potential hazards and has special safety messages that help you and others avoid personal injury, even death. DANGER, WARNING and CAUTION are signal words used to identify the level of hazard. However, regardless of the hazard, be extremely careful.

DANGER signals an extreme hazard that will cause serious injury or death if the recommended precautions are not followed.

WARNING signals a hazard that may cause serious injury or death if the recommended precautions are not followed.

CAUTION signals a hazard that may cause minor or moderate injury if the recommended precautions are not followed.

Two other words are also used to highlight information. “Important” calls attention to special mechanical information and “Note” emphasizes general information worthy of special attention.

The left and right side of the machine is determined by sitting on the seat in the normal operator’s position.

Contents

	Page		Page
Safety and Instruction Decals	2	Attachment Power Lift	15
Installation	3	Adjusting Dial-A-Height	16
Loose Parts	3	Adjusting Lift Chain	16
Assemble Tiller	5	Tips for Tilling	17
Tractor Set-Up	6	Maintenance	18
Installing Tiller to Tractor	9	Service Interval Chart	18
Removing the Tiller	12	Greasing and Lubrication	19
Operation	14	Adjusting Drive Belt Tension	19
Operating the Power Take Off (PTO)	14	Storage	20
Attachment Lift Lever	15		

Safety and Instruction Decals



Safety decals and instructions are easily visible to the operator and are located near any area of potential danger. Replace any decal that is damaged or lost.

**ON TINE SHIELD
LEFT and RIGHT SIDE
(Part No. 92-7112)**

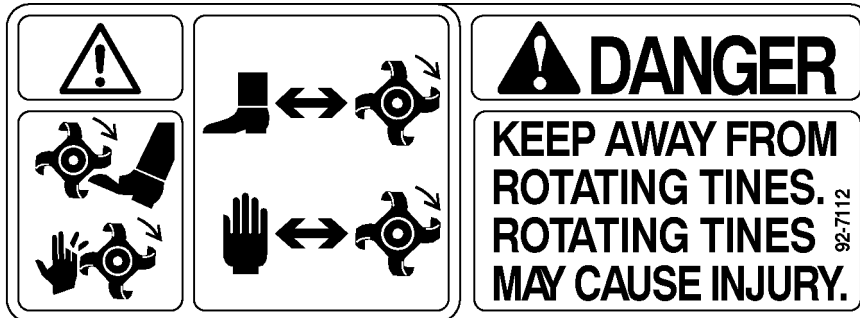

Installation

Loose Parts

Note: Use the chart below to identify parts for assembly.

DESCRIPTION	QTY.	USE
Hitch	1	Install tiller hitch to tiller gear case.
Spring bracket	1	
Bolt (installed in case for shipping) 3/8 x 5-1/2"	2	
Nut (installed in case for shipping) 3/8"	2	
Pulley	1	Install drive pulley to tiller gear case.
Key	1	
Set screw 15/16"	1	
Idler pulley	1	Install idler pulley and belt guard.
Spacer	1	
Belt guide	1	
Belt guard	1	
Bolt 3/8-16 x 2-1/4"	1	
Lock nut 3/8"	1	
Rear shield	1	Install rear shield to tiller.
Cotter pin 1"	3	
Lift chain	1	Install lift chain to tiller.
Clevis	1	
Clevis pin	1	
Cotter pin 3/4"	1	
Tube-Hydro\Gear	2	Install lift cable to tractor.
Clamp	1	
Cable	1	
Clevis-Short\Long	2	
Clevis pin	1	
Cotter pin 1"	2	
Trunnion	1	
Washer 5/8"	1	

DESCRIPTION	QTY.	USE
Lift lever	1	Install lift lever to tractor.
Bushing	2	
Shim washer	4	
E-ring	2	
Latching plate	1	Assemble mounting plate.
Latch lever	2	
Carriage bolt 3/8–16 x 1”	2	
Washer 3/8”	2	
Lock nut 3/8”	2	
Clevis pin	2	
Cotter pin 3/4”	2	
Latch plate assembly	1	Install mounting plate to tractor.
Link bracket-right	1	
Link bracket-left	1	
Angle spacer (if required)	1	
Carriage bolt 3/8–16 x 3-1/2”	4	
Lock nut 3/8”	4	
Spring-large	1	Install lift assist spring to tiller.
Eye bolt	1	
Lock nut 3/8”	1	
Mid-mount bracket assembly	1	Install idler pulley assembly to tractor.
Belt	1	
Bolt 3/8–16 x 2-3/4”	1	
Bolt 3/8–16 x 1-3/4”	1	
Washer 3/8”	1	
Lock nut 3/8”	3	
Spring-small	1	
Belt guard	1	
Bolt-self tapping 1/4 x 1/2”	2	

Assemble Tiller

1. Tip tiller onto back and support in an upright position. Remove $3/8 \times 5-1/2$ " and $3/8 \times 4-1/2$ " bolts. (Fig. 1). Discard extra nuts used as spacers for shipping.
2. Fasten hitch and spring bracket with bolts and nuts as shown in (Fig. 1). Tighten bolts securely.
3. Install pulley with hub $1/4$ " in from the end of drive shaft (Fig. 1). Secure with square key and (2) $5/16$ " square head set screws.

IMPORTANT: Key must be located under a set screw to be retained.

4. Assemble idler and belt guide into lower hole of belt guard and install onto hitch through upper hole with $3/8 \times 2-1/4$ " bolt and $3/8$ " lock nut (Fig. 1).

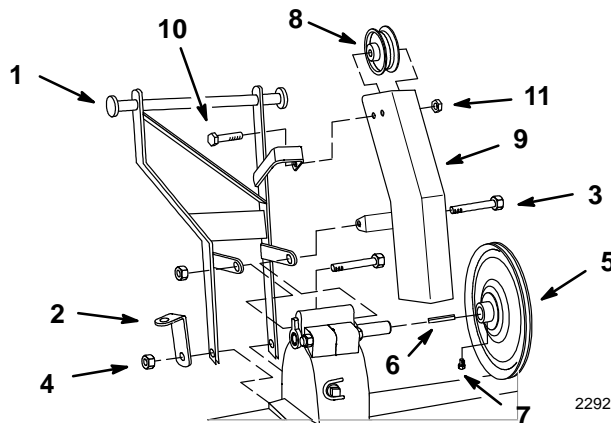

Figure 1

- | | |
|--------------------------|----------------------------------|
| 1. Hitch | 7. Set screw $5/16$ " |
| 2. Spring bracket | 8. Idler |
| 3. Bolt (in tiller case) | 9. Belt cover |
| 4. Nut (on tiller bolt) | 10. Bolt $3/8-16 \times 2-1/4$ " |
| 5. Pulley | 11. Lock nut $3/8$ " |
| 6. Key | |

5. Rotate tiller down and hook rear shield into slots at rear of tine shield. Secure with (3) 1" cotter pins (Fig. 2).

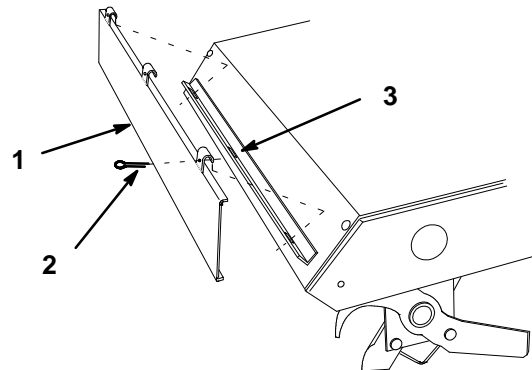

Figure 2

- | | |
|------------------|---------|
| 1. Rear shield | 3. Slot |
| 2. Cotter pin 1" | |

6. Attach lift chain, short link end, one link short, to lift bracket with clevis, clevis pin and secure with $3/4$ " cotter pin (Fig. 3).

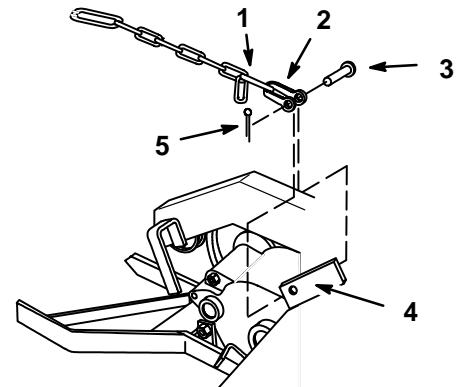

Figure 3

- | | |
|---------------|-----------------------|
| 1. Short link | 4. Bracket |
| 2. Clevis | 5. Cotter pin $3/4$ " |
| 3. Clevis pin | |

Tractor Set-Up

1. Remove and save carriage bolts at fender mount under the seat and attaching footrests. (Fig. 4).

2. Unplug seat wiring harness connector and remove wire harness from wire clip.

Note: If tractor has a 25 amp fuse clipped inside console, remove the fuse.

3. Remove the fender\seat pan from the tractor.

Note: Save all hardware for use when re-installing fenders.

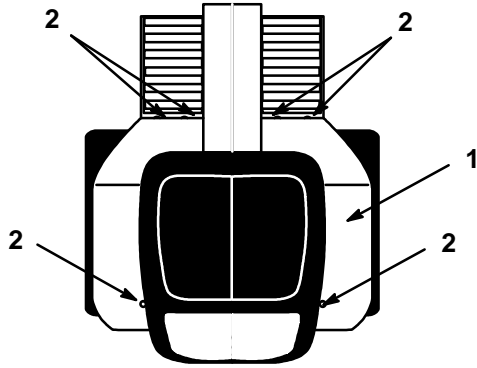
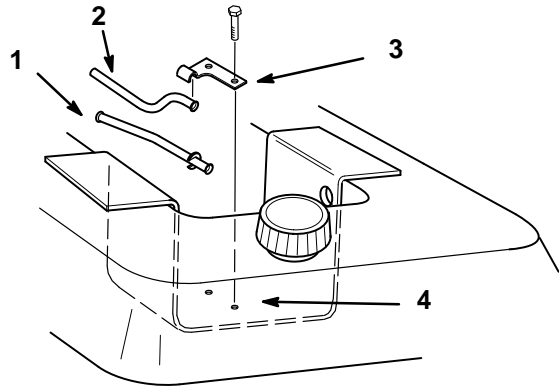

Figure 4

1. Fender\seat pan 2. Carriage bolt

4. Remove bolts and lock washers securing fuel tank bracket to the top of transmission.

5. Select proper cable tube (straight for gear drive, bent for hydrostatic) and install on the top of fuel tank bracket. Secure to fuel tank bracket with clamp and previously removed lock washers and bolts.



2293

Figure 5

1. Cable tube-gear drive 3. Clamp
2. Cable tube-hydrostatic 4. Bracket

- Slide a shim washer and bushing onto ends of lift lever rod (Fig. 6).

IMPORTANT: Check that bushings slide easily onto rod ends and into frame. Remove paint if necessary.

- Position lift lever into frame and slide bushings and shim washers outward into frame holes. Secure in position with E-rings (Fig. 6).

IMPORTANT: Lift lever must not have excessive end play (more than .015 inch). Use extra shim washers (.015 and .020 thick) to reduce end play.

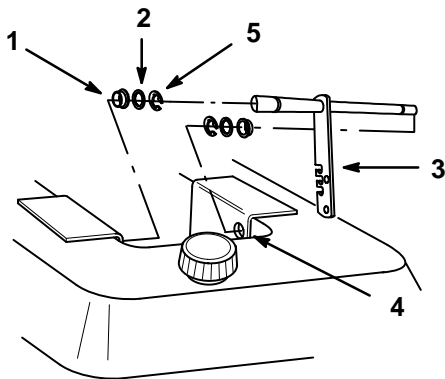

2291

Figure 6

- | | |
|------------------------------|---------------|
| 1. Bushing | 3. Lift lever |
| 2. Shim Washer (as required) | 4. Frame hole |
| | 5. E-ring |

- Slide ball end of attachment lift cable through cable tube from the rear.

- Select correct clevis as follows:

2" long clevis: for 8-speed gear drive and hydrostatic models with oil filter on right side.

3-1/8" long clevis: for hydrostatic models with oil filter facing rear.

- Lower attachment lift and place cable, ball end, into slot in clevis (Fig. 7). Attach clevis to hole in attachment lift and secure with clevis pin and 1" cotter pin (Fig. 7).

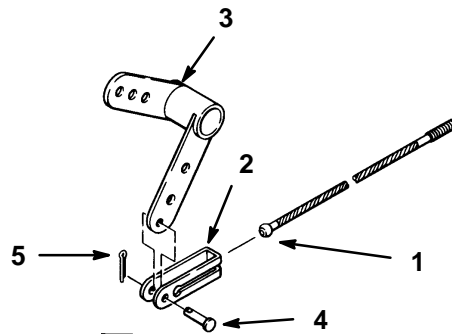

2315

Figure 7

- | | |
|--------------------------------|------------------|
| 1. Lift cable knob | 4. Clevis pin |
| 2. Clevis (select proper size) | 5. Cotter pin 1" |
| 3. Attachment lift | |

Note: If tractor has a 25 amp fuse clipped inside console, install the fuse.

11. Thread trunnion 1" into end of lift cable threaded end and insert into lower hole of lift lever. Secure with 5/8" washer and hairpin cotter (Fig. 8).

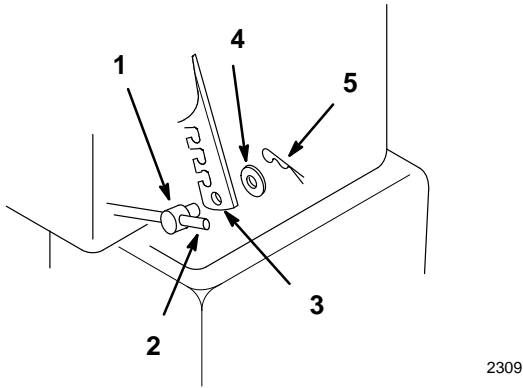

Figure 8

- | | |
|-----------------------------|-------------------|
| 1. Trunnion | 4. Washer 5/8" |
| 2. Lift cable threaded end | 5. Hairpin cotter |
| 3. Lower hole in lift lever | |

12. Install fenders and seat with previously removed hardware.

13. Plug seat wiring harness connector and insert wire harness into wire clip.

14. Install latch levers to mounting plate with 3/8 x 1" carriage bolts, 3/8" washers and 3/8" lock nuts (Fig. 9).

Note: Tighten nuts so latch levers move, but hold in position for ease of tiller mounting to tractor.

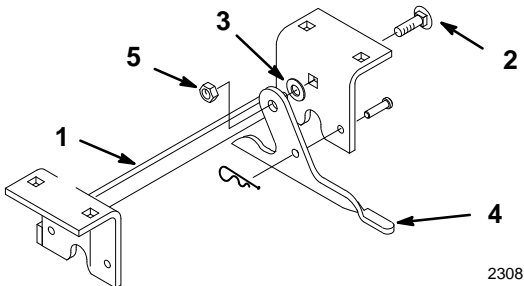

Figure 9

- | | |
|---------------------------|------------------|
| 1. Mounting plate | 4. Latch lever |
| 2. Carriage bolt 3/8 x 1" | 5. Lock nut 3/8" |
| 3. Washer 3/8" | |

15. Center hitch on axle housing and install with (4) 3/8 x 3-3/4" carriage bolts, left side angle plate (with hole rearward), right side strap and 3/8" lock nut as shown (Fig. 10).

Note: On hydrostatic models with oil filter facing rear locate hitch 3-1/4" (8.3 cm) from right side of center housing.

Note: To tighten hitch mounting, install angle spacers, positioned along top and rear of axle, on 8-speed gear drive and hydrostatic models with oil filter on right side.

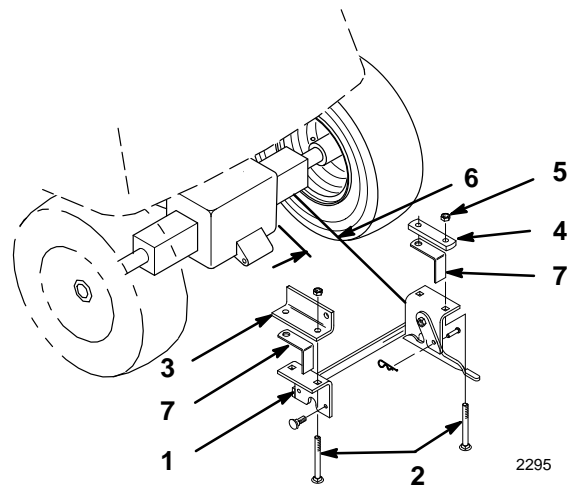

Figure 10

- | | |
|-------------------------------|-----------------------------|
| 1. Mounting plate | 5. Lock nut 3/8" |
| 2. Carriage bolt 3/8 x 3-3/4" | 6. 3-1/4" (8.3 cm) location |
| 3. Angle plate-left side | 7. Angle spacer-if required |
| 4. Strap-right side | |

16. Check mounting location of idler arm in hole of idler bracket (Fig. 11). Correct location is as follows:

Front hole for 400 & 500 Series Twin cylinder tractors and all Single cylinder tractors.

Rear hole for C & GT Series Twin cylinder tractors.

17. If necessary, remove 3/8" lock nut (Fig. 11) and change idler arm hole location. Secure with same lock nut.

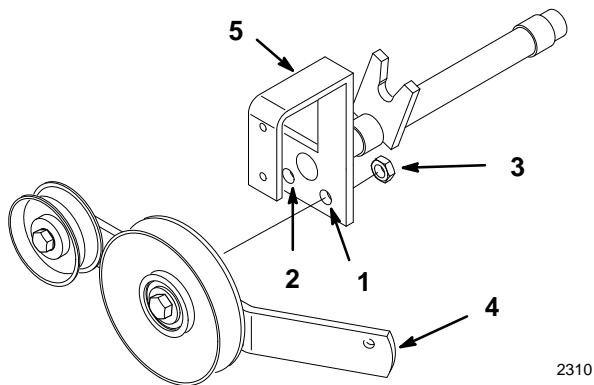

Figure 11

- | | |
|------------------|-----------------------|
| 1. Front hole | 4. Idler arm assembly |
| 2. Rear hole | 5. Idler bracket |
| 3. Lock nut 3/8" | |

Installing Tiller to Tractor

1. Remove snap ring from pin and slide from drawbar and spacers. Remove hitch from tractor (Fig.).

Note: Save all hardware for use when re-installing hitch.

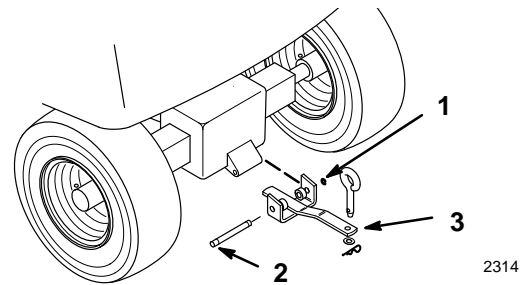

Figure 12

- | | |
|--------------|------------|
| 1. Snap ring | 3. Drawbar |
| 2. Pin | 4. Spacer |

1. Park the machine on a level surface, disengage the power take off (PTO), set the parking brake, and turn the ignition key to "OFF" to stop the engine. Remove the key.
2. Position tiller behind and under rear tractor hitch with idler pulley bracket above right latch lever. Lift latch levers and install frame mounting rod. Center tiller between hitch latches (Fig. 13).
3. Secure latch levers closed with clevis pins and hairpin cotters (Fig. 13).

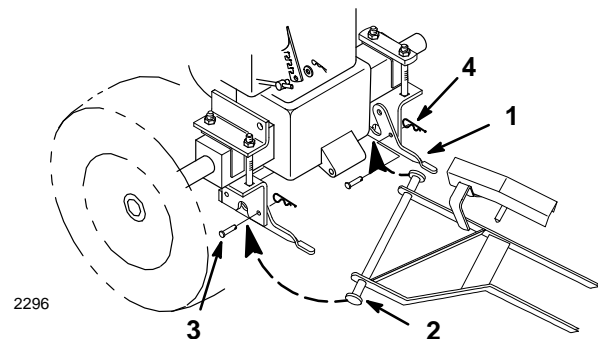
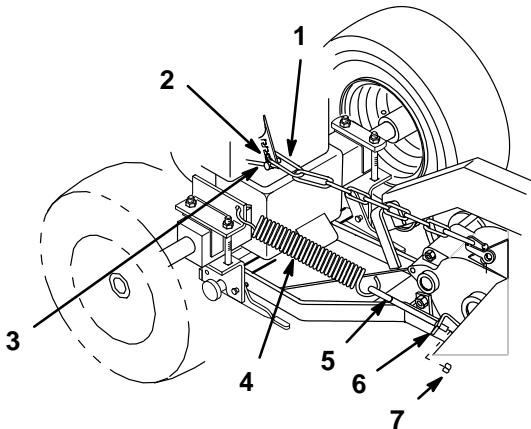

Figure 13

- | | |
|-----------------|-------------------|
| 1. Latch lever | 3. Clevis pin |
| 2. Mounting rod | 4. Hairpin cotter |

4. Set Dial-a-Height to the Mounting Position, and lower attachment lift all the way; refer to Setting Height-of-Cut.
5. Remove trunnion and slide long link of lift chain under attachment lift arm and hook into lower notch (Fig. 14). Install trunnion into bottom hole of lift lever.
6. Raise attachment lift lever to the transport position and place a block under tiller gear case.
7. Hook lift assist spring through left hitch angle mounting plate and eye bolt. Secure eye bolt through bracket with 3/8" lock nut (Fig. 14). Adjust lock nut so there is light spring tension in the fully raised position.



2297

Figure 14

- | | |
|-----------------------|------------------|
| 1. Long link | 5. Eye bolt |
| 2. Notch | 6. Bracket |
| 3. Trunnion | 7. Lock nut 3/8" |
| 4. Lift assist spring | |

8. Open mid-mount hitch and insert rod of idler bracket(Fig. 15).
9. Slide spring onto 3/8 x 1-3/4" bolt and thread on first 3/8" lock nut (Fig.). Place bolt through hole in frame, just in front of mid-mount hitch, and secure with a second 3/8" lock nut (Fig. 15).
10. Hook spring into hole in idler arm assembly.

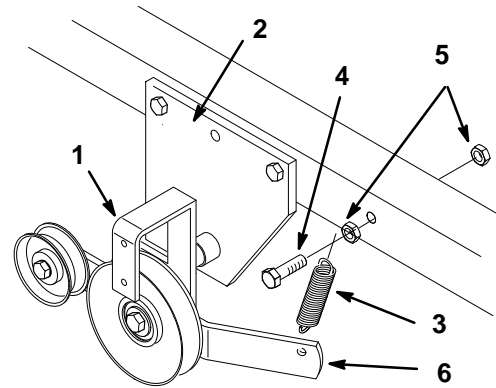

2311

Figure 15

- | | |
|--------------------|-----------------------|
| 1. Mid-mount hitch | 4. Bolt 3/8 x 1-3/4" |
| 2. idler bracket | 5. Lock nut 3/8" |
| 3. Spring | 6. Idler arm assembly |

11. Remove hairpin cotter and trunnion from PTO engagement plate (Fig. 16).
12. Unlatch and remove clevis pin that secures yoke assembly to clutch shaft and pivot forward to remove from engagement plate (Fig. 16).

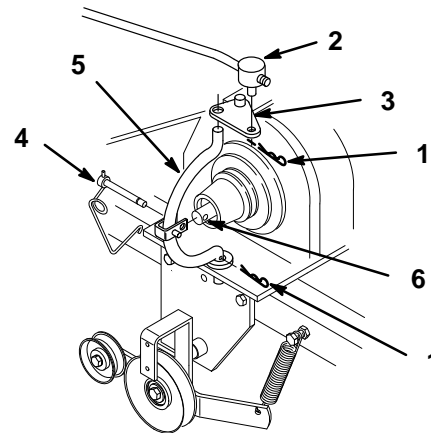

2300

Figure 16

- | | |
|---------------------|-----------------|
| 1. Hairpin cotter | 4. Clevis pin |
| 2. Trunnion | 5. Yoke |
| 3. Engagement plate | 6. Clutch shaft |

13. Loop belt between clutch yoke and engagement plate and place on inner groove of PTO, power take off clutch (Fig. 16).
14. Assemble yoke and engagement plate and attach clevis pin, trunnion and hairpin cotter to secure (Fig. 16).
15. Route belt around and mid-mount idler pulleys, below frame and behind right rear tire (Fig. 17).
16. Pull on idler arm spring to relieve tension and route belt around tiller drive pulley, under tiller idler and inside belt guide (Fig. 17).
17. Check that belt is properly routed around all pulleys and belt guide (Fig. 17).

IMPORTANT: Belt must be properly routed behind belt guide to prevent jumping off and premature failure.

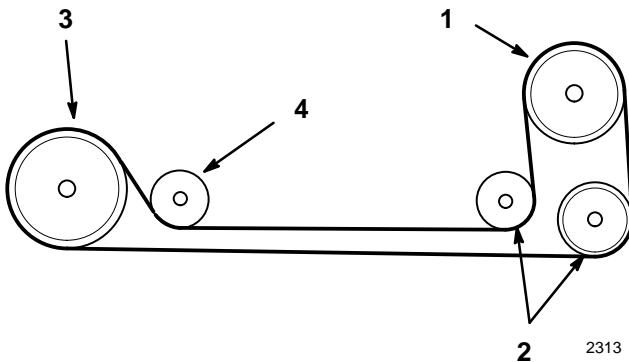
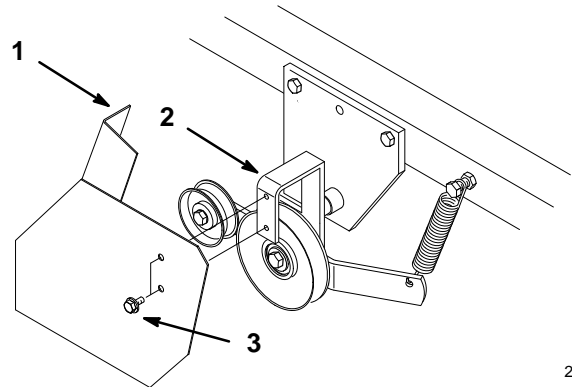

Figure 17

- | | |
|---|------------------|
| 1. Inner groove of (PTO) power take off, clutch | 3. Tiller pulley |
| 2. Mid-mount idler pulleys | 4. Tiller idler |

18. Install belt guard to mid-mount bracket with (2) 1/4 x 1/2" self tapping bolts (Fig. 18).



2312

Figure 18

- | | |
|----------------------|--------------------|
| 1. Belt guard | 3. Bolt 1/4 x 1/2" |
| 2. Mid-mount bracket | |

Removing the Tiller

Note: Save all hardware, washers and hairpin cotters for re-use when installing tiller.

1. Park the machine on a level surface, disengage the power take off (PTO), set the parking brake, and turn the ignition key to "OFF" to stop the engine. Remove the key.
2. Turn the Dial-a-Height knob counterclockwise, all the way and lower the attachment lift lever to the mounting position; refer to Lowering Attachment.
3. Remove the belt guard (Fig. 18).
4. Pull on idler arm spring to relieve belt tension and remove tiller drive belt from tiller pulley and slide belt out of groove (Fig. 19).
5. Remove hairpin cotter and trunnion from power take off PTO engagement plate (Fig. 19).
6. Unlatch and remove clevis pin that secures yoke assembly to clutch shaft and pivot forward to remove from engagement plate (Fig. 19).
7. Remove belt from between clutch yoke and engagement plate (Fig. 19).
8. Assemble yoke and engagement plate and attach clevis pin, trunnion and hairpin cotter to secure (Fig. 19).

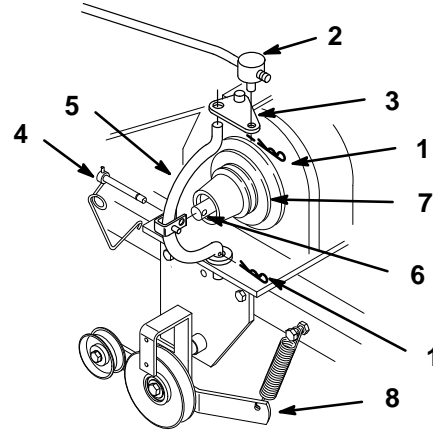

2300

Figure 19

- | | |
|---------------------|-----------------|
| 1. Hairpin cotter | 5. Yoke |
| 2. Trunnion | 6. Clutch shaft |
| 3. Engagement plate | 7. Belt groove |
| 4. Clevis pin | 8. Idler arm |

9. Open mid-mount hitch and remove idler bracket assembly (Fig. 20). Unhook spring from idler arm (Fig. 20).
10. Remove second lock nut from spring mounting bolt and remove (Fig. 20).

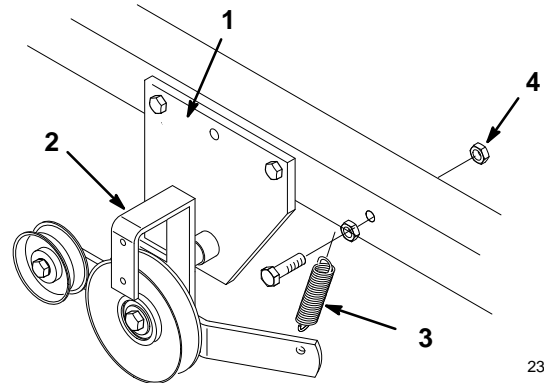

2311

Figure 20

- | | |
|---------------------------|-------------|
| 1. Mid-mount hitch | 3. Spring |
| 2. Idler bracket assembly | 4. Lock nut |

11. Raise attachment lift to the transport position and place a block under tiller gear case.
12. Loosen lock nut on eye bolt and unhook lift assist spring from tractor (Fig. 21).
13. Turn the Dial-a-Height knob counterclockwise, all the way, remove block and lower the attachment lift lever to the mounting position; refer to Lowering Attachment.
14. Remove hairpin cotter and trunnion from lift arm and unhook long link of lift chain from lift arm (Fig. 21). Install trunnion and hairpin cotter (Fig. 21).

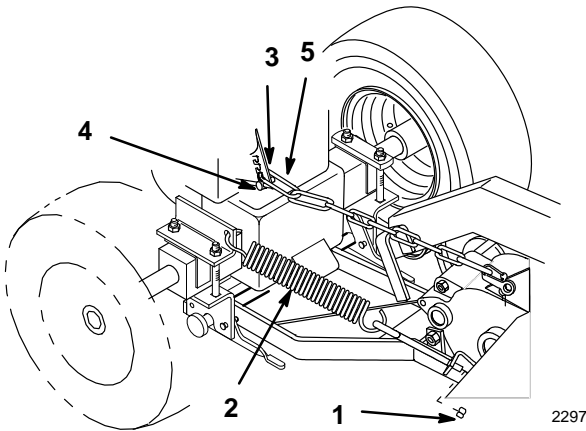

Figure 21

- | | |
|-----------------------|--------------|
| 1. Lock nut | 4. Trunnion |
| 2. Lift assist spring | 5. Long link |
| 3. Hairpin cotter | |

15. Remove hairpin cotters and clevis pins from latch levers (Fig. 22). Open latch levers and remove mounting rod.

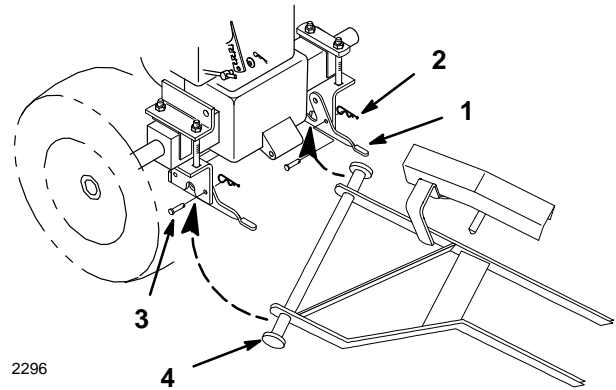

Figure 22

- | | |
|-------------------|-----------------|
| 1. Hairpin cotter | 3. Latch lever |
| 2. Clevis pin | 4. Mounting rod |

Note: Save all hardware, washers and hairpin cotters for reuse when installing tiller.

Operation

DANGER

POTENTIAL HAZARD

- Rotating tines can cut hands, feet or other body parts.

WHAT CAN HAPPEN

- Contact with rotating tines may cause injury.

HOW TO AVOID THE HAZARD

- Keep away from the rotating tines while operating the tiller.
- Keep your hands, feet, and any other part of your body or clothing away from rotating parts.
- Before adjusting, cleaning, repairing and inspecting the tiller, shut off the engine and wait for all moving parts to stop. Move the power take off (PTO) to “OFF” and rotate the ignition key to “OFF.” Remove the key.

Operating the Power Take Off (PTO)

The power take off (PTO) engages and disengages power to the clutch.

Engaging the Power Take Off (PTO)

1. Depress the brake and/or clutch pedal(s) to stop the machine.
2. Move the power take off (PTO) to “ON” (Fig. 23).

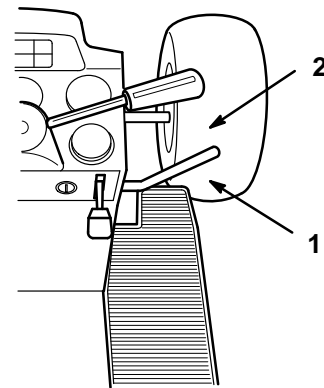

2318

Figure 23

1. Off-Disengaged

2. On-Engaged

Disengaging the Power Take Off (PTO)

1. Depress the brake and/or clutch pedal(s) to stop the machine.
2. Move the power take off (PTO) to “OFF” (Fig.23).

Attachment Lift Lever

The attachment lift lever (Fig. 24) is used to raise and lower various attachments.

Raising Attachments

1. Depress the clutch and/or brake pedal(s) to stop the machine.
2. Pull attachment lift lever rearward until latch locks. In this position the lift will hold the attachment in the up, or raised position.

Lowering Attachments

1. Depress the clutch and/or brake pedal(s) to stop the machine.
2. Pull attachment lift lever rearward, to release lift pressure, and push the button on top to release the latch. Move lift lever forward to lower attachment.

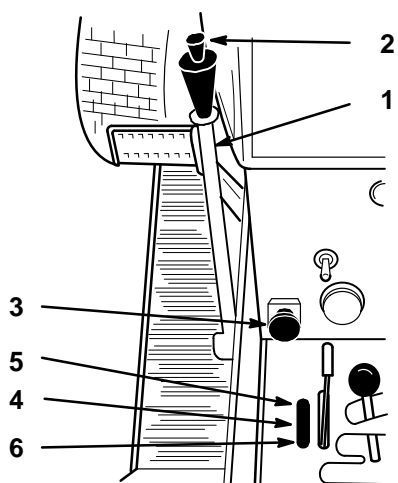

Figure 24

- | | |
|------------------|----------------------|
| 1. Lift lever | 4. Indicator |
| 2. Button | 5. High |
| 3. Dial-A-Height | 6. Mounting position |

2321

Attachment Power Lift

The attachment power lift (optional on some models) (Fig. 25) is used to raise and lower attachments.

Raising Attachments

1. Start the engine.
2. Move the lift lever in the “UP” direction to raise the attachment lift (Fig. 25). This will lift and hold the attachment in the up, or raised position.

Lowering Attachments

1. Start the engine.
2. Move the lift lever in the “DOWN” direction to lower the attachment lift (Fig. 25). This will lower the attachment lift.

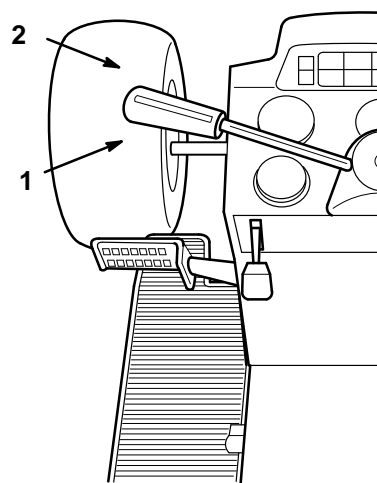

Figure 25

1. Lift lever UP
2. Lift lever DOWN

2317

Adjusting Dial-A-Height

The Dial-A-Height control (Figs. 24) is used to limit the downward travel of the attachment, on gear drive tractors only. The Dial-A-Height knob is rotated to change the location of this stop, up or down.

1. Raise the attachment lift lever: Refer to Raising Attachments. In the raised position the Dial-A-Height knob (Fig. 24) can be rotated to change the stop location. Turn clockwise to raise and counterclockwise to lower the height of the attachment.
2. The Dial-A-Height indicator (Fig. 24) will show the change, high to low, in attachment lift height as adjustment is made.

Adjusting Lift Chain

DANGER

POTENTIAL HAZARD

- Rotating tines can cut hands, feet or other body parts.

WHAT CAN HAPPEN

- Contact with rotating tines may cause injury.

HOW TO AVOID THE HAZARD

- Keep away from the rotating tines while operating the tiller.
- Keep your hands, feet, and any other part of your body or clothing away from rotating parts.
- Before adjusting, cleaning, repairing and inspecting the tiller, shut off the engine and wait for all moving parts to stop. Move the power take off (PTO) to "OFF" and rotate the ignition key to "OFF." Remove the key.

Changing the lift chain link location at the lift arm notch, affects maximum tilling depth, transport lift height and lift effort. The location can be changed at the lever (Fig. 26).

1. For maximum tilling depth and transport lift height locate link of lift chain in the lowest notch of lift lever (Fig. 26). This position will have the greatest lift effort.
2. For minimum tilling depth and reduced lift height, locate the link of lift chain in the upper clevis notch of lift lever (Fig. 26). This position will have lowest lift effort.
3. For variations of less than the three notches in the lift lever, disconnect the lift cable from the lift arm and rotate the trunnion (Fig. 26) Turning clockwise increases lift height and reduces tilling depth and counter clockwise reduces lift height and increases tilling depth.

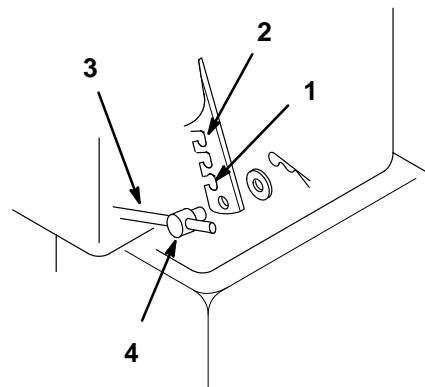

2309

Figure 26

- | | |
|------------------|---------------|
| 1. Lowest notch | 3. Lift cable |
| 2. Highest notch | 4. Trunnion |

Tips for Tilling

Clean area of trash, branches and rocks before tilling to prevent equipment damage.

Always begin tilling with the slowest ground speed possible. Increase speed if conditions permit.

Always use full throttle (maximum engine speed) when tilling.

Always engage the power take off (PTO) with tiller in the raised position.

Till in long straight passes. Do not make turns while tiller is in the ground, as equipment damage may result.

A small center area will not be tilled due to the gear case. Overlapping with a second pass will eliminate this condition.

Avoid excessive tilling of the soil, as finely tilled soil will not absorb moisture easily and puddles of water or run-off may occur.

When tilling hard packed, very dry or virgin soil, raise tiller so only the very top of the soil is penetrated. On succeeding passes the depth may be lowered. This reduces the tendency of the tiller to push the tractor. If this happens, disengage power take off (PTO) and reduce forward speed.

Maintenance

Service Interval Chart

Service Operation	Each Use	5 Hours	25 Hours	Storage Service	Fall Service	Notes
Oil—check level			X	X	X	
Belt—check for wear/cracks				X	X	
Chipped Surfaces—paint				X		

CAUTION

POTENTIAL HAZARD

- If you leave the key in the ignition switch, someone could start the engine.

WHAT CAN HAPPEN

- Accidental starting of the engine could seriously injure you or other bystanders.

HOW TO AVOID THE HAZARD

- Remove the key from the ignition switch and pull the wire off the spark plug before you do any maintenance. Also push the wire aside so it does not accidentally contact the spark plug.

Greasing and Lubrication

Service Interval/Specification

Check the gear lube level in the gear case after every 25 operating hours or once a year, whichever occurs first. Gear lube changes are not required.

Gear lube type: SAE 90-140 API service GL-4 or GL-5.

Refill capacity: 1 qt.

Checking Gear Lube

1. Position the tractor and tiller on a level surface and lower the attachment lift so that the tiller tines are on the ground. Set the parking brake and turn the ignition key to "STOP" to stop the engine. Remove the key.
2. Clean the area around the lower pipe plug (Fig. 27).
3. Remove the pipe plug carefully because the oil level may be above the level of the pipe plug.
4. If gear lube runs from the case when the plug is removed, the lube in the case is sufficient. Oil may be added as necessary.

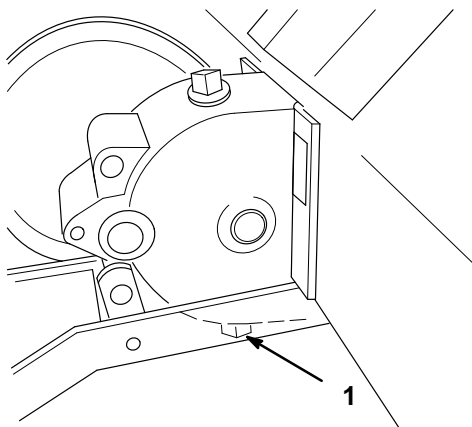

Figure 27

Left side of tiller shown in operating position

1. Pipe plug (hidden)

Adjusting Drive Belt Tension

The drive belt is spring loaded and needs only periodic adjustment, to maintain proper spring tension.

Checking Drive Belt Tension

1. Disengage the power take off (PTO), set the parking brake, and turn the ignition key to "OFF" to stop the engine. Remove the key.
2. As the drive belt wears, and the tiller is raised and lowered, the spring loaded idler arm moves (Fig. 28).
3. Lower the tiller and observe the spring loaded idler arm movement as you push on the belt. The idler arm spring must be under tension. If it is not under tension, replace the drive belt.

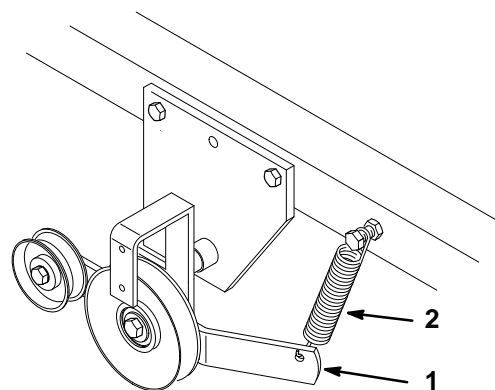

Figure 28

1. Spring loaded idler arm
2. Spring

2319

m-3497

Storage

1. Before long term storage wash the machine with mild detergent and water to remove dirt and grime from the entire machine.
2. Check the condition of the drive belt.
3. Check gearcase lubrication level; refer to Greasing and Lubrication, page 19.
4. Check and tighten all bolts, nuts, and screws. Repair or replace any part that is damaged or defective.
5. Paint all scratched or bare metal surfaces. Paint is available from your Authorized Service Dealer.
6. Store the machine in a clean, dry garage or storage area. Cover the machine to protect it and keep it clean.

