



ProLine Mid-Size

14 HP

Traction Unit

Model No. 30176 – 691913 & UP

Operator's Manual

IMPORTANT: Read this manual carefully. It contains information about your safety and the safety of others. Also become familiar with the controls and their proper use before you operate the product.

Introduction

Thank you for purchasing a Toro product.

All of us at Toro want you to be completely satisfied with your new product, so feel free to contact your local Authorized Service Dealer for help with service, genuine replacement parts, or other information you may require.

Whenever you contact your Authorized Service Dealer or the factory, always know the model and serial numbers of your product. These numbers will help the Service Dealer or Service Representative provide exact information about your specific product. You will find the model and serial number plate located in a unique place on the product as shown below.

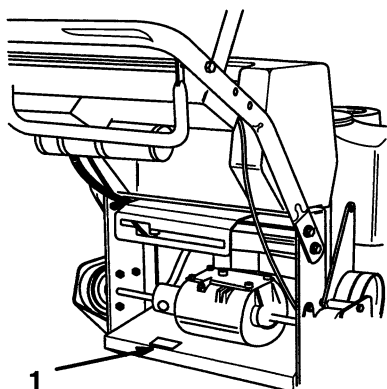

m-2149

1. Model and Serial Number Plate

For your convenience, write the product model and serial numbers in the space below.

Model No: _____
Serial No. _____

Read this manual carefully to learn how to operate and maintain your product correctly. Reading this manual will help you and others avoid personal injury and damage to the product. Although we design, produce and market safe, state-of-the-art products, you are responsible for using the product properly and safely. You are also responsible for training persons, who you allow to use the product, about safe operation.

The warning system in this manual identifies potential hazards and has special safety messages that help you and others avoid personal injury, even death. DANGER, WARNING and CAUTION are signal words used to identify the level of hazard. However, regardless of the hazard, be extremely careful.



DANGER signals an extreme hazard that will cause serious injury or death if the recommended precautions are not followed.

WARNING signals a hazard that may cause serious injury or death if the recommended precautions are not followed.

CAUTION signals a hazard that may cause minor or moderate injury if the recommended precautions are not followed.

Two other words are also used to highlight information. "Important" calls attention to special mechanical information and "Note" emphasizes general information worthy of special attention.

The left and right side of the machine is determined by sitting on the seat in the normal operator's position.

	WARNING:	
<p>The engine exhaust from this product contains chemicals known to the State of California to cause cancer, birth defects, or other reproductive harm.</p>		

Contents

	Page		Page
Safety	2	Operating Mower Blade Control (PTO) ..	17
Safe Operating Practices	2	The Safety Interlock System	17
Slope Chart	5	Driving Forward or Backward	18
Safety and Instruction Decals	7	Stopping the Machine	18
Gasoline and Oil	8	Maintenance	19
Recommended Gasoline	8	Service Interval Chart	19
Stabilizer/Conditioner	8	Air Cleaner	20
Filling the Fuel Tank	8	Engine Oil	21
Check Engine Oil Level	8	Spark Plug	23
Set-Up	9	Greasing and Lubrication	24
Loose Parts	9	Cleaning the Cooling System	25
Install Shift Lever	10	Tire Pressure	25
Mount Control Panel and Fuel Tank	10	Brake	26
Install Upper Handle	11	Fuel Tank	27
Connect Throttle Cable	11	Fuel Filter	28
Connect Wire Harness	12	Replacing the Drive Belt	28
Install Control Rods	12	Replacing the Traction Belt	29
Operation	14	Adjusting the Electric Clutch	29
Think Safety First	14	Wiring Diagram	30
Controls	14	Cleaning and Storage	31
Parking Brake	15	Troubleshooting	32
Starting and Stopping the Engine	16	Warranty	Back Cover

THE ENCLOSED ENGINE OWNER'S MANUAL IS SUPPLIED FOR CALIFORNIA EMISSION CONTROL REGULATION INFORMATION ON EMISSION SYSTEMS, MAINTENANCE AND WARRANTY.

KEEP THIS ENGINE OWNER'S MANUAL WITH YOUR UNIT. SHOULD THIS ENGINE OWNER'S MANUAL BECOME DAMAGED OR ILLEGIBLE, REPLACE IMMEDIATELY. REPLACEMENTS MAY BE ORDERED THROUGH THE ENGINE MANUFACTURER.

Safety

This machine meets or exceeds safety requirements B71.4–1990 of the American National Standards Institute for commercial mowers, in effect at time of production. However, improper use or maintenance by the operator or owner can result in injury. To reduce the potential for injury, comply with these safety instructions and always pay attention to the safety alert  symbol which means CAUTION, WARNING or DANGER—“personal safety instruction.” Failure to comply with the instruction may result in personal injury.

Safe Operating Practices

This product is capable of amputating hands and feet and throwing objects. Always follow all safety instructions to avoid serious injury or death.

WARNING

POTENTIAL HAZARD

- Engine exhaust contains carbon monoxide, which is an odorless, deadly poison.

WHAT CAN HAPPEN

- Carbon monoxide can kill you and is also known to the State of California to cause birth defects.

HOW TO AVOID THE HAZARD

- Do not run engine indoors or in an enclosed area.

This mower is designed for cutting and recycling grass or, when equipped with a grass bag, for catching cut grass. Any use for purposes other than these could prove dangerous to user or bystanders.

Note: This engine is NOT equipped with a spark arrester muffler. Use or operation of this mower in the State of California on any forest-covered, brush-covered or unimproved grass-covered land, without an approved spark arrester muffler, is a violation of the law. Other states may have similar laws.

General Operation

1. Read this manual carefully before operating the mower. Become familiar with the controls and proper use of the mower. Never allow children under 16 years of age to operate the mower. Never allow adults to operate mower without proper instructions.
2. The operator of the mower is responsible for keeping everyone, especially children and pets, away from area of operation. The operator is responsible for accidents or hazards occurring to other people or their property.
3. Thoroughly inspect area where mower will be used and remove sticks, stones, wire, and debris that could be picked up and thrown by mower. Watch for foreign objects while mowing.
4. Wear long pants and substantial shoes. Do not operate mower while wearing open-toed shoes, jewelry, loose clothing or when barefoot.
5. Check fuel level before starting engine. Because fuel is highly flammable, handle it carefully.
 - A. Use an approved fuel container.
 - B. Fill fuel tank outdoors, not indoors.
NEVER ADD FUEL TO AN ENGINE THAT IS RUNNING OR HOT.
 - C. Install gas cap on fuel container and gas tank, and wipe up any spilled gasoline before starting engine.

- D. Do not smoke while refueling.
6. Keep all guards, shields, safety devices, cover-deflector assembly, optional grass catcher, optional side discharge chute or optional discharge tunnel plug in place. Repair or replace damaged parts, including decals. Check all safety devices before each use.
 7. Engine, blade and self-propelled drive (self-propelled model) are designed to stop when control bails are released. Ensure control and brake function properly before each use of mower.
 8. Disengage the self-propelled mechanism or drive clutch (self-propelled model) before starting the engine.
 9. Before using, always visually inspect to see that the blades, blade fasteners and cutter assembly are not worn or damaged. Replace worn or damaged blades and fasteners in sets to preserve balance.

While Operating

1. Do not run engine indoors.
2. Start the engine carefully according to instructions and with feet well away from the blade.
3. Always maintain secure footing. Keep a firm grip on the handle and walk; never run. Never operate mower in wet grass. Mow only in daylight or in good artificial light.
4. Mow across the face of slopes; never up and down. Use extreme caution when changing direction on slopes. Do not mow excessively steep slopes. Wear skid resistant shoes on slopes.
5. Always wear safety glasses or eye shields during operation to protect eyes from foreign objects that may be thrown from the machine.
6. Keep face, hands, and feet away from the mower housing and cutter blade when the engine is running. Blade can cause injury to hands and feet. Stay behind the handle until the engine stops.
7. Use extreme caution when reversing or pulling the mower towards you.
8. Since the blade rotates for a few seconds after the control bar is released, stay behind the handle until all moving parts stop.
9. After striking a foreign object or if mower vibrates abnormally, stop engine and remove wire from spark plug. Check mower for damage and make all repairs before using mower again. If major repairs are ever needed or if assistance is desired, contact your local Authorized TORO Service Dealer.
10. Stop the engine and wait for all moving parts to stop before adjusting the height-of-cut.
11. Stop the blade when pushing the mower outside the lawn area.
12. Stop engine before leaving the operator's position—behind the handle. Disconnect wire from spark plug if mower will be unattended.
13. Do not touch engine while it is running or shortly after it is stopped because engine will be hot enough to cause a burn.
14. Refuel only when engine is cool.
15. If mower must be lifted to be transported, turn off engine and stay behind the handle until all moving parts stop. Disconnect spark plug wire.

Maintenance And Storage

1. Perform only those maintenance instructions described in this manual. If major repairs are ever needed or if assistance is desired, contact your local Authorized TORO Service Dealer.
2. Before mower is cleaned, inspected, serviced, or adjusted, stop engine and disconnect wire from spark plug. Keep wire away from plug to prevent accidental starting.
3. To ensure the mower is in safe operating condition, frequently check and keep all nuts, bolts, and screws tight. Ensure blade bolt is tightened to 85–110 ft-lb (115–149 N·m).
4. When servicing blade, refer to blade maintenance section for correct installation and servicing procedures.
5. To reduce fire hazard, keep engine free of excessive grease, grass, leaves, and accumulations of dirt.
6. Allow engine to cool before storing mower in any enclosure. Do not store mower with gasoline in fuel tank near any open flame or where gasoline fumes may be ignited by a spark.
7. Do not overspeed the engine by changing governor settings.
8. At the time of manufacture, the mower conformed to the safety standards in effect for rotary mowers. To assure best performance and continued safety certification of the mower, use genuine TORO replacement parts and accessories. Replacement parts and accessories made by other manufacturers may result in non-conformance with the safety standards, and that could be dangerous.

Slope Chart

Read all safety instructions on pages 2-7.

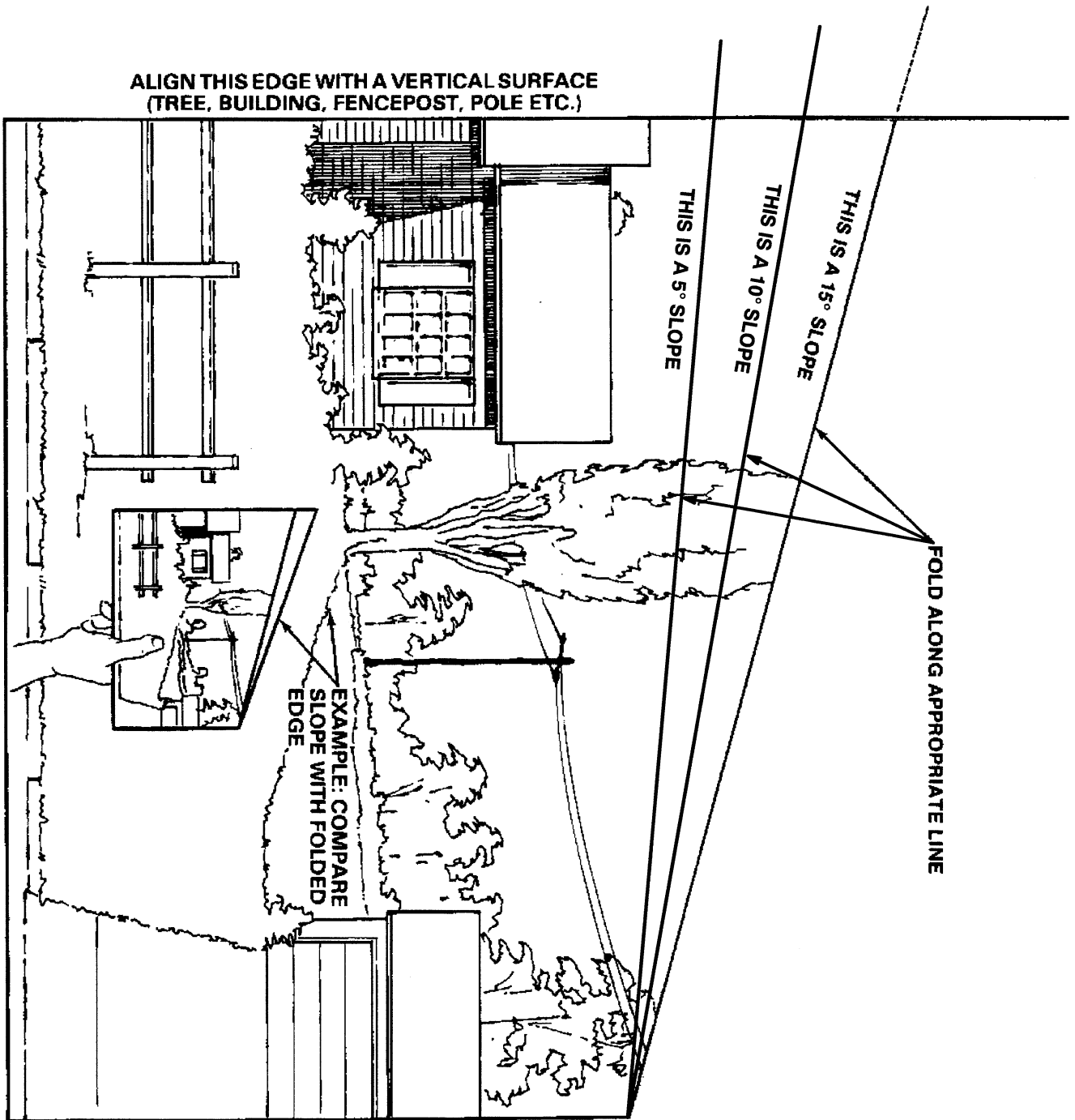

Safety and Instruction Decals



Safety decals and instructions are easily visible to the operator and are located near any area of potential danger. Replace any decal that is damaged or lost.

FORWARD - TRACTION DRIVE

PULL TO BRAKE
ON UPPER CONTROL BAR
 (Part No. 82-2290)

REVERSE - TRACTION DRIVE
ON LOWER CONTROL BAR
 (Part No. 82-2280)

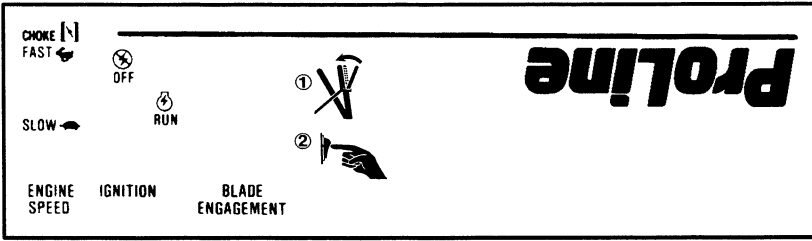
ON CONTROL PANEL
 (Part No. 82-7730)

⚠ DANGER

ROTATING BLADES CAN CUT HANDS/FEET AND THROW OBJECTS.
 • Stop engine before leaving operator position. • Keep bystanders from mowing area. • Keep hands/feet away from blade. • Keep guards in place. • Remove debris from area.

ON CONTROL PANEL
(Part No. 71-1280)

**P
A
R
K
I
N
G
B
R
A
K
E**

IMPORTANT
SHUT OFF FUEL BEFORE TRANSPORTING
ON REAR FRAME
 (Part No. 74-0490)

READ OPERATORS MANUAL BEFORE OPERATING THIS MACHINE. REPLACEMENT MANUAL AVAILABLE BY SENDING MODEL AND SERIAL NUMBER TO THE TOMO CO. 8111 LYNDALE AVE. MINNEAPOLIS, MN 55428
ON CONTROL PANEL
 (Part No. 65-3090)

ON PARKING BRAKE LEVER
(Part No. 52-2010)

USE REVERSE - TRACTION DRIVE BAR ONLY. **DO NOT SHIFT UNDER LOAD. USE FORWARD - TRACTION DRIVE BAR ONLY**
R  **1** **2** **3** **4**
ON CONTROL PLATE
 (Part No. 82-7750)

Gasoline and Oil

Recommended Gasoline

Use UNLEADED Regular Gasoline suitable for automotive use (85 pump octane minimum). Leaded regular gasoline may be used if unleaded regular is not available.

IMPORTANT: Never use methanol, gasoline containing methanol, or gasohol containing more than 10% ethanol because the fuel system could be damaged. Do not mix oil with gasoline.

DANGER

POTENTIAL HAZARD

- In certain conditions gasoline is extremely flammable and highly explosive.

WHAT CAN HAPPEN

- A fire or explosion from gasoline can burn you, others, and cause property damage.

HOW TO AVOID THE HAZARD

- Use a funnel and fill the fuel tank outdoors, in an open area, when the engine is cold. Wipe up any gasoline that spills.
- Do not fill the fuel tank completely full. Add gasoline to the fuel tank until the level is 1/4" to 1/2" (6 mm to 13 mm) below the bottom of the filler neck. This empty space in the tank allows gasoline to expand.
- Never smoke when handling gasoline, and stay away from an open flame or where gasoline fumes may be ignited by a spark.
- Store gasoline in an approved container and keep it out of the reach of children. Never buy more than a 30-day supply of gasoline.

Stabilizer/Conditioner

Add the correct amount of gas stabilizer/conditioner to the gas.

- Keeps gasoline fresh during storage
- Cleans the engine while it runs
- Eliminates gum-like buildup in the fuel system, which causes hard starting

IMPORTANT: Never use fuel additives containing methanol or ethanol.

Filling the Fuel Tank

1. Shut the engine off.
2. Clean around the fuel tank cap and remove the cap. Use a funnel and add unleaded regular gasoline to the fuel tank, until the level is 1/4 to 1/2 inch (6 mm to 13 mm) below the bottom of the filler neck. This space in the tank allows gasoline to expand. Do not fill the fuel tank completely full.
3. Install the fuel tank cap securely. Wipe up any gasoline that may have spilled.

Check Engine Oil Level

Before you start the engine and use the machine, check the oil level in the engine crankcase; refer to Checking Oil Level, page 22.

Set-Up

Loose Parts

Note: Use the chart below to verify all parts have been shipped.

DESCRIPTION	QTY.	USE
Upper handle	1	Install upper handle to frame
Flanged bolt 3/8–16 x 1" (26 mm)	4	
Flange nut 3/8–16	4	
Shift lever	1	Install shift lever to transmission
Shift lever mounting bracket	1	
Washer 1/4"	1	
Bolt 1/4–28 x 2" (51 mm)	1	
Rod fitting	2	Install control rods
Clevis pin	2	
Washer 1/4"	2	
Hairpin cotter	2	
Fuel tank	1	Install fuel tank and control panel
Control panel	1	
Bolt 5/16–1/ x 7/8" (22.5 mm)	4	
Lock washer 5/16"	4	
Washer 5/16"	4	
Hose clamp	2	
Screw self-tapping	1	Install wire harness to frame
Star washer	1	
Wire tie	1	
Operator's Manual	1	Rear before operating machine
Parts Catalog	1	
Registration card	1	Fill out and return to Toro

Install Shift Lever

1. Align mounting block with flats of shaft on top of transmission and slide onto shaft (Fig. 1).

Note: DO NOT remove rubber washer on transmission shaft.

2. Slide shift lever through control panel and align mounting hole in lever with mounting block on transmission. Secure lever to transmission with 2 in. (51 mm) bolt and washer. Torque bolt to 115 in. lb. (155 N.m).

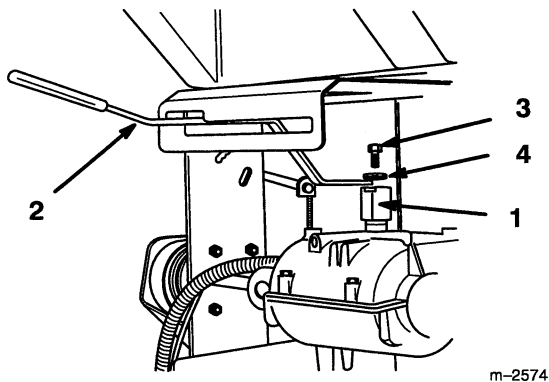

Figure 1

- | | |
|-------------------|-----------------------------|
| 1. Mounting block | 3. Bolt 1/4-28 x 2" (51 mm) |
| 2. Shift lever | 4. Washer |

Mount Control Panel and Fuel Tank

1. Slide control panel over shift lever and under bottom of rear frame (Fig. 2). Align fuel tank to top of rear frame (Fig. 2).

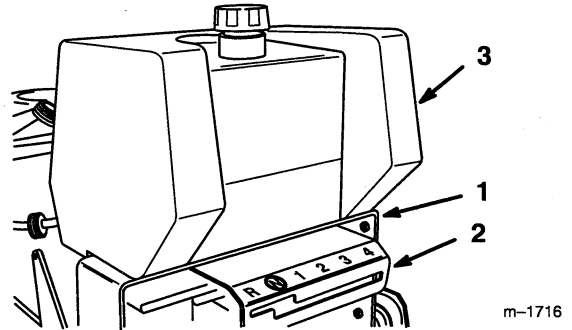

Figure 2

- | | |
|------------------|--------------|
| 1. Rear frame | 3. Fuel tank |
| 2. Control panel | |

2. Secure control panel and fuel tank to rear frame with (4) 7/8 in. (22.5 mm) bolts, lock washers and washers (Fig. 3).

Note: Place transmission in neutral. Align control panel so there is .060 in. (2 mm) space between panel and lever.

3. Slide hose clamp onto fuel line (Fig. 3). Push fuel line onto fuel tank fitting and secure with hose clamp (Fig. 3).

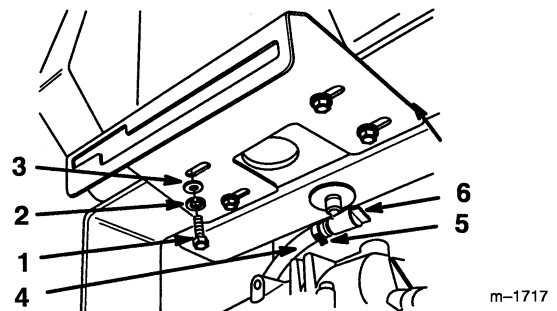

Figure 3

- | | |
|---------------------------------|-----------------|
| 1. Bolt 5/8-18 x 7/8" (22.5 mm) | 4. Fuel line |
| 2. Lock washer | 5. Hose clamp |
| 3. Washer | 6. Fuel fitting |

Install Upper Handle

1. Align upper handle mounting holes with desired mounting holes in rear frame (upper or lower set of holes)
2. Secure each side with (2) 3/8 –16 x 1” (26mm) flange bolts and flange nuts (Fig. 4). Torque bolts to 25 ft. lbs. (34 N.m).
3. Route cables and wire harness inside of frame (Fig. 4). Secure wires and cable to handle with wire tie.

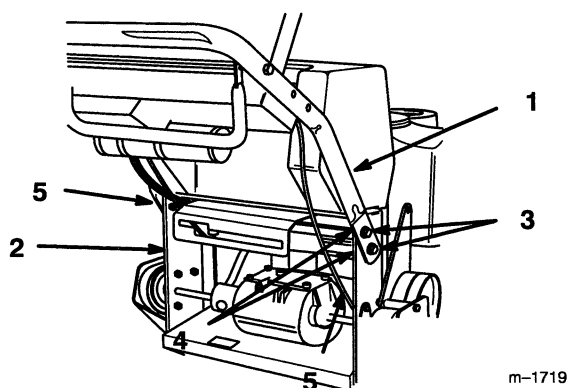

Figure 4

- | | |
|-----------------------------------|---------------------|
| 1. Upper handle | 4. Flange nut 3/8 |
| 2. Rear frame | 5. Wires and cables |
| 3. Flange bolt 3/8 x 16-1” (26mm) | |

Connect Throttle Cable

1. Place throttle control lever in FAST position.(Fig. 5).
2. Hook wire Z-bend into hole of speed control lever (Fig. 5).
3. Loosen cable clamp screw allowing cable installation, but do not tighten (Fig. 5).
4. Move control cable casing and wire until hole in speed control lever is aligned with hole in base plate. Insert a 1/4 in. (6.35 mm) diameter pin or bolt into aligned holes to hold adjustment.
5. Pull throttle cable slightly to remove any slack and tighten cable clamp screw to lock adjustment in place.
6. Remove alignment pin and check control operation.

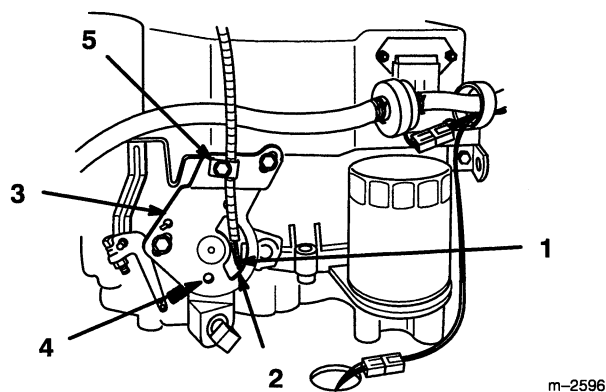

Figure 5

- | | |
|------------------------|-------------------------------------|
| 1. Wire Z-bend | 4. Alignment holes 1/4 in. (6.35mm) |
| 2. Speed control lever | 5. Cable clamp |
| 3. Base plate | |

Connect Wire Harness

1. Route regulator wires through J-clip on engine, and plug in clutch and engine in-line wire connectors (Fig. 6).
2. Secure ground wire to one of three holes in frame, at rear of engine, with self-tapping screw and star washer (Fig. 6).
3. Secure wire harness and throttle to upper handle with cable tie (Fig. 6)

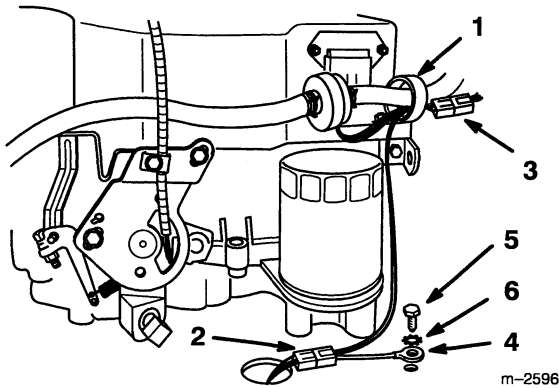
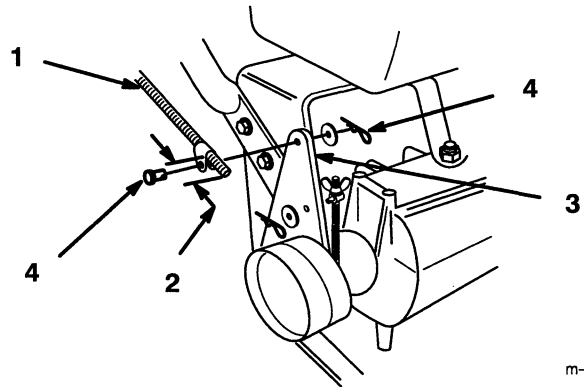

Figure 6

- | | |
|--------------------------|-----------------------|
| 1. J-clip | 4. Ground wire |
| 2. Clutch wire connector | 5. Screw-self tapping |
| 3. Engine wire connector | 6. Star washer |

Install Control Rods

1. Thread rod fittings equal distance onto each control rod. For a starting point thread on approximately 2 in. (51 mm) (Fig. 7).
2. Slide clevis pins through rod fittings and mounting holes in idler brackets (from outside) (Fig. 7). Secure with washers and hairpin cotters (Fig. 7).



m-2073

Figure 7

- | | |
|----------------------------|--|
| 1. Control rod and fitting | 4. Clevis pin, washer and hairpin cotter |
| 2. 2 in. (51 mm) | |
| 3. Idler bracket | |

3. Check the gap between upper control bar and fixed bar with wheel drive fully engaged. Gap should be approximately 1 to 1-1/4 in. (25–32 mm) (Fig. 8).

Note: The upper control bar and fixed bar must be parallel when in engaged, drive, relaxed and brake positions.

4. Check operation. If adjustment is required, remove hairpin cotter securing rod to upper control bar. Thread rod in or out of fitting for proper position and install into upper control bar with hairpin cotter.

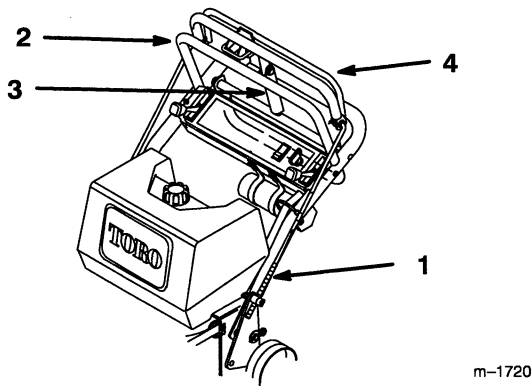

Figure 8

- | | |
|----------------------|------------------------|
| 1. Control rod | 3. Parking brake lever |
| 2. Fixed control bar | 4. Upper control bar |

5. Check parking brake adjustment. Brake rods should be adjusted so parking brake lever is snug when swung into position against the fixed bar while pulling back on upper control bar (Fig. 8).

6. If brake adjustment is required, remove hairpin cotter and washer securing brake rod fitting to idler bracket (Fig. 9).

7. Adjust wing nut up or down on brake rod and secure fitting to idler bracket (Fig. 9). Check adjustment and readjust if necessary.

Note: Make sure brake rod is installed in front (“F”) mounting hole in idler bracket.

8. Repeat procedure on opposite side if adjustment is required to keep control bar and fixed bar.

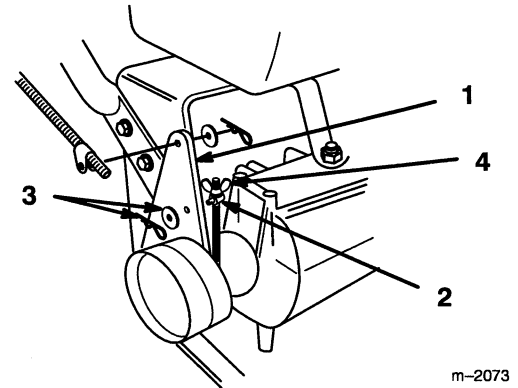

Figure 9

- | | |
|----------------------|------------------------------|
| 1. Idler bracket | 3. Hairpin cotter and washer |
| 2. Brake rod fitting | 4. Wing nut |

Operation

Think Safety First

Please carefully read all the safety instructions and symbols in the safety section. Knowing this information could help you, your family, pets or bystanders avoid injury.

Controls

Become familiar with all the controls (Fig. 10) before you start the engine and operate the machine.

Throttle Control – The throttle control has three positions: CHOKE, FAST and SLOW.

Deck Engagement Control Bail – Control bail used in conjunction with deck engagement switch (PTO) to release blade brake and engage clutch to drive mower blades. Release bail to disengage mower blades.

Blade Control Switch (PTO) – Rocker switch used in conjunction with control bail to release blade brake and engage clutch to drive mower blades.

Gear Shift Lever – Transmission has four forward speeds, neutral and reverse, and has an in-line shift pattern. Do not shift while unit is moving, as transmission damage may occur.

Upper Control Bar – Shift to desired gear and push forward on control bar to engage forward traction operation and pull back to brake. Pull right side of control bar to turn right and left side to turn left.

Lower Control Bar – Shift transmission to reverse and pull rearward on lower control bar to engage rearward traction operation.

Parking Brake Lever – Pull back on upper control bar and swing brake lever up against the upper handle.

Ignition Switch – Key switch is used in conjunction with recoil starter. Switch has two positions: RUN and OFF.

Recoil Starter – Pull recoil Starter handle to start engine.

Fuel Shut-off Valve – (Under fuel tank) Close fuel shut-off valve when transporting or storing mower.

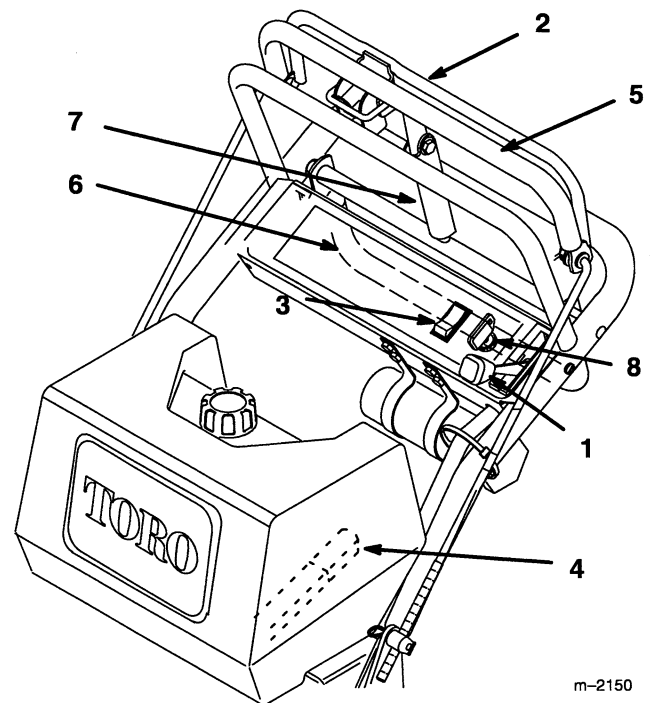

Figure 10

- | | |
|-------------------------------|------------------------|
| 1. Throttle control | 5. Upper control bar |
| 2. Blade control bail | 6. Lower control bar |
| 3. Blade control switch (PTO) | 7. Parking brake lever |
| 4. Gear shift lever | 8. Ignition switch |

Parking Brake

Always set the parking brake when you stop the machine or leave it unattended.

Setting the Parking Brake

1. Pull the upper control bar (Fig. 11) rearward and hold it in this position.
2. Lift the parking brake lock (Fig. 11) up and gradually release the upper control bar. The brake lock should stay in the set (locked) position.

Releasing the Parking Brake

1. Pull rearward on the upper control bar (Fig. 11). Lower the parking brake lock to the released position.
2. Gradually release the upper control bar.

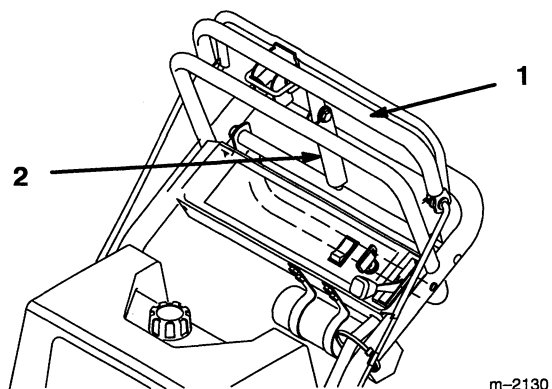

Figure 11

1. Upper control bar

2. Parking brake lock

Starting and Stopping the Engine

Starting

1. Make sure spark plug wire(s) are installed on spark plug(s) and fuel valve is open.
2. Move the shift lever to neutral, set the parking brake and turn ignition key to RUN.
3. Move the throttle control to CHOKE position before starting a cold engine.

Note: A warm or hot engine usually does not require any choking. To start a warm engine, move throttle control to FAST position.

4. Grasp recoil starter handle firmly and pull out until positive engagement results; then pull handle vigorously to start engine and allow rope to recoil slowly.

IMPORTANT: Do not pull recoil rope to its limit or let go of the starter handle when rope is pulled out because rope may break or recoil assembly may be damaged.

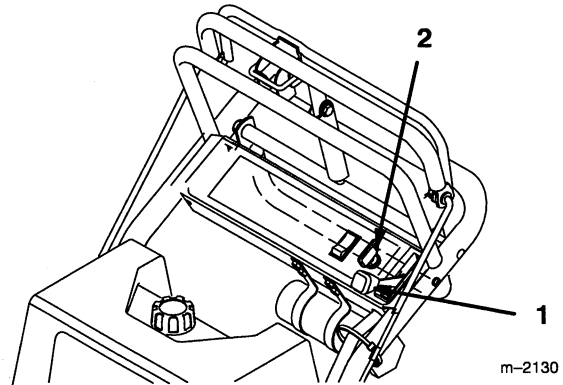

Figure 12

1. Throttle lever 2. Ignition key
-

3. Set the parking brake.
4. Pull wire off spark plug(s) to prevent possibility of accidental starting before storing machine.
5. Close fuel shut off valve before storing machine.

IMPORTANT: Make sure fuel shut off valve is closed before transporting or storing machine, as fuel leakage may occur.

Stopping

1. Move the throttle lever to "SLOW" (Fig. 12).

Note: If the engine has been working hard or is hot, let it idle for a minute before turning the ignition key "OFF." This helps cool the engine before it is stopped. In an emergency, the engine may be stopped by turning the ignition key to "OFF."

2. Turn the ignition key to "OFF" (Fig. 12).

Operating Mower Blade Control (PTO)

The blade control switch (PTO) in conjunction with the blade control bail engages and disengages power to the electric clutch and mower blades.

Engaging the Mower Blades (PTO)

1. Pull on the upper control bar to stop the machine (Fig. 13).
2. To engage blade, squeeze blade control bail against upper control bar
3. Press rocker switch forward "ON" and release. Hold blade control bail against control bar while operating.
4. Repeat procedure to engage mower blades if blade control bail is released.

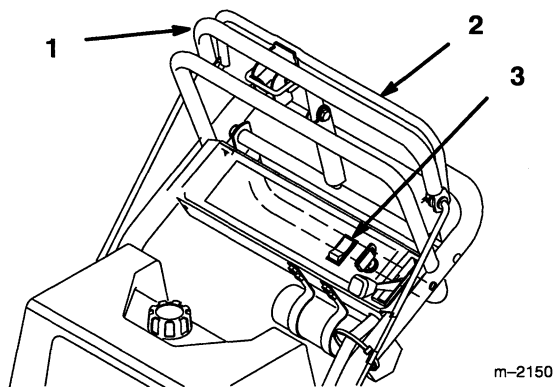

Figure 13

- | | |
|-----------------------|-------------------------------|
| 1. Upper control bar | 3. Blade control switch (PTO) |
| 2. Blade control bail | |

Disengaging the Mower Blades (PTO)

1. Releasing blade control bail to disengage blades (PTO) (Fig. 13).
2. Or push the blade control switch (PTO) to the "OFF" position (Fig. 13).

The Safety Interlock System

Understanding the Safety Interlock System

The safety interlock system is designed to prevent the mower blades from rotating unless:

- The control bail is depressed
- The blade control switch (PTO) is pressed "ON"

The safety interlock system is designed to stop the mower blades if you released the blade control bail.

Testing the Safety Interlock System

Test the safety interlock system before you use the machine each time. If the safety system does not operate as described below, have an Authorized Service Dealer repair the safety system immediately.

1. Set the parking brake and start the engine :refer to Starting and Stopping the Engine, page 16
2. Squeeze the blade control bail against upper control bar. The blades should not rotate.
3. Then continue holding the blade control bail and press the rocker switch forward "ON" and release. The clutch should engage and the mower blades begin rotating.
4. Release the blade control bail. The blades should stop rotating.
5. Then push the blade control switch (PTO) to "ON" without holding the blade control bail. The blades should not rotate.

Driving Forward or Backward

The throttle control regulates the engine speed as measured in rpm (revolutions per minute). Place the throttle control in the “FAST” position for best performance.

Forward

1. To go forward, move the shift lever to a forward gear.
2. Release the parking brake: refer to Releasing the Parking Brake, page 15.
3. Slowly press on the upper control bar to move forward (Fig. 14).

To go straight, apply equal pressure to both ends of the upper control bar (Fig. 14).

To turn, release pressure on the upper control bar side away from the direction you want to turn (Fig. 14).

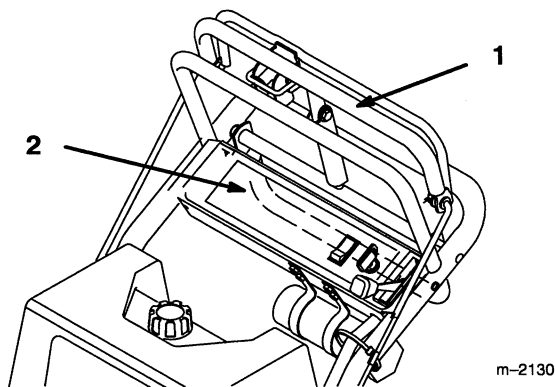

Figure 14

1. Upper control bar 2. Lower control bar

Backward

1. To go backward, move the shift lever to reverse gear.
2. Release the parking brake: refer to Releasing the Parking Brake, page 15.
3. Slowly pull on the lower control bar to move rearward (Fig. 14).

Stopping the Machine

To stop the machine, pull back on the upper control bar, release the blade control bail (PTO), and turn the ignition key to “OFF” to stop the engine. Also set the parking brake if you leave the machine unattended; refer to Setting the Parking Brake, page 15. Remember to remove the key from the ignition switch.

CAUTION

POTENTIAL HAZARD

- Someone could move or attempt to operate the machine while it is unattended.

WHAT CAN HAPPEN

- Children or bystanders may be injured if they use the machine.

HOW TO AVOID THE HAZARD

- Always remove the ignition key and set the parking brake when leaving the machine unattended, even if just for a few minutes.

Maintenance

Service Interval Chart

Service Operation	Each Use	8 Hours	25 Hours	50 Hours	100 Hours	200 Hours	Storage Service
Oil—check level	X						X
Oil—change*		Initial			X		X
Oil Filter—change (200 hours or every other oil change)						X	X
Safety System—check	X						X
Brake—check	X						X
Wheel Bearings—grease*		X					X
Transmission Couplings—grease*						X	X
Foam Air Cleaner—service*			X				X
Paper Air Cleaner—replace*					X		X
Spark Plug(s)—check						X	X
Belts—check for wear/cracks				X			X
Electric Clutch—Adjust					X		X
Gasoline—drain							X
Engine—clean cooling system	X				X		X
Fuel Filter—replace						X	X
Tires—check pressure				X			X
Chipped Surfaces—paint							X
* More often in dusty, dirty conditions							

CAUTION

POTENTIAL HAZARD

- If you leave the key in the ignition switch, someone could start the engine.

WHAT CAN HAPPEN

- Accidental starting of the engine could seriously injure you or other bystanders.

HOW TO AVOID THE HAZARD

- Remove the key from the ignition switch and pull the wire(s) off the spark plug(s) before you do any maintenance. Also push the wire(s) aside so it does not accidentally contact the spark plug(s).

Air Cleaner

Service Interval/Specification

Foam Element: Clean and re-oil after every 25 operating hours.

Paper Element: Replace after every 100 operating hours.

Note: Service the air cleaner more frequently (every few hours) if operating conditions are extremely dusty or sandy.

Removing the Foam and Paper Elements

1. Disengage the power take off (PTO), set the parking brake, and turn the ignition key to "OFF" to stop the engine. Remove the key.
2. Clean around the air cleaner to prevent dirt from getting into the engine and causing damage. Unscrew the cover nut and remove the air cleaner cover (Fig. 15).
3. Remove the air cleaner assembly (Fig. 15).
4. Carefully slide the foam element off the paper element (Fig. 15).

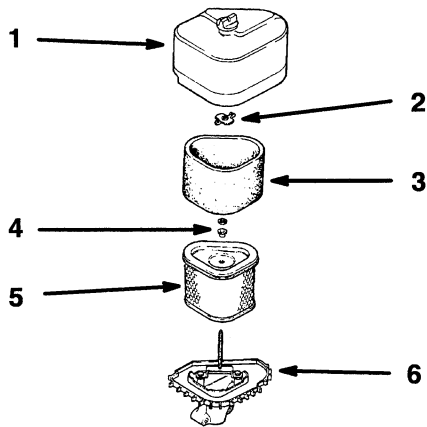

Figure 15

m-2595

- | | |
|------------------|-----------------------|
| 1. Cover and nut | 4. Washer and grommet |
| 2. Wing nut | 5. Paper element |
| 3. Foam element | 6. Air cleaner base |

Cleaning the Foam and Paper Elements

1. Foam Element

- A. Wash the foam element in liquid soap and warm water. When the element is clean, rinse it thoroughly.
- B. Dry the element by squeezing it in a clean cloth.
- C. Put one or two ounces of oil on the element (Fig. 16). Squeeze the element to distribute the oil.

IMPORTANT: Replace the foam element if it is torn or worn.

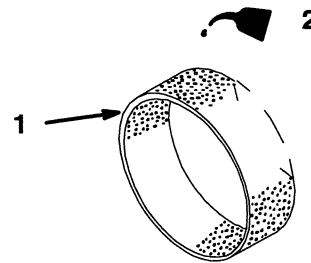

m-1213

Figure 16

- | | |
|-----------------|--------|
| 1. Foam element | 2. Oil |
|-----------------|--------|

2. Paper Element

- A. Lightly tap the element on a flat surface to remove dust and dirt (Fig. 17).
- B. Inspect the element for tears, an oily film, and damage to the rubber seal.

IMPORTANT: Never clean the paper element with pressurized air or liquids, such as solvent, gas, or kerosene. Replace the paper element if it is damaged, defective, or cannot be cleaned thoroughly.

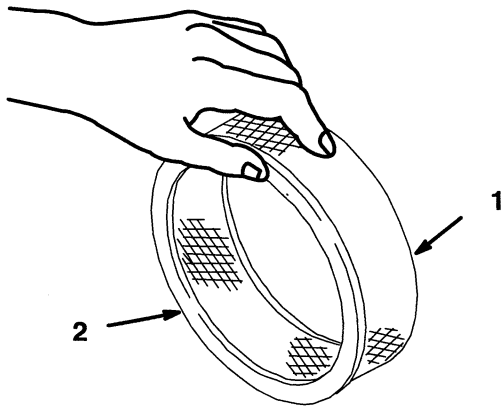

m-1213

Figure 17

- 1. Paper element
- 2. Rubber seal

Installing the Foam and Paper Elements

1. Installing the Foam and Paper Elements

IMPORTANT: To prevent engine damage, always operate the engine with the complete foam and paper air cleaner assembly installed.

- 1. Carefully slide the foam element onto the paper air cleaner element (Fig. 15).
- 2. Place the air cleaner assembly onto the air cleaner base (Fig. 15).
- 3. Install the air cleaner cover and secure with cover nuts (Fig. 15).

Engine Oil

Service Interval/Specification

Change oil:

- After the first 8 operating hours.
- After every 100 operating hours.

Note: Change oil more frequently when operating conditions are extremely dusty or sandy.

Oil Type: Detergent oil (API service SF, SG or SH)

Crankcase Capacity: w/filter, 2 qt. (1.9 l)

Viscosity: See table below

USE THESE SAE VISCOSITY OILS

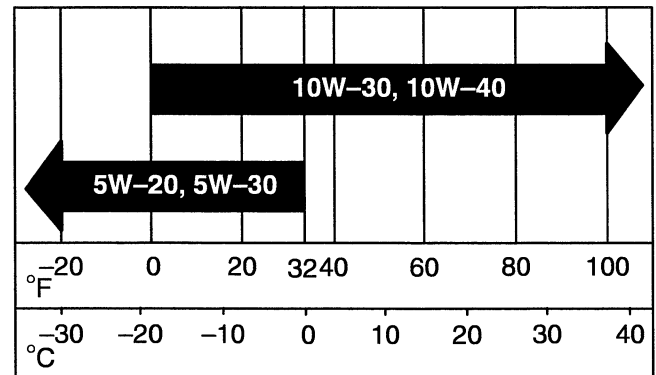

Checking Oil Level

1. Park the machine on a level surface, disengage the power take off (PTO), set the parking brake, and turn the ignition key to "OFF" to stop the engine. Remove the key.
2. Clean around the oil dipstick (Fig. 18) so dirt cannot fall into the filler hole and damage the engine.
3. Unscrew the oil dipstick and wipe the metal end clean (Fig. 18).
4. Slide the oil dipstick fully into the filler tube, do not thread onto tube (Fig. 18). Pull the dipstick out and look at the metal end. If oil level is low, slowly pour only enough oil into the filler tube to raise the level to the "FULL" mark.

IMPORTANT: Do not overfill the crankcase with oil because the engine may be damaged.

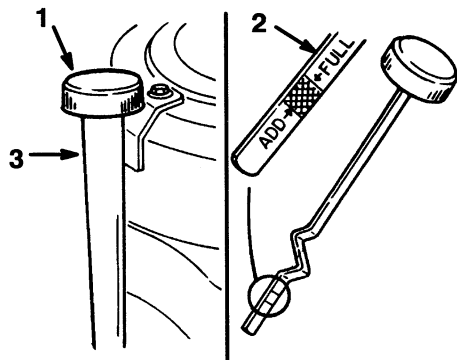

Figure 18

1. Oil dipstick
2. Metal end
3. Filler tube

Changing/Draining Oil

1. Start the engine and let it run five minutes. This warms the oil so it drains better.
2. Park the machine so that the drain side is slightly lower than the opposite side to assure the oil drains completely. Then disengage the power take off (PTO), set the parking brake, and turn the ignition key to "OFF" to stop the engine. Remove the key.
3. Place a pan below the oil drain. Remove the oil drain cap (Fig. 19).
4. When oil has drained completely, install the oil drain cap.

Note: Dispose of the used oil at a certified recycling center.

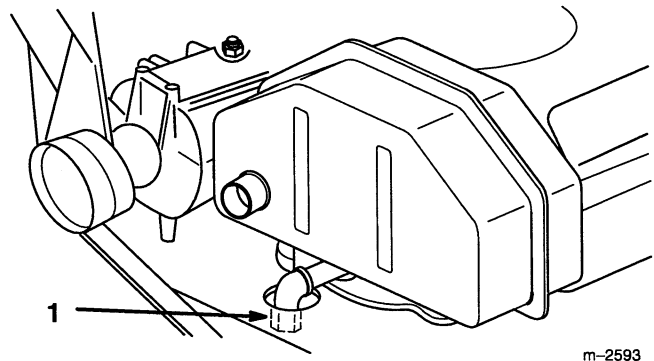

Figure 19

1. Oil drain cap

5. Slowly pour approximately 80% of the specified amount of oil specified, page 21, into the filler tube (Fig. 18). Now check the oil level; refer to Checking Oil Level, page 22. Slowly add additional oil to bring to "FULL" mark on dipstick.

Change Oil Filter

Service Interval/Specification

Replace the oil filter every 200 hours or every other oil change.

Note: Change oil filter more frequently when operating conditions are extremely dusty or sandy.

1. Drain the oil from the engine; refer to Changing/Draining Oil, page 22.
2. Remove the old filter and wipe the filter adapter (Fig. 20) gasket surface.
3. Apply a thin coat of new oil to the rubber gasket on the replacement filter (Fig. 20).

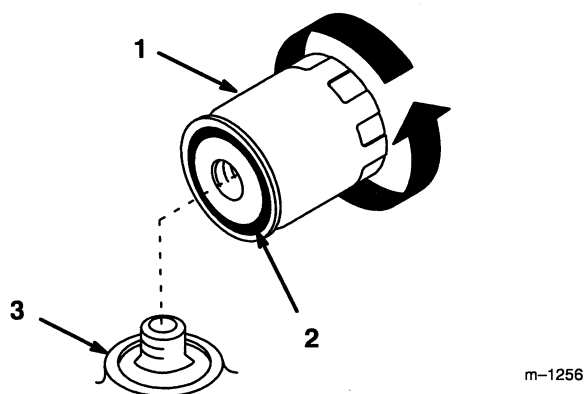

Figure 20

- | | |
|---------------|------------|
| 1. Oil filter | 3. Adapter |
| 2. Gasket | |

4. Install the replacement oil filter to the filter adapter. Turn the oil filter clockwise until the rubber gasket contacts the filter adapter, then tighten the filter an additional 1/2 turn (Fig. 20).
5. Fill the crankcase with the proper type of new oil; refer to Changing/Draining Oil, page 22.

Spark Plug

Service Interval/Specification

Check the spark plug(s) after every 200 operating hours. Make sure the air gap between the center and side electrodes is correct before installing the spark plug. Use a spark plug wrench for removing and installing the spark plug(s) and a gapping tool/feeler gauge to check and adjust the air gap. Install a new spark plug(s) if necessary.

Type: Champion RC12YC (or equivalent) Air Gap: 0.040 in. (1.02 mm)

Removing the Spark Plug(s)

1. Disengage the power take off (PTO), set the parking brake, and turn the ignition key to "OFF" to stop the engine. Remove the key.
2. Pull the wire(s) off the spark plug(s) (Fig. 21). Now clean around the spark plug(s) to prevent dirt from falling into the engine and potentially causing damage.
3. Remove the spark plug(s) and metal washer.

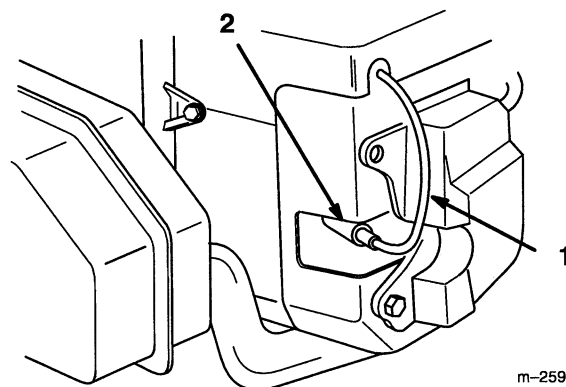

Figure 21

- | | |
|--------------------|---------------|
| 1. Spark plug wire | 2. Spark plug |
|--------------------|---------------|

Checking the Spark Plug

1. Look at the center of the spark plug(s) (Fig. 22). If you see light brown or gray on the insulator, the engine is operating properly. A black coating on the insulator usually means the air cleaner is dirty.

IMPORTANT: Never clean the spark plug(s). Always replace the spark plug(s) when it has: a black coating, worn electrodes, an oily film, or cracks.

2. Check the gap between the center and side electrodes (Fig. 22). Bend the side electrode (Fig. 22) if the gap is not correct.

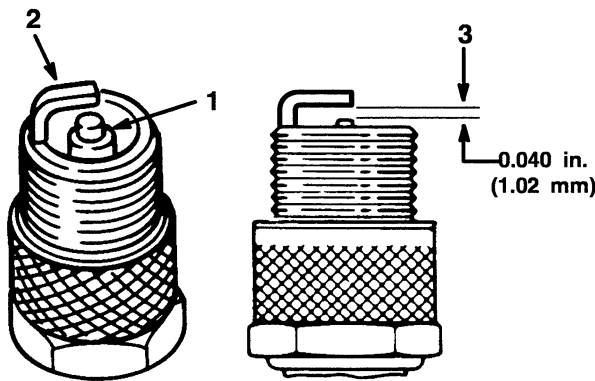

Figure 22

1. Center electrode insulator
2. Side electrode
3. Air gap (not to scale)

Installing the Spark Plug(s)

1. Install the spark plug(s) and metal washer. Make sure the air gap is set correctly.
2. Tighten the spark plug(s) to 20 ft-lb (27 N.m).
3. Push the wire(s) onto the spark plug(s) (Fig. 21).

Greasing and Lubrication

Service Interval/Specification

Grease the wheel bearings every 8 operating hours and the transmission couplers every 200 operating hours. Grease more frequently when operating conditions are extremely dusty or sandy.

Grease Type: General-purpose grease.

How to Grease

1. Disengage the power take off (PTO), set the parking brake, and turn the ignition key to "OFF" to stop the engine. Remove the key.
2. Clean the grease fittings with a rag. Make sure to scrape any paint off the front of the fitting(s).
3. Connect a grease gun to the fitting. Pump grease into the fittings until grease begins to ooze out of the bearings.
4. Wipe up any excess grease.

Where to Add Grease

1. Lubricate the wheel bearings and front spindles until grease begins to ooze out of the bearings (Fig. 23).

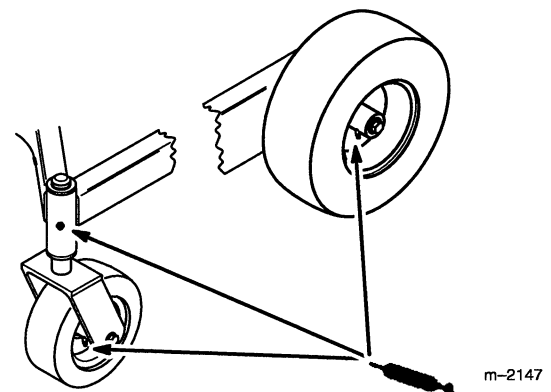
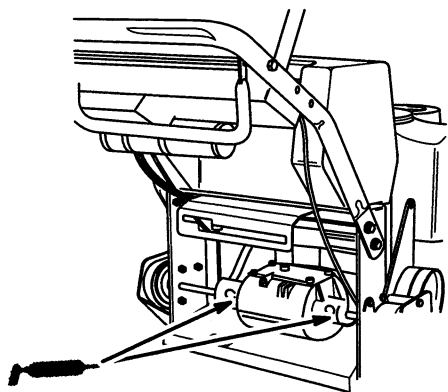

Figure 23

- Lubricate the transmission couplers (Fig. 24).



m-2067

Figure 24

Cleaning the Cooling System

Service Interval/Specification

Before each use, check and clean engine cooling system. Remove any build-up of grass, dirt or other debris from the cylinder and cylinder head cooling fins, air intake screen on flywheel end, and carburetor-governor levers and linkage. This will help insure adequate cooling and correct engine speed and will reduce the possibility of overheating and mechanical damage to the engine.

Tire Pressure

Service Interval/Specification

Maintain the air pressure in the front and rear tires as specified. Check the pressure at the valve stem after every 50 operating hours or monthly, whichever occurs first (Fig. 25). Check the tires when they are cold to get the most accurate pressure reading.

Pressure: 15 psi (.103 kPa) rear and castor tires

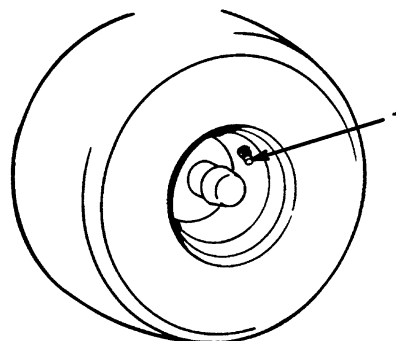

Figure 25

1. Valve stem

Brake

Service Interval/Specification

Before each use, check brakes for proper operation.

Always set the parking brake when you stop the machine or leave it unattended. If the parking brake does not hold securely, an adjustment is required.

Checking the Brake

1. Park the machine on a level surface, disengage the power take off (PTO), set the parking brake, and turn the ignition key to "OFF" to stop the engine. Remove the key.
2. Rear wheels must lock when you try to push the machine forward. Adjustment is required if the wheels turn and do not lock; refer to Adjusting the Brake, page 26.
3. Release the brake and press upper control bar very lightly, approximately 1/2 in. (13 mm), wheels should rotate freely.
4. If both conditions are met no adjustment is required.

Adjusting the Brake

The brake lever is on the upper control bar (Fig. 10). If the parking brake does not hold securely, an adjustment is required.

1. Check the brake before you adjust it; refer to Checking the Brake, page 26.
2. Release the parking brake; refer to Releasing the Parking Brake, page 15.
3. To adjust the brake remove the cotter pin and washer from the brake lever (Fig. 26).
4. Rotate the trunnion so it smoothly slides into brake lever (Fig. 26). Tighten wing nut.
5. Secure trunnion to brake lever with washer and cotter pin (Fig. 26).
6. Check the brake operation again; refer to Checking the Brake, page 26.

IMPORTANT: With the parking brake released, the rear wheels must rotate freely when you push the mower. If brake action and free wheel rotation cannot be achieved contact your service dealer immediately.

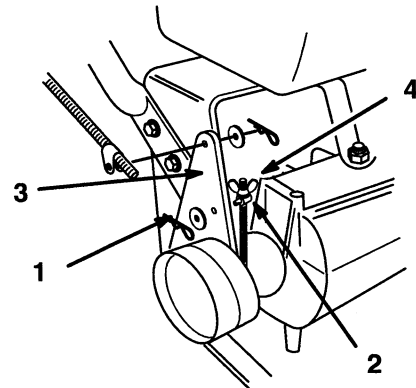

m-2073

Figure 26

- | | |
|------------------------------|----------------|
| 1. Hairpin cotter and washer | 3. Brake lever |
| 2. Trunnion | 4. Wing nut |

Fuel Tank

Draining The Fuel Tank

DANGER

POTENTIAL HAZARD

- In certain conditions gasoline is extremely flammable and highly explosive.

WHAT CAN HAPPEN

- A fire or explosion from gasoline can burn you, others, and cause property damage.

HOW TO AVOID THE HAZARD

- Drain gasoline from the fuel tank when the engine is cold. Do this outdoors in an open area. Wipe up any gasoline that spills.
- Never drain gasoline near an open flame or where gasoline fumes may be ignited by a spark.
- Never smoke a cigarette, cigar or pipe.

1. Park the machine on a level surface, to assure fuel tank drains completely. Then disengage the power take off (PTO), set the parking brake, and turn the ignition key to "OFF" to stop the engine. Remove the key.
2. Close fuel shut-off valve at fuel tank (Fig. 27).
3. Squeeze the ends of the hose clamp together and slide it up the fuel line away from valve (Fig. 27).
4. Pull the fuel line off the valve (Fig. 27). Open fuel shut-off valve and allow gasoline to drain into a gas can or drain pan.

Note: Now is the best time to install a new fuel filter because the fuel tank is empty. Refer to Replacing the Fuel Filter; page 28.

5. Install the fuel line onto the valve. Slide the hose clamp close to the valve to secure the fuel line.

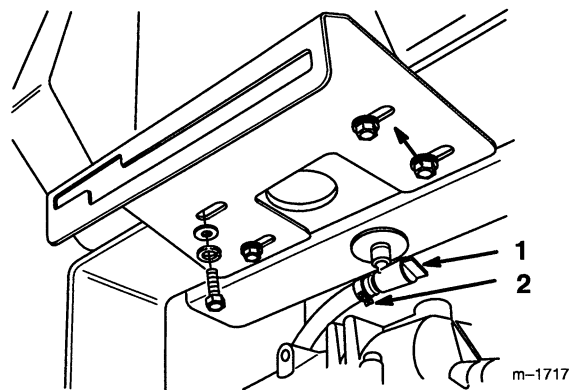

Figure 27

1. Fuel shut-off valve

2. Clamp

Fuel Filter

Service Interval/Specification

Replace the fuel filter after every 200 operating hours or yearly, whichever occurs first.

Replacing the Fuel Filter

Never install a dirty filter if it is removed from the fuel line.

1. Disengage the power take off (PTO), set the parking brake, and turn the ignition key to "OFF" to stop the engine. Remove the key.
2. Close fuel shut-off valve at fuel tank (Fig. 27).
3. Squeeze the ends of the hose clamps together and slide them away from the filter (Fig. 28).
4. Remove the filter from the fuel lines.
5. Install a new filter and move the hose clamps close to the filter.
6. Open fuel shut-off valve at fuel tank (Fig. 27).

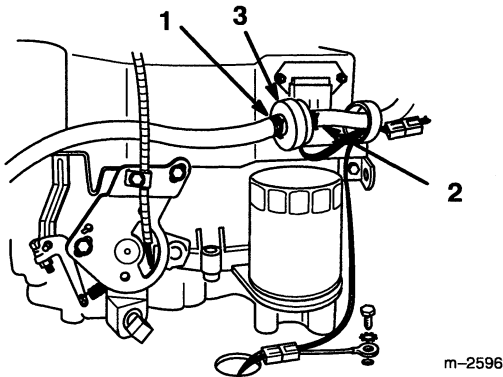

Figure 28

1. Hose clamp
2. Fuel line
3. Filter

Replacing the Drive Belt

Service Interval/Specification

Check all belts after every 50 operating hours or monthly, whichever occurs first. Look for dirt, wear, cracks and signs of overheating.

1. Remove top capscrew securing idler support and idler bracket to rear frame (Fig. 29).
2. Loosen bottom two mounting screws enough to allow belt to pass between drive pulley and idler support (Fig. 29).
3. Raise wheel off ground enough to allow belt removal.

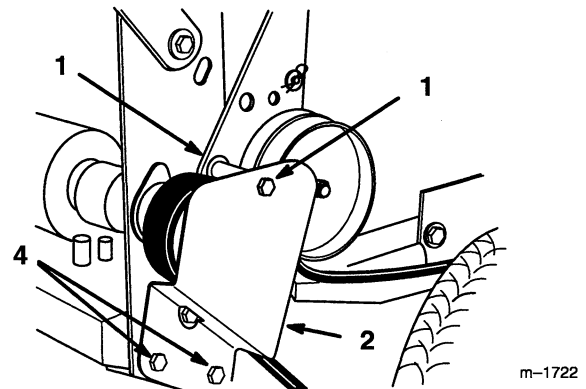

Figure 29

1. Top capscrew
2. Idler bracket
3. Idler support
4. Bottom capscrew

Replacing the Traction Belt

1. Raise the front of the machine and hold with jack stands.
2. Disconnect in-line wire connector from wire harness to electric clutch.
3. Remove mower drive belt; refer to mower Operator's Manual.
4. Remove left front engine mounting bolt securing clutch retainer to frame (Fig. 30). Unhook retainer from clutch and remove retainer.
5. Unhook tension spring from side of frame (Fig. 30).
6. Loosen pivot bolt enough to remove traction belt from the drive pulley and clutch.
7. Install new belt around clutch and drive pulley.
8. Torque pivot bolt to 35-40 ft. lb. (47-54 N.m). Install tension spring between idler arm and frame bracket (Fig. 30).
9. Hook clutch retainer into clutch and secure to frame with engine mounting bolt. Torque engine mounting bolt to 170-220 in. lb. (19-24 N.m).
10. Connect clutch in-line wire connector to wire harness.

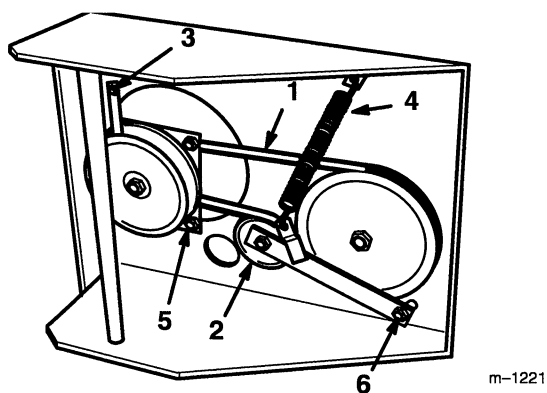

Figure 30

- | | |
|--------------------|-------------------|
| 1. Traction belt | 4. Tension spring |
| 2. Idler pulley | 5. Adjusting nut |
| 3. Clutch retainer | 6. Pivot bolt |

Adjusting the Electric Clutch

The clutch is adjustable to ensure proper engagement and proper braking. Check adjustment after every 100 hours of operation.

1. To adjust clutch, tighten or loosen lock nuts on flange studs (Fig. 30).
2. Check adjustment by inserting feeler gauge thru slots next to studs.
3. The proper disengaged clearance between the clutch plates is .012-.018 in. (0.30-0.45 mm). It will be necessary to check this clearance at each of the three slots to ensure the plates are parallel to each other.

Wiring Diagram

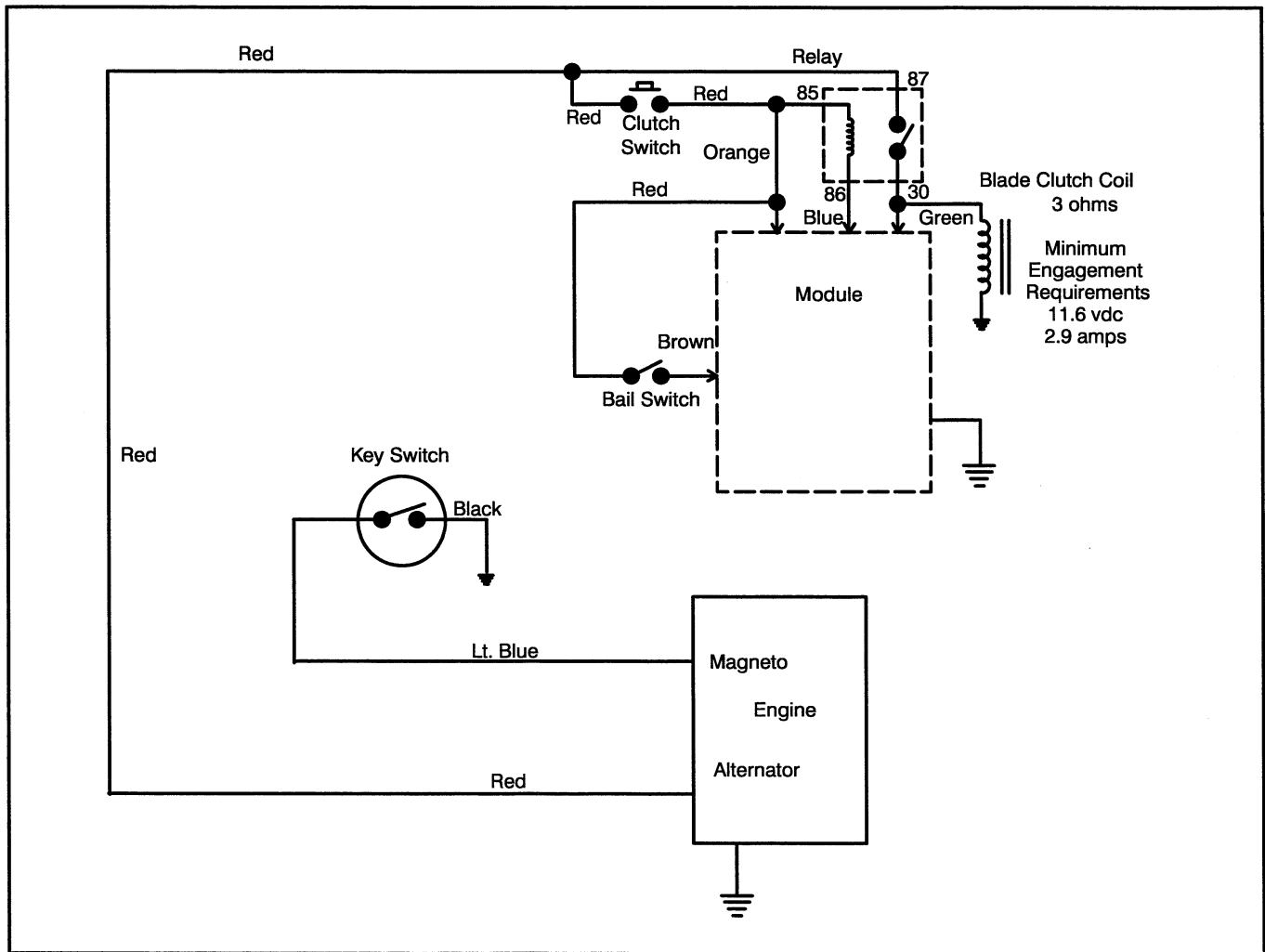

Cleaning and Storage

1. Disengage the power take off (PTO), set the parking brake, and turn the ignition key to "OFF" to stop the engine. Remove the key.
2. Remove grass clippings, dirt, and grime from the external parts of the entire machine, especially the engine. Clean dirt and chaff from the outside of the engine's cylinder head fins and blower housing.

IMPORTANT: You can wash the machine with mild detergent and water. Do not pressure wash the machine. Avoid excessive use of water, especially near the control panel, and engine.

3. Check the brake; refer to Brake, page 26.
4. Service the air cleaner; refer to Air Cleaner, page 20.
5. Grease the machine; refer to Greasing and Lubrication, page 24.
6. Change the crankcase oil; refer to Engine Oil, page 21.
7. Remove the spark plug(s) and check its condition; refer to Spark Plug, page 23. With the spark plug(s) removed from the engine, pour two tablespoons of engine oil into the spark plug hole. Now use the starter to crank the engine and distribute the oil inside the cylinder. Install the spark plug(s). Do not install the wire on the spark plug(s).
8. Check the tire pressure; refer to Tire Pressure, page 25.

9. During long-term storage, either drain gasoline from the fuel tank (step 10) or add a fuel stabilizer/conditioner additive to a full tank of gasoline (step A).
10. Drain gasoline from the fuel tank; refer to Fuel Tank, page 27. After fuel is drained, start the engine and let it idle until all gasoline is consumed and the engine stops. This eliminates gum-like buildup in the fuel system, which causes hard starting. Try to start the engine two more times to assure that no gasoline is in the fuel system.
 - A. Add the correct amount of a fuel stabilizer/conditioner or an isopropyl-based stabilizer/conditioner to a full tank of gasoline.

Note: Stabilizer/conditioners normally preserve gasoline for six to eight months.

11. Check and tighten all bolts, nuts, and screws. Repair or replace any part that is damaged or defective.
12. Paint all scratched or bare metal surfaces. Paint is available from your Authorized Service Dealer.
13. Store the machine in a clean, dry garage or storage area. Remove the key from the ignition switch and keep it in a memorable place. Cover the machine to protect it and keep it clean.

Troubleshooting

PROBLEM	POSSIBLE CAUSES	CORRECTIVE ACTION
Engine will not start, starts hard, or fails to keep running.	<ol style="list-style-type: none"> 1. Fuel tank is empty. 2. Choke is not ON. 3. Air cleaner is dirty. 4. Spark plug wire is loose or disconnected. 5. Spark plug is pitted, fouled, or gap is incorrect. 6. Dirt in fuel filter. 7. Dirt, water, or stale fuel is in fuel system. 	<ol style="list-style-type: none"> 1. Fill fuel tank with gasoline. 2. Move choke lever to ON. 3. Clean or replace air cleaner element. 4. Install wire on spark plug. 5. Install new, correctly gapped spark plug. 6. Replace fuel filter. 7. Contact Authorized Service Dealer.
Engine loses power.	<ol style="list-style-type: none"> 1. Engine load is excessive. 2. Air cleaner is dirty. 3. Oil level in crankcase is low. 4. Cooling fins and air passages under engine blower housing are plugged. 5. Spark plug is pitted, fouled, or gap is incorrect. 6. Vent hole in fuel cap is plugged. 7. Dirt in fuel filter. 8. Dirt, water, or stale fuel is in fuel system. 	<ol style="list-style-type: none"> 1. Reduce ground speed. 2. Clean air cleaner element. 3. Add oil to crankcase. 4. Remove obstruction from cooling fins and air passages. 5. Install new, correctly gapped spark plug. 6. Clean or replace the fuel cap. 7. Replace fuel filter. 8. Contact Authorized Service Dealer.
Engine overheats.	<ol style="list-style-type: none"> 1. Engine load is excessive. 2. Oil level in crankcase is low. 3. Cooling fins and air passages under engine blower housing are plugged. 	<ol style="list-style-type: none"> 1. Reduce ground speed. 2. Add oil to crankcase. 3. Remove obstruction from cooling fins and air passages.
Abnormal vibration.	<ol style="list-style-type: none"> 1. Engine mounting bolts are loose. 2. Loose engine pulley, idler pulley, or blade pulley. 3. Engine pulley is damaged. 	<ol style="list-style-type: none"> 1. Tighten engine mounting bolts. 2. Tighten the appropriate pulley. 3. Contact Authorized Service Dealer.

PROBLEM	POSSIBLE CAUSES	CORRECTIVE ACTION
Machine does not drive.	<ol style="list-style-type: none">1. Shift lever is in NEUTRAL.2. Traction belt is worn, loose or broken.3. Traction belt is off pulley.	<ol style="list-style-type: none">1. Move shift lever to a drive gear position.2. Change Belt.3. Change Belt.



ProLine
Products

THE TORO TOTAL COVERAGE GUARANTEE

A One Year Limited Warranty
(A Full Two-Year Warranty for Residential Use)

What Is Covered By This Express Warranty?

The Toro Company promises to repair any TORO ProLine product used for commercial, institutional, or rental purposes if defective in materials or workmanship for a period of one year from the date of purchase. The cost of parts and labor are included as well as transportation within a 15 mile radius of a TORO ProLine Service Dealer.

What Products Are Covered By This Warranty?

ProLine products covered by this warranty include the ProLine 118, 120, 220, 616, 620, 724 riding products and wide area walk behind mowers and their cutting decks and accessories.

How About Residential Use?

TORO ProLine products used for residential use are covered by a full two-year warranty.

How Do You Get Warranty Service?

Should you feel your TORO ProLine product contains a defect in materials or workmanship, contact the dealer who sold you the product or any TORO ProLine Service Dealer. The Yellow Pages of your telephone directory is a good reference source; look under TORO Commercial Service Dealers. The Service Dealer will either arrange service at his/her dealership or recommend another authorized Service Dealer who may be more convenient. You may need proof of purchase (copy of registration card, sales receipt, etc.) for warranty validation.

If for any reason you are dissatisfied with a Service Dealer's analysis of the defect in materials or workmanship or if you need a referral to a TORO ProLine Service Dealer, please feel free to contact us at the following address:

Toro Customer Service Department
8111 Lyndale Avenue South
Bloomington, MN 55420-1196
612-888-8801

What Must You Do To Keep The Warranty In Effect?

You must maintain your TORO Product by following the maintenance procedures described in the operator's manual. Such routine maintenance, whether performed by a dealer or by you, is at your expense.

What Does This Warranty Not Cover? and

How Does Your State Law Relate To This Warranty?

There is no other express warranty except as described above. This express warranty does not cover:

- Cost of regular maintenance service or parts, such as filters, fuel, lubricants, tune-up parts, blade sharpening, brake and clutch adjustments.
- Any product or part which has been altered or misused or required replacement or repair due to normal wear, accidents, or lack of proper maintenance.
- Repairs necessary due to improper fuel, contaminants in the fuel system, or failure to properly prepare the fuel system prior to any period of non-use over three months.
- Pickup and delivery charges for distances beyond a 15 mile radius from a TORO ProLine Service Dealer.

All repairs covered by this warranty must be performed by a TORO Service Dealer using Toro approved replacement parts.

Repair by a TORO Service Dealer is your sole remedy under this warranty.

The Toro Company is not liable for indirect, incidental or consequential damages in connection with the use of the TORO Products covered by this warranty, including any cost or expense of providing substitute equipment or service during reasonable periods of malfunction or non-use pending completion of repairs under this warranty. Some states do not allow exclusions of incidental or consequential damages, so the above exclusion may not apply to you.

This warranty gives you specific legal rights, and you may also have other rights which vary from state to state.

COUNTRIES OTHER THAN THE UNITED STATES OR CANADA

Customers who have purchased TORO products exported from the United States or Canada should contact their TORO Distributor (Dealer) to obtain guarantee policies for your country, province, or state. If for any reason you are dissatisfied with your Distributor's service or have difficulty obtaining guarantee information, contact the TORO importer. If all other remedies fail, you may contact us at The Toro Company.