



**ProLine Mid-Size
14 HP Hydro
Traction Unit**

Model No. 30187 – 790001 & Up

Operator's Manual

IMPORTANT: Read this manual carefully. It contains information about your safety and the safety of others. Also become familiar with the controls and their proper use before you operate the product.

Introduction

Thank you for purchasing a Toro product.

All of us at Toro want you to be completely satisfied with your new product, so feel free to contact your local Authorized Service Dealer for help with service, genuine replacement parts, or other information you may require.

Whenever you contact your Authorized Service Dealer or the factory, always know the model and serial numbers of your product. These numbers will help the Service Dealer or Service Representative provide exact information about your specific product. You will find the model and serial number plate located in a unique place on the product as shown below.

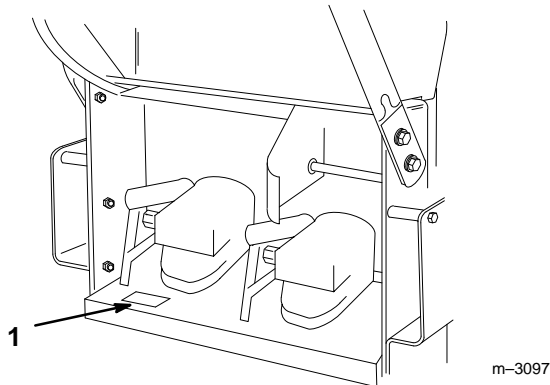

1. Model and Serial Number Plate

For your convenience, write the product model and serial numbers in the space below.

Model No: _____
Serial No. _____

Read this manual carefully to learn how to operate and maintain your product correctly. Reading this manual will help you and others avoid personal injury and damage to the product. Although we design, produce and market safe, state-of-the-art products, you are responsible for using the product properly and safely. You are also responsible for training persons, who you allow to use the product, about safe operation.

The warning system in this manual identifies potential hazards and has special safety messages that help you and others avoid personal injury, even death. **DANGER**, **WARNING** and **CAUTION** are signal words used to identify the level of hazard. However, regardless of the hazard, be extremely careful.

DANGER signals an extreme hazard that will cause serious injury or death if the recommended precautions are not followed.

WARNING signals a hazard that may cause serious injury or death if the recommended precautions are not followed.

CAUTION signals a hazard that may cause minor or moderate injury if the recommended precautions are not followed.

Two other words are also used to highlight information. “Important” calls attention to special mechanical information and “Note” emphasizes general information worthy of special attention.

The left and right side of the machine is determined by sitting on the seat in the normal operator’s position.

!	WARNING:	!
The engine exhaust from this product contains chemicals known to the State of California to cause cancer, birth defects, or other reproductive harm.		

Contents

	Page		Page
Safety	2	Neutral	19
Safe Operating Practices	2	Stopping the Machine	19
Slope Chart	5	Pushing the Machine by Hand	20
Safety and Instruction Decals	7	Maintenance	21
Gasoline and Oil	8	Service Interval Chart	21
Recommended Gasoline	8	Air Cleaner	22
Stabilizer/Conditioner	8	Engine Oil	23
Filling the Fuel Tank	8	Spark Plug	25
Check Engine Oil Level	8	Cleaning the Cooling Systems	26
Assembly	9	Tire Pressure	27
Loose Parts	9	Fuse	27
Install Wheels	10	Fuel Tank	28
Install Upper Handle	10	Fuel Filter	29
Install Control Rods	11	Hydraulic System	29
Activate the Battery	13	Adjusting By-pass Valve	31
Install Battery	14	Replacing the Traction Belt	33
Operation	15	Adjusting the Electric Clutch	33
Think Safety First	15	Adjusting Neutral	34
Controls	15	Battery	35
Starting and Stopping the Engine	16	Wiring Diagram	36
Operating Mower Blade Control (PTO) ..	17	Hydraulic Diagram	37
The Safety Interlock System	17	Cleaning and Storage	38
Driving Forward or Backward	18	Troubleshooting	39
		Warranty	Back Cover

THE ENCLOSED ENGINE OWNER'S MANUAL IS SUPPLIED FOR CALIFORNIA EMISSION CONTROL REGULATION INFORMATION ON EMISSION SYSTEMS, MAINTENANCE AND WARRANTY.

KEEP THIS ENGINE OWNER'S MANUAL WITH YOUR UNIT. SHOULD THIS ENGINE OWNER'S MANUAL BECOME DAMAGED OR ILLEGIBLE, REPLACE IMMEDIATELY. REPLACEMENTS MAY BE ORDERED THROUGH THE ENGINE MANUFACTURER.

Safety

This machine meets or exceeds safety requirements B71.4–1990 of the American National Standards Institute for commercial mowers, in effect at time of production. However, improper use or maintenance by the operator or owner can result in injury. To reduce the potential for injury, comply with these safety instructions and always pay attention to the safety alert  symbol which means CAUTION, WARNING or DANGER—“personal safety instruction.” Failure to comply with the instruction may result in personal injury.

Safe Operating Practices

This product is capable of amputating hands and feet and throwing objects. Always follow all safety instructions to avoid serious injury or death.

WARNING

POTENTIAL HAZARD

- **Engine exhaust contains carbon monoxide, which is an odorless, deadly poison.**

WHAT CAN HAPPEN

- **Carbon monoxide can kill you and is also known to the State of California to cause birth defects.**

HOW TO AVOID THE HAZARD

- **Do not run engine indoors or in an enclosed area.**

This mower is designed for cutting and recycling grass or, when equipped with a grass bag, for catching cut grass. Any use for purposes other than these could prove dangerous to user or bystanders.

Note: This engine is NOT equipped with a spark arrester muffler. Use or operation of this mower in the State of California on any forest-covered, brush-covered or unimproved grass-covered land, without an approved spark arrester muffler, is a violation of the law. Other states may have similar laws.

General Operation

1. Read this manual carefully before operating the mower. Become familiar with the controls and proper use of the mower. Never allow children under 16 years of age to operate the mower. Never allow adults to operate mower without proper instructions.
2. The operator of the mower is responsible for keeping everyone, especially children and pets, away from area of operation. The operator is responsible for accidents or hazards occurring to other people or their property.
3. Thoroughly inspect area where mower will be used and remove sticks, stones, wire, and debris that could be picked up and thrown by mower. Watch for foreign objects while mowing.
4. Wear long pants and substantial shoes. Do not operate mower while wearing open-toed shoes, jewelry, loose clothing or when barefoot.
5. Check fuel level before starting engine. Because fuel is highly flammable, handle it carefully.
 - A. Use an approved fuel container.
 - B. Fill fuel tank outdoors, not indoors.
NEVER ADD FUEL TO AN ENGINE THAT IS RUNNING OR HOT.
 - C. Install gas cap on fuel container and gas tank, and wipe up any spilled gasoline before starting engine.

D. Do not smoke while refueling.

6. Keep all guards, shields, safety devices, cover-deflector assembly, optional grass catcher, optional side discharge chute or optional discharge tunnel plug in place. Repair or replace damaged parts, including decals. Check all safety devices before each use.
7. Engine, blade and self-propelled drive (self-propelled model) are designed to stop when control bails are released. Ensure control and brake function properly before each use of mower.
8. Disengage the self-propelled mechanism or drive clutch (self-propelled model) before starting the engine.
9. Before using, always visually inspect to see that the blades, blade fasteners and cutter assembly are not worn or damaged. Replace worn or damaged blades and fasteners in sets to preserve balance.

While Operating

1. Do not run engine indoors.
2. Start the engine carefully according to instructions and with feet well away from the blade.
3. Always maintain secure footing. Keep a firm grip on the handle and walk; never run. Never operate mower in wet grass. Mow only in daylight or in good artificial light.
4. Mow across the face of slopes; never up and down. Use extreme caution when changing direction on slopes. Do not mow excessively steep slopes. Wear skid resistant shoes on slopes.
5. Always wear safety glasses or eye shields during operation to protect eyes from foreign objects that may be thrown from the machine.
6. Keep face, hands, and feet away from the mower housing and cutter blade when the engine is running. Blade can cause injury to hands and feet. Stay behind the handle until the engine stops.
7. Use extreme caution when reversing or pulling the mower towards you.
8. Since the blade rotates for a few seconds after the control bar is released, stay behind the handle until all moving parts stop.
9. After striking a foreign object or if mower vibrates abnormally, stop engine and remove wire from spark plug. Check mower for damage and make all repairs before using mower again. If major repairs are ever needed or if assistance is desired, contact your local Authorized TORO Service Dealer.
10. Stop the engine and wait for all moving parts to stop before adjusting the height-of-cut.
11. Stop the blade when pushing the mower outside the lawn area.
12. Stop engine before leaving the operator's position—behind the handle. Disconnect wire from spark plug if mower will be unattended.
13. Do not touch engine while it is running or shortly after it is stopped because engine will be hot enough to cause a burn.
14. Refuel only when engine is cool.
15. If mower must be lifted to be transported, turn off engine and stay behind the handle until all moving parts stop. Disconnect spark plug wire.

Maintenance And Storage

1. Perform only those maintenance instructions described in this manual. If major repairs are ever needed or if assistance is desired, contact your local Authorized TORO Service Dealer.
2. Before mower is cleaned, inspected, serviced, or adjusted, stop engine and disconnect wire from spark plug. Keep wire away from plug to prevent accidental starting.
3. To ensure the mower is in safe operating condition, frequently check and keep all nuts, bolts, and screws tight. Ensure blade bolt is tightened to 85–110 ft-lb (115–149 N·m).
4. When servicing blade, refer to blade maintenance section for correct installation and servicing procedures.
5. To reduce fire hazard, keep engine free of excessive grease, grass, leaves, and accumulations of dirt.
6. Allow engine to cool before storing mower in any enclosure. Do not store mower with gasoline in fuel tank near any open flame or where gasoline fumes may be ignited by a spark.
7. Do not overspeed the engine by changing governor settings.
8. At the time of manufacture, the mower conformed to the safety standards in effect for rotary mowers. To assure best performance and continued safety certification of the mower, use genuine TORO replacement parts and accessories. Replacement parts and accessories made by other manufacturers may result in non-conformance with the safety standards, and that could be dangerous.

Slope Chart

Read all safety instructions on pages 2-7.

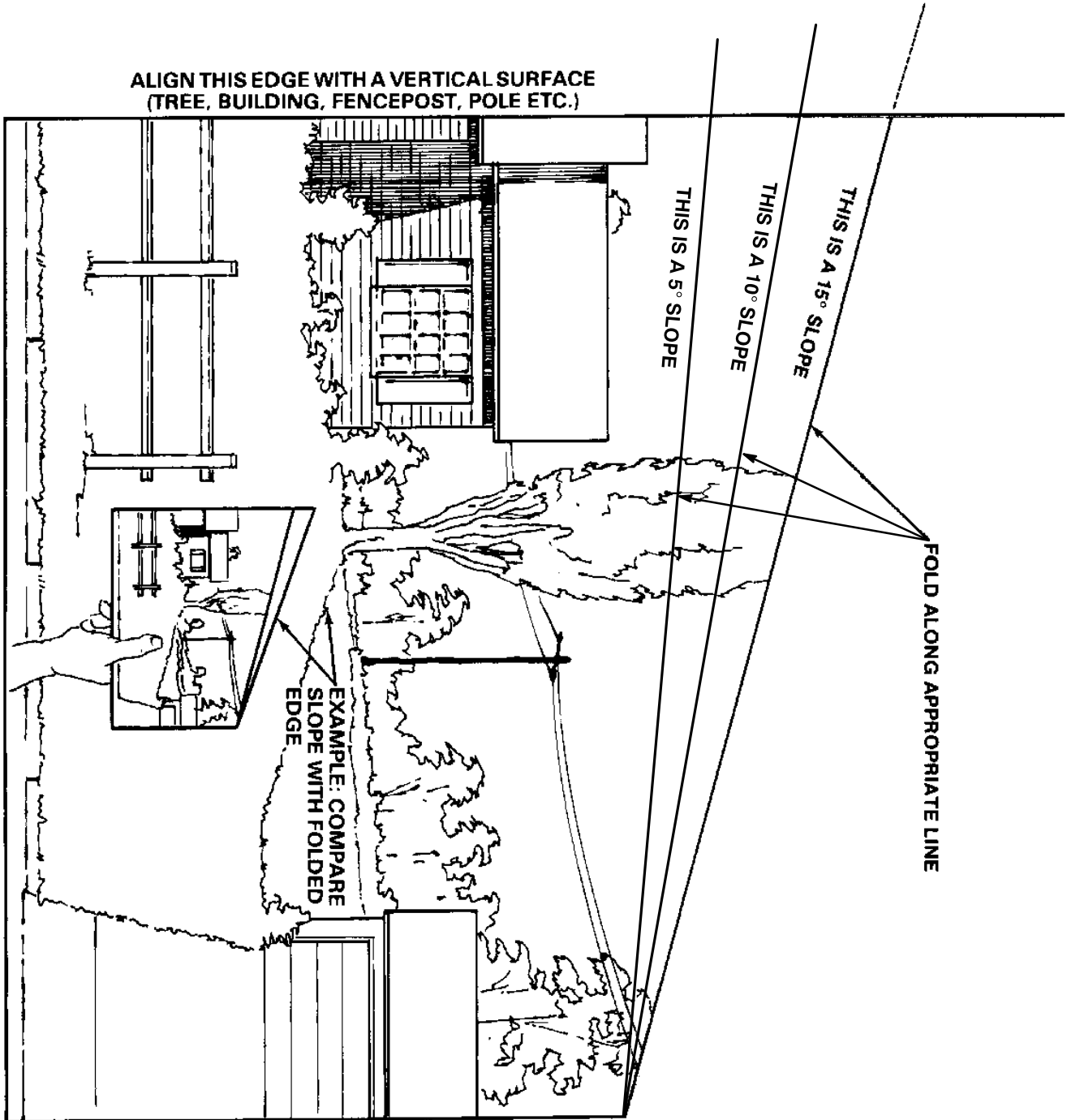

Safety and Instruction Decals



Safety decals and instructions are easily visible to the operator and are located near any area of potential danger. Replace any decal that is damaged or lost.

ON CONTROL PANEL (Part No. 95-1544)

⚠ DANGER AVOID SERIOUS INJURY or DEATH:
• GO ACROSS SLOPES, NOT UP AND DOWN.

- DO NOT MOW WHEN CHILDREN OR OTHERS ARE AROUND.
- LOOK DOWN AND BEHIND BEFORE AND WHILE MOVING BACKWARDS.
- KEEP SAFETY DEVICES (GUARDS, SHIELDS, ETC.) IN PLACE & WORKING.
- REMOVE OBJECTS THAT COULD BE THROWN BY THE BLADE.
- READ THE OPERATOR'S MANUAL FOR REPLACEMENT

MANUAL, SEND MODEL AND SERIAL NUMBER TO:
THE TORO CO., 8111 LYNDALE AVE. S., BLOOMINGTON, MN 55420-1196

ON CONTROL PANEL (Part No. 95-5859)

CHOKEN
FAST ←

SLOW →

OFF

RUN

START

ENGINE SPEED 95-5859

IGNITION

BLADE ENGAGEMENT

ON SIDE OF HANDLE (Part No. 95-5862)

95-5862

ON OIL COOLER (Part No. 95-2814)

IMPORTANT

TO CLOSE VALVE:
ROTATE KNOB
CLOCKWISE UNTIL
IT STOPS.

95-2814

ON SWITCH PLATE (Part No. 95-1523)

↑ FORWARD

TRACTION DRIVE

↓ REVERSE

95-1523

ON FRAME NEXT TO HYDRO PUMPS (Part No. 95-1543)

PRESSURE VALVE ADJUSTMENT

LOOSEN JAM NUT AND GENTLY CLOSE VALVE. OPEN VALVE 1/2 TURN AND LOCK THE ADJUSTMENT BY TIGHTENING THE JAM NUT.

SEE OPERATOR'S MANUAL FOR DETAILED PROCEDURE

95-1543

ON UPPER HANDLE (Part No. 82-4590)

⚠ CAUTION

- DRIVE SYSTEM MAY NOT HOLD MACHINE IF PARKED ON SLOPE.
- MOVEMENT OF AN UNATTENDED MACHINE CAN CAUSE PROPERTY DAMAGE OR PERSONAL INJURY.
- WHEELS MUST BE BLOCKED IF MACHINE IS PARKED ON SLOPE.
- WHEN POSSIBLE, PARK MACHINE ON LEVEL SURFACE.

82-4590

ON LEFT SIDE OF ENGINE (Part No. 63-8440)

⚠ WARNING

HOT

↓

63-8440

Gasoline and Oil

Recommended Gasoline

Use UNLEADED Regular Gasoline suitable for automotive use (85 pump octane minimum). Leaded regular gasoline may be used if unleaded regular is not available.

IMPORTANT: Never use methanol, gasoline containing methanol, or gasohol containing more than 10% ethanol because the fuel system could be damaged. Do not mix oil with gasoline.

DANGER

POTENTIAL HAZARD

- In certain conditions gasoline is extremely flammable and highly explosive.

WHAT CAN HAPPEN

- A fire or explosion from gasoline can burn you, others, and cause property damage.

HOW TO AVOID THE HAZARD

- Use a funnel and fill the fuel tank outdoors, in an open area, when the engine is cold. Wipe up any gasoline that spills.
- Do not fill the fuel tank completely full. Add gasoline to the fuel tank until the level is 1/4" to 1/2" (6 mm to 13 mm) below the bottom of the filler neck. This empty space in the tank allows gasoline to expand.
- Never smoke when handling gasoline, and stay away from an open flame or where gasoline fumes may be ignited by a spark.
- Store gasoline in an approved container and keep it out of the reach of children. Never buy more than a 30-day supply of gasoline.

Stabilizer/Conditioner

Add the correct amount of gas stabilizer/conditioner to the gas. Using a stabilizer/conditioner in the machine:

- Keeps gasoline fresh during storage
- Cleans the engine while it runs
- Eliminates gum-like buildup in the fuel system, which causes hard starting

IMPORTANT: Never use fuel additives containing methanol or ethanol.

Filling the Fuel Tank

1. Shut the engine off.
2. Clean around the fuel tank cap and remove the cap. Use a funnel and add unleaded regular gasoline to the fuel tank, until the level is 1/4 to 1/2 inch (6 mm to 13 mm) below the bottom of the filler neck. This space in the tank allows gasoline to expand. Do not fill the fuel tank completely full.
3. Install the fuel tank cap securely. Wipe up any gasoline that may have spilled.

Check Engine Oil Level

Before you start the engine and use the machine, check the oil level in the engine crankcase; refer to Checking Oil Level, page 24.

Assembly

Loose Parts

Note: Use the chart below to verify all parts have been shipped.

DESCRIPTION	QTY.	USE
Wheel	2	Install drive wheels
Nut	8	
Upper handle	1	Install upper handle to frame
Flanged bolt 3/8–16 x 1" (26 mm)	4	
Flange nut 3/8–16	4	
Clevis pin	1	Install control rods
Washer	1	
Hairpin cotter	2	
Battery	1	Install battery
Battery holder	2	
Battery pad	2	
Bolt 3/8–16 x 1-3/4" (44 mm)	2	
Locknut 3/8–16	2	
Battery strap	1	
Battery support rod	2	
Locknut 1/4–20	2	
Carriage bolt 1/4–20 x 3/4" (19 mm)	2	
Nut 1/4–20	2	
Terminal boot	2	
Flange bolt 1/2–13 x 1-1/4" (32 mm)	4	Replace (6) 1/2–13 x 1" (26 mm) flange bolts supplied with mowers
Flange bolt 1/2–13 x 1-3/4" (44 mm)	2	
Hydraulic filter	1	Use for initial hydraulic filter change
Operator's Manual	1	Read before operating machine
Engine Operator's Manual	1	
Parts Catalog	1	
Registration card	1	
		Fill out and return to Toro

Install Wheels

1. Mount wheels to wheel motor hubs with (8) lug nuts (Fig. 1). Torque bolts to 55 ft. lbs. (75 N·m).

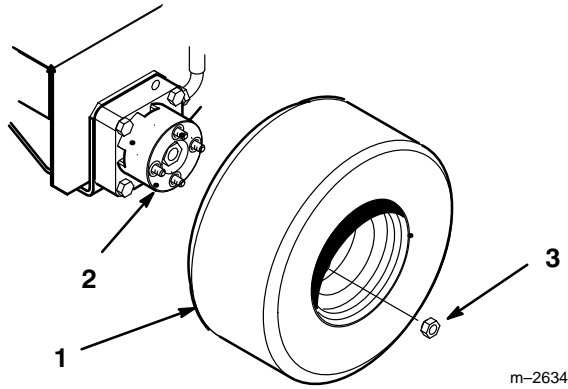

Figure 1

1. Wheel
2. Hub
3. Lug nut

Install Upper Handle

1. Align upper handle with mounting holes in rear frame (Fig. 2). Select high, medium or low position for lower mounting hole.
2. Secure each side with (2) 3/8–16 x 1" (26mm) flange bolts and flange nuts (Fig. 2). Torque bolts to 25 ft. lbs. (34 N·m).

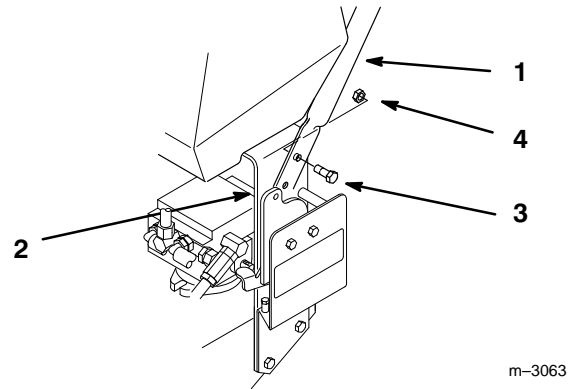

Figure 2

1. Upper handle
2. Rear frame
3. Flange bolt 3/8–16 x 1" (26mm)
4. Flange nut 3/8"

Install Control Rods

Before installing and adjusting control rods loosen quick release levers and move reference control bar all the way forward.

Left Control Rod

1. Slide clevis pin through rod fitting and mounting hole in control bracket (from outside). Secure with washer and hairpin cotter (Fig. 3).
2. Remove hairpin cotter and rod from upper control bars.
3. Press and hold upper control bars against reference bar, so stop hits.
4. Push rod full forward until bearing is against control bracket stop. Thread rod in or out of fitting on control bracket until rod aligns with holes in upper control bars (Fig. 3).
5. When rod and holes in upper control bars line up, turn rod one (1) additional turn, so rod is shorter.

Note: Upper control bar stop must hit reference bar before roller hits control bracket stop.

6. Connect rod to upper control bars with previously removed hairpin cotter.

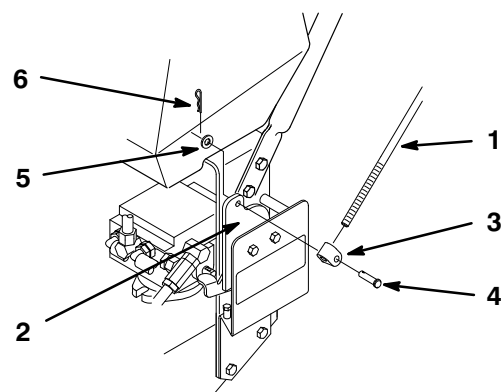

m-3064

Figure 3

- | | |
|---------------------|-------------------|
| 1. Control rod-left | 4. Clevis pin |
| 2. Control bracket | 5. washer |
| 3. Rod fitting | 6. Hairpin cotter |

Right Control Rod

7. Slide rod into control bracket and secure with hairpin cotter (Fig. 4).
8. Remove hairpin cotter and rod from upper control bars.
9. Press and hold upper control bars against reference bar, so stop hits.
10. Push rod full forward until bearing is against control bracket stop. Loosen wing nut and thread turnbuckle in or out until rod aligns with holes in upper control bars (Fig. 3).
11. When rod and holes in upper control bars line up, rotate turnbuckle one (1) additional turn, so rod is shorter.

Note: Upper control bar stop must hit reference bar before roller hits control bracket stop.

12. Connect rod to upper control bars with previously removed hairpin cotter, tighten wing nut and turnbuckle.

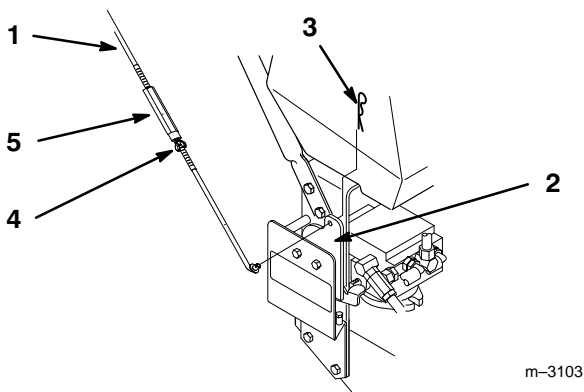

Figure 4

- | | |
|----------------------|---------------|
| 1. Control rod-right | 4. Wing nut |
| 2. Control bracket | 5. Turnbuckle |
| 3. Hairpin cotter | |

Adjust Tracking

13. After completing assembly check machine tracking. Operate machine by holding upper control bar against reference bar with wheel drive engaged.
14. If machine does not track straight, moves more right or left, adjustment is required.
15. Loosen wing nut on right control rod and rotate turnbuckle in or out to change tracking. Secure turnbuckle in position with wing nut (Fig. 4).
16. Check for proper tracking.

Note: Control rods must be adjusted if handle height position is changed.

Activate the Battery

Bulk electrolyte with 1.260 specific gravity must be purchased from a local battery supply outlet.

1. Remove the battery from the machine.

IMPORTANT: Be careful not to damage the long vent tube when removing the battery.

DANGER

POTENTIAL HAZARD

- Battery electrolyte contains sulfuric acid which is a deadly poison and it causes severe burns.

WHAT CAN HAPPEN

- If you carelessly drink electrolyte you could die or if it gets onto your skin you will be burned.

HOW TO AVOID THE HAZARD

- Do not drink electrolyte and avoid contact with skin, eyes or clothing. Wear safety glasses to shield your eyes and rubber gloves to protect your hands.
- Fill the battery where clean water is always available for flushing the skin.
- Follow all instructions and comply with all safety messages on the electrolyte container.

2. Remove filler caps from the battery. Slowly pour electrolyte into each cell until the electrolyte level is up to the lower part of the tube (Fig. 5).

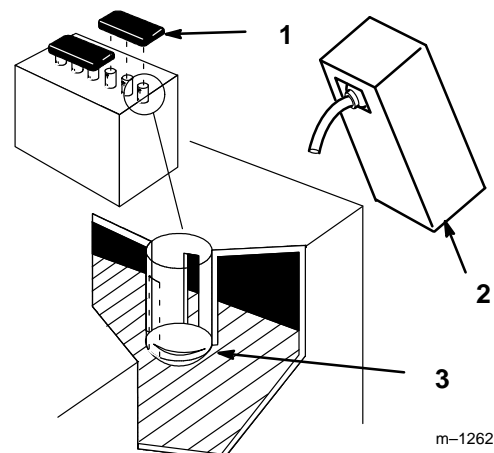

Figure 5

1. Filler caps
2. Electrolyte
3. Lower part of the tube

3. Leave the covers off and connect a 3 to 4 amp battery charger to the battery posts (Fig. 6). Charge the battery at a rate of 4 amperes or less for 4 hours (12 volts).

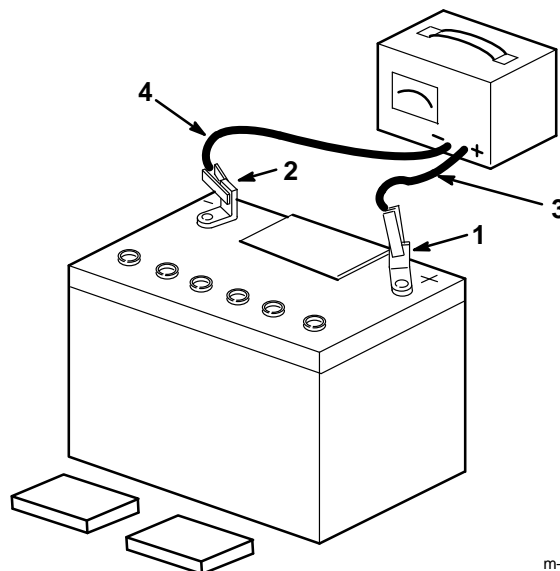

Figure 6

1. Positive post
2. Negative post
3. Charger red (+) wire
4. Charger black (-) wire

WARNING

POTENTIAL HAZARD

- Charging battery produces gasses.

WHAT CAN HAPPEN

- Battery gasses can explode.

HOW TO AVOID THE HAZARD

- Keep cigarettes, sparks and flames away from battery.

4. When the battery is fully charged, disconnect the charger from the electrical outlet then from the negative and positive battery posts (Fig. 6).
5. Slowly pour electrolyte into each cell until the level is once again up to the "UPPER" line on the battery case (Fig. 5) and install covers.

Install Battery

1. Mount battery holders to back side of left rear corner of cutting unit carrier frame with (2) 3/8-16 x 1-3/4" bolts and 3/8" locknuts (Fig. 7).
2. Peel off backing from battery pads and affix pads to battery holder, positioning as shown in Fig. 6.
3. Fill battery with electrolyte and charge, refer to BATTERY, page 35.

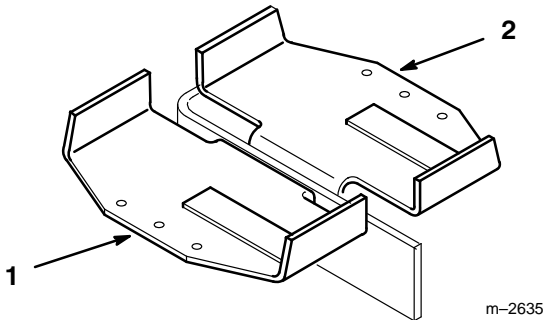

Figure 7

1. Battery holder
2. Battery pads

4. Position battery onto holder with terminal posts away from the engine (Fig. 8).
5. Slide the red terminal boot onto the red battery cable and the black terminal boot onto the the black battery cable.
6. Install the positive (red) battery cable to positive (+) battery terminal and the negative battery cable to the negative (-) battery terminal. Secure cables with (2) 1/4 x 3/4" (19 mm) carriage bolts and 1/4" locknuts.
7. Mount battery to holder with (2) support rods, a battery clamp and (2) 1/4" locknuts. Position support rods in mounting holes (Fig. 8). Tighten locknuts so battery is held securely in position and will not slide. **DO NOT OVERTIGHTEN.**
8. Slide vent tube through hole, next to support rod, in battery holder.

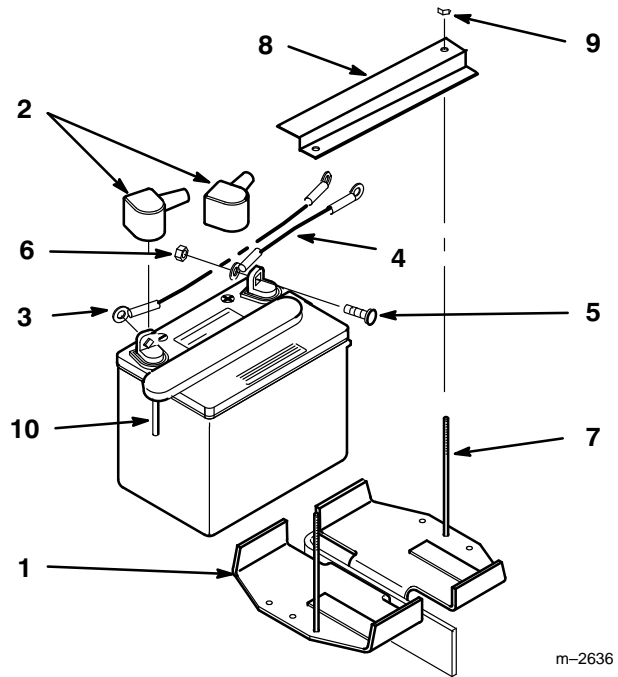

Figure 8

- | | |
|--|------------------------|
| 1. Battery holder | 6. Nut 1/4" |
| 2. Terminal boot | 7. Battery support rod |
| 3. Positive battery cable | 8. Battery clamp |
| 4. Negative battery cable | 9. Locknut 1/4" |
| 5. Carriage bolt 1/4-20 x 3/4" (19 mm) | 10. vent tube |

Operation

Think Safety First

Please carefully read all the safety instructions and symbols in the safety section. Knowing this information could help you, your family, pets or bystanders avoid injury.

Controls

Become familiar with all the controls (Fig. 9) before you start the engine and operate the machine.

Throttle Control – The throttle control has three positions: “FAST”, “SLOW” and “CHOKE”.

Blade Control Bail – Control bail used in conjunction with deck engagement switch (PTO) to release blade brake and engage clutch to drive mower blades. Release bail to disengage mower blades.

Blade Control Switch (PTO) – Rocker switch used in conjunction with control bail to release blade brake and engage clutch to drive mower blades.

Upper Control Bar – Push forward on control bar to engage forward traction operation, release to stop. Pull back on control bar to go backwards. Release either side of control bar to turn right or left.

Reference Handle – Limits forward travel of control bar to pre-set position to help maintain desired ground speed and direction of travel. It is locked in position with quick release levers.

Ignition Switch – Key switch is used with the electric starter. Switch has three positions: “START”, “RUN” and “OFF”.

Fuel Shut-off Valve – (Under fuel tank) Close fuel shut-off valve when transporting or storing mower.

Hour Meter – Shows total hours that machine has been operated. Only operates with ignition key in “ON” position.

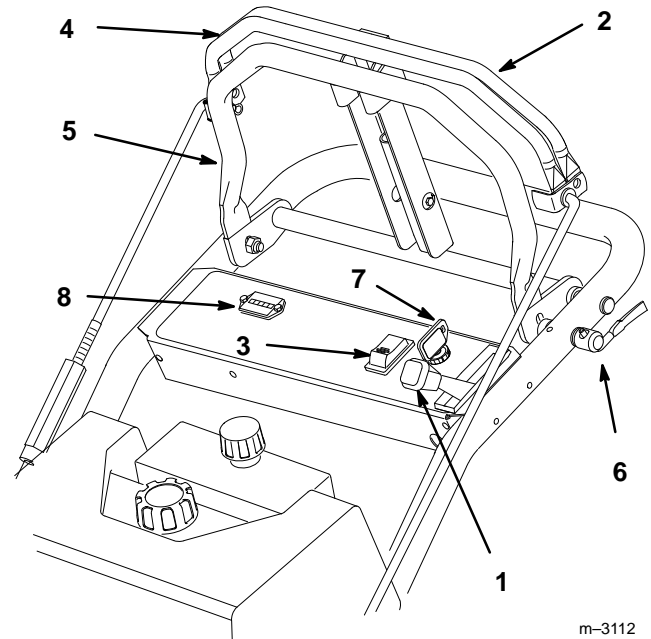

Figure 9

- | | |
|-------------------------------|------------------------|
| 1. Throttle control | 5. Reference handle |
| 2. Blade control bail | 6. Quick release lever |
| 3. Blade control switch (PTO) | 7. Ignition switch |
| 4. Upper control bar | 8. Hourmeter |

Starting and Stopping the Engine

Starting

1. Make sure spark plug wire(s) are installed on spark plug(s) and fuel valve is open.
2. Move the throttle control to “CHOKE” position before starting a cold engine.

Note: A warm or hot engine may require choking. After engine starts, move choke control to “RUN” position.

3. Turn ignition key “START” to energize starter. When engine starts, release key.

IMPORTANT: Do not engage starter for more than 10 seconds at a time. If engine fails to start allow 30 second cool-down period between attempts. Failure to follow these instructions can burn out starter motor.

4. When engine starts move the throttle control to the “FAST” position.

Stopping

1. Move the throttle lever to “SLOW” (Fig. 10).

Note: If the engine has been working hard or is hot, let it idle for a minute before turning the ignition key “OFF.” This helps cool the engine before it is stopped. In an emergency, the engine may be stopped by turning the ignition key to “OFF.”

2. Turn the ignition key to “OFF” (Fig. 10).

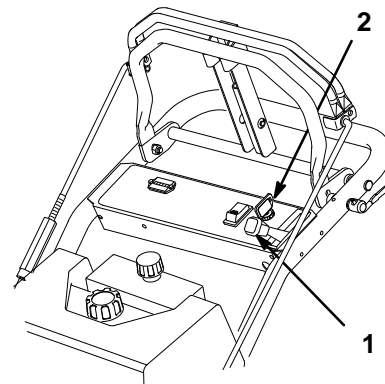

m-3112

Figure 10

1. Throttle lever
2. Ignition key

3. Pull wire off spark plug(s) to prevent possibility of accidental starting before transporting or storing machine.
4. Close fuel shut off valve, under fuel tank, before transporting or storing machine.

IMPORTANT: Make sure fuel shut off valve is closed before transporting or storing machine, as fuel leakage may occur.

Operating Mower Blade Control (PTO)

The blade control switch (PTO) in conjunction with the blade control bail engages and disengages power to the electric clutch and mower blades.

Engaging the Mower Blades (PTO)

1. Release the upper control bar to stop the machine (Fig. 11).
2. To engage blade, squeeze blade control bail against upper control bar (Fig. 11).
3. Press blade control (PTO) rocker switch forward and release. Hold blade control bail against control bar while operating.
4. Repeat procedure to engage mower blades if blade control bail is released.

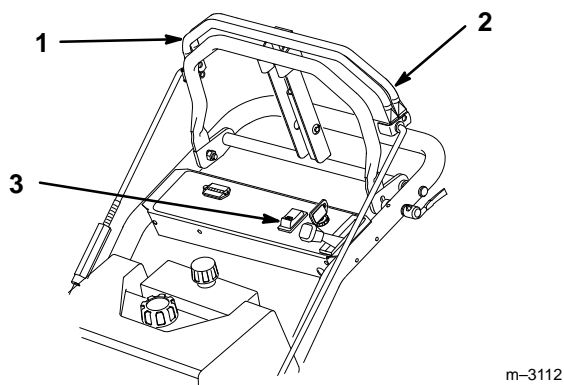

Figure 11

- | | |
|-----------------------|-------------------------------|
| 1. Upper control bar | 3. Blade control switch (PTO) |
| 2. Blade control bail | |

Disengaging the Mower Blades (PTO)

1. Releasing blade control bail to disengage blades (Fig. 11).

The Safety Interlock System

Understanding the Safety Interlock System

The safety interlock system is designed to prevent the mower from starting unless the control bar is in the neutral position and to prevent the blades from rotating when the blade control is released.

Testing the Safety Interlock System

Test the safety interlock system before you use the machine each time. If the safety system does not operate as described below, have an Authorized Service Dealer repair the safety system immediately.

1. Set the machine on a flat, open area.
2. Push the control bar full forward.
3. Rotate the ignition key to "START" and slowly move control bar back to neutral. Engine should not crank until control bar is within 5° of neutral position.
4. Start the engine: refer to Starting and Stopping the Engine, page 16. With engine running and control bar in neutral position, squeeze control bail against control bar (Do not press deck engagement switch), clutch should not engage and blades must not rotate.
5. Continue holding the blade control bail and press the rocker switch forward "ON" and release. The clutch should engage and the mower blades begin rotating.
6. Release the blade control bail. The clutch must disengage and the blades stop rotating.
7. Release the blade control bail (PTO), then push the blade control switch (PTO) to "ON" without holding the blade control bail. The clutch must not engage and the blades must not rotate.
8. If all the above conditions are not met have an Authorized Service Dealer repair the safety system immediately.

Driving Forward or Backward

The Enhanced T-Bar control system is designed to provide easy and comfortable operation of the hydrostatic drive. The control regulates ground speed, as well as forward, reverse and neutral functions, as well as steering direction.

The throttle control regulates the engine speed as measured in rpm (revolutions per minute). Place the throttle control in the “FAST” position for best performance.

Operate the machine with the engine speed set at slow or medium when learning how to use the controls. Practice driving the machine in a level open area.

Ground Speed

1. Place the quick release levers in the unlock position (Fig. 12).
2. Move the reference bar forward or backward to desired forward speed. The pointer indicates approximate ground speed (Fig. 12). When the bar is in the full forward position the ground speed is approximately 6 mph. When the bar is in the middle position the ground speed is approximately 3 mph.

Note: In normal conditions, a 2.5 to 3.0 mph ground speed (middle position of the reference bar) is best for cutting performance. Use a faster ground speed for light cutting or transport. Use a slower ground speed in heavy cutting loads.

3. Place the quick release levers in the lock position (Fig. 12).

Forward

1. To go forward, slowly press on the upper control bar against the reference bar (Fig. 12).
2. To go straight, apply equal pressure to both ends of the upper control bar (Fig. 12).
3. To turn, release pressure on the upper control bar side toward the direction you want to turn (Fig. 12).
4. To go straight, apply equal pressure to both sides of the upper control bar.
5. Adjust reference handle to maintain a comfortable pre-set ground speed (Fig. 12).
6. To stop, release the upper control bar to stop both wheels (Fig. 12).

Note: If the front of the deck lifts off the ground when the upper control bar is quickly pushed forward or the machine is unable to drive uphill, an adjustment may be needed. Refer to: Adjusting By-pass Valve.

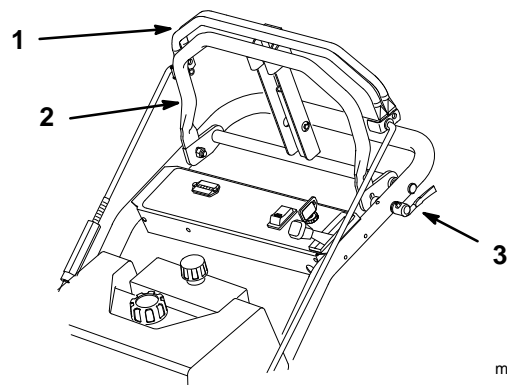

m-3112

Figure 12

1. Upper control bar
2. Reference control bar
3. Quick release lever

Backward

1. To go backward, slowly pull the control bar rearward (Fig. 12).
2. To go straight, apply equal pressure to both ends of the upper control bar (Fig. 12).
3. To turn, release pressure on the upper control bar side away from the direction you want to turn (Fig. 12).
4. To stop, release the upper control bar to stop both wheels (Fig. 12).

Neutral

Release the upper control bar to stop. The machine will automatically return to neutral. When in neutral, the hydrostatic drive system will provide dynamic braking so the machine will not roll.

Note: Very slow drive motion with engine running and the control in neutral is normal. Excessive drive motion when the control is in neutral may indicate adjustment is needed. Refer to: Adjusting Neutral procedure.

Stopping the Machine

1. To stop, release the upper control bar to stop both wheels (Fig. 12).
2. Release the blade control bail (PTO), to stop the mower blades. Move the engine speed throttle control to "SLOW".
3. Turn the ignition key to "OFF" to stop the engine. Remember to remove the key from the ignition switch.

IMPORTANT: If the machine is on a slope, block the wheels to prevent the machine from slowly rolling.

IMPORTANT: If the machine will be left unattended, close the fuel shut off valve and disconnect the wire(s) from the spark plug(s).

CAUTION

POTENTIAL HAZARD

- Someone could move or attempt to operate the machine while it is unattended.

WHAT CAN HAPPEN

- Children or bystanders may be injured if they use the machine.

HOW TO AVOID THE HAZARD

- Always remove the ignition key and set the parking brake when leaving the machine unattended, even if just for a few minutes.

IMPORTANT: If the machine is loaded on a truck or trailer for transport, securely restrain the machine to prevent movement.

CAUTION

POTENTIAL HAZARD

- Stopping, starting and turning may cause the machine to move or shift position during transport.
- Rough roads may cause the machine to fall off vehicle or trailer during transport.

WHAT CAN HAPPEN

- Children or bystanders may be injured.
- The machine may be damaged.
- Other property may be damaged.

HOW TO AVOID THE HAZARD

- Always restrain the machine securely before transporting.

Pushing the Machine by Hand

The by-pass valve also allows the machine to be pushed by hand with the engine not running for easier servicing. If the by-pass valve is opened to push the machine by hand, adjustment is required for operation.

IMPORTANT: Always push the machine by hand. Never tow the machine because hydraulic damage may occur.

To Push the Machine

1. Disengage the power take off (PTO) and turn the ignition key to “OFF” to stop the engine.
2. Loosen jam nuts and rotate by-pass valves open 5 turns to push. This allows hydraulic fluid to by-pass the pump and the wheels to turn (Fig. 13).

IMPORTANT: Rotate by-pass valve a maximum of 5 turns so the valve does not come out of the body causing fluid to run out.

To Operate the Machine

If the by-pass valve is opened to push the machine by hand, adjustment is required for operation. Refer to: “Adjusting By-pass Valve”.

Note: The machine will not drive unless by-pass valves are properly adjusted.

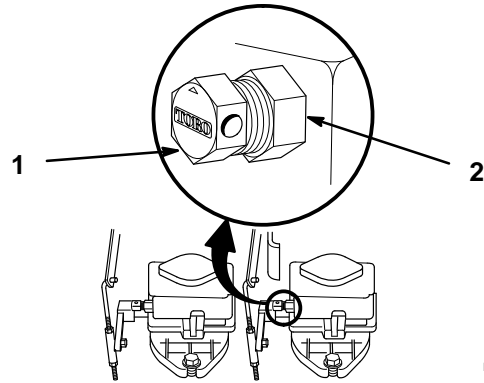

m-3098

Figure 13

1. By-pass valve

2. Jam nut

Maintenance

Service Interval Chart

Service Operation	Each Use	8 Hours	25 Hours	50 Hours	100 Hours	200 Hours	Storage Service
Hydraulic fluid—check level	Initial	X					X
Oil—check level	X						X
Oil—change*		Initial			X		X
Oil Filter—change (200 hours or every other oil change)						X	X
Hydraulic filter—change		Initial				X	X
Safety System—check	X						X
Foam Air Cleaner—service*			X				X
Paper Air Cleaner—replace*					X		X
Spark Plug(s)—check						X	X
Belts—check for wear/cracks				X			X
Electric Clutch—adjust					X		X
Gasoline—drain							X
Cooling systems—clean	X				X		X
Hydraulic lines—check					X		X
Battery—check electrolyte	X	X					X
Battery—charge, Disconnect cables							X
Fuel Filter—replace						X	X
Tires—check pressure				X			X
Chipped Surfaces—paint							X
* More often in dusty, dirty conditions							

CAUTION

POTENTIAL HAZARD

- If you leave the key in the ignition switch, someone could start the engine.

WHAT CAN HAPPEN

- Accidental starting of the engine could seriously injure you or other bystanders.

HOW TO AVOID THE HAZARD

- Remove the key from the ignition switch and pull the wire(s) off the spark plug(s) before you do any maintenance. Also push the wire(s) aside so it does not accidentally contact the spark plug(s).

Air Cleaner

Foam Element: Clean and re-oil after every 25 operating hours.

Paper Element: Replace after every 100 operating hours.

Note: Service the air cleaner more frequently (every few hours) if operating conditions are extremely dusty or sandy.

Removing the Foam and Paper Elements

1. Disengage the power take off (PTO) and turn the ignition key to "OFF" to stop the engine. Remove the key.
2. Clean around the air cleaner cover to prevent dirt from getting into the engine and causing damage. Unlatch cover (Fig. 14).
3. Carefully slide the foam element off the paper element (Fig. 14).
4. Remove the air cleaner assembly (Fig. 14).
5. Unscrew the cover nut and remove the cover and paper element (Fig. 14).

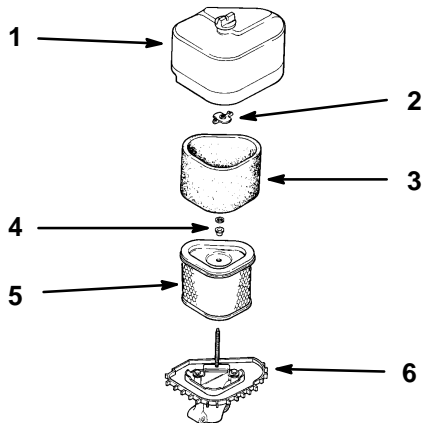

Figure 14

- | | |
|----------------------|---------------------|
| 1. Air cleaner cover | 4. Foam element |
| 2. Cover nut | 5. Paper element |
| 3. Cover | 6. Air cleaner base |

Cleaning the Foam and Paper Elements

1. Foam Element
 - A. Wash the foam element in liquid soap and warm water. When the element is clean, rinse it thoroughly.
 - B. Dry the element by squeezing it in a clean cloth.
 - C. Put one or two ounces of oil on the element (Fig. 15). Squeeze the element to distribute the oil.

IMPORTANT: Replace the foam element if it is torn or worn.

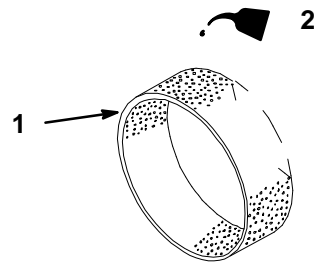

Figure 15

- | | |
|-----------------|--------|
| 1. Foam element | 2. Oil |
|-----------------|--------|

m-1213

m-2595

2. Paper Element

- A. Lightly tap the element on a flat surface to remove dust and dirt (Fig. 16).
- B. Inspect the element for tears, an oily film, and damage to the rubber seal.

IMPORTANT: Never clean the paper element with pressurized air or liquids, such as solvent, gas, or kerosene. Replace the paper element if it is damaged, defective, or cannot be cleaned thoroughly.

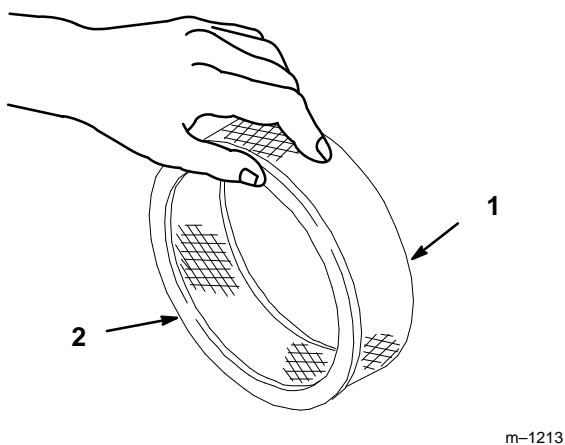

Figure 16

1. Paper element
2. Rubber seal

Engine Oil

Change oil:

- After the first 8 operating hours.
- After every 100 operating hours.

Note: Change oil more frequently when operating conditions are extremely dusty or sandy.

Oil Type: Detergent oil (API service SF, SG or SH)

Crankcase Capacity: w/filter, 2 qt. (1.9 l)

Viscosity: See table below

USE THESE SAE VISCOSITY OILS

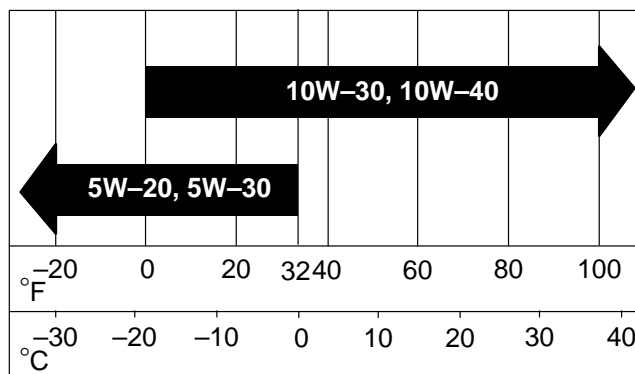

Installing the Foam and Paper Elements

1. Installing the Foam and Paper Elements

IMPORTANT: To prevent engine damage, always operate the engine with the complete foam and paper air cleaner assembly installed.

1. Carefully slide the foam element onto the paper air cleaner element (Fig. 14).
2. Place the air cleaner assembly onto the air cleaner base (Fig. 14).
3. Install the air cleaner cover and secure with cover nuts (Fig. 14).

Checking Oil Level

1. Park the machine on a level surface, disengage the power take off (PTO) and turn the ignition key to “OFF” to stop the engine. Remove the key.
2. Clean around the oil dipstick (Fig. 17) so dirt cannot fall into the filler hole and damage the engine.
3. Unscrew the oil dipstick and wipe the metal end clean (Fig. 17).
4. Slide the oil dipstick fully into the filler tube, do not thread onto tube (Fig. 17). Pull the dipstick out and look at the metal end. If oil level is low, slowly pour only enough oil into the filler tube to raise the level to the “FULL” mark.

IMPORTANT: Do not overfill the crankcase with oil because the engine may be damaged.

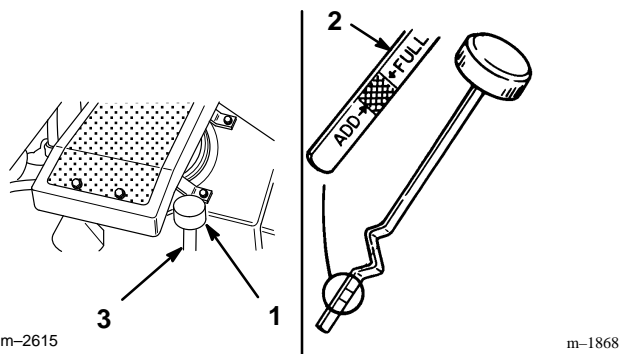

Figure 17

1. Oil dipstick
2. Metal end
3. Filler tube

Changing/Draining Oil

1. Start the engine and let it run five minutes. This warms the oil so it drains better.
2. Park the machine so that the drain side is slightly lower than the opposite side to assure the oil drains completely. Then disengage the power take off (PTO) and turn the ignition key to “OFF” to stop the engine. Remove the key.
3. Place a pan below the oil drain. Remove the oil drain cap (Fig. 18).
4. When oil has drained completely, install the oil drain cap.

Note: Dispose of the used oil at a certified recycling center.

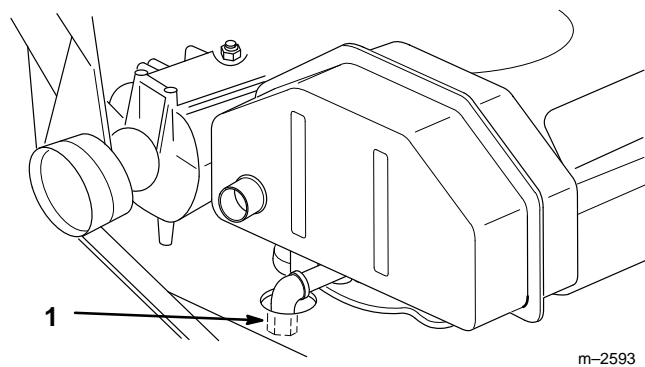

Figure 18

1. Oil drain cap

5. Slowly pour approximately 80% of the specified amount of oil specified, page 23, into the filler tube (Fig. 17). Now check the oil level; refer to Checking Oil Level, page 24. Slowly add additional oil to bring to “FULL” mark on dipstick.

Change Oil Filter

Replace the oil filter every 200 hours or every other oil change.

Note: Change oil filter more frequently when operating conditions are extremely dusty or sandy.

1. Drain the oil from the engine; refer to Changing/Draining Oil, page 24.
2. Remove the old filter and wipe the filter adapter (Fig. 19) gasket surface.
3. Apply a thin coat of new oil to the rubber gasket on the replacement filter (Fig. 19).

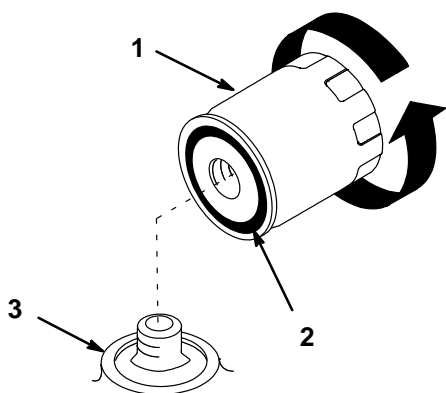

m-1256

Figure 19

- | | |
|---------------|------------|
| 1. Oil filter | 3. Adapter |
| 2. Gasket | |

4. Install the replacement oil filter to the filter adapter. Turn the oil filter clockwise until the rubber gasket contacts the filter adapter, then tighten the filter an additional 1/2 turn (Fig. 19).
5. Fill the crankcase with the proper type of new oil; refer to Changing/Draining Oil, page 24.

Spark Plug

Check the spark plug(s) after every 200 operating hours. Make sure the air gap between the center and side electrodes is correct before installing the spark plug. Use a spark plug wrench for removing and installing the spark plug(s) and a gapping tool/feeler gauge to check and adjust the air gap. Install a new spark plug(s) if necessary.

Type: Champion RC12YC (or equivalent) Air Gap: 0.040 in. (1.02 mm)

Removing the Spark Plug(s)

1. Disengage the power take off (PTO), set the parking brake, and turn the ignition key to "OFF" to stop the engine. Remove the key.
2. Pull the wire(s) off the spark plug(s) (Fig. 20). Now clean around the spark plug(s) to prevent dirt from falling into the engine and potentially causing damage.
3. Remove the spark plug(s) and metal washer.

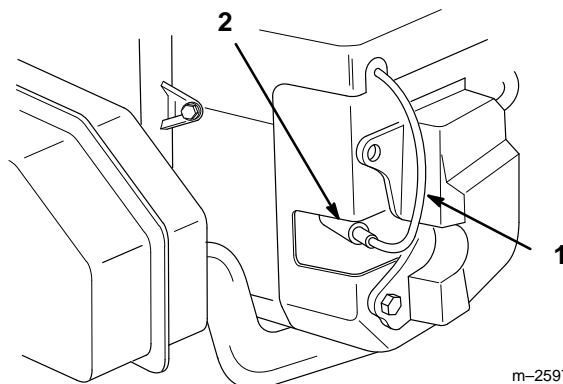

m-2597

Figure 20

- | | |
|--------------------|---------------|
| 1. Spark plug wire | 2. Spark plug |
|--------------------|---------------|

Checking the Spark Plug

1. Look at the center of the spark plug(s) (Fig. 21). If you see light brown or gray on the insulator, the engine is operating properly. A black coating on the insulator usually means the air cleaner is dirty.

IMPORTANT: Never clean the spark plug(s). Always replace the spark plug(s) when it has: a black coating, worn electrodes, an oily film, or cracks.

2. Check the gap between the center and side electrodes (Fig. 21). Bend the side electrode (Fig. 21) if the gap is not correct.

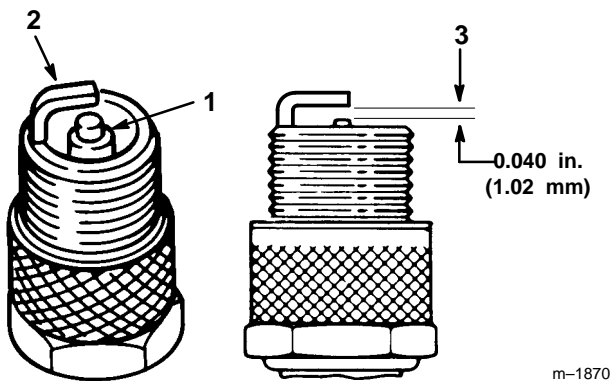

Figure 21

1. Center electrode insulator
2. Side electrode
3. Air gap (not to scale)

Installing the Spark Plug(s)

1. Install the spark plug(s) and metal washer. Make sure the air gap is set correctly.
2. Tighten the spark plug(s) to 20 ft-lb (27 N.m).
3. Push the wire(s) onto the spark plug(s) (Fig. 20).

Cleaning the Cooling Systems

Before each use, check and clean hydraulic and engine cooling systems. Remove any build-up of grass, dirt or other debris from the oil cooler screen and engine air intake. Every 100 hours clean oil cooler, engine cylinder and cylinder head cooling fins. Also clean around carburetor, governor levers and linkage. This will help insure adequate cooling to hydraulic pumps, motors and engine and will reduce the possibility of overheating and mechanical damage.

1. Remove oil cooler from the engine (Fig. 22). Save all mounting hardware.
2. Blow out fins of oil cooler and area between fins and screen with compressed air. If area between screen and fins is tightly packed, remove oil cooler from screen. Removing two retaining screws (Fig. 22). Save all mounting hardware.
3. Clean off engine air intake (Fig. 22).
4. Install oil cooler onto engine with previously removed hardware (Fig. 22).

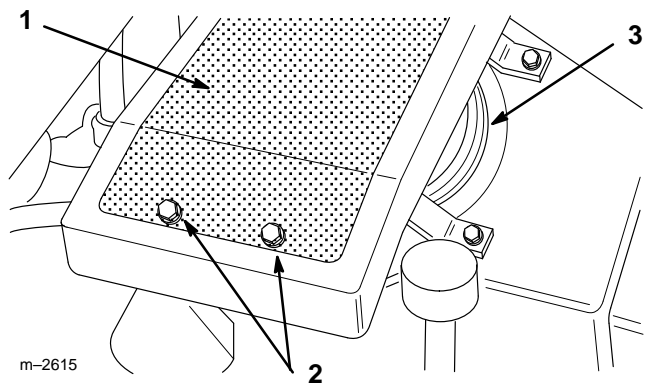

Figure 22

1. Oil cooler screen
2. Oil cooler retaining screw
3. Engine air intake

Tire Pressure

Maintain the air pressure in the front and rear tires as specified. Uneven tire pressure can cause uneven cut. Check the pressure at the valve stem after every 50 operating hours or monthly, whichever occurs first (Fig. 23). Check the tires when they are cold to get the most accurate pressure reading.

Pressure: 15 psi (.103 kPa) rear and castor tires

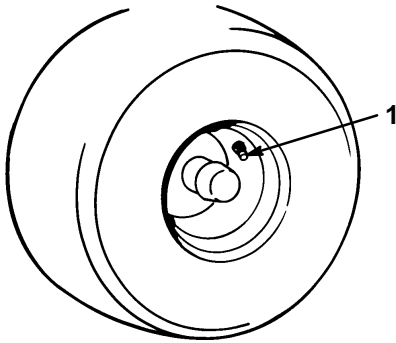

m-1872

Figure 23

1. Valve stem

Fuse

Service Interval/Specification

The electrical system is protected by a fuse. It requires no maintenance, however, if the fuse blows check component/circuit for malfunction or short. To replace fuse pull out on the fuse (Fig. 24) to remove or replace it.

Fuse: F1-7.5 amp, blade-type

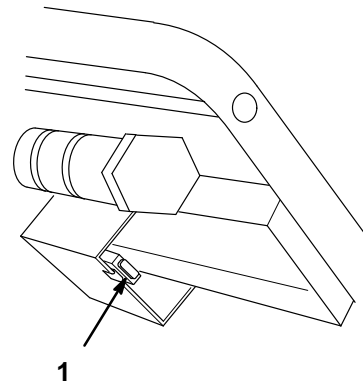

m-3100

Figure 24

1. Fuse 7.5 amp

Fuel Tank

DANGER

POTENTIAL HAZARD

- In certain conditions gasoline is extremely flammable and highly explosive.

WHAT CAN HAPPEN

- A fire or explosion from gasoline can burn you, others, and cause property damage.

HOW TO AVOID THE HAZARD

- Drain gasoline from the fuel tank when the engine is cold. Do this outdoors in an open area. Wipe up any gasoline that spills.
- Never drain gasoline near an open flame or where gasoline fumes may be ignited by a spark.
- Never smoke a cigarette, cigar or pipe.

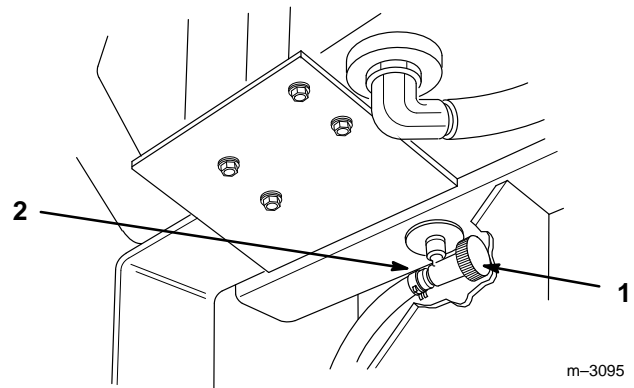

Figure 25

1. Fuel shut-off valve 2. Clamp

Draining The Fuel Tank

1. Park the machine on a level surface, to assure fuel tank drains completely. Then disengage the power take off (PTO) and turn the ignition key to "OFF" to stop the engine. Remove the key.
2. Close fuel shut-off valve at fuel tank (Fig. 25).
3. Squeeze the ends of the hose clamp together and slide it up the fuel line away from valve (Fig. 25).
4. Pull the fuel line off the valve (Fig. 25). Open fuel shut-off valve and allow gasoline to drain into a gas can or drain pan.

Note: Now is the best time to install a new fuel filter because the fuel tank is empty. Refer to Replacing the Fuel Filter; page 29.

5. Install the fuel line onto the valve. Slide the hose clamp close to the valve to secure the fuel line.

Fuel Filter

Replace the fuel filter after every 200 operating hours or yearly, whichever occurs first.

Replacing the Fuel Filter

Never install a dirty filter if it is removed from the fuel line.

1. Disengage the power take off (PTO) and turn the ignition key to "OFF" to stop the engine. Remove the key.
2. Close fuel shut-off valve at fuel tank (Fig. 25).
3. Squeeze the ends of the hose clamps together and slide them away from the filter (Fig. 26).
4. Remove the filter from the fuel lines.
5. Install a new filter and move the hose clamps close to the filter.
6. Open fuel shut-off valve at fuel tank (Fig. 25).

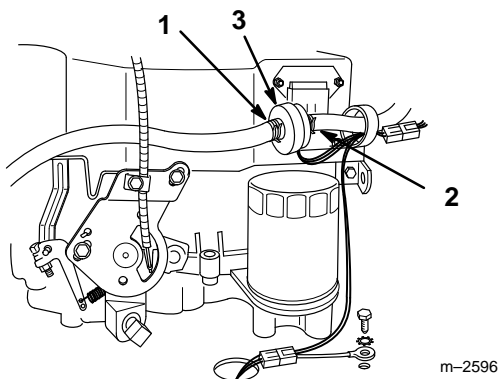

Figure 26

- | | |
|---------------|-----------|
| 1. Hose clamp | 3. Filter |
| 2. Fuel line | |

Hydraulic System

Checking the Hydraulic Fluid

Check the hydraulic fluid level before engine is first started and after every 8 operating hours.

Fluid Type: Mobilube 424 (ISO 68) or equivalent anti-wear hydraulic fluid.

IMPORTANT: Use only hydraulic oils specified. Other fluids could cause system damage.

Tank Capacity: 1-3/4 qt. (1.6 l)

1. Position machine on a level surface and stop the engine.
2. Clean area around filler neck and cap/dipstick of hydraulic tank (Fig. 27).
3. Remove cap/dipstick from filler neck and wipe with a clean rag. Insert cap/dipstick and seat cap all the way into filler neck; then remove and check fluid level. Fluid level should be in between marks on dipstick.
4. If level is low, add fluid to raise level to full mark.
5. Install cap/dipstick onto filler neck.

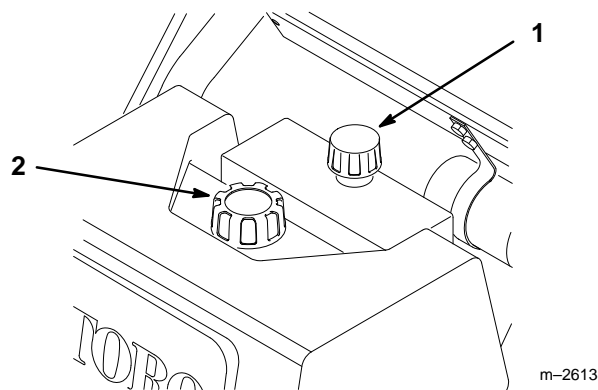

Figure 27

- | | |
|-----------------------|---------------------------|
| 1. Hydraulic tank cap | 2. Fuel tank cap/dipstick |
|-----------------------|---------------------------|

Replacing the Hydraulic Filter

Change the hydraulic filter:

- After the first 8 operating hours.
 - After every 200 operating hours.
1. Position machine on a level surface, stop the engine, and remove key from ignition switch.

IMPORTANT: Do not substitute automotive oil filter or severe hydraulic system damage may result.

2. Place drain pan under filter, remove the old filter and wipe the filter adapter gasket surface (Fig. 28).

Note: Make sure fluid is completely drained before installing new filter.

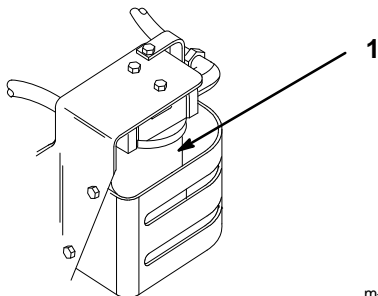
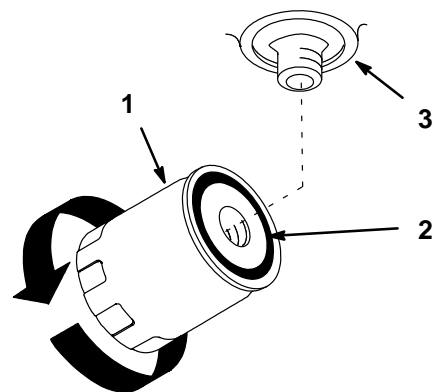

Figure 28

m-2623

1. Hydraulic filter
-

3. Apply a thin coat of new oil to the rubber gasket on the replacement filter (Fig. 29).
4. Install replacement hydraulic filter onto the filter adapter. Turn the oil filter clockwise until the rubber gasket contacts the filter adapter, then tighten the filter an additional 1/2 turn (Fig. 29).
5. Start engine and let run for about two minutes to purge air from the system. Stop the engine and check for leaks. If one or both wheels will not drive, refer Bleeding Hydraulic System, page 31.
6. Check fluid level in hydraulic tank and add to raise level to FULL mark on dipstick. **DO NOT OVER FILL.**



m-1256

Figure 29

1. Hydraulic filter
 2. Gasket
 3. Adapter
-

Bleeding Hydraulic System

The traction system is self bleeding, however, it may be necessary to bleed the system if fluid is changed or after work is performed on the system.

1. Raise the rear of machine until wheels are off the floor and support with jack stands.
2. Start the engine and run at idle speed. Engage traction on one side and spin the wheel by hand.
3. When the wheel begins to spin on its own, keep it engaged until wheel drives smoothly. (minimum 2 minute)
4. Check hydraulic fluid level as it drops and add as required to maintain level.
5. Repeat procedure on opposite wheel.

Check Hydraulic Lines

After every 100 operating hours, check hydraulic lines and hoses for leaks, loose fittings, kinked lines, loose mounting supports, wear, weather and chemical deterioration. Make necessary repairs before operating.

WARNING

POTENTIAL HAZARD

- Hydraulic fluid escaping under pressure can penetrate skin and cause injury.

WHAT CAN HAPPEN

- Fluid accidentally injected into the skin must be surgically removed within a few hours by a doctor familiar with this form of injury or gangrene may result.

HOW TO AVOID THE HAZARD

- Keep body and hands away from pin hole leaks or nozzles that eject high pressure hydraulic fluid.
- Use cardboard or paper to find hydraulic leaks.

Adjusting By-pass Valve

The by-pass valve is adjustable to ensure easy operation with a variety of deck sizes. If the front of the deck lifts off the ground when the upper control bar is quickly pushed forward or the machine is unable to drive up hills, an adjustment may be needed.

Test Procedure

1. Start engine and run for 5 minutes at 3/4 throttle, to warm hydraulic fluid.
2. Drive the machine to a clear and level open area such as a driveway.

IMPORTANT: There should be at least 10 feet of clear area in front of the machine.

3. Loosen the quick release levers and push the reference bar forward to the “FAST” position. Lock the quick release levers to secure the reference bar.
4. Move throttle control to 3/4 throttle.
5. Quickly push the upper control bar against the reference bar. The front caster wheels should almost lift off the ground. If front caster wheels lift the off the ground , the machine is too aggressive and adjustment is required.
6. Move the engine throttle to the “FAST” position.
7. Quickly push the upper control bar against the reference bar. The front caster wheels should lift 1 to 3 inches off the ground. If front caster wheels lift the off the ground more than 3 inches, the machine is too aggressive. Adjustment is required.
8. If the machine accelerates slowly, and the front caster wheels do not lift off the ground, the machine is too un-responsive. Adjustment is required.

Adjustment Procedure

The by-pass valve should be adjusted to deliver best performance for the size (weight) mower you have. The by-pass valve factory setting is 1/2 turn out.

The following values can be used as initial settings for different size mowers:

- 62" 1/6 turn out
- 52" 1/2 turn out
- 44" 1 turn out
- 36" 1 turn out

9. Loosen large jam nut several turns (Fig. 30).
10. Gently close by-pass valve (Fig. 30).

IMPORTANT: Do not over-tighten valve or needle and seat may be damaged. Do not exceed 50 inch pounds to close valve.

11. Open by-pass valve 1/2 turn (Fig. 30).
12. Tighten jam nut to lock the adjustment (Fig. 30).
13. Repeat "Test Procedure" to check for proper operation.

IMPORTANT: By-pass valve adjustment is very sensitive, do not adjust more than 1/6 turn (one flat) at a time.

14. If the machine is too aggressive, the valve needs to be open further.
15. If the machine is un-responsive, the valve needs to be closed further.
16. Repeat "Test Procedure" to check for proper operation. Re-adjust the by-pass valves until proper performance is achieved.

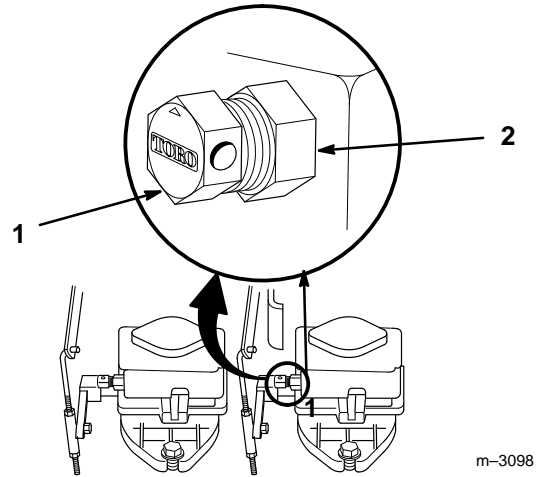

Figure 30

1. By-pass valve 2. Jam nut
-

Replacing the Traction Belt

Check traction drive belt for wear after every 50 hours of operation.

1. Raise the front of the machine and hold with jack stands.
2. Disconnect in-line wire connector from wire harness to electric clutch.
3. Remove mower drive belt; refer to mower Operator's Manual.
4. Remove left front engine mounting bolt securing clutch retainer to frame (Fig. 31). Unhook retainer from clutch and remove retainer.
5. Move idler pulley and remove traction belt from the drive pulleys and clutch.
6. Install new belt around clutch and drive pulleys.
7. Hook clutch retainer into clutch and secure to frame with engine mounting bolt. Torque engine mounting bolt to 170-220 in. lb. (19-24 N.m).
8. Connect clutch in-line wire connector to wire harness.

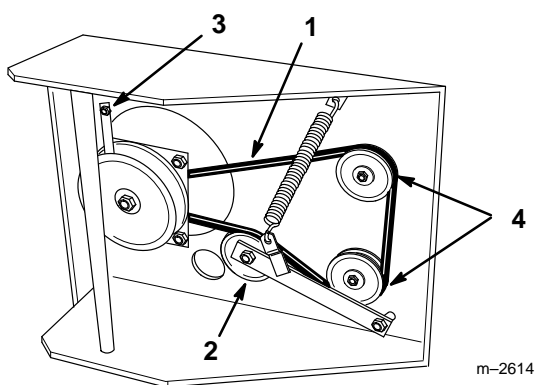

Figure 31

- | | |
|------------------|--------------------|
| 1. Traction belt | 3. Clutch retainer |
| 2. Idler pulley | 4. Drive pulley |

Adjusting the Electric Clutch

The clutch is adjustable to ensure proper engagement and proper braking. Check adjustment after every 100 hours of operation.

1. To adjust clutch, tighten or loosen lock nuts on flange studs (Fig. 32).
2. Check adjustment by inserting feeler gauge through slots next to studs (Fig. 32).
3. The proper disengaged clearance between the clutch plates is .012-.018 in. (0.30-0.45 mm). It will be necessary to check this clearance at each of the three slots to ensure the plates are parallel to each other.

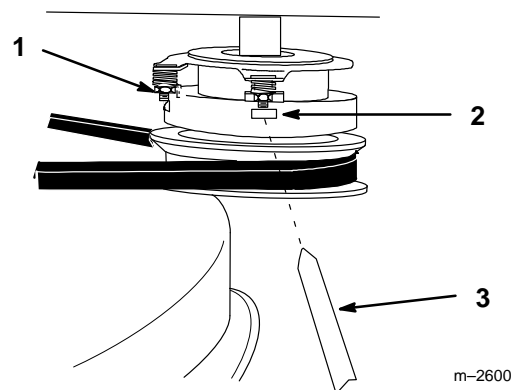

Figure 32

- | | |
|------------------|-----------------|
| 1. Adjusting nut | 3. Feeler gauge |
| 2. Slot | |

Adjusting Neutral

If wheels turn when control bar is in neutral, adjustment is required

1. Raise rear of the machine so wheels are off the ground and support with jack stands.

CAUTION

POTENTIAL HAZARD

- Someone could move or attempt to operate the machine while it is unattended.

WHAT CAN HAPPEN

- Children or bystanders may be injured if they use the machine.

HOW TO AVOID THE HAZARD

- Always remove the ignition key when leaving the machine unattended, even if just for a few minutes.

2. Start engine and run for 5 minutes at 3/4 throttle, to warm hydraulic fluid.
3. Move control bar rearward and forward then release. If wheels rotate when control bar is in neutral, adjustment is required.
4. Loosen top and bottom jam nuts at pump arm neutral adjustment sleeve (Fig. 33).
5. Push down on Pump Arm until Sleeve contacts bottom nut (Fig. 33). Wheel should now be rotating slowly in reverse.
6. Turn bottom nut up slowly, moving sleeve and pump arm up, until wheel stops rotating (Fig. 33).
7. Turn top nut down against sleeve and tighten to lock the adjustment (Fig. 33).
8. Repeat step 3 above to check adjustment. Repeat adjustment procedure if necessary.
9. Repeat on other wheel, if necessary.

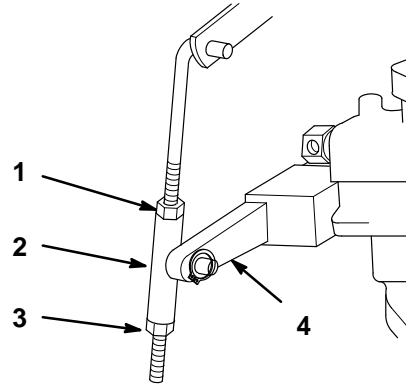

m-3071

Figure 33

1. Top jam nut
2. Sleeve
3. Bottom jam nut
4. Pump arm

Battery

Check the electrolyte level in the battery before each use. Always keep the battery clean and fully charged. Use a paper towel to clean the battery case. If the battery terminals are corroded, clean them with a solution of four parts water and one part baking soda. Apply a light coating of grease to the battery terminals to prevent corrosion.

Voltage: 12 v, 280 Cold Cranking Amps

Checking Electrolyte Level

1. Open covers to see into the cells. The electrolyte must be up to the lower part of the tube (Fig. 34). Do not allow the electrolyte to get below the plates. (Fig. 34).
2. If the electrolyte is low, add the required amount of distilled water; refer to Adding Water to the Battery, page 35.

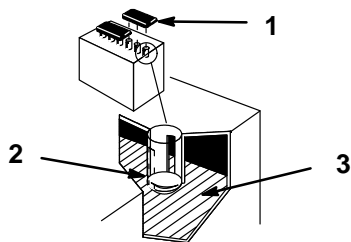

Figure 34

m-1262

1. Filler caps
2. Lower part of tube
3. Plates

Adding Water to the Battery

The best time to add distilled water to the battery is just before you operate the machine. This lets the water mix thoroughly with the electrolyte solution.

1. Clean the top of the battery with a paper towel.
2. Lift off the filler caps (Fig. 34).
3. Slowly pour distilled water into each battery cell until the level is up to the lower part of the tube (Fig. 34).

IMPORTANT: Do not overfill the battery because electrolyte (sulfuric acid) can cause severe corrosion and damage to the chassis.

4. Press the filler caps onto the battery.

Charging the Battery

IMPORTANT: Always keep the battery fully charged (1.260 specific gravity). This is especially important to prevent battery damage when the temperature is below 32°F (0°C).

1. Check the electrolyte level; refer to Checking Electrolyte Level, page 35.
2. Remove the filler caps from the battery and connect a 3 to 4 amp battery charger to the battery posts. Charge the battery at a rate of 4 amperes or less for 4 hours (12 volts). Do not overcharge the battery. Install the filler caps after the battery is fully charged.

! WARNING

POTENTIAL HAZARD

- Charging the battery produces gasses.

WHAT CAN HAPPEN

- Battery gasses can explode.

HOW TO AVOID THE HAZARD

- Keep cigarettes, sparks and flames away from battery.

Wiring Diagram

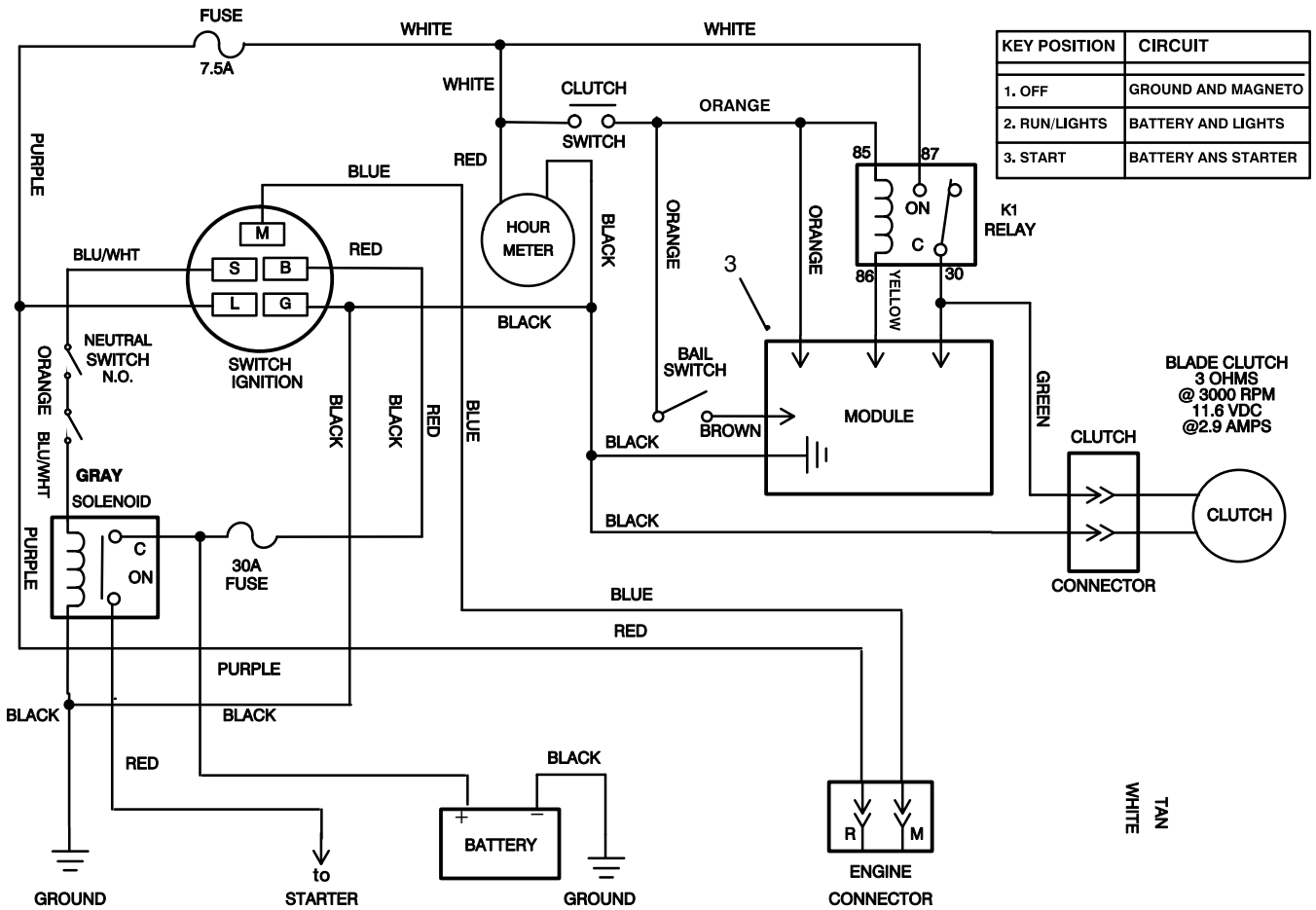

Hydraulic Diagram

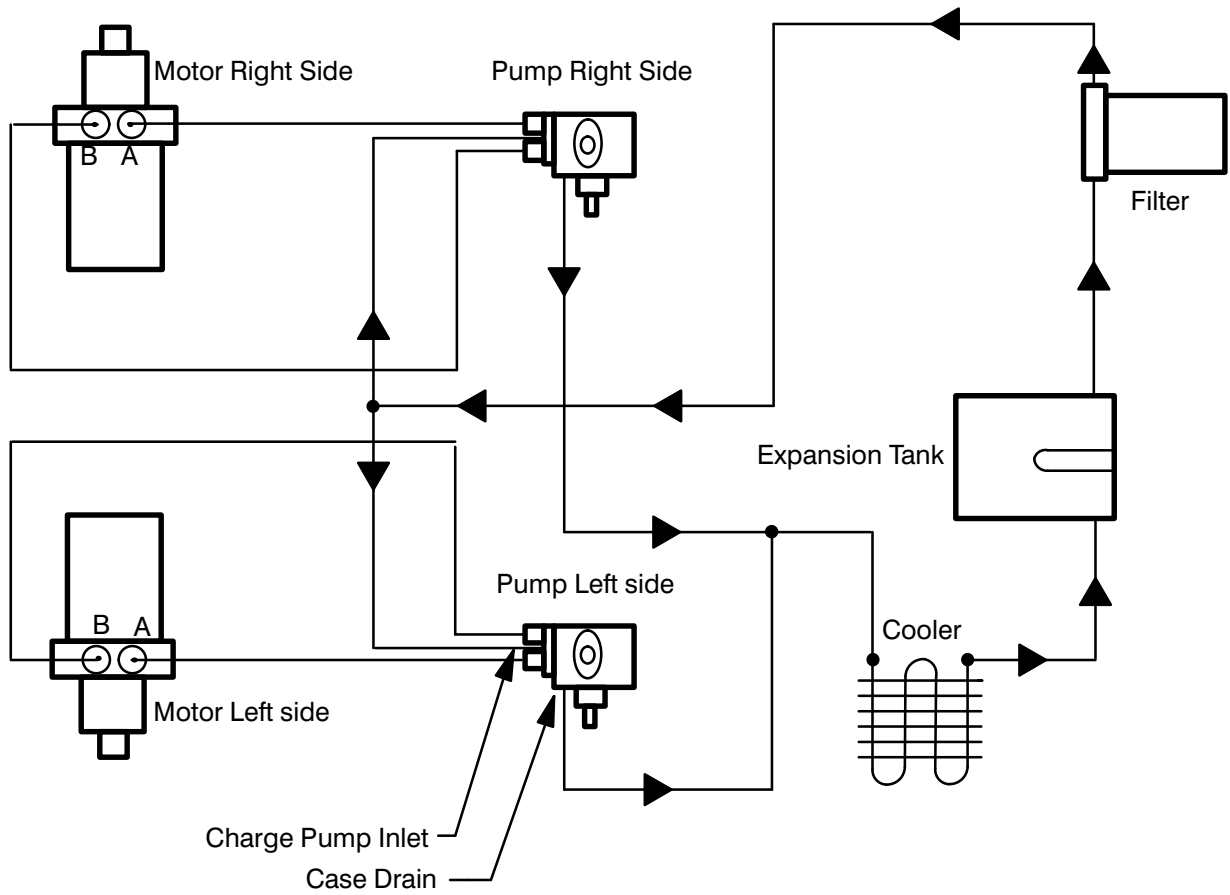

Cleaning and Storage

1. Disengage the power take off (PTO) and turn the ignition key to “OFF” to stop the engine. Remove the key.
2. Remove grass clippings, dirt, and grime from the external parts of the entire machine, especially the engine. Clean dirt and chaff from the outside of the engine’s cylinder head fins and blower housing.

IMPORTANT: You can wash the machine with mild detergent and water. Do not pressure wash the machine. Avoid excessive use of water, especially near the control panel, engine, hydraulic pumps and motors.

3. Service the air cleaner; refer to Air Cleaner, page 22.
4. Change the crankcase oil; refer to Engine Oil, page 23.
5. Change the hydraulic fluid; refer to Hydraulic System, page 29.
6. Remove the spark plug(s) and check its condition; refer to Spark Plug, page 25. With the spark plug(s) removed from the engine, pour two tablespoons of engine oil into the spark plug hole. Now use the starter to crank the engine and distribute the oil inside the cylinder. Install the spark plug(s). Do not install the wire on the spark plug(s).
7. Check the tire pressure; refer to Tire Pressure, page 27.

8. For long-term storage (more than 90 days) add stabilizer/conditioner additive to fuel in the tank (1 oz. per gallon).
 - A. Run engine to distribute conditioned fuel through the fuel system (5 minutes).
 - B. Stop engine, allow to cool and drain the fuel tank; refer to Fuel Tank, page 28, or operate engine until it stops.
 - C. Restart engine and run until it stops. Repeat, on “CHOKE” until engine will not restart.
 - D. Dispose of fuel properly. Recycle as per local codes.

Note: Do not store stabilizer/conditioned gasoline over 90 days.

9. Check and tighten all bolts, nuts, and screws. Repair or replace any part that is damaged or defective.
10. Paint all scratched or bare metal surfaces. Paint is available from your Authorized Service Dealer.
11. Store the machine in a clean, dry garage or storage area. Remove the key from the ignition switch and keep it in a memorable place. Cover the machine to protect it and keep it clean.

Troubleshooting

PROBLEM	POSSIBLE CAUSES	CORRECTIVE ACTION
Engine will not start, starts hard, or fails to keep running.	<ol style="list-style-type: none"> 1. Fuel tank is empty. 2. Choke is not ON. 3. Air cleaner is dirty. 4. Spark plug wire is loose or disconnected. 5. Spark plug is pitted, fouled, or gap is incorrect. 6. Dirt in fuel filter. 7. Dirt, water, or stale fuel is in fuel system. 8. Battery is dead. 	<ol style="list-style-type: none"> 1. Fill fuel tank with gasoline. 2. Move choke lever to ON. 3. Clean or replace air cleaner element. 4. Install wire on spark plug. 5. Install new, correctly gapped spark plug. 6. Replace fuel filter. 7. Contact Authorized Service Dealer. 8. Charge battery.
Engine loses power.	<ol style="list-style-type: none"> 1. Engine load is excessive. 2. Air cleaner is dirty. 3. Oil level in crankcase is low. 4. Cooling fins and air passages under engine blower housing are plugged. 5. Spark plug is pitted, fouled, or gap is incorrect. 6. Vent hole in fuel cap is plugged. 7. Dirt in fuel filter. 8. Dirt, water, or stale fuel is in fuel system. 	<ol style="list-style-type: none"> 1. Reduce ground speed. 2. Clean air cleaner element. 3. Add oil to crankcase. 4. Remove obstruction from cooling fins and air passages. 5. Install new, correctly gapped spark plug. 6. Clean or replace the fuel cap. 7. Replace fuel filter. 8. Contact Authorized Service Dealer.
Engine overheats.	<ol style="list-style-type: none"> 1. Engine load is excessive. 2. Oil level in crankcase is low. 3. Cooling fins and air passages under engine blower housing are plugged. 	<ol style="list-style-type: none"> 1. Reduce ground speed. 2. Add oil to crankcase. 3. Remove obstruction from cooling fins and air passages.
Abnormal vibration.	<ol style="list-style-type: none"> 1. Engine mounting bolts are loose. 2. Loose engine pulley, idler pulley, or blade pulley. 3. Engine pulley is damaged. 	<ol style="list-style-type: none"> 1. Tighten engine mounting bolts. 2. Tighten the appropriate pulley. 3. Contact Authorized Service Dealer.

PROBLEM	POSSIBLE CAUSES	CORRECTIVE ACTION
Machine does not drive.	<ol style="list-style-type: none"> 1. Hydrostatic fluid level low. 2. Traction belt is worn, loose or broken. 3. Traction belt is off pulley. 	<ol style="list-style-type: none"> 1. Fill hydrostatic fluid tank. 2. Change Belt. 3. Change Belt.
Machine does not drive up hills or inclines.	<ol style="list-style-type: none"> 1. By-pass valve is adjusted too far open. 	<ol style="list-style-type: none"> 1. Adjust by-pass valve
Machine moves slowly in neutral.	<ol style="list-style-type: none"> 1. Neutral is mis-adjusted. 2. Return spring is broken or missing. 3. Linkage is dirty or bent. 	<ol style="list-style-type: none"> 1. Adjust hydro pump neutral. 2. Replace return spring. 3. Clean and lubricate linkage. Replace bent or worn parts.
Machine drive is too aggressive. Mower lifts when drive is engaged.	<ol style="list-style-type: none"> 1. By-pass valve is adjusted too far closed. 	<ol style="list-style-type: none"> 1. Adjust by-pass valve



THE TORO TOTAL COVERAGE GUARANTEE

A One-Year Limited Warranty
(A Two-Year Full Warranty for Residential Use)

What Is Covered By This Express Warranty?

The Toro Company promises to repair any TORO product used for commercial, institutional, or rental purposes if defective in materials or workmanship for a period of one year from the date of purchase. The cost of parts and labor are included, but the customer pays the transportation cost. Transportation within a 15-mile radius of a TORO ProLine Service Dealer is covered under this warranty for Riding Products, Mid-size Mowers and Turf Maintenance Equipment.

What Products Are Covered By This Warranty?

The following products and their attachments are covered by this warranty:

- Z-Master Zero Radius Tractors
- ProLine Mid-size Mowers
- Groundsmaster Riding Mowers
- ProLine Hand-held Gas Products
- Backpack Blowers
- Commercial WPM
- Turf Maintenance Equipment
- Debris Management Equipment

How About Residential Use?

TORO products used for residential use are covered by a full two-year warranty.

How Do You Get Warranty Service?

Should you feel your TORO product contains a defect in materials or workmanship, contact the dealer who sold you the product or any TORO ProLine Service Dealer. The Yellow Pages of your telephone directory is a good reference source; look under TORO Commercial Service Dealers. The Service Dealer will either arrange service at his/her dealership or recommend another authorized Service Dealer who may be more convenient. You may need proof of purchase (copy of registration card, sales receipt, etc.) for warranty validation.

If for any reason you are dissatisfied with a Service Dealer's analysis of the defect in materials or workmanship or if you need a referral to a TORO ProLine Service Dealer, please feel free to contact us at the following address:

Toro Customer Service Department
8111 Lyndale Avenue South
Bloomington, MN 55420-1196
612-888-8801 or 800-348-2424

What Must You Do To Keep The Warranty In Effect?

You must maintain your TORO Product by following the maintenance procedures described in the operator's manual. Such routine maintenance, whether performed by a dealer or by you, is at your expense.

What Does This Warranty Not Cover? and

How Does Your State Law Relate To This Warranty?

There is no other express warranty except as described above. This express warranty does not cover:

- Cost of regular maintenance service or parts, such as filters, fuel, lubricants, tune-up parts, blade sharpening, brake and clutch adjustments.
- Any product or part which has been altered or misused or required replacement or repair due to normal wear, accidents, or lack of proper maintenance.
- Repairs necessary due to improper fuel, contaminants in the fuel system, or failure to properly prepare the fuel system prior to any period of non-use over three months.
- Pickup and delivery charges for distances beyond a 15-mile radius from a TORO ProLine Service Dealer.

All repairs covered by this warranty must be performed by a TORO Service Dealer using Toro approved replacement parts.

The Toro Company is not liable for indirect or consequential damages in connection with the use of the TORO Products covered by this warranty, including any cost or expense of providing substitute equipment or service during reasonable periods of malfunction or non-use pending completion of repairs under this warranty. Some states do not allow exclusions of incidental or consequential damages, so the above exclusion may not apply to you.

This warranty gives you specific legal rights, and you may also have other rights which vary from state to state.

COUNTRIES OTHER THAN THE UNITED STATES OR CANADA

Customers who have purchased TORO products exported from the United States or Canada should contact their TORO Distributor (Dealer) to obtain guarantee policies for your country, province, or state. If for any reason you are dissatisfied with your Distributor's service or have difficulty obtaining guarantee information, contact the TORO importer. If all other remedies fail, you may contact us at The Toro Company.