



Count on it.

Operator's Manual

**Z Master® Professional 5000 and
6000 Series Riding Mower
with 52in, 60in, or 72in TURBO FORCE® Side
Discharge Mower**

Model No. 74906—Serial No. 315000001 and Up

Model No. 74918—Serial No. 315000001 and Up

Model No. 74926—Serial No. 315000001 and Up

Model No. 74928—Serial No. 315000001 and Up

Model No. 74930—Serial No. 315000001 and Up

Model No. 78926—Serial No. 315000001 and Up

Model No. 78928—Serial No. 315000001 and Up



▲ WARNING

CALIFORNIA Proposition 65 Warning

This product contains a chemical or chemicals known to the State of California to cause cancer, birth defects, or reproductive harm.

The engine exhaust from this product contains chemicals known to the State of California to cause cancer, birth defects, or other reproductive harm.

This spark ignition system complies with Canadian ICES-002.

Because in some areas there are local, state, or federal regulations requiring that a spark arrester be used on the engine of this machine, a spark arrester is available as an option. If you require a spark arrester, contact your Authorized Toro Service Dealer.

Genuine Toro spark arresters are approved by the USDA Forestry Service.

Important: It is a violation of California Public Resource Code Section 4442 to use or operate the engine on any forest-covered, brush-covered, or grass-covered land without a spark arrester muffler maintained in working order, or the engine constricted, equipped, and maintained for the prevention of fire. Other states or federal areas may have similar laws.

The enclosed *Engine Owner's Manual* is supplied for information regarding the US Environmental Protection Agency (EPA) and the California Emission Control Regulation of emission systems, maintenance, and warranty. Replacements may be ordered through the engine manufacturer.

Introduction

This rotary-blade, riding lawn mower is intended to be used by residential homeowners or professional, hired operators. It is designed primarily for cutting grass on well-maintained lawns on residential or commercial properties. It is not designed for cutting brush or for agricultural uses.

Read this information carefully to learn how to operate and maintain your product properly and to avoid injury and product damage. You are responsible for operating the product properly and safely.

You may contact Toro directly at www.Toro.com for product safety and operation training materials, accessory information, help finding a dealer, or to register your product.

Whenever you need service, genuine Toro parts, or additional information, contact an Authorized Service Dealer or Toro

Customer Service and have the model and serial numbers of your product ready. Figure 1 identifies the location of the model and serial numbers on the product. Write the numbers in the space provided.

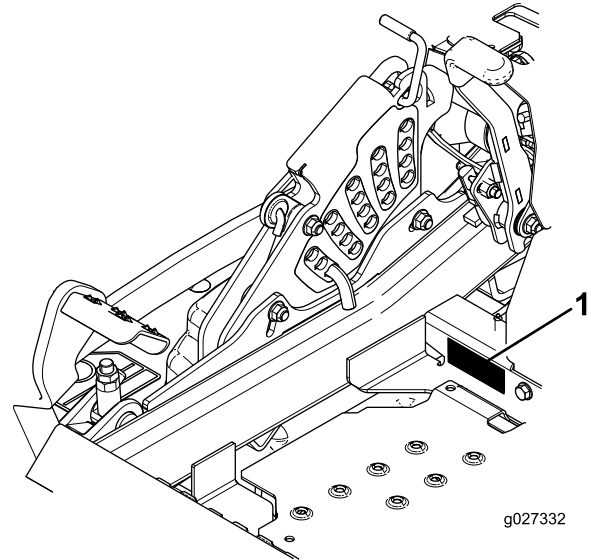

Figure 1

1. Model and serial number location

Model No. _____

Serial No. _____

This manual identifies potential hazards and has safety messages identified by the safety alert symbol (Figure 2), which signals a hazard that may cause serious injury or death if you do not follow the recommended precautions.



Figure 2

1. Safety alert symbol

This manual uses 2 words to highlight information.

Important calls attention to special mechanical information and **Note** emphasizes general information worthy of special attention.

Contents

Safety	4	Drive System Maintenance	44
Safe Operating Practices	4	Checking the Seat Belt.....	44
Slope Indicator	6	Checking the Knobs on the Rollover Protection	
Safety and Instructional Decals	7	System (ROPS)	44
Product Overview	13	Adjusting the Tracking	45
Controls	13	Checking the Tire Pressure	45
Specifications	14	Checking the Wheel Lug Nuts	46
Operation	15	Checking the Wheel Hub Slotted Nut.....	46
Adding Fuel.....	15	Adjusting the Caster Pivot Bearing.....	46
Checking the Engine-Oil Level.....	16	Using the Clutch Shim	46
Breaking in a New Machine.....	16	Cooling System Maintenance	48
Using the Rollover Protection System (ROPS)	16	Cleaning the Engine Screen and Engine-Oil	
Think Safety First.....	17	Cooler.....	48
Operating the Parking Brake	18	Cleaning the Engine Cooling Fins and	
Operating the Mower Blade-Control Switch		Shrouds.....	48
(PTO)	18	Check and Clean the Hydraulic-Unit Shrouds	49
Operating the Throttle.....	19	Brake Maintenance	50
Operating the Ignition Switch	19	Adjusting the Parking Brake.....	50
Using the Fuel-Shutoff Valve	19	Belt Maintenance	51
Starting and Stopping the Engine.....	19	Inspecting the Belts	51
The Safety-Interlock System	20	Replacing the Mower Belt.....	51
Driving Forward or Backward	21	Replacing the Hydraulic Pump Drive Belt.....	52
Stopping the Machine	22	Controls System Maintenance	53
Adjusting the Height of Cut	22	Adjusting the Control Handle Position	53
Adjusting the Anti-Scalp Rollers	23	Adjusting the Motion-Control Linkage.....	53
Adjusting the Flow Baffle Cam Locks.....	24	Adjusting the Motion-Control Damper	54
Positioning the Flow Baffle.....	24	Adjusting the Motion-Control Neutral Lock	
Positioning the Seat	25	Pivot.....	54
Unlatching the Seat.....	25	Hydraulic System Maintenance	55
Changing the Seat Suspension	26	Servicing the Hydraulic System.....	55
Using the Drive Wheel Release Valves	26	Mower Deck Maintenance.....	57
Using the Side Discharge.....	26	Leveling the Mower Deck.....	57
Transporting the Machine.....	27	Servicing the Cutting Blades.....	60
Loading the Machine	27	Removing the Mower Deck	62
Operating Tips	29	Replacing the Grass Deflector.....	64
Maintenance	30	Cleaning	64
Recommended Maintenance Schedule(s)	30	Cleaning under the Mower	64
Lubrication	31	Disposing of Waste.....	64
Lubricating the Machine.....	31	Storage	65
Greasing the Mower	31	Cleaning and Storage	65
Lubricate the Caster Wheel Hubs.....	33	Troubleshooting	66
Engine Maintenance	34	Schematics	69
Servicing the Air Cleaner.....	34		
Servicing the Engine Oil.....	35		
Servicing the Spark Plugs.....	38		
Check Spark Arrestor (if equipped).....	40		
Fuel System Maintenance	40		
Servicing the Electronic Fuel Injection			
System	40		
Replacing the Low-Pressure Fuel Filter.....	40		
Servicing the High-Pressure Fuel Filter.....	41		
Servicing the Fuel Tank.....	41		
Electrical System Maintenance	41		
Servicing the Battery.....	41		
Servicing the Fuses.....	43		
Jump-Starting the Machine	43		

Safety

Improperly using or maintaining the machine can result in injury. To reduce the potential for injury, comply with these safety instructions and always pay attention to the safety alert symbol, which means *Caution*, *Warning*, or *Danger*—personal safety instruction. Failure to comply with the instruction may result in personal injury or death.

This product is capable of amputating hands and feet and throwing objects. Always follow all safety instructions to avoid serious injury or death.

This product is designed for cutting and recycling grass or, when equipped with a grass bagger, for catching cut grass. Any use for purposes other than these could prove dangerous to the user and bystanders.

Safe Operating Practices

The following instructions are adapted from ANSI B71.4-2012.

Training

- Read the *Operator's Manual* and other training material. If the operator(s) or mechanic(s) cannot read or understand the information it is the owner's responsibility to explain this material to them.
- Become familiar with the safe operation of the equipment, operator controls, and safety signs.
- All operators and mechanics should be trained. The owner is responsible for training the users.
- Never let children or untrained people operate or service the equipment. Local regulations may restrict the age of the operator.
- The owner/user can prevent and is responsible for accidents or injuries occurring to people or damage to property.

Preparation

- Evaluate the terrain to determine what accessories and attachments are needed to properly and safely perform the job. Only use accessories and attachments approved by the manufacturer.
- Wear appropriate clothing including hard hat, safety glasses, and hearing protection. Long hair, loose clothing, or jewelry may get tangled in moving parts.
- Inspect the area where the equipment is to be used and remove all objects such as rocks, toys, and wire which can be thrown by the machine.
- Check that operator's presence controls, safety switches, and shields are attached and functioning properly. Do not operate unless they are functioning properly.

Operation

- Lightning can cause severe injury or death. If lightning is seen or thunder is heard in the area, do not operate the machine; seek shelter.
- Never run an engine in an enclosed area.
- Only operate in good light, keeping away from holes and hidden hazards.
- Be sure all drives are in neutral and parking brake is engaged before starting the engine. Only start the engine from the operator's position.
- Be sure of your footing while using this machine, especially when backing up. Walk; do not run. Never operate on wet grass. Reduced footing could cause slipping.
- Slow down and use extra care on hillsides. Be sure to travel side to side on hillsides. Turf conditions can affect the stability of the machine. Use caution while operating near drop-offs.
- Slow down and use caution when making turns and when changing directions on slopes.
- Never raise deck with the blades running.
- Never operate with the PTO shield or other guards not securely in place. Be sure all interlocks are attached, adjusted properly, and functioning properly.
- Never operate with the discharge deflector raised, removed or altered, unless using a grass catcher.
- Do not change the engine governor setting or overspeed the engine.
- Stop on level ground, disengage drives, engage the parking brake (if provided), and shut off the engine before leaving the operator's position for any reason, including emptying the catchers or unclogging the chute.
- Stop equipment and inspect blades after striking objects or if an abnormal vibration occurs. Make necessary repairs before resuming operations.
- Keep hands and feet away from the cutting unit.
- Look behind and down before backing up to be sure of a clear path.
- Never carry passengers on the machine.
- Keep pets and bystanders away.
- Slow down and use caution when making turns and crossing roads and sidewalks. Stop blades if not mowing.
- Be aware of the mower discharge direction and do not point it at anyone.
- Do not operate the mower under the influence of alcohol or drugs.
- Use care when loading or unloading the machine into or from a trailer or truck.
- Use care when approaching blind corners, shrubs, trees, or other objects that may obscure vision.

Rollover Protection System (ROPS)—Use and Maintenance

- The ROPS is an integral and effective safety device. Keep a folding ROPS in the raised and locked position and use the seat belt when operating the machine.
- Lower a folding ROPS temporarily only when absolutely necessary. Do not wear the seat belt when folded down.
- Be aware there is no rollover protection when a folded ROPS is in the down position.
- Be certain that the seat belt can be released quickly in the event of an emergency.
- Check the area to be mowed and never fold down a folding ROPS in areas where there are slopes, drop offs or water.
- Check carefully for overhead clearances (i.e. branches, doorways, electrical wires) before driving under any objects and do not contact them.
- Keep the ROPS in safe operating condition by periodically thoroughly inspecting for damage and keeping all mounting fasteners tight.
- Replace a damaged ROPS. Do not repair or revise.
- **Do not** remove the ROPS.
- Any alterations to a ROPS must be approved by the manufacturer.

Safe Handling of Fuels

- To avoid personal injury or property damage, use extreme care in handling gasoline. Gasoline is extremely flammable and the vapors are explosive.
- Extinguish all cigarettes, cigars, pipes, and other sources of ignition.
- Use only an approved fuel container.
- Never remove fuel cap or add fuel with the engine running.
- Allow engine to cool before refueling.
- Never refuel the machine indoors.
- Never store the machine or fuel container where there is an open flame, spark, or pilot light such as on a water heater or on other appliances.
- Never fill containers inside a vehicle or on a truck or trailer bed with a plastic liner. Always place containers on the ground away from your vehicle before filling.
- Remove equipment from the truck or trailer and refuel it on the ground. If this is not possible, then refuel such equipment with a portable container, rather than from a fuel dispenser nozzle.
- Keep the nozzle in contact with the rim of the fuel tank or container opening at all times until fueling is complete.
- Do not use a nozzle lock open device.

- If fuel is spilled on clothing, change clothing immediately.
- Never overfill fuel tank. Replace fuel cap and tighten securely.

Maintenance and Storage

- Disengage drives, set the parking brake, stop the engine and remove the key or disconnect the spark-plug wire. Wait for all movement to stop before adjusting, cleaning or repairing the machine.
 - Clean grass and debris from the cutting unit, the drives, the mufflers, and the engine to help prevent fires. Clean up oil or fuel spillage.
 - Let the engine cool before storing and do not store near flame.
 - Shut off the fuel while storing or transporting. Do not store fuel near flames or drain indoors.
 - Park the machine on level ground. Set the parking brake. Never allow untrained personnel to service the machine.
 - Use jack stands to support components when required.
 - Carefully release pressure from components with stored energy.
 - Disconnect the battery or the spark-plug wire before making any repairs. Disconnect the negative terminal first and the positive last. Connect the positive first and negative last.
 - Use care when checking the blades. Wrap the blade(s) or wear thickly-padded gloves, and use caution when servicing them. Only replace blades. Never straighten or weld them.
 - Keep hands and feet away from moving parts. If possible, do not make adjustments with the engine running.
 - Keep all parts in good working condition and all hardware tightened. Replace all worn or damaged decals.
 - To best protect your investment and maintain optimal performance of your Toro equipment, count on Toro genuine parts. When it comes to reliability, Toro delivers replacement parts designed to the exact engineering specifications of our equipment. For peace of mind, insist on Toro genuine parts.
- ## Hauling
- Use care when loading or unloading the machine into a trailer or truck.
 - Use full width ramps for loading the machine into a trailer or truck.
 - Tie the machine down securely using straps, chains, cable, or ropes. Both front and rear straps should be directed down and outward from the machine.

Slope Indicator

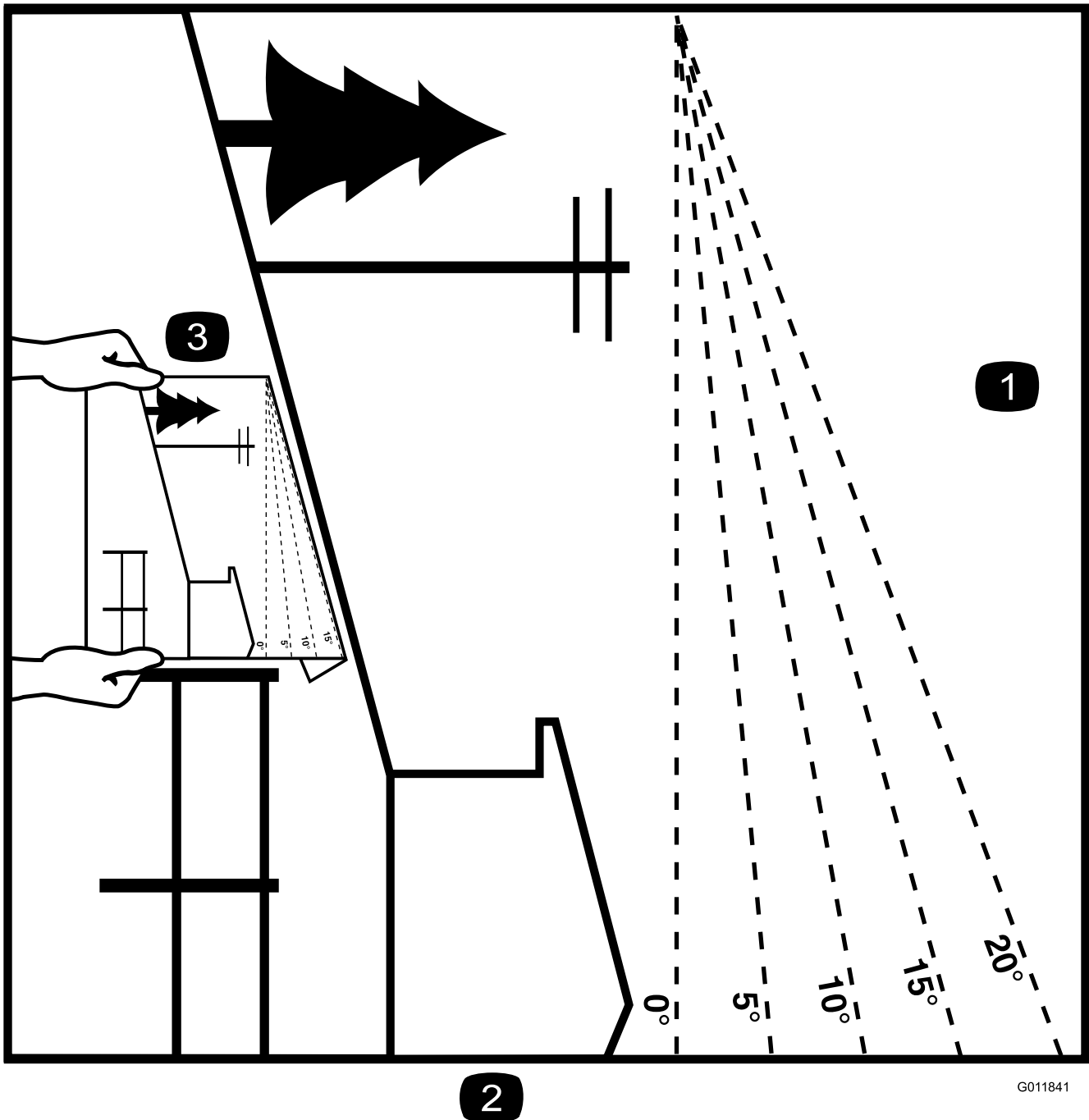

G011841

2

Figure 3

This page may be copied for personal use.

1. The maximum slope you can safely operate the machine on is **15 degrees**. Use the slope chart to determine the degree of slope of hills before operating. **Do not operate this machine on a slope greater than 15 degrees.** Fold along the appropriate line to match the recommended slope.
2. Align this edge with a vertical surface, a tree, building, fence pole, etc.
3. Example of how to compare slope with folded edge.

Safety and Instructional Decals



Safety decals and instructions are easily visible to the operator and are located near any area of potential danger. Replace any decal that is damaged or lost.



1. Grease

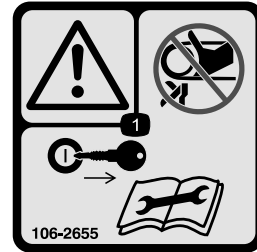

106-2655

1. Warning—do not touch or approach moving belts; remove the ignition key and read the instructions before servicing or performing maintenance.

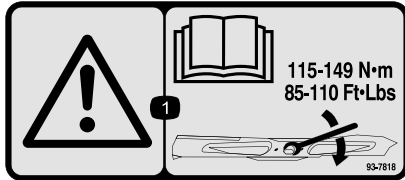

93-7818

1. Warning—read the *Operator's Manual* for instructions on torquing the blade bolt/nut to 115-149 N-m (85-110 ft-lb).



106-5517

1. Warning—do not touch the hot surface.

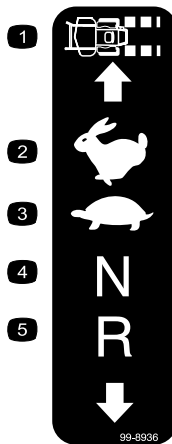

99-8936

- | | |
|------------------|------------|
| 1. Machine speed | 4. Neutral |
| 2. Fast | 5. Reverse |
| 3. Slow | |



107-3069

1. Warning—there is no rollover protection when the roll bar is down.
2. To avoid injury or death from a rollover accident, keep the roll bar in the fully raised and locked position and wear the seat belt. Lower the roll bar only when absolutely necessary; do not wear the seat belt when the roll bar is down.
3. Read the *Operator's manual*; drive slowly and carefully.

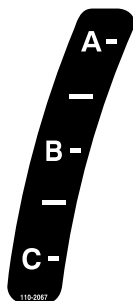

110-2067

ADJUSTABLE BAFFLE BAFLE AJUSTABLE

A -	<ul style="list-style-type: none"> • Short, light grass • Dry conditions • Maximum dispersion 		<ul style="list-style-type: none"> • Césped corto y ligero • Condiciones secas • Maxima dispersion
B -	<ul style="list-style-type: none"> • Bagging setting 		<ul style="list-style-type: none"> • Posicion para usar con bolsa
C -	<ul style="list-style-type: none"> • Tall, dense grass • Wet conditions • Maximum ground speed 		<ul style="list-style-type: none"> • Césped alto y denso • Condiciones mojadas • Maxima velocidad

110-2068 1

110-2068

1. Read the *Operator's Manual*.

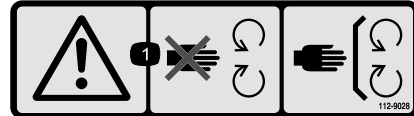

112-9028

1. Warning—stay away from moving parts; keep all guards in place.

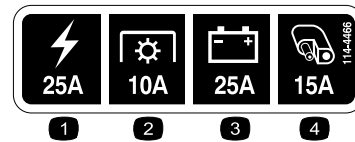

114-4466

- | | |
|--------------|-------------------|
| 1. Main, 25A | 3. Charge, 25A |
| 2. PTO, 10A | 4. Auxiliary, 15A |

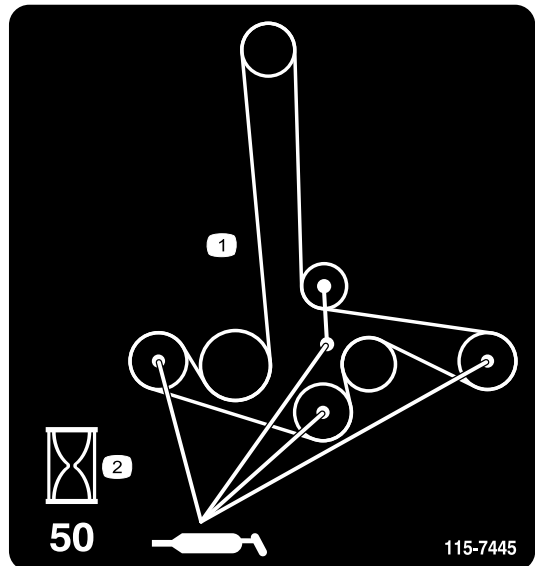

115-7445

1. Grease pulleys and spindles
2. Maintenance interval—50 hours

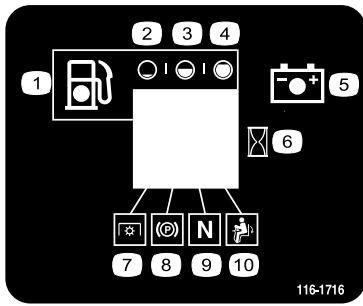

116-1716

- | | |
|------------|------------------------------|
| 1. Fuel | 6. Hour meter |
| 2. Empty | 7. PTO |
| 3. Half | 8. Parking brake |
| 4. Full | 9. Neutral |
| 5. Battery | 10. Operator presence switch |

CALIFORNIA SPARK ARRESTER WARNING

Operation of this equipment may create sparks that can start fires around dry vegetation. A spark arrester may be required. The operator should contact local fire agencies for laws or regulations relating to fire prevention requirements.

116-4858

116-4858

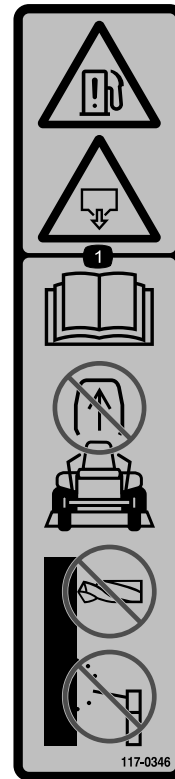

117-0346

1. Fuel leak hazard—read the *Operator's Manual*; do not attempt to remove the roll bar; do not weld, drill or modify the roll bar in any way.

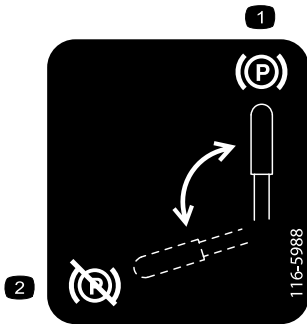

116-5988

1. Parking brake—engaged
2. Parking brake—disengaged



116-8726

1. Read the Operator's Manual for recommended hydro oil.



117-3848

1. Thrown object hazard—keep bystanders a safe distance from the machine
2. Thrown object hazard, mower—do not operate without the deflector, discharge cover or grass collection system in place.
3. Cutting/dismemberment of hand or foot—stay away from moving parts; keep all guards and shields in place.

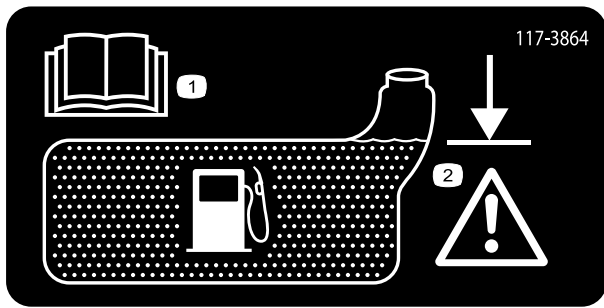

117-3864

1. Read the *Operator's Manual*.
2. Fill to bottom of filler neck; warning—do not overfill the tank.

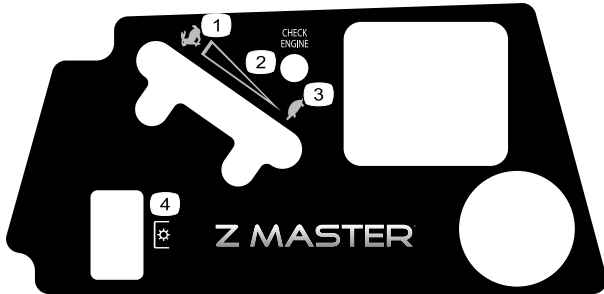

121-7586

1. Fast
2. Variable speed control
3. Slow
4. Power take-off (PTO)



126-2055

1. Wheel lug nut torque 95 ft-lb (129 N-m) (4x)
2. Wheel hub nut torque 235 ft-lb (319 N-m)
3. Read and understand the Operator's manual before performing any maintenance, check torque after first 100 hours then every 500 hours thereafter.

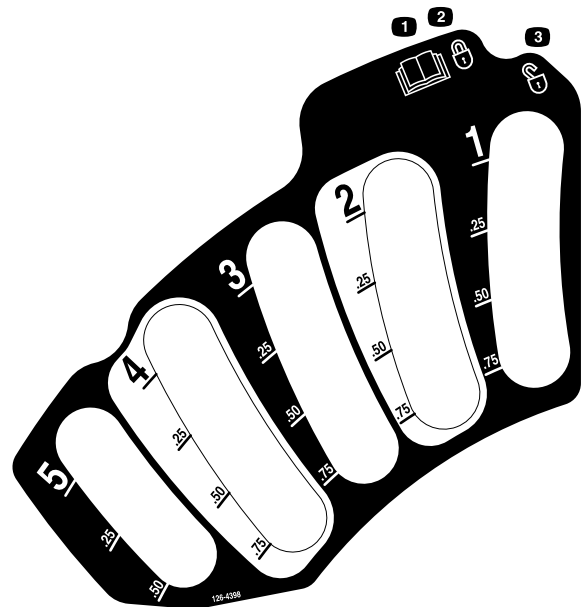

126-4398

1. Read the *Operator's manual*
2. Lock
3. Unlock

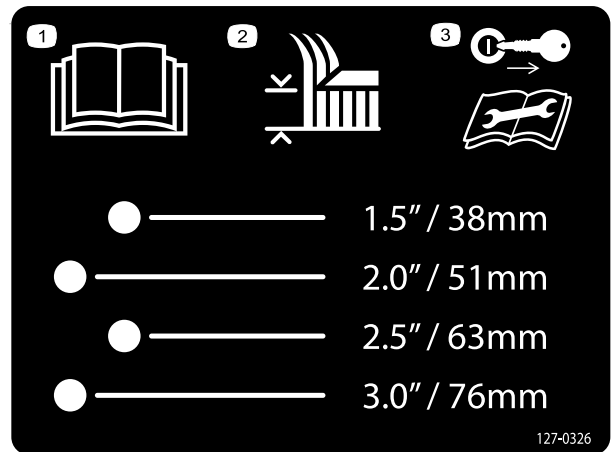

127-0326

1. Read the *Operator's Manual*.
2. Height-of-cut
3. Remove the key from the ignition and read the *Operator's Manual* before performing maintenance or servicing the machine.



131-4036

1. Maximum drawbar pull 36 kg (80 lb)
2. Read the *Operator's Manual*.



Battery Symbols

Some or all of these symbols are on your battery

- | | |
|--|--|
| 1. Explosion hazard | 6. Keep bystanders a safe distance from the battery. |
| 2. No fire, open flame, or smoking. | 7. Wear eye protection; explosive gases can cause blindness and other injuries |
| 3. Caustic liquid/chemical burn hazard | 8. Battery acid can cause blindness or severe burns. |
| 4. Wear eye protection | 9. Flush eyes immediately with water and get medical help fast. |
| 5. Read the <i>Operator's Manual</i> . | 10. Contains lead; do not discard. |

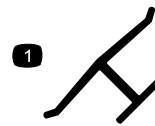

Manufacturer's Mark

1. Indicates the blade is identified as a part from the original machine manufacturer.

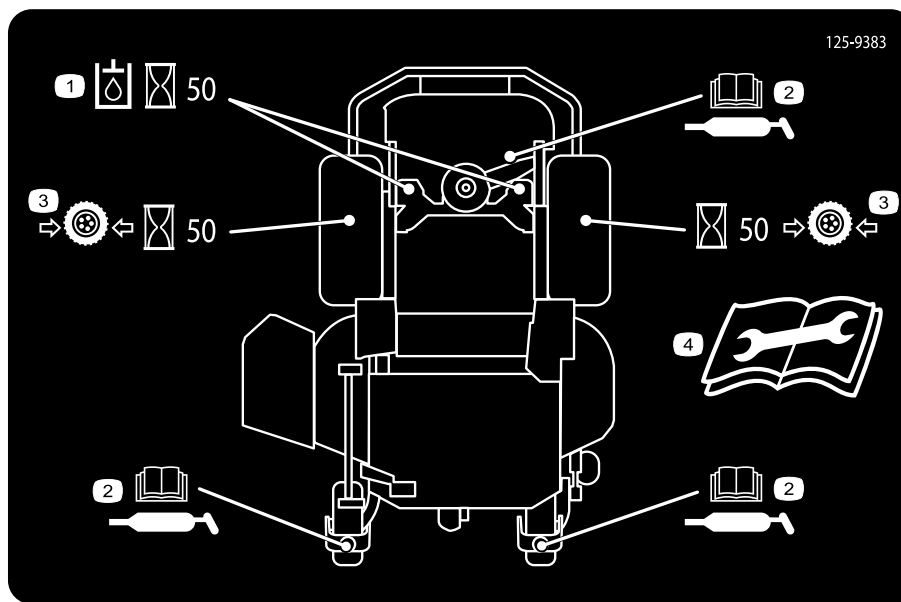

125-9383

- | | |
|--|--|
| 1. Check hydraulic oil every 50 operating hours. | 3. Check the tire pressure every 50 operating hours. |
| 2. Read the <i>Operator's Manual</i> for information on lubricating the machine. | 4. Read the <i>Operator's Manual</i> before servicing or performing maintenance. |

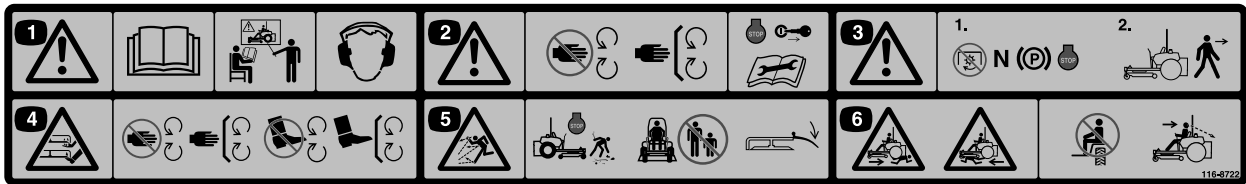

116-8722

1. Warning-Read the *Operator's Manual*. Do Not operate this machine unless you are trained. Wear hearing protection.
2. Warning-Stay away from moving parts; keep all guards in place. Stop engine and remove key before adjusting, servicing, or cleaning.
3. Warning-Disengage PTO, move drive levers out to neutral lock position, engage parking brake, and stop engine before leaving the operator's position.
4. Cutting/dismemberment of hand or foot-stay away from moving parts; keep all guards and shields in place.
5. Thrown object hazard-Pick up objects that could be thrown by mower. Do not operate when people and pets are in the area. Keep deflector in place.
6. Crushing/dismemberment hazard of bystanders - do not carry passengers, look forward and down when operating the machine, look behind and down when reversing.

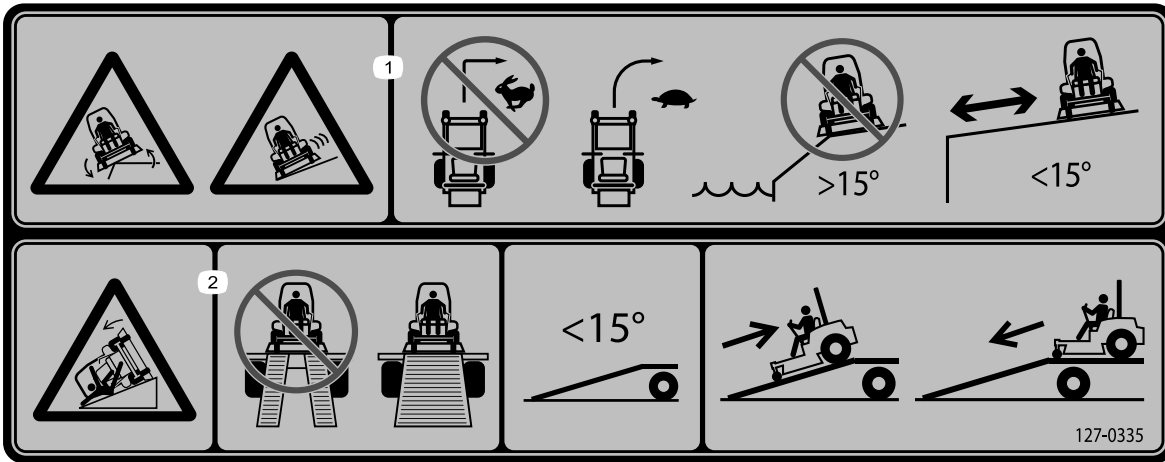

127-0335

1. Tipping hazard on slopes—do not make sudden, tight turns; make slow, wide turns; do not use on slopes near open water; do not use this machine on slopes greater than 15 degrees.
2. Ramp hazard—when loading onto a trailer, do not use dual ramps; only use a singular ramp wide enough for the machine and that has an incline less than 15 degrees; back up the ramp (in reverse) and drive forward off the ramp.

Product Overview

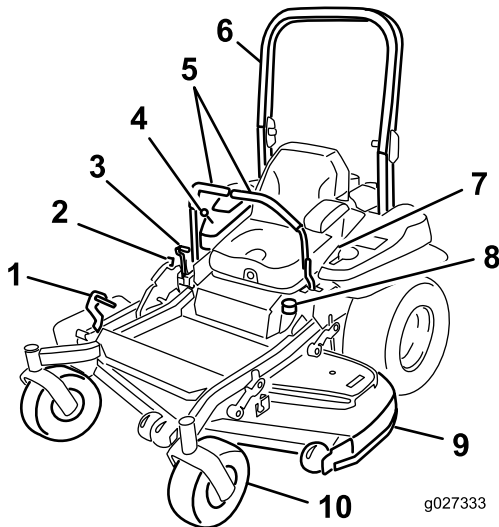

Figure 4

- | | |
|----------------------------------|------------------|
| 1. Height-of-cut deck lift pedal | 6. Roll bar |
| 2. Transport lock | 7. Seat belt |
| 3. Parking brake lever | 8. Fuel cap |
| 4. Controls | 9. Mower deck |
| 5. Motion-control levers | 10. Caster wheel |

Controls

Become familiar with all the controls before you start the engine and operate the machine (Figure 4 and Figure 5).

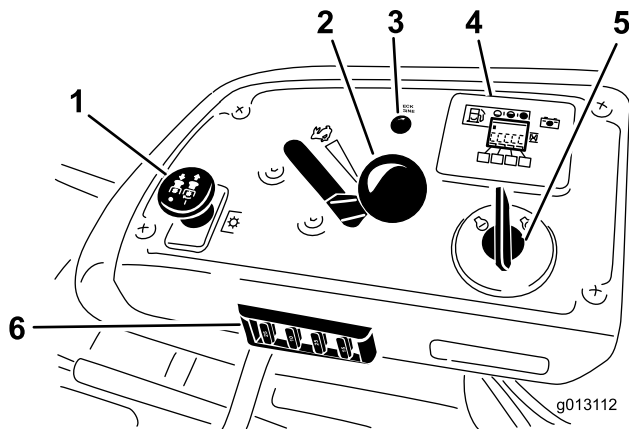

Figure 5

- | | |
|--------------------------------------|---|
| 1. PTO Switch | 4. Hour meter/Safety-interlock display/Fuel gauge |
| 2. Throttle control | 5. Ignition switch |
| 3. Malfunction indicator light (MIL) | 6. Fuses |

Fuel Gauge

The fuel gauge is located with the hour meter, and the bars light up when the ignition switch is on (Figure 6).

The indicator light appears when the fuel level is low—approximately 3.8 L (1 US gallon) remaining in the fuel tank.

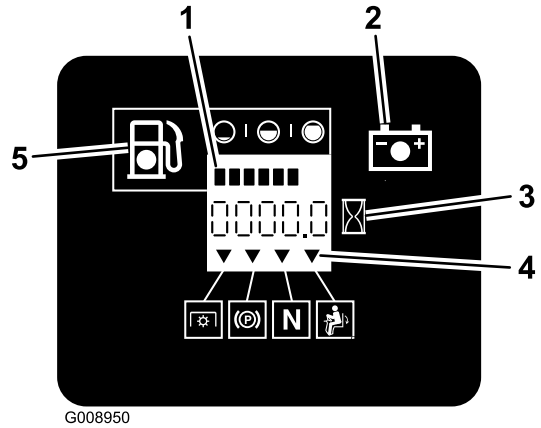

Figure 6

- | | |
|----------------------|-----------------------------|
| 1. Fuel gauge (bars) | 4. Safety-interlock symbols |
| 2. Battery light | 5. Low-fuel indicator light |
| 3. Hour meter | |

Hour Meter

The hour meter records the number of hours the engine has operated. It operates when the engine is running. Use these times for scheduling regular maintenance (Figure 6).

Safety-Interlock Indicators

There are symbols on the hour meter and the indicate with a black triangle that the interlock component is in the correct position (Figure 6).

Battery Indicator Light

When the ignition key is initially turned to the **Run** position for a few seconds, the battery voltage will be displayed in the area where the hours are normally displayed.

The battery light turns on when the ignition is turned on and when the charge is below the correct operating level (Figure 6).

Throttle Control

The throttle control is variable between **Fast** and **Slow**.

Blade-Control Switch (PTO)

The blade-control switch (PTO) is used to engage the electric clutch and drive the mower blades. Pull the switch up to engage the blades and release. To disengage the blades, push the blade-control switch (PTO) down or move a motion-control lever into the neutral lock position.

Ignition Switch

This switch is used to start the mower engine and has three positions: **Start**, **Run** and **Off**.

Motion-Control Levers

The motion-control levers are used to drive the machine forward, reverse, and turn either direction.

Neutral-Lock Position

The neutral-lock position is used with the safety-interlock system to engage and to determine neutral position.

Fuel-Shutoff Valve

Close the fuel-shutoff valve (under the seat) when transporting or storing the mower.

Electronic Control Unit Malfunction Indicator Light

The electronic control unit (ECU) continuously monitors the operation of the EFI system.

If the system detects a problem or fault, the malfunction indicator light (MIL) illuminates.

The MIL is the red light located in the right console panel.

If the MIL illuminates, perform the initial troubleshooting checks; refer to the MIL section in [Troubleshooting \(page 66\)](#).

If these checks do not correct the problem, further diagnosis and servicing by an Authorized Service Dealer is necessary.

Attachments/Accessories

A selection of Toro approved attachments and accessories is available for use with the machine to enhance and expand its capabilities. Contact your Authorized Service Dealer or Distributor or go to www.Toro.com for a list of all approved attachments and accessories.

Specifications

Note: Specifications and design are subject to change without notice.

Width:

	52-inch Deck	60-inch Deck	72-inch Deck
Without Deck	116 cm (46 inches)	134.6 cm (53.0 inches)	150.1 cm (59.1 inches)
Deflector Up	146 cm (58 inches)	156.8 cm (61.7 inches)	187 cm (73.6 inches)
Deflector Down	172 cm (68 inches)	192.2 cm (75.7 inches)	222.4 cm (87.6 inches)

Length:

	52-inch Deck	60-inch Deck	72-inch Deck
Roll Bar—Up	201 cm (79 inches)	211.1 cm (83.1 inches)	218.7 cm (86.1 inches)
Roll Bar—Down	206 cm (81 inches)	215.4 cm (84.8 inches)	223.0 cm (87.8 inches)

Height:

Roll Bar—Up	Roll Bar—Down
179.1 cm (70.5 inches)	118.9 cm (46.8 inches)

Weight:

Model	Weight
74906	533 kg (1174 lbs)
74926, 78926, and 74930	569 kg (1255 lb)
74918, 74928, and 78928	612 kg (1350 lb)

Operation

Note: Determine the left and right sides of the machine from the normal operating position.

Adding Fuel

- For best results, use only clean, fresh (less than 30 days old), unleaded gasoline with an octane rating of 87 or higher ((R+M)/2 rating method).
- **Ethanol:** Gasoline with up to 10% ethanol (gasohol) or 15% MTBE (methyl tertiary butyl ether) by volume is acceptable. Ethanol and MTBE are not the same. Gasoline with 15% ethanol (E15) by volume is not approved for use. **Never use** gasoline that contains more than 10% ethanol by volume, such as E15 (contains 15% ethanol), E20 (contains 20% ethanol), or E85 (contains up to 85% ethanol). Using unapproved gasoline may cause performance problems and/or engine damage which may not be covered under warranty.
- **Do not** use gasoline containing methanol.
- **Do not** store fuel either in the fuel tank or fuel containers over the winter unless a fuel stabilizer is used.
- **Do not** add oil to gasoline.

▲ DANGER

In certain conditions, gasoline is extremely flammable and highly explosive. A fire or explosion from gasoline can burn you and others and can damage property.

- Fill the fuel tank outdoors, in an open area, when the engine is cold. Wipe up any gasoline that spills.
- Never fill the fuel tank inside an enclosed trailer.
- Do not fill the fuel tank completely full. Add gasoline to the fuel tank until the level is 6 to 13 mm (1/4 to 1/2 inch) below the bottom of the filler neck. This empty space in the tank allows gasoline to expand.
- Never smoke when handling gasoline, and stay away from an open flame or where gasoline fumes may be ignited by a spark.
- Store gasoline in an approved container and keep it out of the reach of children. Never buy more than a 30-day supply of gasoline.
- Do not operate without the entire exhaust system in place and in proper working condition.

▲ DANGER

In certain conditions during fueling, static electricity can cause a spark which can ignite the gasoline vapors. A fire or explosion from gasoline can burn you and others and can damage property.

- Always place gasoline containers on the ground away from your vehicle before filling.
- Do not fill gasoline containers inside a vehicle or on a truck or trailer bed, because interior carpets or plastic truck-bed liners may insulate the container and slow the loss of any static charge.
- When practical, remove gas-powered equipment from the truck or trailer and fuel the equipment with the wheels on the ground.

If this is not possible, then fuel such equipment on a truck or trailer from a portable container, rather than from a gasoline-dispenser nozzle.

- If a gasoline dispenser must be used, keep the nozzle in contact with the rim of the fuel tank or container opening at all times until fueling is complete.

▲ WARNING

Gasoline is harmful or fatal if swallowed. Long-term exposure to vapors can cause serious injury and illness.

- Avoid prolonged breathing of vapors.
- Keep face away from nozzle and gas tank or conditioner bottle opening.
- Avoid contact with skin; wash off spillage with soap and water.

Using Fuel Stabilizer/Conditioner

Use a fuel stabilizer/conditioner in the machine to keep the fuel fresh during storage of 90 days or less. If you are storing the machine for longer, drain the fuel tank; refer to [Storage \(page 65\)](#).

Important: Do not use fuel additives containing methanol or ethanol.

Add the correct amount of fuel stabilizer/conditioner to the fuel, and follow the directions of the manufacturer.

Note: Fuel stabilizer/conditioner is most effective when mixed with fresh gasoline. To minimize the chance of varnish deposits in the fuel system, use fuel stabilizer at all times.

Filling the Fuel Tank

1. Park the machine on level ground.
2. Shut the engine off and set the parking brake.
3. Clean around the fuel-tank cap and remove it. Add regular unleaded gasoline to the fuel tank until the level is 6 to 13 mm (1/4 to 1/2 inch) below the bottom of the filler neck. This space in the tank allows the gasoline to expand. Do not fill the fuel tank completely full; refer to (Figure 7).

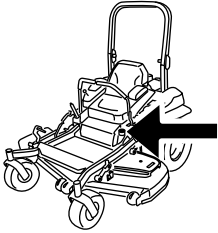

G009189

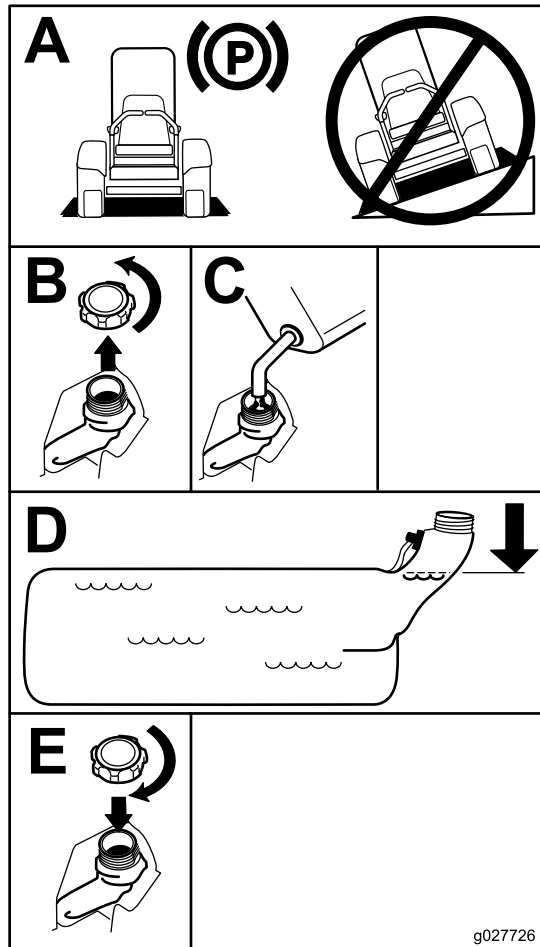

Figure 7

Breaking in a New Machine

New engines take time to develop full power. Mower decks and drive systems have higher friction when new, placing additional load on the engine. Allow 40 to 50 hours of break-in time for new machines to develop full power and best performance.

Using the Rollover Protection System (ROPS)

⚠ WARNING

To avoid injury or death from rollover: keep the roll bar in the fully raised locked position and use the seat belt.

Ensure that the rear part of the seat is secured with the seat latch.

⚠ WARNING

There is no rollover protection when the roll bar is in the down position.

- Lower the roll bar only when absolutely necessary.
- Do not wear the seat belt when the roll bar is in the down position.
- Drive slowly and carefully.
- Raise the roll bar as soon as clearance permits.
- Check carefully for overhead clearances (i.e. branches, doorways, electrical wires) before driving under any objects and do not contact them.

Important: Lower the roll bar only when absolutely necessary.

1. To lower the roll bar, apply forward pressure to the upper part of the roll bar.
2. Pull both knobs out and rotate them 90° so that they are not engaged (Figure 8).
3. Lower the roll bar to the down position (Figure 8).

Checking the Engine-Oil Level

Before you start the engine and use the machine, check the oil level in the engine crankcase; refer to [Checking the Engine-Oil Level](#) (page 35).

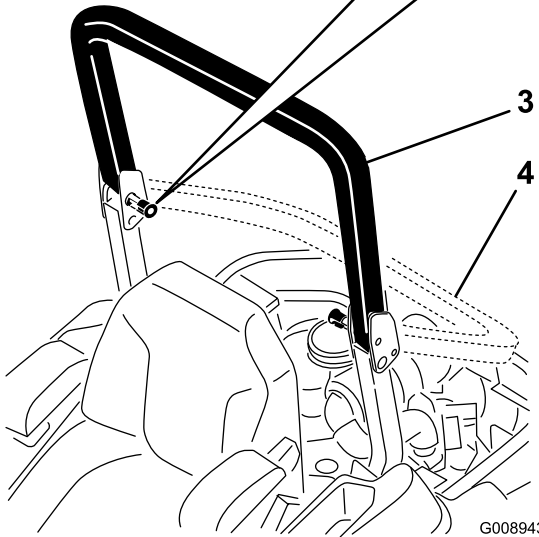
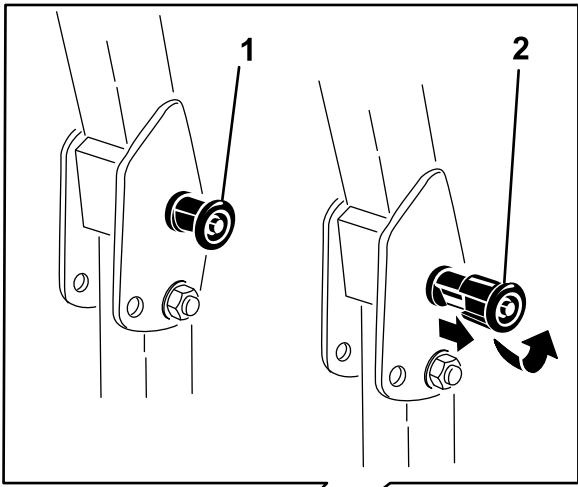

Figure 8

- | | |
|---|-------------------------------------|
| 1. ROPS knob | 3. Roll bar in the upright position |
| 2. Pull ROPS knob out and rotate 90 degrees | 4. Roll bar in the folded position |

- To raise the roll bar, raise the roll bar to the operate position, rotate the knobs so that they move partially into the grooves (Figure 8).
- Raise the roll bar to the full upright position while pushing on the upper roll bar and the pins will snap into position when the holes align with the pins (Figure 8). Push on the roll bar and ensure that both pins are engaged.

Important: Always use the seat belt with the roll bar in the fully raised position.

Think Safety First

Please read all safety instructions and symbols in the safety section. Knowing this information could help you or bystanders avoid injury.

⚠ DANGER

Operating on wet grass or steep slopes can cause sliding and loss of control.

Wheels dropping over edges can cause rollovers, which may result in serious injury, death, or drowning.

There is no rollover protection when the roll bar is down.

Always keep the roll bar in the fully raised and locked position and use the seat belt.

Read and follow the rollover protection instructions and warnings.

To avoid loss of control and possibility of rollover:

- Do not operate near drop-offs or near water.
- Do not operate on slopes greater than 15 degrees.
- Reduce speed and use extreme caution on slopes.
- Avoid sudden turns or rapid speed changes.

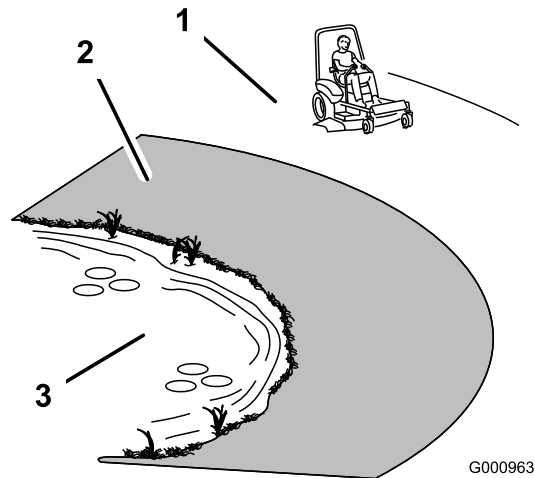

Figure 9

- | | |
|--|----------|
| 1. Safe Zone-use the Z Master here on slopes less than 15 degrees or flat areas. | 3. Water |
| 2. Danger Zone- use a walk behind mower and/or a hand trimmer on slopes greater than 15 degrees, near drop-offs and water. | |

⚠ CAUTION

This machine produces sound levels in excess of 85 dBA at the operator's ear and can cause hearing loss through extended periods of exposure.

Wear hearing protection when operating this machine.

The use of protective equipment for eyes, ears, feet, and head is recommended.

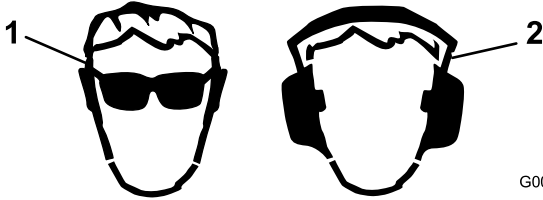

Figure 10

G009027

1. Wear safety glasses
2. Wear hearing protection

Operating the Parking Brake

Always set the parking brake when you stop the machine or leave it unattended.

Setting the Parking Brake

⚠ WARNING

The parking brake may not hold machine parked on a slope and could cause personal injury or property damage.

Do not park on slopes unless the wheels are chocked or blocked.

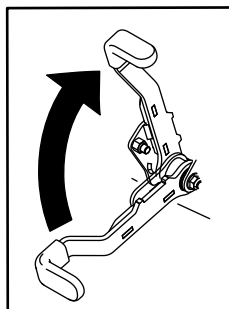
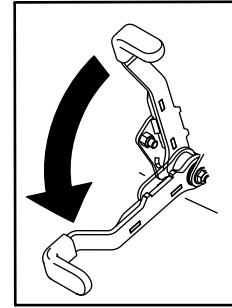

Figure 11

g027334

Releasing the Parking Brake



g027335

Figure 12

Operating the Mower Blade-Control Switch (PTO)

The blade-control switch (PTO) starts and stops the mower blades and any powered attachments.

Engaging the Blade-Control Switch (PTO)

Note: Engaging the blade-control switch (PTO) with the throttle position at half or less will cause excessive wear to the drive belts.

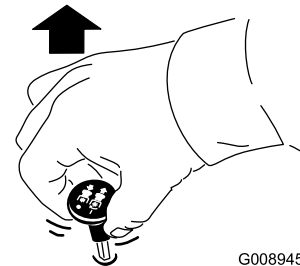

G008945

Figure 13

Disengaging the Blade-Control Switch (PTO)

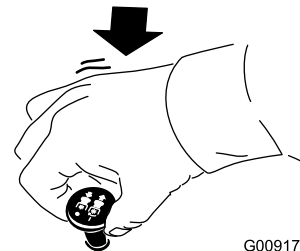

G009174

Figure 14

Operating the Throttle

The throttle control can be moved between **Fast** and **Slow** positions (Figure 15).

Always use the fast position when turning on the mower deck with the blade-control switch (PTO).

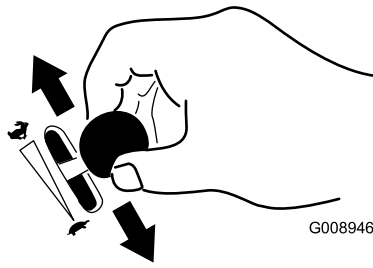

Figure 15

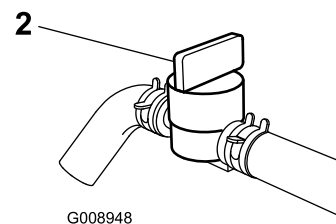
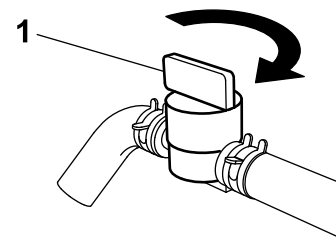

Figure 17

1. On

2. Off

Operating the Ignition Switch

1. Turn the ignition key to the Start position (Figure 16). When the engine starts, release the key.

Important: Do not engage the starter for more than 5 seconds at a time. If the engine fails to start, allow a 15 second cool-down period between attempts. Failure to follow these instructions can burn out the starter motor.

Note: Additional starting cycles may be required when starting the engine for the first time after the fuel system has been completely without fuel.

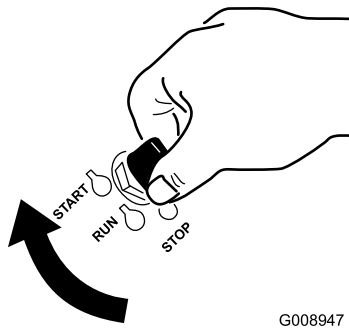

Figure 16

2. To stop the engine, turn the ignition key to the stop position.

Using the Fuel-Shutoff Valve

The fuel-shutoff valve is located under the seat. Move the seat forward to access it.

Close the fuel-shutoff valve for transport, maintenance, and storage.

Ensure that the fuel-shutoff valve is open when starting the engine.

Starting and Stopping the Engine

Starting the Engine

1. Raise the ROPS up and lock into place, sit on the seat and fasten the seat belt.
2. Move the motion controls to neutral-locked position.
3. Set the parking brake; refer to Setting the Parking Brake.
4. Move the blade-control switch (PTO) to the Off position (Figure 18).
5. Move the throttle lever midway between the Slow and Fast positions.

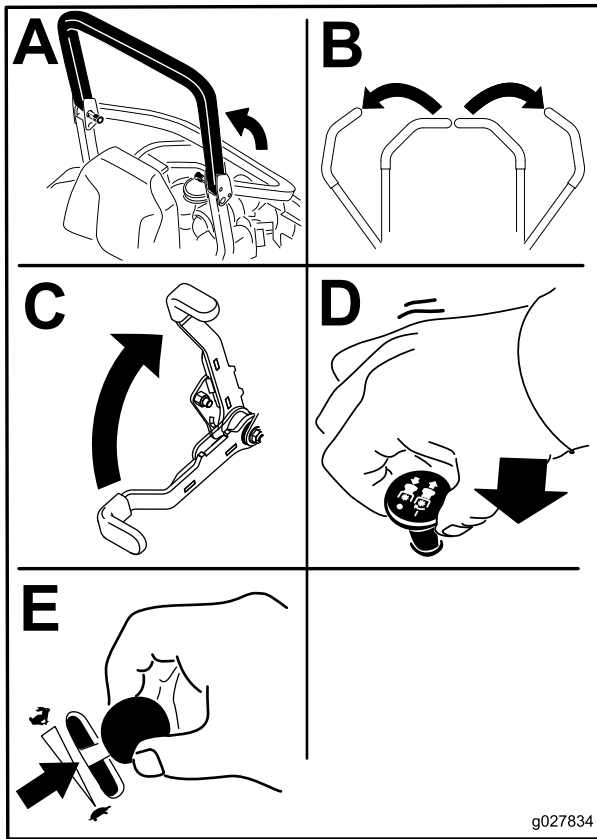

Figure 18

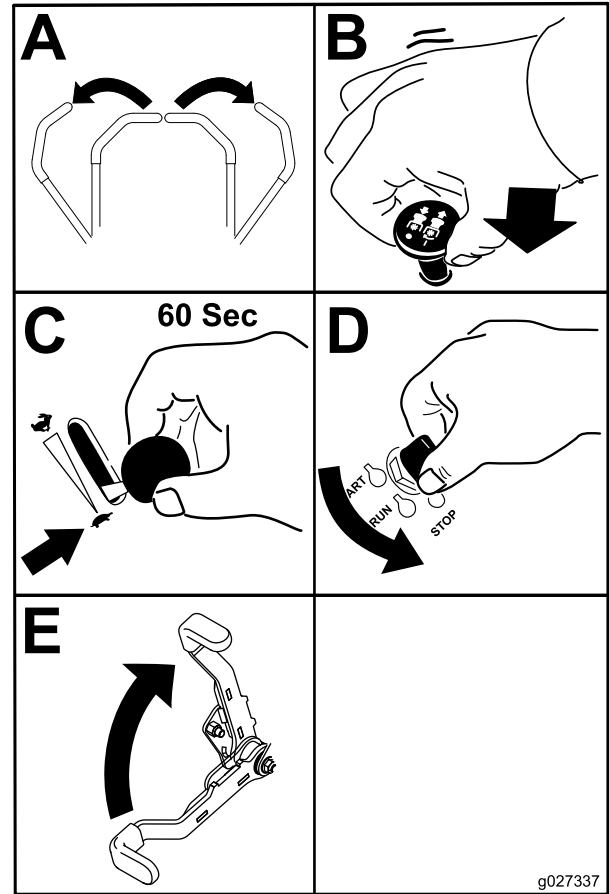

Figure 19

- Turn the ignition key to the Start position (Figure 16). When the engine starts, release the key.

Stopping the Engine

⚠ CAUTION

Children or bystanders may be injured if they move or attempt to operate the machine while it is unattended.

Always remove the ignition key and set the parking brake when leaving the machine unattended, even if just for a few minutes.

Let the engine idle at slow throttle (turtle) for 60 seconds before turning the ignition switch off.

Important: Make sure that the fuel shut off valve is closed before transporting or storing the machine, as fuel leakage may occur. Set the parking brake before transporting. Make sure to remove the key as the fuel pump may run and cause the battery to lose charge.

The Safety-Interlock System

⚠ CAUTION

If safety-interlock switches are disconnected or damaged the machine could operate unexpectedly causing personal injury.

- Do not tamper with the interlock switches.
- Check the operation of the interlock switches daily and replace any damaged switches before operating the machine.

Understanding the Safety-Interlock System

The safety-interlock system is designed to prevent the engine from starting unless:

- The parking brake is engaged.

- The blade-control switch (PTO) is disengaged.
- The motion-control levers are in the neutral-locked position

The safety-interlock system also is designed to stop the engine when the traction controls are moved from the locked position with the parking brake engaged or if you rise from the seat when the PTO is engaged.

The hour meter has symbols to notify the user when the interlock component is in the correct position. When the component is in the correct position, a triangle will light up in the corresponding square.

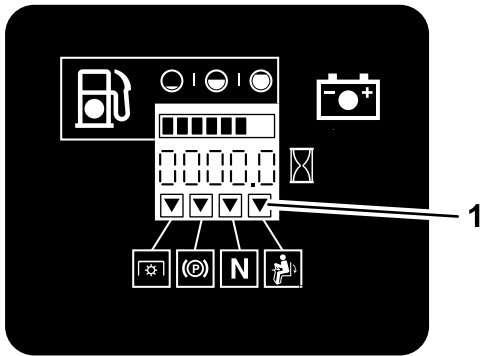

G009181

Figure 20

1. Triangles light up when the interlock components are in the correct position

Testing the Safety-Interlock System

Service Interval: Before each use or daily

Test the safety-interlock system before you use the machine each time. If the safety system does not operate as described below, have an Authorized Service Dealer repair the safety system immediately.

1. Sitting on the seat, engage the parking brake and move the blade-control switch (PTO) to on. Try starting the engine; the engine should not crank.
2. Sitting on the seat, engage the parking brake and move the blade-control switch (PTO) to off. Move either motion-control lever (out of neutral-locked position). Try starting the engine; the engine should not crank. Repeat for other control lever.
3. Sitting on the seat, engage the parking brake, move the blade-control switch (PTO) to off and move the motion-control levers to neutral lock position. Now start the engine. While the engine is running, release the parking brake, engage the blade-control switch (PTO) and rise slightly from the seat; the engine should stop.
4. Sitting on the seat, engage the parking brake, move the blade-control switch (PTO) to off and move the motion-control levers to neutral lock position. Now start the engine. While the engine is running, center either motion control and move (forward or reverse);

the engine should stop. Repeat for other motion control.

5. Sitting on the seat, disengage the parking brake, move the blade-control switch (PTO) to off and move the motion-control levers to neutral lock position. Try starting the engine; the engine should not crank.

Driving Forward or Backward

The throttle control regulates the engine speed as measured in rpm (revolutions per minute). Place the throttle control in the fast position for best performance. Always operate in the full throttle position when mowing.

CAUTION

Machine can spin very rapidly. Operator may lose control of machine and cause personal injury or damage to machine.

- Use caution when making turns.
- Slow the machine down before making sharp turns.

Using the Motion-Control Levers

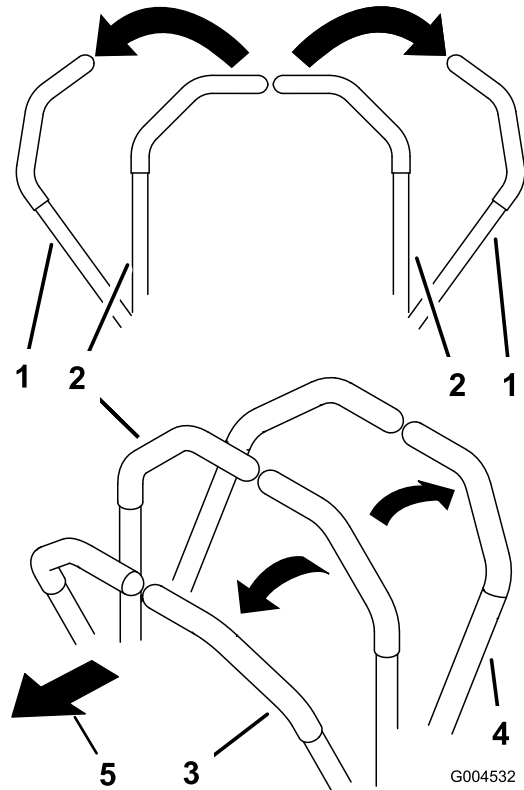

G004532

Figure 21

1. motion-control lever—neutral-lock position
2. Center, unlocked position
3. Forward
4. Backward
5. Front of machine

Driving Forward

Note: The engine will kill if the traction control levers are moved with the parking brake engaged.

To stop, pull the motion-control levers to the neutral position.

1. Release the parking brake; refer to Releasing the Parking Brake in Operation.
2. Move the levers to the center, unlocked position.
3. To go forward, slowly push the motion-control levers forward (Figure 22).

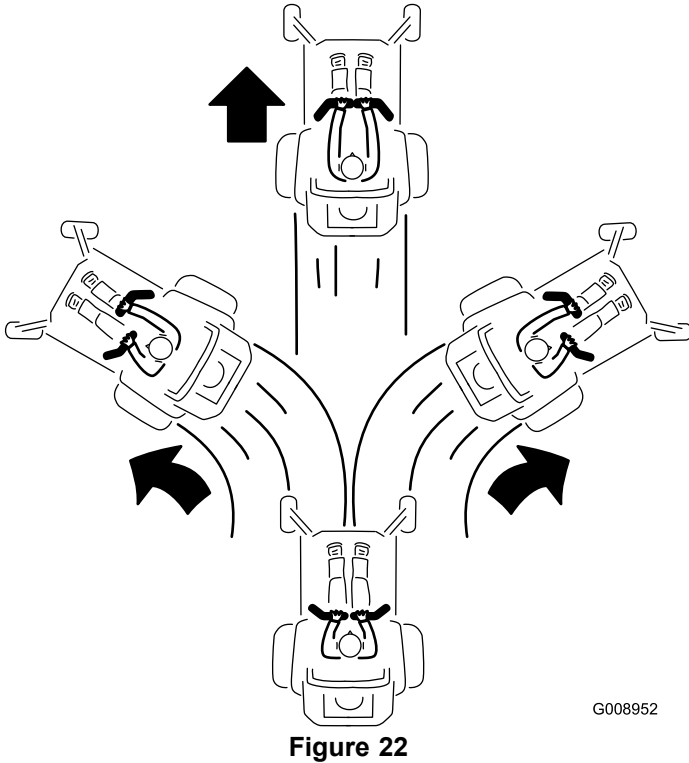

Figure 22

Driving Backward

1. Move the levers to the center, unlocked position.
2. To go backward, look behind and slowly pull the motion-control levers rearward (Figure 23).

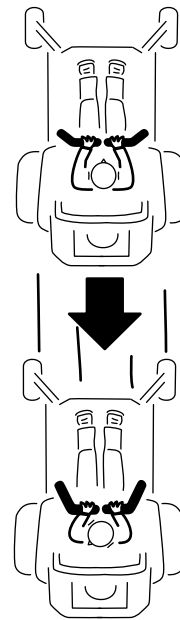

Figure 23

Stopping the Machine

To stop the machine, move the traction control levers to neutral and to the locked position, disengage the power take-off (blade-control switch (PTO)), and turn the ignition key to off.

Set the parking brake when you leave the machine; refer to Setting the Parking Brake in Operation. Remember to remove the key from the ignition switch.

⚠ CAUTION

Children or bystanders may be injured if they move or attempt to operate the machine while it is unattended.

Always remove the ignition key and set the parking brake when leaving the machine unattended, even if just for a few minutes.

Adjusting the Height of Cut

Using the Transport Lock

The transport lock has 2 positions and is used with the deck lift pedal. There is a lock position and an unlock position for the transport position. The transport lock is used with the deck lift pedal. Refer to Figure 24

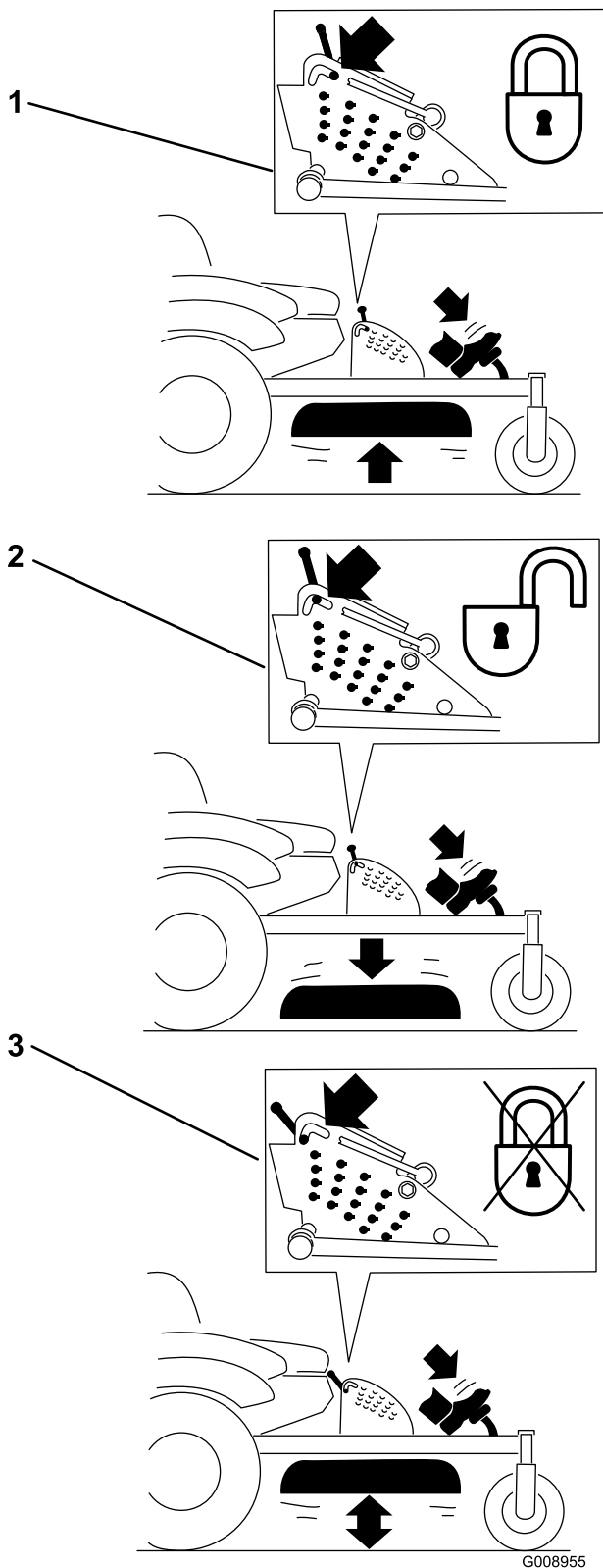

Figure 24
Transport lock positions

1. Transport lock
2. Lock position—mower deck will lock into transport position
3. Unlock position—does not lock the mower deck into transport position

Adjusting the Height-of-Cut Pin

The height of cut is adjusted from 25 to 140 mm (1 to 5-1/2 inches) in 6 mm (1/4 inch) increments by moving the clevis pin into different hole locations.

1. Move the transport lock to the lock position.
2. Push on the deck lift pedal with your foot, and raise the mower deck to the transport position (also the 140 mm (5-1/2 inch) cutting-height position); refer to [Figure 25](#).
3. To adjust, rotate the pin 90 degrees and remove the pin from the height-of-cut bracket ([Figure 25](#)).
4. Select a hole in the height-of-cut bracket corresponding to the height of cut desired, and insert the pin ([Figure 25](#)).
5. Push on the deck lift, pull back on the transport lock, and slowly lower the mower deck.

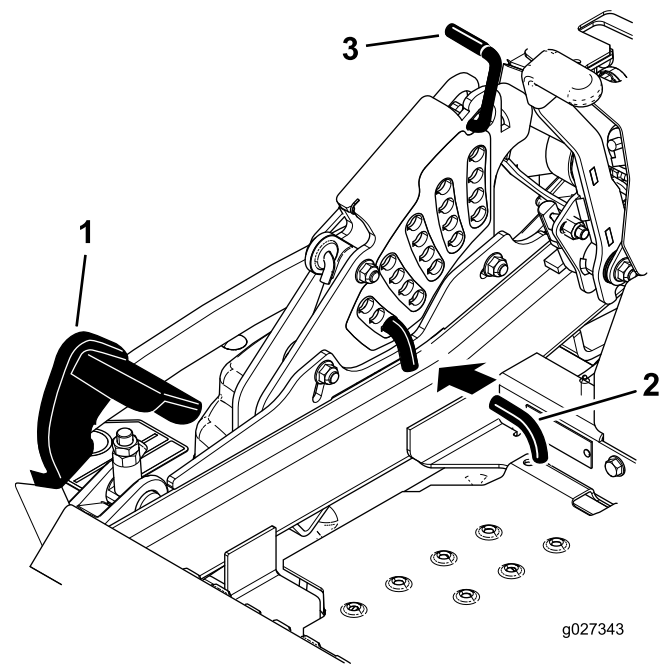

Figure 25

1. Deck lift pedal
2. Height-of-cut pin
3. Transport lock

Adjusting the Anti-Scalp Rollers

Whenever you change the height of cut, it is recommended to adjust the height of the anti-scalp rollers.

1. Disengage the blade-control switch (PTO), move the motion-control levers to the neutral-locked position, and set the parking brake.
2. Stop the engine, remove the key, and wait for all moving parts to stop before leaving the operating position.

ANTI-SCALP ROLLER ADJUSTMENT
 FOR MAXIMUM DECK FLOTATION,
 PLACE ROLLERS IN POSITIONS SHOWN.
 TURN ENGINE OFF BEFORE
 MAKING ROLLER ADJUSTMENTS.

- 1.5" / 38mm
- 2.0" / 51mm
- 2.5" / 63mm
- 3.0" / 76mm

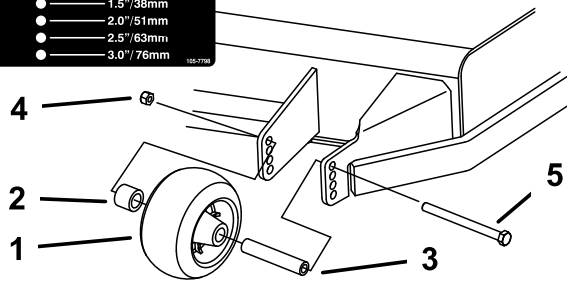

G000942

Figure 26

- | | |
|----------------------|---------------|
| 1. Anti-scalp roller | 4. Flange nut |
| 2. Spacer | 5. Bolt |
| 3. Bushing | |

ANTI-SCALP ROLLER ADJUSTMENT
 FOR MAXIMUM DECK FLOTATION,
 PLACE ROLLERS IN POSITIONS SHOWN.
 TURN ENGINE OFF BEFORE
 MAKING ROLLER ADJUSTMENTS.

- 1.5" / 38mm
- 2.0" / 51mm
- 2.5" / 63mm
- 3.0" / 76mm

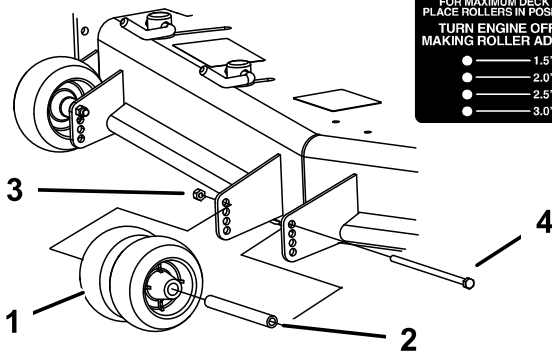

G000943

Figure 27

- | | |
|----------------------|---------------|
| 1. Anti-scalp roller | 3. Flange nut |
| 2. Bushing | 4. Bolt |

ANTI-SCALP ROLLER ADJUSTMENT
 FOR MAXIMUM DECK FLOTATION,
 PLACE ROLLERS IN POSITIONS SHOWN.
 TURN ENGINE OFF BEFORE
 MAKING ROLLER ADJUSTMENTS.

- 1.5" / 38mm
- 2.0" / 51mm
- 2.5" / 63mm
- 3.0" / 76mm

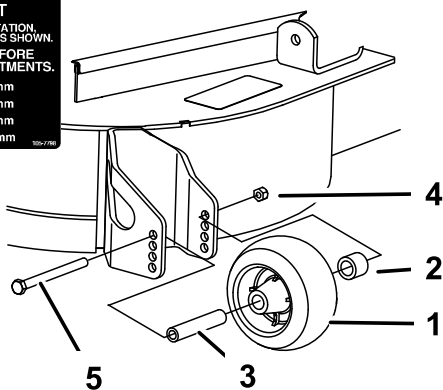

G000944

Figure 28

- | | |
|----------------------|---------------|
| 1. Anti-scalp roller | 4. Flange nut |
| 2. Spacer | 5. Bolt |
| 3. Bushing | |

Adjusting the Flow Baffle Cam Locks

This procedure is applicable only to machines with the flow baffle locks. Certain models will have nuts and bolts in-place of the flow baffle locks and can be adjusted the same.

The mower discharge flow can be adjusted for different types of mowing conditions. Position the cam locks and baffle to give the best quality of cut.

1. Disengage the blade-control switch (PTO), move the motion-control levers to the neutral-locked position and set the parking brake.
2. Stop the engine, remove the key, and wait for all moving parts to stop before leaving the operating position.
3. To adjust the cam locks, swing the lever up to loosen the cam lock (Figure 29).
4. Adjust the baffle and cam locks in the slots to the desired discharge flow.
5. Swing the lever back over to tighten the baffle and cam locks (Figure 29).
6. If the cam locks do not lock the baffle into place or it is too tight, loosen the lever and then rotate the cam lock. Adjust the cam lock until the desired locking pressure is achieved.

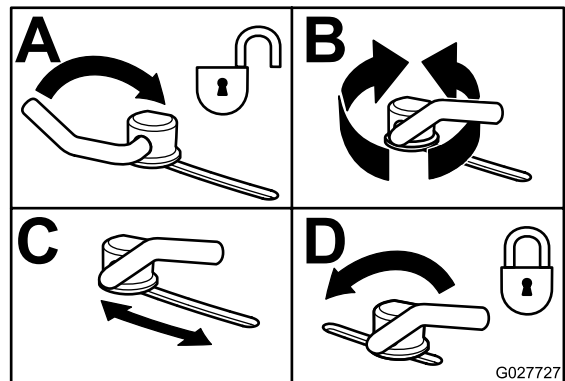

Figure 29

Positioning the Flow Baffle

The following figures are only recommendations for use. Adjustments will vary by grass type, moisture content, and height of grass.

Note: If the engine power draws down and the mower ground speed is the same, open up the baffle.

Position A

This is the full rear position. The suggested use for this position is as follows.

- Use for short, light grass-mowing conditions.
- Use in dry conditions.

- For smaller grass clippings.
- Propels grass clippings farther away from the mower.

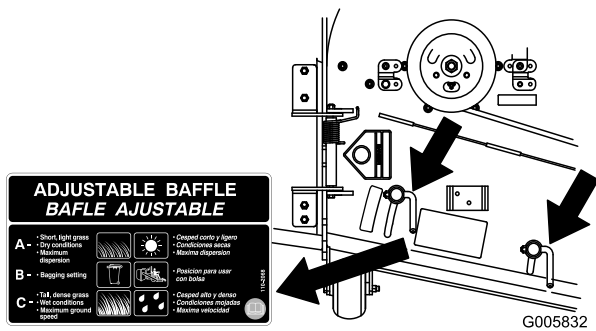

Figure 30

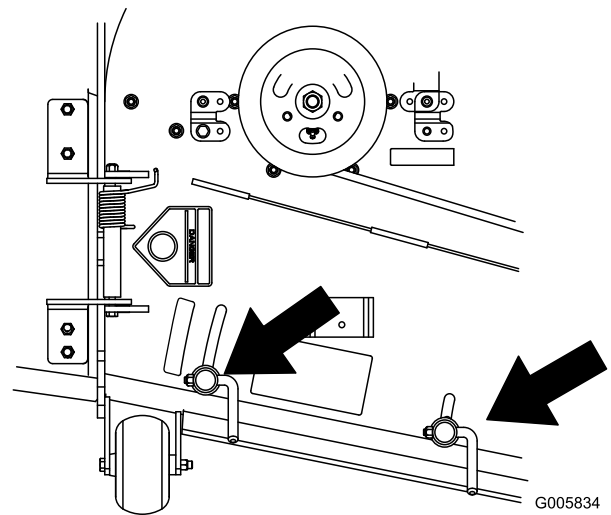

Figure 32

Position B

Use this position when bagging. Always align it with the blower opening.

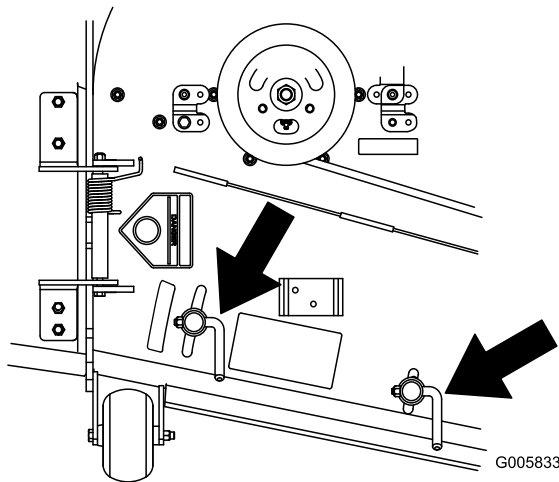

Figure 31

Positioning the Seat

The seat can move forward and backward. Position the seat where you have the best control of the machine and are most comfortable.

To adjust the seat, move the lever sideways to unlock seat and then move the seat forward or backward (Figure 33).

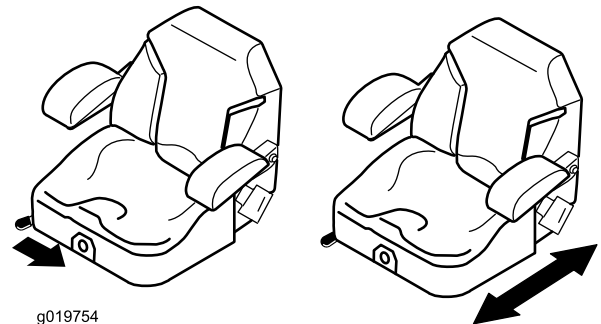

Figure 33

Position C

This is the full open position. The suggested use for this position is as follows.

- Use in tall, dense grass-mowing conditions.
- Use in wet conditions.
- Lowers the engine power consumption.
- Allows increased ground speed in heavy conditions.
- This position is similar to the benefits of the Toro SFS mower.

Unlatching the Seat

Note: Certain models have a fixed seat that does not pivot upward.

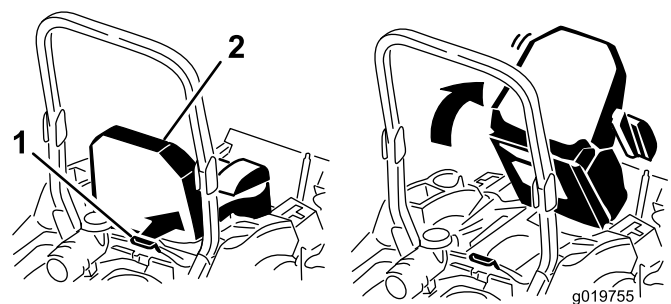

Figure 34

1. Seat latch

2. Seat

Changing the Seat Suspension

The seat is adjustable to provide a smooth and comfortable ride. Position the seat where you are most comfortable.

To adjust it, turn the knob in front either direction to provide the best comfort (Figure 35).

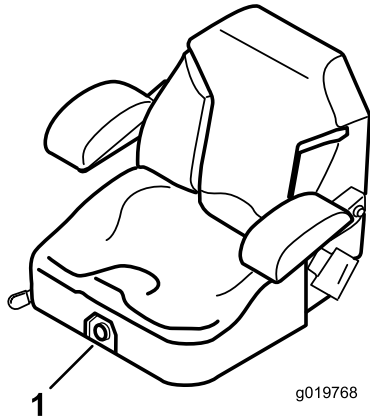

Figure 35

1. Seat suspension knob

Using the Drive Wheel Release Valves

⚠ WARNING

Hands may become entangled in the rotating drive components below the engine deck, which could result in serious injury.

Stop the engine, remove the key, and allow all moving parts to stop before accessing the drive wheel release valves.

⚠ WARNING

The engine and hydraulic drive units can become very hot. Touching a hot engine or hydraulic drive units can cause severe burns.

Allow the engine and hydraulic drive units to cool completely before accessing the drive wheel release valves.

The drive wheel release valves are located in the back of each hydraulic drive unit, under the seat.

Note: Make sure the release valves are in the fully horizontal position when operating the machine or severe damage to the hydraulic system can occur.

1. Disengage the PTO (blade-control switch) and turn the ignition key to off. Move the levers to neutral-locked position and apply parking brake. Remove the key.

2. Rotate the release valve levers vertically to push the machine. This allows hydraulic oil to by-pass the pump enabling the wheels to turn (Figure 36).
3. Disengage parking brake before pushing.

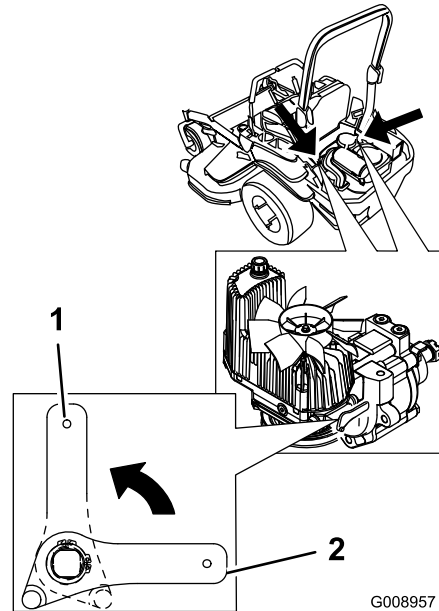

Figure 36

1. Vertical to push the machine
2. Horizontal to run the machine

4. Rotate the release valve levers horizontally to run the machine (Figure 36).

Using the Side Discharge

The mower has a hinged grass deflector that disperses clippings to the side and down toward the turf.

⚠ DANGER

Without a grass deflector, discharge cover, or complete grass catcher assembly mounted in place, you and others are exposed to blade contact and thrown debris. Contact with rotating mower blade(s) and thrown debris will cause injury or death.

- Never remove the grass deflector from the mower because the grass deflector routes material down toward the turf. If the grass deflector is ever damaged, replace it immediately.
- Never put your hands or feet under the mower.
- Never try to clear the discharge area or mower blades unless you move the power take off (blade-control switch (PTO) to the off position, rotate the ignition key to off and remove the key.
- Make sure the grass deflector is in the down position.

Transporting the Machine

Use a heavy-duty trailer or truck to transport the machine. Ensure that the trailer or truck has all necessary brakes, lighting, and marking as required by law. Please carefully read all the safety instructions. Knowing this information could help you, your family, pets, or bystanders avoid injury.

⚠ WARNING

Driving on the street or roadway without turn signals, lights, reflective markings, or a slow-moving vehicle emblem is dangerous and can lead to accidents causing personal injury.

Do not drive the machine on a public street or roadway.

To transport the machine:

1. If using a trailer, connect it to the towing vehicle and connect the safety chains.
2. If applicable, connect the trailer brakes.
3. Load the machine onto the trailer or truck.
4. Stop the engine, remove the key, set the brake, and close the fuel valve.
5. Use the metal tie-down loops on the machine to securely fasten the machine to the trailer or truck with straps, chains, cable, or ropes (Figure 37).

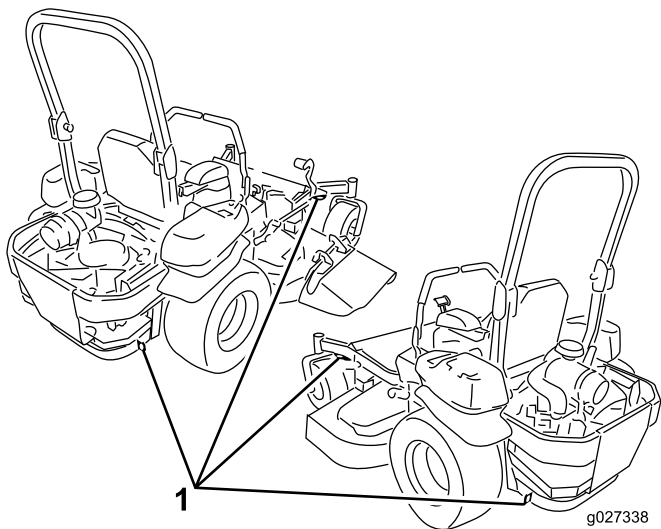

Figure 37

1. Tie-down loops

Loading the Machine

Use extreme caution when loading or unloading machines onto a trailer or a truck. Use a full-width ramp that is wider than the machine for this procedure. Back up ramps and drive forward down ramps (Figure 38).

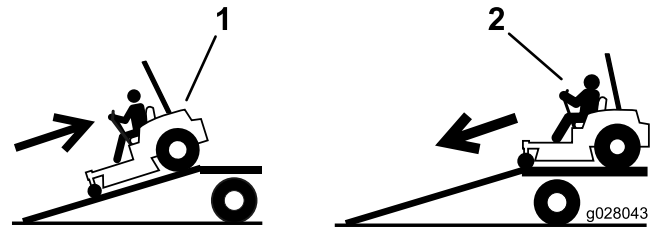

Figure 38

1. Back up ramps
2. Drive forward down ramps

Important: Do not use narrow individual ramps for each side of the machine.

Ensure the ramp is long enough so that the angle with the ground does not exceed 15 degrees (Figure 39). On flat ground, this requires a ramp to be at least four times (4X) as long as the height of the trailer or truck bed to the ground. A steeper angle may cause mower components to get caught as the unit moves from the ramp to the trailer or truck. Steeper angles may also cause the machine to tip or lose control. If loading on or near a slope, position the trailer or truck so that it is on the down side of the slope and the ramp extends up the slope. This will minimize the ramp angle.

⚠ WARNING

Loading a machine onto a trailer or truck increases the possibility of tip-over and could cause serious injury or death.

- Use extreme caution when operating a machine on a ramp.
- Ensure that the ROPS is in the up position and use the seat belt when loading or unloading the machine. Ensure that the ROPS will clear the top of an enclosed trailer.
- Use only a full-width ramp; do not use individual ramps for each side of the machine.
- Do not exceed a 15-degree angle between the ramp and the ground or between the ramp and the trailer or truck.
- Ensure the length of ramp is at least four times (4X) as long as the height of the trailer or truck bed to the ground. This will ensure that ramp angle does not exceed 15 degrees on flat ground.
- Back up ramps and drive forward down ramps.
- Avoid sudden acceleration or deceleration while driving the machine on a ramp as this could cause a loss of control or a tip-over situation.

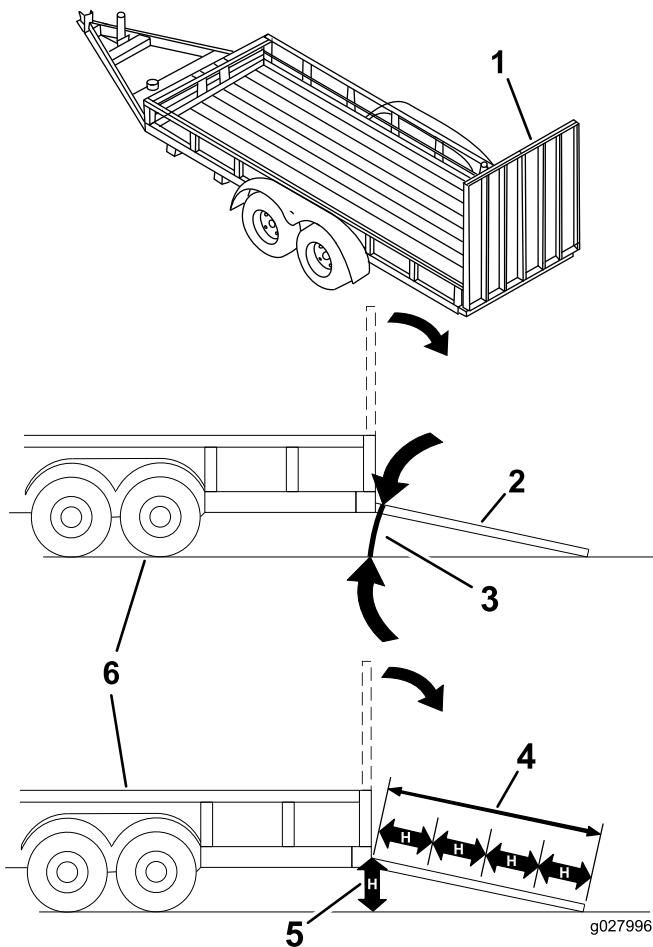

Figure 39

- | | |
|---|---|
| 1. Full-width ramp in stowed position | 4. Ramp is at least four times (4X) as long as the height of the trailer or truck bed to the ground |
| 2. Side view of full-width ramp in loading position | 5. H= height of the trailer or truck bed to the ground |
| 3. Not greater than 15 degrees | 6. Trailer |

Operating Tips

Fast Throttle Setting

For best mowing and maximum air circulation, operate the engine at the fast throttle position. Air is required to thoroughly cut grass clippings, so do not set the height-of-cut so low as to totally surround the mower by uncut grass. Always try to have one side of the mower free from uncut grass, which allows air to be drawn into the mower.

Cutting a Lawn for the First Time

Cut grass slightly longer than normal to ensure the cutting height of the mower does not scalp any uneven ground. However, the cutting height used in the past is generally the best one to use. When cutting grass longer than six inches tall, you may want to cut the lawn twice to ensure an acceptable quality of cut.

Cut 1/3 of the Grass Blade

It is best to cut only about 1/3 of the grass blade. Cutting more than that is not recommended unless grass is sparse, or it is late fall when grass grows more slowly.

Mowing Direction

Alternate mowing direction to keep the grass standing straight. This also helps disperse clippings which enhances decomposition and fertilization.

Mow at Correct Intervals

Normally, mow every four days. But remember, grass grows at different rates at different times. So to maintain the same cutting height, which is a good practice, mow more often in early spring. As the grass growth rate slows in mid summer, mow less frequently. If you cannot mow for an extended period, first mow at a high cutting height; then mow again two days later at a lower height setting.

Cutting Speed

To improve cut quality, use a slower ground speed in certain conditions.

Avoid Cutting Too Low

If the cutting width of the mower is wider than the mower you previously used, raise the cutting height to ensure that uneven turf is not cut too short.

Long Grass

If the grass is ever allowed to grow slightly longer than normal, or if it contains a high degree of moisture, raise the

cutting height higher than usual and cut the grass at this setting. Then cut the grass again using the lower, normal setting.

When Stopping

If you must stop the forward motion of the machine while mowing, a clump of grass clippings may drop onto your lawn. To avoid this, move onto a previously cut area with the blades engaged.

Keep the Underside of the Mower Clean

Clean clippings and dirt from the underside of the mower after each use. If grass and dirt build up inside the mower, cutting quality will eventually become unsatisfactory.

Blade Maintenance

Maintain a sharp blade throughout the cutting season because a sharp blade cuts cleanly without tearing or shredding the grass blades. Tearing and shredding turns grass brown at the edges, which slows growth and increases the chance of disease. Check the cutter blades daily for sharpness, and for any wear or damage. File down any nicks and sharpen the blades as necessary. If a blade is damaged or worn, replace it immediately with a genuine TORO replacement blade.

Maintenance

Recommended Maintenance Schedule(s)

Maintenance Service Interval	Maintenance Procedure
After the first 100 hours	<ul style="list-style-type: none"> • Check the wheel lug nut torque. • Check the wheel hub slotted-nut torque. • Check the parking brake adjustment.
After the first 250 hours	<ul style="list-style-type: none"> • Change the hydraulic filters and hydraulic oil when using any type of oil.
Before each use or daily	<ul style="list-style-type: none"> • Check the safety system. • Check the engine oil level. • Check the seat belt. • Check the rollover protection system (ROPS) knobs. • Clean the engine screen and the oil cooler. • Check and clean the hydraulic unit shrouds. • Check the mower blades. • Clean the mower deck.
Every 50 hours	<ul style="list-style-type: none"> • Grease the mower deck spindles and idler arm. • Check spark arrester (if equipped). • Check the tire pressure. • Inspect the belts for cracks and wear. • Check the hydraulic oil level.
Every 100 hours	<ul style="list-style-type: none"> • Lubricate the mower deck lift pivots. • Change the engine oil (more often in dirty or dusty conditions). • Check and clean engine cooling fins and shrouds.
Every 150 hours	<ul style="list-style-type: none"> • Inspect the primary filter and air-inlet screen.
Every 200 hours	<ul style="list-style-type: none"> • Change the engine oil filter. • Clean the engine oil cooler. • Check and gap the spark plug. • Replace the fuel filter (more often in dirty or dusty conditions).
Every 250 hours	<ul style="list-style-type: none"> • Change the hydraulic filters and hydraulic oil when using Mobil® 1 oil (more often in dirty or dusty conditions).
Every 300 hours	<ul style="list-style-type: none"> • Replace the primary air filter (more often in dusty or sandy conditions). • Check the inner air filter.
Every 500 hours	<ul style="list-style-type: none"> • Check the wheel lug nut torque. • Check the wheel hub slotted-nut torque. • Adjust the caster pivot bearing. • Check the parking brake adjustment. • Change the hydraulic filters and hydraulic oil when using Toro® HYPR-OIL™ 500 hydraulic oil (more often in dirty or dusty conditions).
Every 600 hours	<ul style="list-style-type: none"> • Replace the inner air filter.
Monthly	<ul style="list-style-type: none"> • Check the battery.
Yearly	<ul style="list-style-type: none"> • Grease the pump belt idler arm. • Grease the front caster pivots (more often in dirty or dusty conditions). • Repack the front caster wheel bearings (more often in dirty or dusty conditions). • Lubricate the caster wheel hubs.
Yearly or before storage	<ul style="list-style-type: none"> • Paint chipped surfaces. • Check all maintenance procedures listed above before storage.

Important: Refer to your engine operator's manual for additional maintenance procedures.

▲ CAUTION

If you leave the key in the ignition switch, someone could accidentally start the engine and seriously injure you or other bystanders.

Remove the key from the ignition before you do any maintenance.

Lubrication

Lubricating the Machine

Grease more frequently when operating conditions are extremely dusty or sandy.

Grease Type: No. 2 general-purpose lithium-based or molybdenum-based grease

1. Disengage the blade-control switch (PTO), move the motion-control levers to the neutral-locked position and set the parking brake.
2. Stop the engine, remove the key, and wait for all moving parts to stop before leaving the operating position.
3. Clean the grease fittings with a rag. Make sure to scrape any paint off the front of the fitting(s).
4. Connect a grease gun to the fitting. Pump grease into the fittings until grease begins to ooze out of the bearings.
5. Wipe up any excess grease.

Adding Light Oil or Spray Lubrication

Service Interval: Every 100 hours

Lubricate the deck lift pivots.

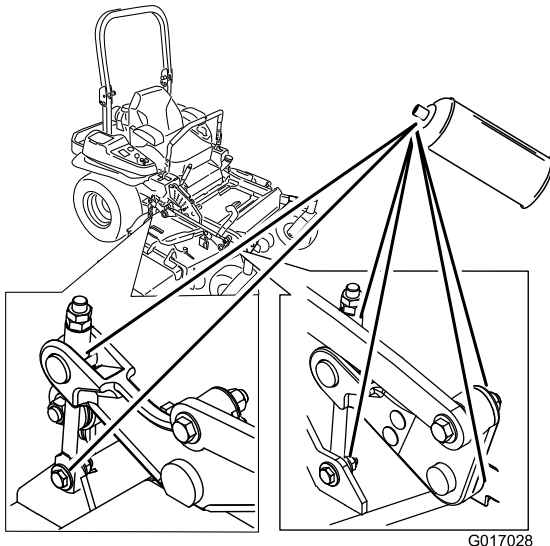

Figure 40

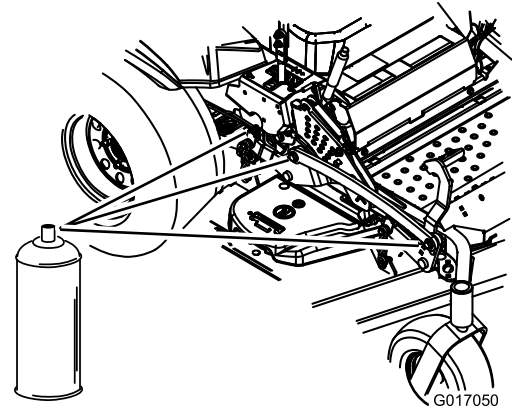

Figure 41

Greasing the Mower

Service Interval: Every 50 hours—Grease the mower deck spindles and idler arm.

Yearly—Grease the pump belt idler arm.

Yearly—Grease the front caster pivots (more often in dirty or dusty conditions).

Yearly—Repack the front caster wheel bearings (more often in dirty or dusty conditions).

Important: Make sure that the cutting unit spindles are full of grease weekly.

1. Disengage the blade-control switch (PTO), move the motion-control levers to the neutral-locked position, and set the parking brake.
2. Stop the engine, remove the key, and wait for all moving parts to stop before leaving the operating position.
3. Grease the mower deck idler pulley pivot until grease come out the bottom (Figure 42).
4. Grease the 3 spindle bearings until grease comes out the lower seals (Figure 42).

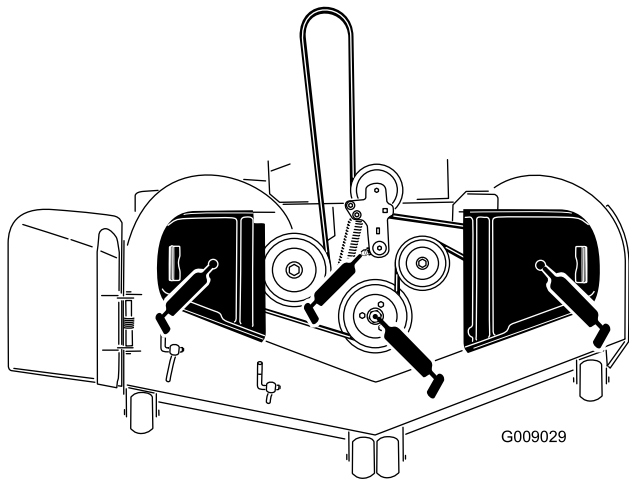

Figure 42

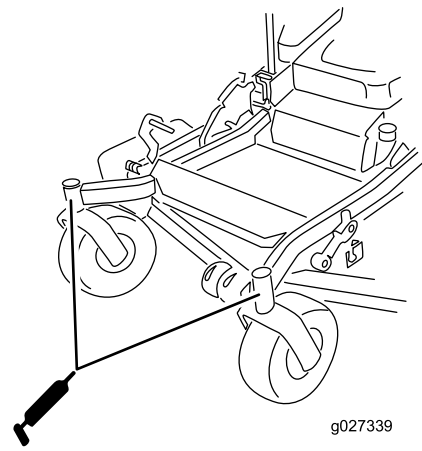

Figure 44

-
- Grease the drive belt idler arm (Figure 42).

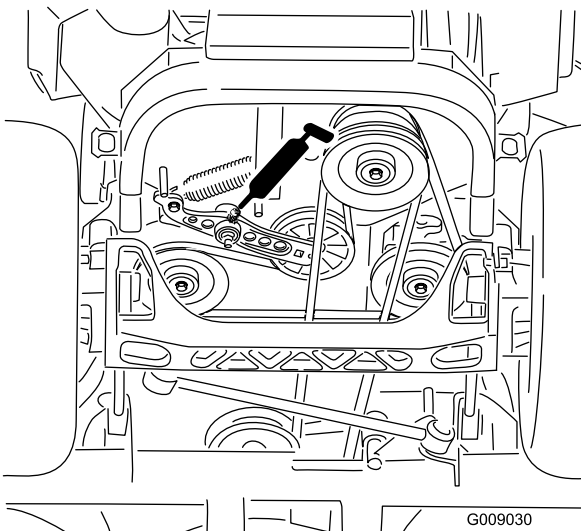

Figure 43

-
- Remove the dust cap and adjust the caster pivots.
Note: Keep the dust cap off until greasing is complete. Refer to [Adjusting the Caster Pivot Bearing](#) (page 46).
 - Remove the hex plug and thread a grease fitting into the hole.
 - Pump grease into the fitting until it oozes out around the top bearing.
 - Remove the grease fitting from the hole.
 - Install the hex plug and dust cap (Figure 44).

Lubricate the Caster Wheel Hubs

Service Interval: Yearly

1. Stop the engine, wait for all moving parts to stop, and remove the key. Engage the parking brake.

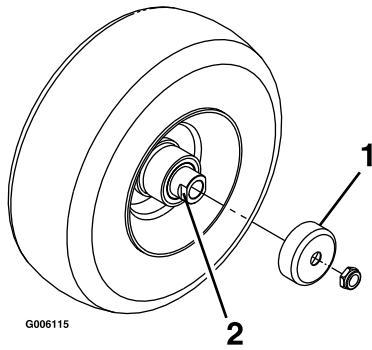

Figure 45

1. Seal guard
2. Spacer nut with wrench flats

2. Raise the front of the machine up and support it with jack stands.
3. Remove the caster wheel from the caster forks.
4. Remove the seal guards from the wheel hub.
5. Remove 1 of the spacer nuts from the axle assembly in the caster wheel.

Note: Note that thread locking adhesive has been applied to lock the spacer nuts to the axle. Remove the axle (with the other spacer nut still assembled to it) from the wheel assembly.

6. Pry out the seals, and inspect the bearings for wear or damage and replace if necessary.
7. Pack the bearings with a general-purpose grease.
8. Insert 1 bearing and 1 new seal into the wheel.

Note: The seals must be replaced.

9. If the axle assembly has had both spacer nuts removed (or broken loose), apply a thread locking adhesive to 1 spacer nut and thread it onto the axle with the wrench flats facing outward.

Note: Do not thread the spacer nut all of the way onto the end of the axle. Leave approximately 3 mm (1/8 inch) from the outer surface of the spacer nut to the end of the axle inside the nut.

10. Insert the assembled nut and axle into the wheel on the side of the wheel with the new seal and bearing.
11. With the open end of the wheel facing up, fill the area inside the wheel around the axle full of general-purpose grease.
12. Insert the second bearing and new seal into the wheel.

13. Apply a thread locking adhesive to the second spacer nut and thread it onto the axle with the wrench flats facing outward.
14. Torque the nut to 8-9 N-m (75-80 in-lb), loosen, then re-torque to 2-3 N-m (20-25 in-lb).
Note: Make sure that the axle does not extend beyond either nut.
15. Install the seal guards over the wheel hub and insert the wheel into the caster fork. Install the caster bolt and tighten the nut fully.

Important: To prevent seal and bearing damage, check the bearing adjustment often. Spin the caster tire. The tire should not spin freely (more than 1 or 2 revolutions) or have any side play. If the wheel spins freely, adjust the torque on the spacer nut until there is a slight amount of drag. Apply thread locking adhesive.

Engine Maintenance

⚠ WARNING

Contact with hot surfaces may cause personal injury.

Keep hands, feet, face, clothing, and other body parts away the muffler and other hot surfaces.

Servicing the Air Cleaner

Service Interval: Every 150 hours

Every 300 hours/Yearly (whichever comes first)—Replace the primary air filter (more often in dusty or sandy conditions).

Every 300 hours—Check the inner air filter.

Every 600 hours—Replace the inner air filter.

Note: Check the filters more frequently if the operating conditions are extremely dusty or sandy.

Removing the Filters

1. Disengage the PTO, move the motion-control levers to the neutral-locked position, and set the parking brake.
2. Stop the engine, remove the key, and wait for all moving parts to stop before leaving the operating position.
3. Release the latches on the air cleaner and pull the air-inlet cover off the air-cleaner body (Figure 46).
4. Clean the air-inlet screen and cover.
5. Install the air-inlet cover and secure it with the latches (Figure 46).

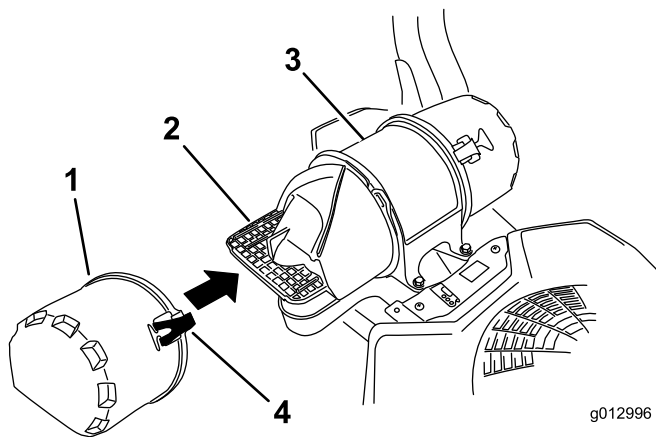

Figure 46

- | | |
|---------------------|---------------------|
| 1. Air-inlet cover | 3. Air-cleaner body |
| 2. Air-inlet screen | 4. Latch |

6. Release the latches on the air cleaner and pull the air-cleaner cover off the air-cleaner body (Figure 47).
7. Clean the inside of the air-cleaner cover with compressed air.

8. Gently slide the primary filter out of the air-cleaner body (Figure 47).

Note: Avoid knocking the filter into the side of the body.

9. Remove the inner filter only if you intend to replace it.

Important: Never attempt to clean the inner filter. If the safety filter is dirty, then the primary filter is damaged; replace both filters.

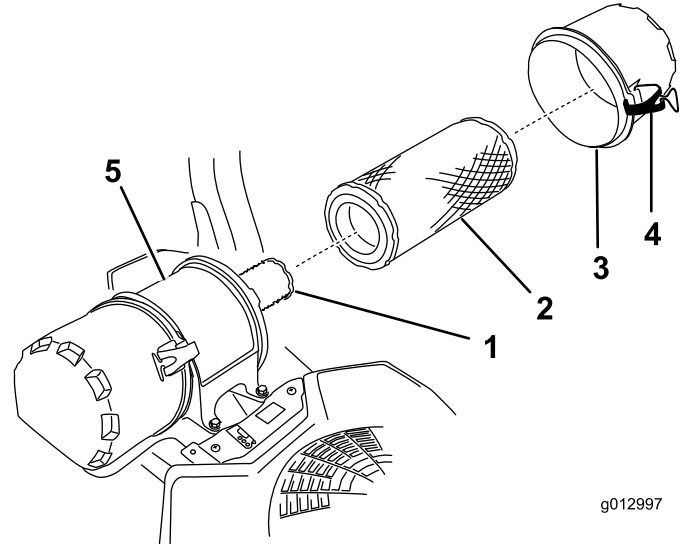

Figure 47

- | | |
|----------------------|---------------------|
| 1. Inner filter | 4. Latch |
| 2. Primary filter | 5. Air-cleaner body |
| 3. Air-cleaner cover | |

10. Inspect the primary filter for damage by looking into the filter while shining a bright light on the outside of the filter.

Note: Any holes in the filter will appear as bright spots. If the filter is damaged, discard it.

Servicing the Primary Filter

- If the primary filter is dirty, bent, or damaged, replace it.
- Do not clean the primary filter.

Servicing the Safety Filter

Replace the safety filter, never clean it.

Important: Never attempt to clean the safety filter. If the safety filter is dirty, then the primary filter is damaged. Replace both filters.

Installing the Filters

Important: To prevent engine damage, always operate the engine with both air filters and cover installed.

1. If installing new filters, check each filter for shipping damage. Do not use a damaged filter.

- If the inner filter is being replaced, carefully slide it into the filter body (Figure 47).
- Carefully slide the primary filter over the inner filter (Figure 47).

Note: Ensure that the primary filter is fully seated by pushing on its outer rim while installing it.

Important: Do not press on the soft inside area of the filter.

- Install the air cleaner cover and secure the latches (Figure 47).

Servicing the Engine Oil

Oil Type: Detergent oil (API service class SL, SM, SN, or higher)

Oil Capacity: with a filter change, 1.7 L (1.8 US qt); with no filter change, 1.4 L (1.5 US qt)

Viscosity: See the table below.

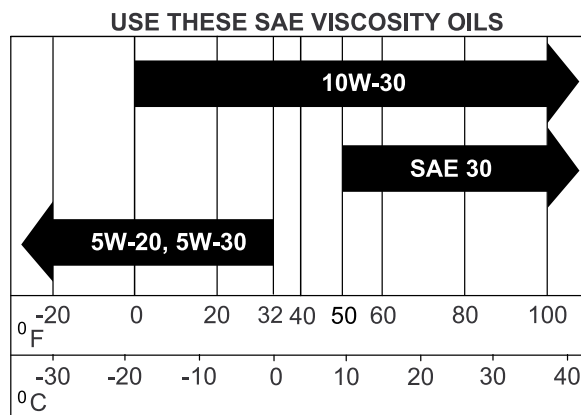

Figure 48

Note: Use of synthetic oil having 5W-20 or 5W-30 rating is acceptable, up to 4 degrees C (40 degrees F).

Note: Synthetic oils will provide better starting in extreme cold below -23 degrees C (-10 degrees F).

Checking the Engine-Oil Level

Service Interval: Before each use or daily

Note: Check the oil when the engine is cold.

⚠ WARNING

Contact with hot surfaces may cause personal injury.

Keep hands, feet, face, clothing and other body parts away from the muffler and other hot surfaces.

Important: Do not overfill the crankcase with oil because damage to the engine may result. Do not run engine with oil below the low mark because the engine may be damaged.

- Disengage the PTO, move the motion-control levers to the neutral-locked position and set the parking brake.
- Stop the engine, remove the key, and wait for all moving parts to stop before leaving the operating position (Figure 49).

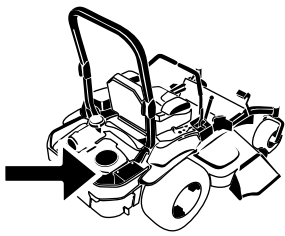

G008804

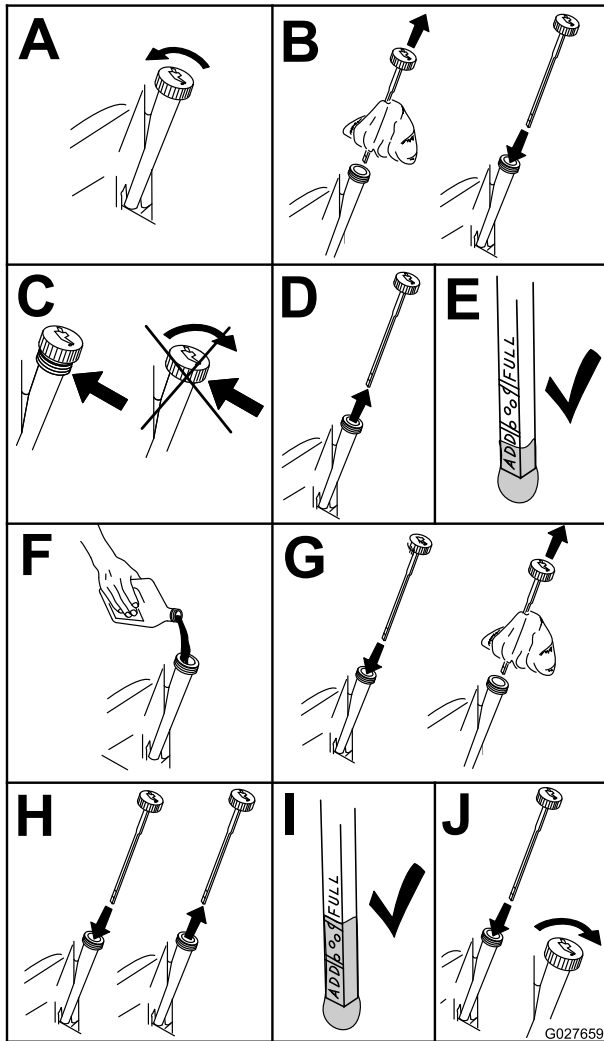

Figure 49

Changing the Engine Oil

Service Interval: Every 100 hours (more often in dirty or dusty conditions).

Note: Dispose of the used oil at a recycling center.

1. Park the machine so that the rear is slightly lower than the front to ensure that the oil drains completely.
2. Disengage the PTO, move the motion-control levers to the neutral-locked position, and set the parking brake.
3. Stop the engine, remove the key, and wait for all moving parts to stop before leaving the operating position (Figure 50).

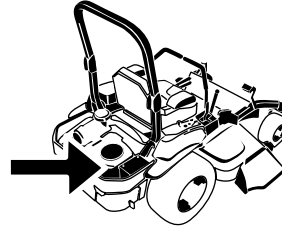

G008804

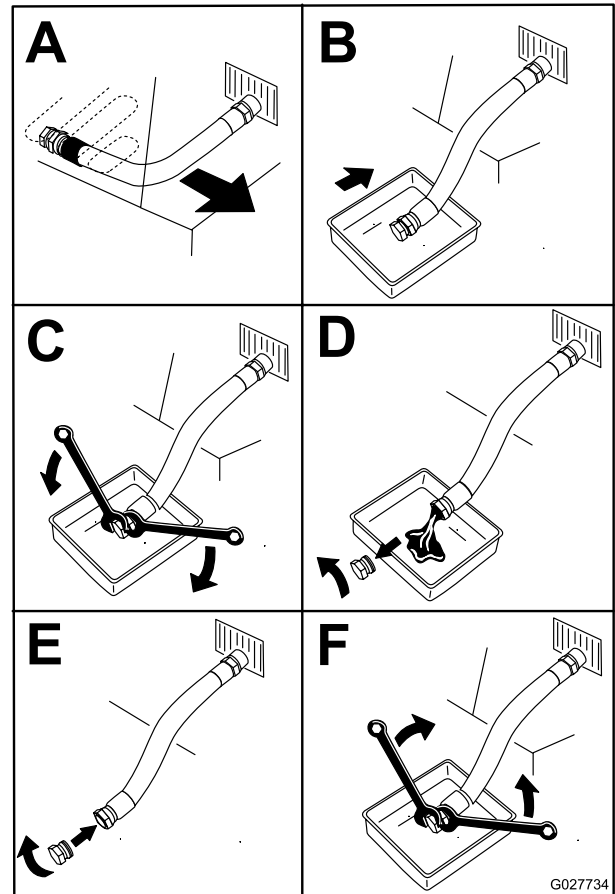

Figure 50

- Slowly pour approximately 80% of the specified oil into the filler tube and slowly add the additional oil to bring it to the **Full** mark (Figure 51).

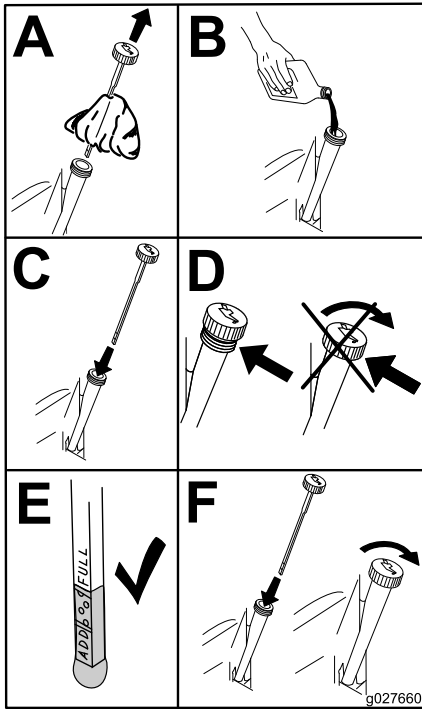

Figure 51

- Start the engine and drive to a flat area. Check the oil level again.

Changing the Engine-Oil Filter

Service Interval: Every 200 hours

Note: Change the engine oil filter more frequently when operating conditions are extremely dusty or sandy.

- Drain the oil from the engine; refer to [Changing the Engine Oil](#) (page 36).
- Change the engine oil filter (Figure 52).

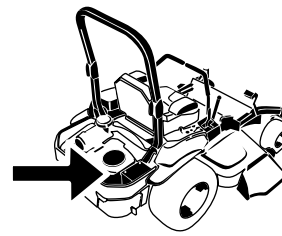

G008804

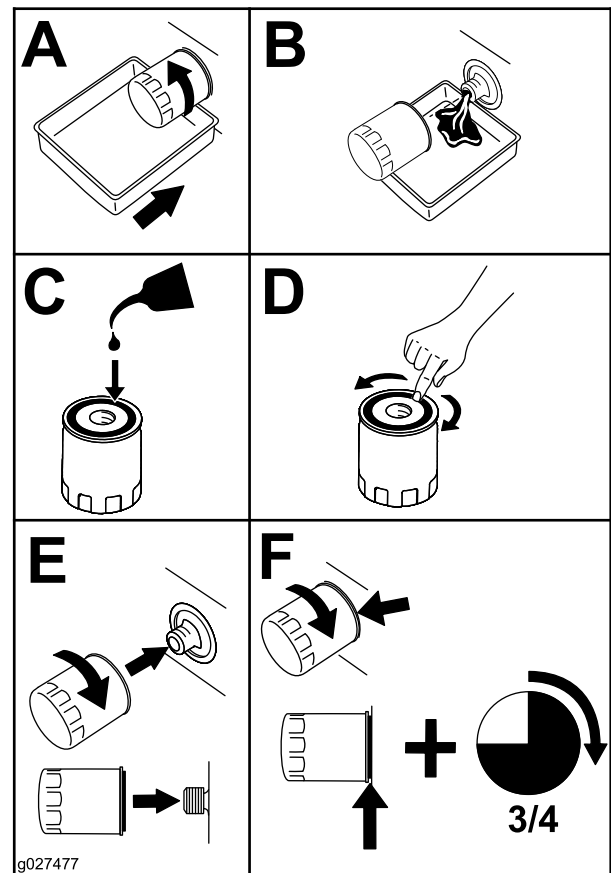

Figure 52

Note: Ensure the oil filter gasket touches the engine and then an extra 3/4 turn is completed.

- Fill the crankcase with the proper type of new oil; refer to [Changing the Engine Oil](#) (page 36).

Servicing the Engine-Oil Cooler

Service Interval: Every 200 hours

- Keep the oil cooler free of debris. by cleaning the fins with a brush.
- Remove the bolts holding the oil cooler to the engine housing .
- Clean the inside of the oil cooler with a brush.
- Install the oil cooler to the engine housing.

Servicing the Spark Plugs

Service Interval: Every 200 hours—Check and gap the spark plug.

Make sure that the air gap between the center and side electrodes is correct before installing the spark plugs. Use a spark-plug wrench for removing and installing the spark plugs and a gapping tool/feeler gauge to check and adjust the air gap. Install new spark plugs if necessary.

Type : Champion® XC12YC, Champion® Platinum 3071 or equivalent

Air Gap: 0.76 mm (0.030 inch)

Removing the Spark Plugs

1. Stop the engine, remove the key, and wait for all moving parts to stop before leaving the operating position.
2. Disengage the PTO, move the motion-control levers to the neutral-locked position and set the parking brake.
3. Remove the left-hand hydraulic unit shroud in the order listed with [Figure 54](#).

Note: This gives you access to the front spark plug.

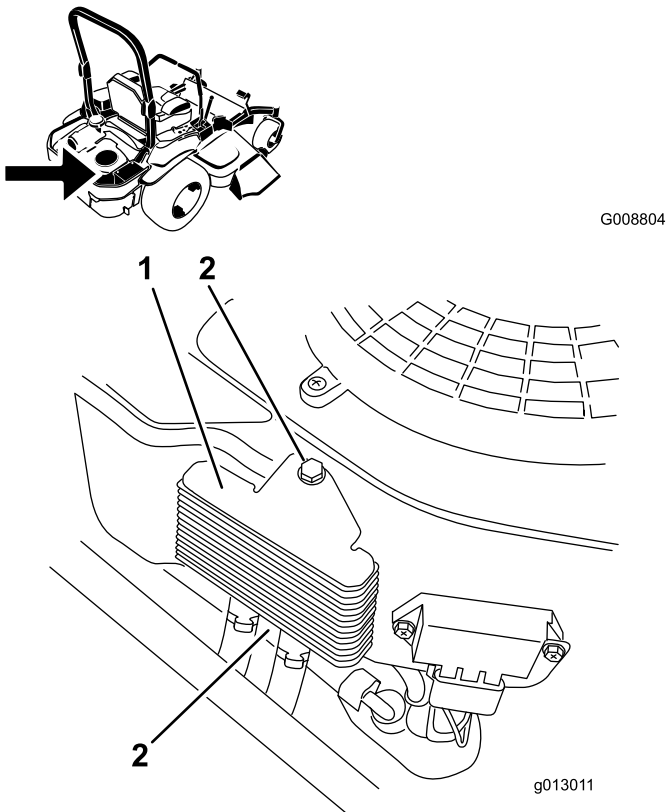

Figure 53

1. Engine oil cooler

2. Bolts

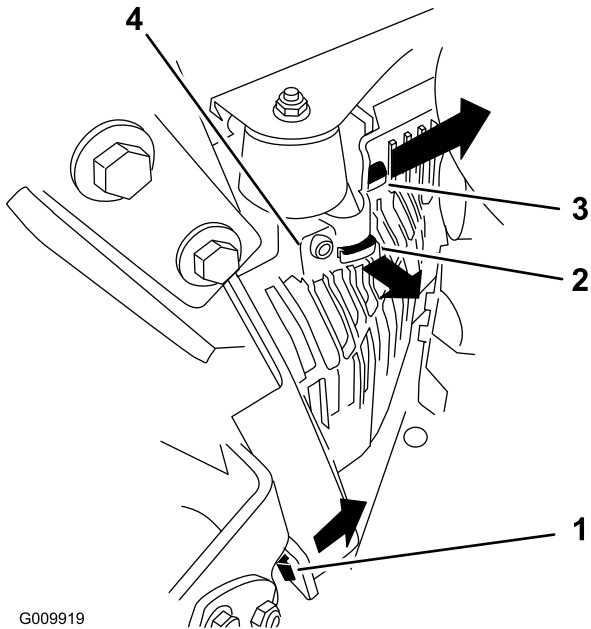
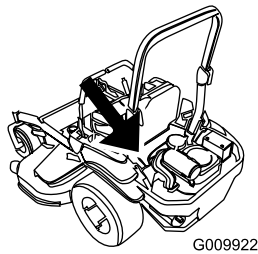

Figure 54

1. Pull this tab out to the side in the direction of the arrow.
2. Pull the shroud off of this frame tab in the direction of the arrow.
3. Pull the shroud off of this frame tab in the direction of the arrow.
4. Shroud

4. Remove the spark plugs.

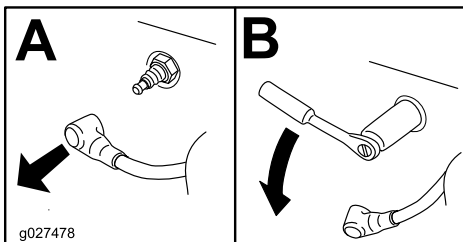
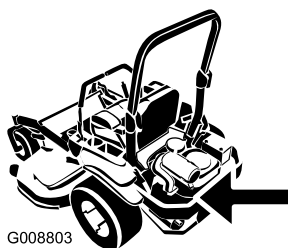

Figure 55

5. Install the lefthand hydraulic unit shroud (Figure 54).

Checking the Spark Plugs

Important: Replace the spark plugs when they have: a black coating, worn electrodes, an oily film, cracks or reuse is questionable.

If you see light brown or gray on the insulator, the engine is operating properly. A black coating on the insulator usually means that the air cleaner is dirty.

Set the gap to 0.76 mm (0.030 inch).

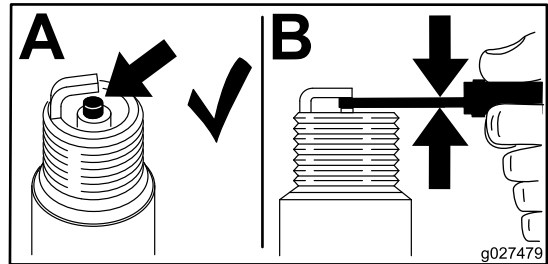

Figure 56

Installing the Spark Plugs

Tighten the spark plugs to 24.4 to 29.8 N-m (18 to 22 ft.-lb).

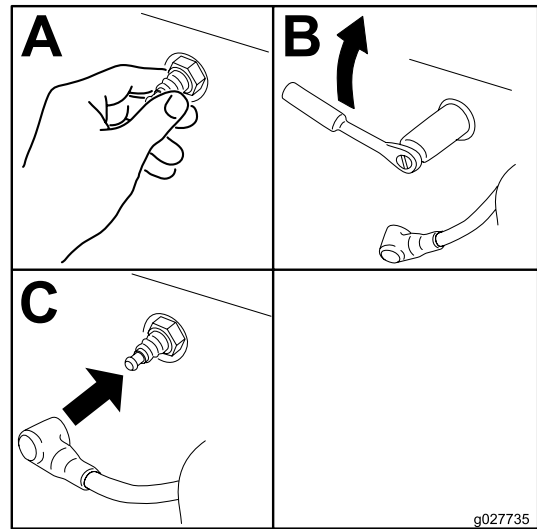

Figure 57

Check Spark Arrester (if equipped)

Service Interval: Every 50 hours

⚠ WARNING

Hot exhaust system components may ignite gasoline vapors even after the engine is stopped. Hot particles exhausted during engine operation may ignite flammable materials. Fire may result in personal injury or property damage.

Do not fuel or run the engine unless spark arrester is installed.

1. Stop engine, wait for all moving parts to stop, and remove key. Engage parking brake.
2. Wait for muffler to cool.
3. If any breaks in the screen or welds are observed, replace the arrester.
4. If plugging of the screen is observed, remove the arrester and shake loose particles out of the arrester and clean screen with a wire brush (soak in solvent if necessary). Reinstall arrester on exhaust outlet.

Fuel System Maintenance

⚠ WARNING

Fuel system components are under high pressure. The use of improper components can result in system failure, gasoline leakage, and possible explosion.

Use only approved fuel lines and fuel filters.

Servicing the Electronic Fuel Injection System

This machine contains an electronic fuel injection system. It controls the fuel flow under different operating conditions.

The electronic control unit (ECU) continuously monitors the operation of the EFI system.

If a problem or fault within the system is detected, the malfunction indicator light (MIL) is illuminated. The MIL is the red light located in the right console panel.

Once the MIL illuminates, initial trouble shooting checks should be made. Refer to the MIL section under Troubleshooting.

If these checks do not correct the problem, further diagnosis and servicing by an Authorized Service Dealer is necessary.

Replacing the Low-Pressure Fuel Filter

Service Interval: Every 200 hours/Yearly (whichever comes first) (more often in dirty or dusty conditions).

The fuel filter is located near the engine on the front or rear side of the engine.

1. Disengage the PTO, move the motion-control levers to the neutral-locked position, and set the parking brake.
2. Stop the engine, remove the key, and wait for all moving parts to stop before leaving the operating position.
3. Allow the machine to cool down.
4. Close the fuel-shutoff valve under the seat ([Figure 58](#)).

Electrical System Maintenance

Servicing the Battery

Service Interval: Monthly

WARNING

CALIFORNIA

Proposition 65 Warning

Battery posts, terminals, and related accessories contain lead and lead compounds, chemicals known to the State of California to cause cancer and reproductive harm.

Wash hands after handling.

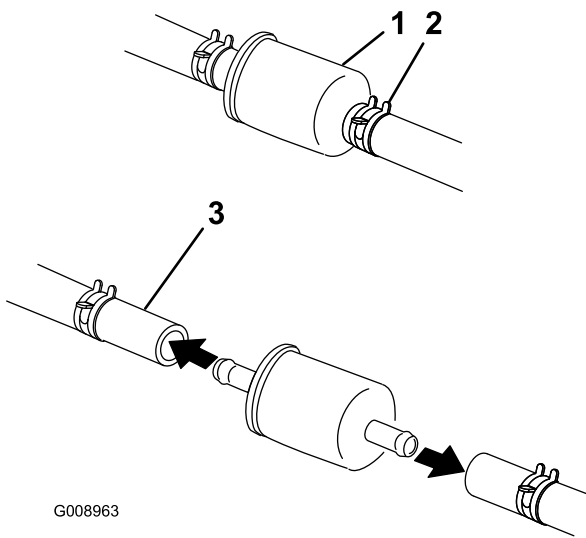

G008963

Figure 58

1. Fuel filter
2. Hose clamp
3. Fuel line

5. Squeeze the ends of the hose clamps together and slide them away from the filter (Figure 58).
6. Remove the filter from the fuel lines.
7. Install a new filter and move the hose clamps close to the filter (Figure 58).
8. Open the fuel-shutoff valve.

Note: It is important to install the fuel line hoses and secure them with plastic ties the same as they were originally installed at the factory, to keep the fuel line away from components that could cause fuel line damage.

Servicing the High-Pressure Fuel Filter

Do not attempt to service the high-pressure fuel filter. The high-pressure filter is integrated within the fuel pump module. The fuel filter and other components inside the fuel pump module are not serviceable. **Do not** attempt to open the fuel pump module.

Ensure that an Authorized Service Dealer replaces the fuel pump module with the high-pressure fuel filter.

Servicing the Fuel Tank

Do not attempt to drain the fuel tank. Ensure that an Authorized Service Dealer drains the fuel tank.

⚠ DANGER

Battery electrolyte contains sulfuric acid which is a deadly poison and causes severe burns.

Do not drink electrolyte and avoid contact with skin, eyes or clothing. Wear safety glasses to shield your eyes and rubber gloves to protect your hands.

Removing the Battery

⚠ WARNING

Battery terminals or metal tools could short against metal machine components causing sparks. Sparks can cause the battery gases to explode, resulting in personal injury.

- When removing or installing the battery, do not allow the battery terminals to touch any metal parts of the machine.
- Do not allow metal tools to short between the battery terminals and metal parts of the machine.

⚠ WARNING

Incorrect battery cable routing could damage the machine and cables causing sparks. Sparks can cause the battery gases to explode, resulting in personal injury.

- Always disconnect the negative (black) battery cable before disconnecting the positive (red) cable.
- Always connect the positive (red) battery cable before reconnecting the negative (black) cable.

1. Disengage the blade-control switch (PTO), move the motion-control levers to the neutral-locked position and set the parking brake.
2. Stop the engine, remove the key, and wait for all moving parts to stop before leaving the operating position.
3. First disconnect the negative battery cable (black) from the negative (-)(black) battery terminal (Figure 59).
4. Slide the red terminal boot off the positive (red) battery terminal and remove the positive (+)(red) battery cable (Figure 59).
5. Remove the wing nut securing the battery clamp (Figure 59).
6. Remove the clamp (Figure 59).
7. Remove the battery.

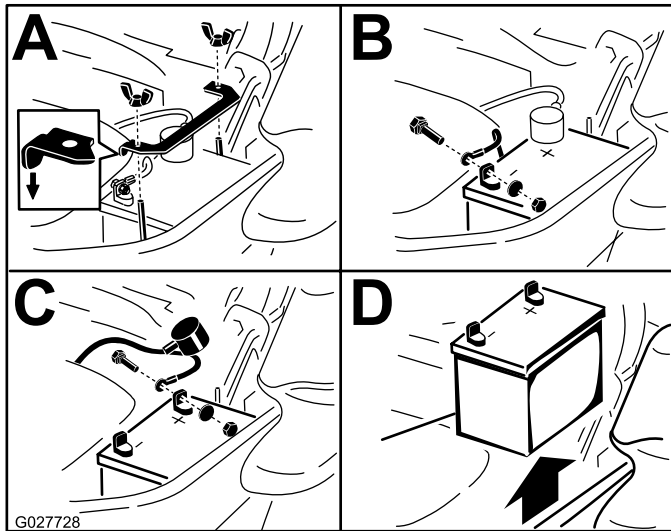

Figure 59

1. Remove the wing nut and clamp
2. Remove the negative battery cable before the positive
3. Remove the positive battery cable
4. Remove battery

Installing the Battery

1. Position battery in the tray with the terminal posts opposite from the hydraulic tank (Figure 59).
2. First, install the positive (red) battery cable to positive (+) battery terminal.
3. Then install the negative (black) battery cable and ground wire to the negative (-) battery terminal.
4. Secure the cables with 2 bolts, 2 washers, and 2 locknuts (Figure 59).
5. Slide the red terminal boot onto the positive (red) battery post.
6. Install the clamp and secure it with the wing nut (Figure 59).

Charging the Battery

⚠ WARNING

Charging the battery produces gases that can explode.

Never smoke near the battery and keep sparks and flames away from battery.

Important: Always keep the battery fully charged (1.265 specific gravity). This is especially important to prevent battery damage when the temperature is below 0°C (32°F).

1. Charge battery for 10 to 15 minutes at 25 to 30 amps or 30 minutes at 10 amps.
2. When the battery is fully charged, unplug the charger from the electrical outlet; then disconnect the charger leads from the battery posts (Figure 60).
3. Install the battery in the machine and connect the battery cables, refer to Installing the Battery.

Note: Do not run the machine with the battery disconnected; electrical damage may occur.

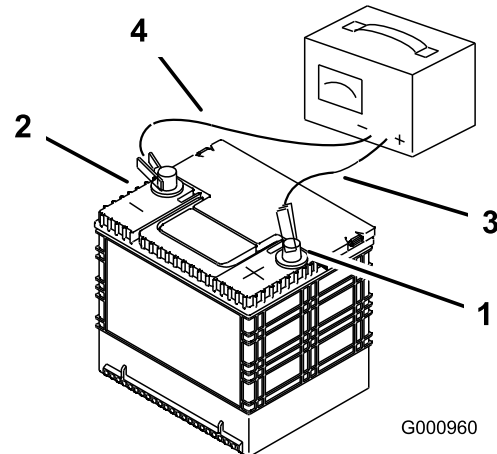

Figure 60

1. Positive battery post
2. Negative battery post
3. Red (+) charger lead
4. Black (-) charger lead

Servicing the Fuses

The electrical system is protected by fuses. It requires no maintenance; however, if a fuse blows check the component/circuit for a malfunction or short.

1. The fuses are located on right hand console next to the seat (Figure 61).
2. To replace the fuses, pull out on the fuse to remove it.
3. Install a new fuse (Figure 61).

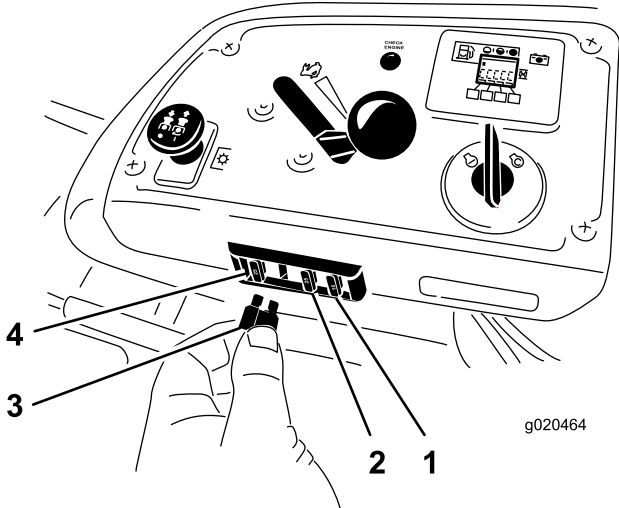

Figure 61

- | | |
|------------------------------|---------------|
| 1. Optional accessory—15 amp | 4. Main—25amp |
| 2. Charge—25amp | 5. Console |
| 3. PTO—10amp | |

2. Make sure that the booster battery is a good and fully charged lead-acid battery at 12.6 volts or greater. Use properly sized jumper cables with short lengths to reduce voltage drop between systems. Make sure that the cables are color coded or labeled for the correct polarity.

CAUTION

Connecting the jumper cables incorrectly (wrong polarity) can immediately damage the EFI system.

Be certain of battery terminal polarity and jumper cable polarity when hooking up batteries.

WARNING

Batteries contain acid and produce explosive gases.

- Shield the eyes and face from the batteries at all times.
- Do not lean over the batteries.

Note: Be sure the vent caps are tight and level. Place a damp cloth, if available, over any vent caps on both batteries. Be sure the vehicles do not touch and that both electrical systems are off and at the same rated system voltage. These instructions are for negative ground systems only.

Jump-Starting the Machine

1. Check and clean corrosion from the battery terminals before jump-starting. Ensure that the connections are tight.

CAUTION

Corrosion or loose connections can cause unwanted electrical voltage spikes at any time during the jump-starting procedure.

Do not attempt to jump-start with loose or corroded battery terminals, or damage to the engine or EFI may occur.

DANGER

Jump-starting a weak battery that is cracked or frozen, or has a low electrolyte level or an open/shorted battery cell can cause an explosion resulting in serious personal injury.

Do not jump-start a weak battery if these conditions exist.

3. Connect the positive (+) cable to the positive (+) terminal of the discharged battery that is wired to the starter or solenoid as shown in Figure 62.

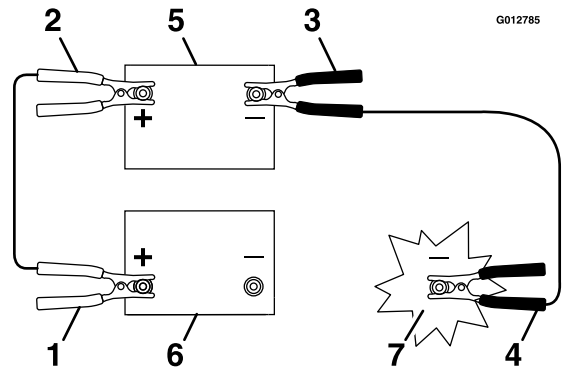

Figure 62

- | | |
|--|-----------------------|
| 1. Positive (+) cable on discharged battery | 5. Booster battery |
| 2. Positive (+) cable on booster battery | 6. Discharged battery |
| 3. Negative (-) cable on the booster battery | 7. Engine block |
| 4. Negative (-) cable on the engine block | |

4. Connect the other end of the positive cable to the positive terminal of the booster battery.
5. Connect the black negative (-) cable to the other terminal (negative) of the booster battery.
6. **Make the final connection on the engine block of the stalled vehicle (not to the negative battery post) away from the battery and stand back (Figure 64).**

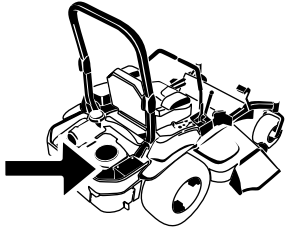

Figure 63

G008804

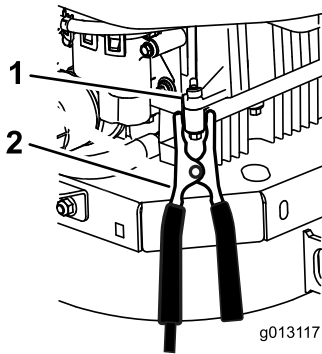

Figure 64

g013117

1. Engine block
2. Negative (-) cable

7. Start the vehicle and remove the cables in the reverse order of connection (the engine block (black) connection is the first to disconnect).

Drive System Maintenance

Checking the Seat Belt

Service Interval: Before each use or daily

Visually inspect seat belt for wear, cuts, and proper operation of retractor and buckle. Replace before operating if damaged.

Checking the Knobs on the Rollover Protection System (ROPS)

Service Interval: Before each use or daily

⚠ WARNING

To avoid injury or death from rollover: keep the roll bar in the fully raised locked position and use the seat belt.

Ensure that the rear part of the seat is secured with the seat latch.

Check that both the mounting hardware and the knobs are in good working condition. Make sure the knobs are fully engaged with the ROPS in the fully raised position. The upper hoop of the roll bar may need to be pushed forward or pulled rearward to get both knobs fully engaged.

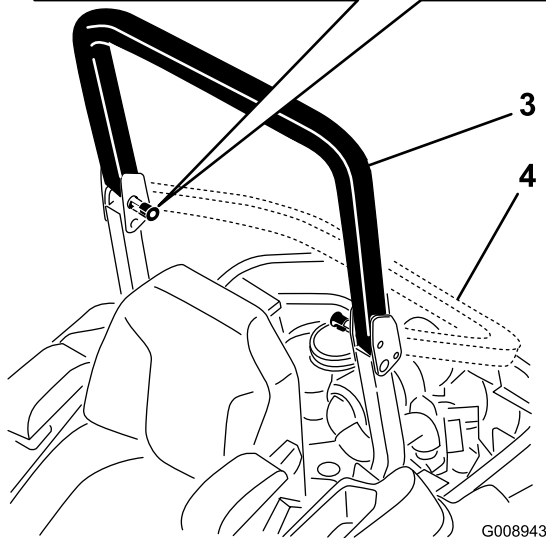
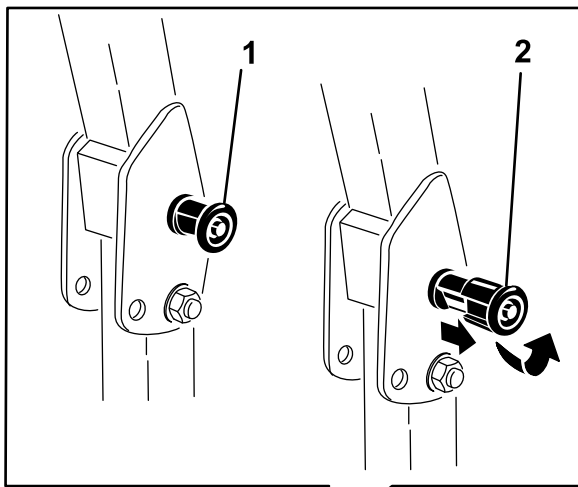

Figure 65

- | | |
|---|-------------------------------------|
| 1. ROPS knob (locked position) | 3. Roll bar in the upright position |
| 2. Pull ROPS knob out and rotate 90 degrees to change roll bar position | 4. Roll bar in the folded position |

Adjusting the Tracking

1. Disengage the blade-control switch (PTO).
2. Drive to an open flat area, move the motion-control levers to the neutral-locked position.
3. Move the throttle midway between fast and slow.
4. Move both motion-control levers all the way forward until they both hit the stops in the T-slot.
5. Check which way the machine tracks.
6. If it tracks to the right, loosen the bolts and adjust the left stop plate rearward on the left T-slot until the machine tracks straight (Figure 66).
7. If it tracks to the left, loosen the bolts and adjust the right stop plate rearward on the right T-slot until the machine tracks straight (Figure 66).
8. Tighten the stop plate (Figure 66).

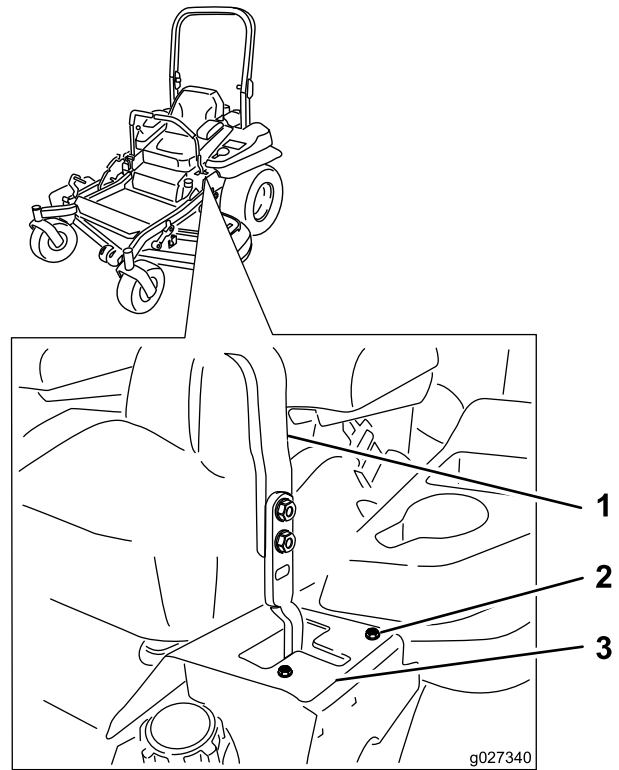

Figure 66
Left control lever shown

- | | |
|------------------|---------------|
| 1. Control lever | 3. Stop plate |
| 2. Bolt | |

Checking the Tire Pressure

Service Interval: Every 50 hours/Monthly (whichever comes first)

Maintain the air pressure in the rear tires at 90 kPa (13 psi). Uneven tire pressure can cause uneven cut. Check the tires when they are cold, to get the most accurate pressure reading.

Note: The front tires are semi-pneumatic tires and do not require air pressure maintenance.

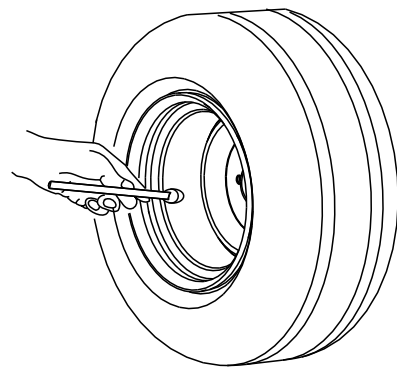

G001055

Figure 67

Checking the Wheel Lug Nuts

Check and torque the wheel lug nuts to 122 to 129 N-m (90 to 95 ft-lb).

Checking the Wheel Hub Slotted Nut

Service Interval: After the first 100 hours

Every 500 hours

Check and ensure that the torque of the slotted nut is 286 to 352 N-m (211 to 260 ft-lb).

Note: Do not use anti-seize on wheel hub.

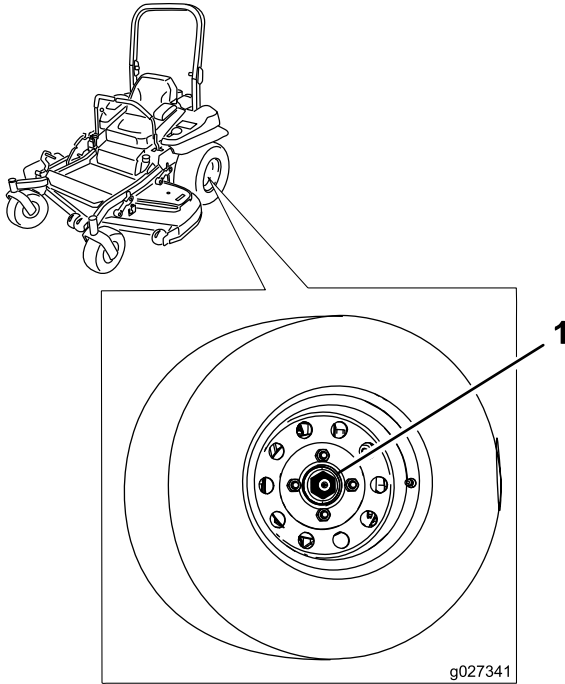

Figure 68

1. Slotted nut

Adjusting the Caster Pivot Bearing

Service Interval: Every 500 hours/Yearly (whichever comes first)

1. Disengage the blade-control switch (PTO), move the motion-control levers to the neutral-locked position and set the parking brake.
2. Stop the engine, remove the key, and wait for all moving parts to stop before leaving the operating position.
3. Remove the dust cap from the caster and tighten the locknut (Figure 69).
4. Tighten the locknut until the spring washers are flat and then back off a 1/4 turn to properly set the pre-load on the bearings (Figure 69).

Important: Make sure that the spring washers are installed correctly as shown in Figure 69.

5. Install the dust cap (Figure 69).

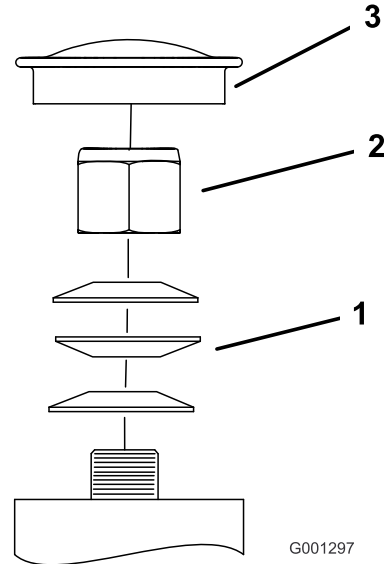

Figure 69

1. Spring washers
2. Locknut
3. Dust cap

Using the Clutch Shim

Some later model year units have been built with clutches that contain a brake shim. When the clutch brake has worn to the point where the clutch no longer engages consistently, the shim can be removed to extend the clutch life.

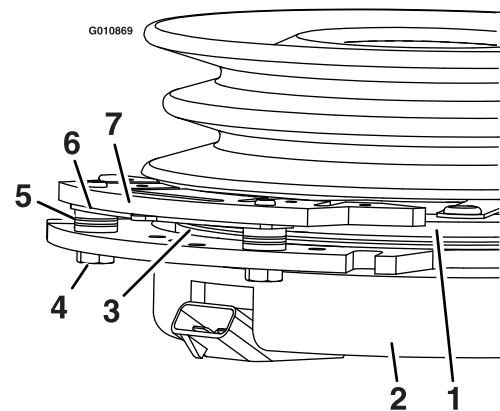

Figure 70

1. Armature
2. Field shell
3. Rotor
4. Brake mounting bolt
5. Brake spacer
6. Re-gap shim
7. Brake pole

Removing the Clutch Shim

1. Stop the engine, wait for all moving parts to stop, and remove the key. Engage the parking brake. Allow the machine to cool completely before starting these instructions.
2. Using an air compressor, blow out any debris from under the brake pole and around the brake spacers.

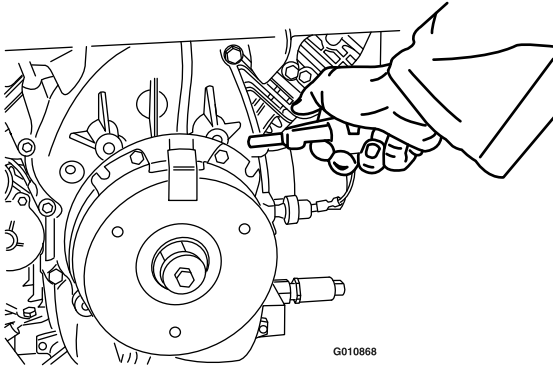

Figure 71

3. Check the condition of the wire harness leads, connectors, and terminals. Clean or repair as necessary.
4. Verify that 12V is present at the clutch connector when the PTO switch is engaged.
5. Measure the gap between the rotor and the armature. If the gap is greater than 1 mm (0.04 inch), proceed with the following steps:
 - A. Loosen both brake mounting bolts one-half to one full turn as shown below.

Note: Do not remove the brake pole from the field shell/armature. The brake pole has worn to match the armature and needs to continue to match after the shim is removed to ensure proper brake torque.

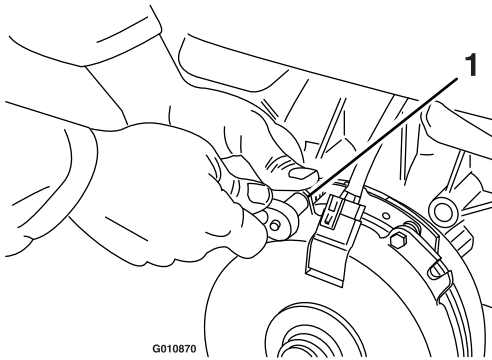

Figure 72

1. Brake mounting bolt

- B. Using needle-nose pliers, or by hand, take hold of the tab and remove the shim.

Note: Do not discard the shim until proper clutch function has been confirmed.

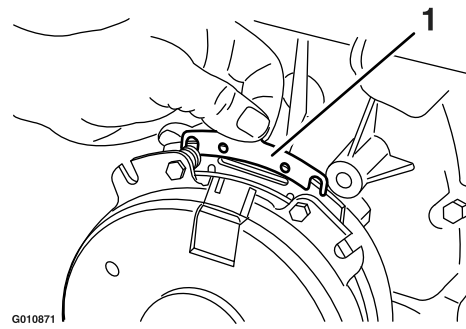

Figure 73

1. Shim

- C. Using a pneumatic line, blow out any debris from under the brake pole and around the brake spacers.
- D. Re-torque each bolt (M6 x 1) to 13 N-m (10 ft-lb) +/- 0.7 N-m (0.5 ft-lb).
- E. Using a 0.010 inch thick feeler gauge, verify that a gap is present between the rotor and armature face on both sides of the brake pole as shown. (Due to the way the rotor and armature faces wear (peaks and valleys) it is sometimes difficult to measure the true gap.)

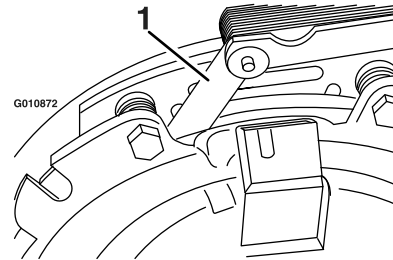

Figure 74

1. Feeler gauge

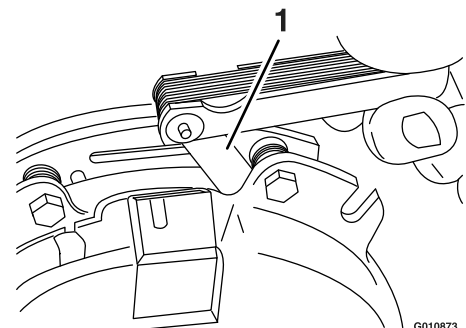

Figure 75

1. Feeler gauge

- If the gap is less than 0.010 inch, then reinstall the shim and reference the **Troubleshooting** section.
- If the gap is sufficient, proceed to the safety check in step F.

F. Perform the following safety check:

- i. Sit on the seat and start the engine.
- ii. Make sure that the blades do not engage with the PTO switched off and the clutch disengaged.

If the clutch does not disengage, install the shim and reference the **Troubleshooting** section.

- iii. Engage and disengage the PTO switch 10 consecutive times to ensure that the clutch is functioning properly. If the clutch does not engage properly, reference the **Troubleshooting** section.

Cooling System Maintenance

Cleaning the Engine Screen and Engine-Oil Cooler

Service Interval: Before each use or daily

Remove any buildup of grass, dirt, or other debris from the oil cooler (Figure 76).

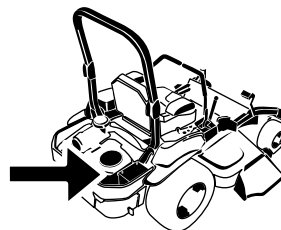

G008804

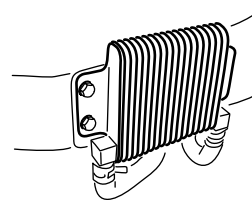

G009191

Figure 76

Before each use remove any buildup of grass, dirt, or other debris from the engine screen. This will help ensure adequate cooling and correct engine speed and will reduce the possibility of overheating and mechanical damage to the engine (Figure 77).

Cleaning the Engine Cooling Fins and Shrouds

Service Interval: Every 100 hours/Yearly (whichever comes first)

1. Disengage the PTO and set the parking brake.
2. Stop the engine, remove the key, and wait for all moving parts to stop before leaving the operating position.
3. Remove the air intake screen, recoil starter, and fan housing (Figure 77).
4. Clean the debris and grass from the engine parts.
5. Install air intake screen, recoil starter, and fan housing (Figure 77).

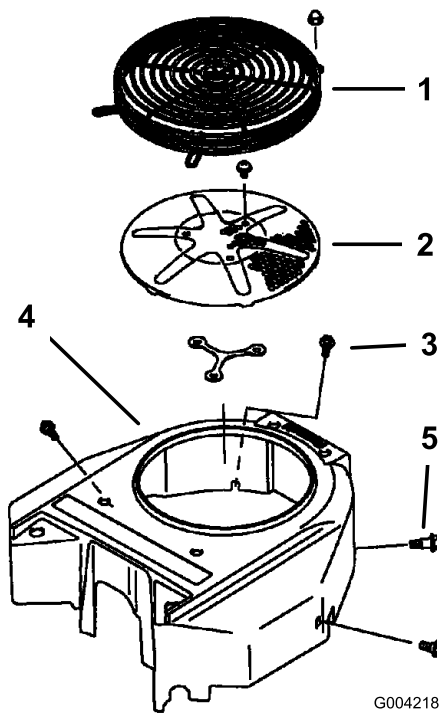
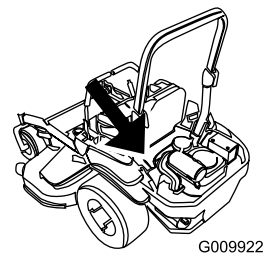
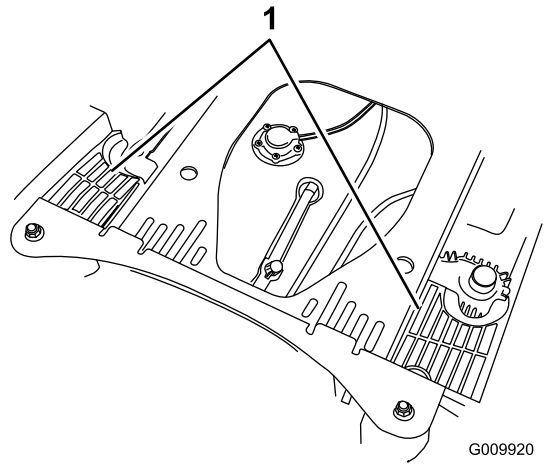

Figure 77

- | | |
|-----------------------------|----------------|
| 1. Engine guard | 4. Fan housing |
| 2. Engine air intake screen | 5. Screw |
| 3. Bolt | |



G009922



G009920

Figure 78

1. Hydraulic unit shrouds

Check and Clean the Hydraulic-Unit Shrouds

Service Interval: Before each use or daily

1. Disengage the PTO and set the parking brake.
2. Stop the engine, remove the key, and wait for all moving parts to stop before leaving the operating position.
3. Raise the seat.
4. Clean the debris and grass from the hydraulic unit shrouds ([Figure 78](#)).
5. Lower the seat.

Brake Maintenance

Adjusting the Parking Brake

Service Interval: After the first 100 hours

Every 500 hours thereafter

Check to make sure the brake is adjusted properly before adjusting.

Note: This procedure must be followed after the first 100 hours or when a brake component has been removed or replaced.

1. Drive the machine onto a level surface.
2. Disengage the blade-control switch (PTO), move the motion-control levers to the neutral-locked position and engage the parking brake.
3. Stop the engine, wait for all moving parts to stop, and remove the key.
4. Raise the back of the machine up and support the machine with jack stands.

⚠ DANGER

Mechanical or hydraulic jacks may fail to support machine and cause a serious injury.

- Use jack stand when supporting machine.
- Do not use hydraulic jacks.

5. Remove the rear tires from the machine.
6. Remove any debris from the brake area.
7. Rotate the drive wheel release handle to the released position. Refer to [Using the Drive Wheel Release Valves \(page 26\)](#).
8. Check to see if there is a visible gap between the L-bracket and the linkage stop ([Figure 79](#)).

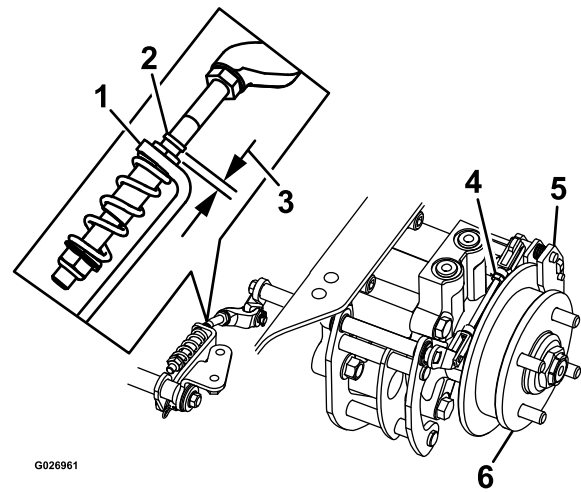

Figure 79
Left Side Shown

1. L-bracket
 2. Linkage stop
 3. Gap
 4. Rear linkage assembly
 5. Caliper
 6. Wheel hub
-
9. Disengage the parking brake, the lever should be in the down position.
 10. Turn the wheel hub by hand in both directions relative to the caliper; the wheel hub should move freely between the caliper.
 11. If a gap is needed or the wheel hub does not move freely:
 - A. Disengage the parking brake.
 - B. Disconnect and fine-tune the rear linkage assembly:
 - Shorten the link to create a gap.
 - Lengthen the link to allow wheel hub movement.
 - C. Reconnect the rear linkage assembly.
 12. Engage the parking brake and check the gap.
 13. Repeat steps 9 through 13 until a visible gap is achieved and the wheel hub rotates freely.
 14. Repeat this procedure for the brake on the opposite side.
 15. Rotate the drive wheel release handle to the operating position. Refer to [Using the Drive Wheel Release Valves \(page 26\)](#).
 16. Install the rear tires and torque the lug nuts. Refer to [Checking the Wheel Lug Nuts \(page 46\)](#).
 17. Remove the jack stands.

Belt Maintenance

Inspecting the Belts

Service Interval: Every 50 hours

Check the belts for squealing when the belt is rotating, blades slipping when cutting grass, frayed belt edges, burn marks, and cracks. These are signs of a worn mower belt; replace the mower belt if any of these conditions are evident.

Replacing the Mower Belt

Squealing when the belt is rotating, blades slipping when cutting grass, frayed belt edges, burn marks, and cracks are signs of a worn mower belt. Replace the mower belt if any of these conditions are evident.

1. Disengage the PTO, move the motion-control levers to the neutral-locked position, and set the parking brake.
2. Stop the engine, remove the key, and wait for all moving parts to stop before leaving the operating position.
3. Lower the mower to the 76 mm (3 inch) height of cut.
4. Remove the belt covers (Figure 80).

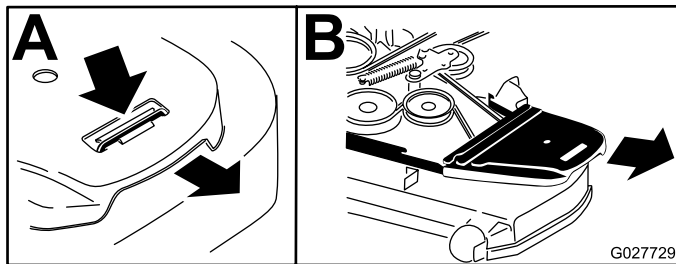

Figure 80

1. Push tab down
2. Remove belt cover

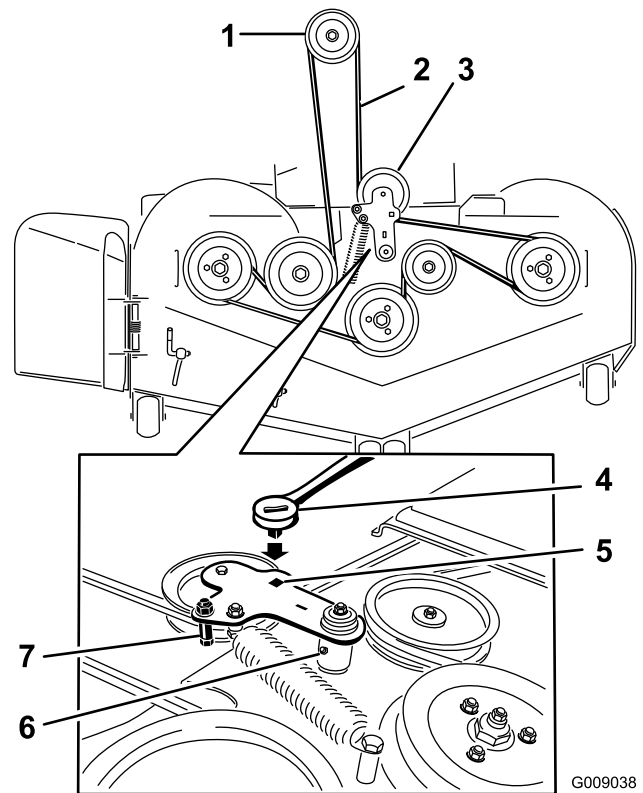

Figure 81

1. Clutch pulley
2. Mower belt
3. Spring-loaded idler pulley
4. Ratchet
5. Square hole in the idler arm for the ratchet
6. Idler grease fitting
7. Belt guide

10. Install the belt guide on the idler arm shown in Figure 81.
11. Using the ratchet in the square hole, install the idler spring (Figure 81).
Make sure that the spring ends are seated in the anchor grooves.
12. Install the belt covers (Figure 82).

5. Use a ratchet in the square hole in the idler arm to remove tension on the idler spring (Figure 81).
6. Remove the belt from the mower deck pulleys.
7. Remove the belt guide on the spring-loaded idler arm shown in Figure 81.
8. Remove the existing belt.
9. Install the new belt around the mower pulleys and the clutch pulley under the engine (Figure 81).

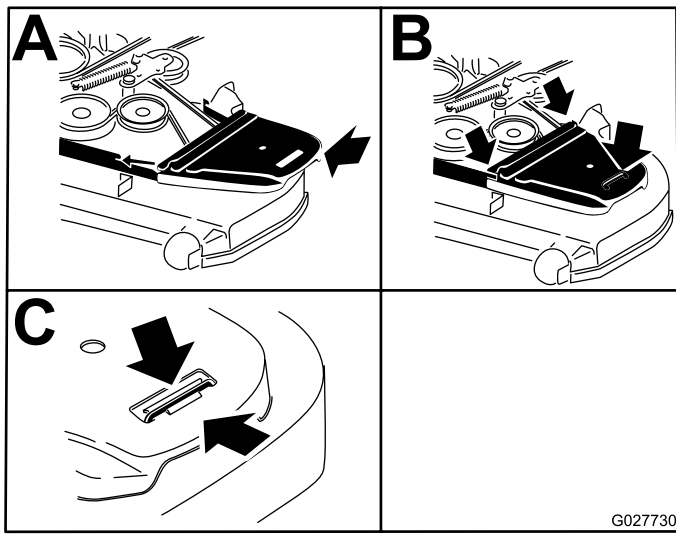

Figure 82

1. Position the belt cover
2. Slide belt cover under the side catches
3. Ensure that the tab is under the metal catch

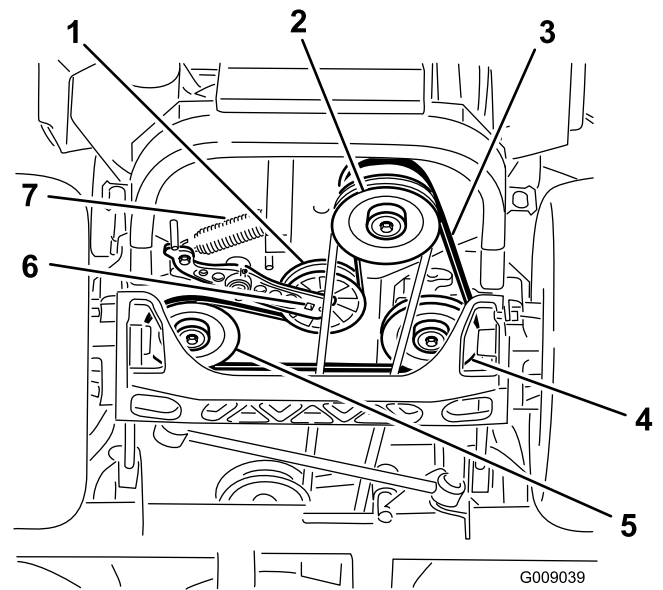

Figure 83

1. Idler pulley
2. Clutch pulley
3. Pump drive belt
4. Right-hand hydraulic pump pulley
5. Left-hand hydraulic pump pulley
6. Square hole in idler arm
7. Idler spring

Replacing the Hydraulic Pump Drive Belt

1. Disengage the PTO and set the parking brake.
2. Stop the engine, remove the key, and wait for all moving parts to stop before leaving the operating position.
3. Remove the mower belt. Refer to Replacing the Mower Belt in Maintenance.
4. Raise the machine and support it with jack stands (Figure 83).
5. Use a ratchet in the square hole in the idler arm to remove the idler spring (Figure 83).
6. Unhook the idler spring from the frame (Figure 83).
7. Remove the belt from the hydraulic unit drive pulleys and the engine pulley
8. Install the new belt around engine pulley and the two drive pulleys.
9. Using a ratchet in the square hole in the idler arm, install the idler spring to the frame (Figure 83).
10. Install the mower belt. Refer to Replacing the Mower Belt.

Controls System Maintenance

Adjusting the Control Handle Position

There are 2 height positions for the control levers: high and low. Remove the bolts to adjust the height for the operator.

1. Disengage the PTO, move the motion-control levers to the neutral-locked position, and set the parking brake.
2. Stop the engine, remove the key, and wait for all moving parts to stop before leaving the operating position.
3. Loosen the bolts and flange nuts installed in the levers (Figure 84).
4. Align the front-to-rear position of the levers by bringing the levers together to the neutral position and sliding them until they are aligned; then tighten the bolts (Figure 85).

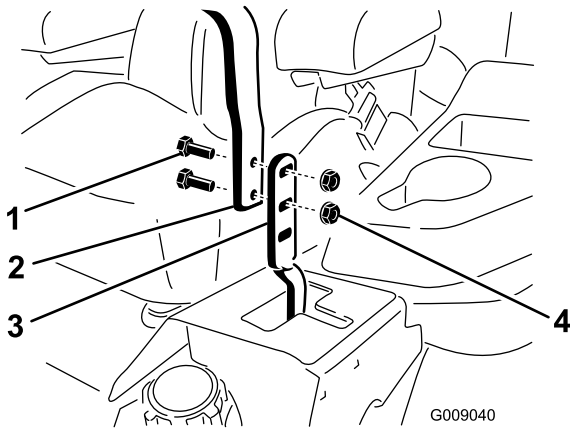

Figure 84

- | | |
|-----------|------------------|
| 1. Bolt | 3. Control lever |
| 2. Handle | 4. Nut |

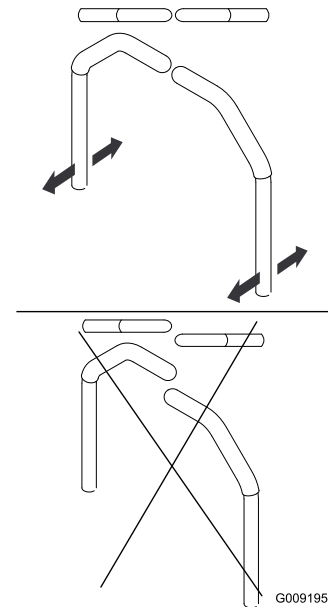

Figure 85

Adjusting the Motion-Control Linkage

Located on either side of the fuel tank, below the seat are the pump control linkages. Rotating the pump linkage with a 1/2 inch wrench allows fine tuning adjustments so that the machine does not move in neutral. Any adjustments should be made for neutral positioning only.

⚠ WARNING

The engine must be running and the drive wheels must be turning so that the motion control adjustment can be performed. Contact with moving parts or hot surfaces may cause personal injury.

Keep fingers, hands, and clothing clear of rotating components and hot surfaces.

1. Prior to starting the engine, push the deck lift pedal, remove the height-of-cut pin, and lower the deck to the ground.
2. Raise the rear of the machine up and support it with jack stands (or equivalent support) just high enough to allow the drive wheels to turn freely.
3. Remove the electrical connection from the seat safety switch, located under the bottom cushion of the seat.

Note: The switch is a part of the seat assembly.

4. **Temporarily** install a jumper wire across the terminals in the connector of the main wiring harness.
5. Start the engine.

Note: The brake must be engaged, and the motion-control levers out, to start the engine. The operator does not have to be in the seat because of

the jumper wire being used. Run the engine at full throttle and release the brake.

- Run the machine at least 5 minutes with the drive levers at full forward speed to bring hydraulic oil up to operating temperature.

Note: The motion-control lever needs to be in neutral while making any necessary adjustments.

- Bring the motion-control levers into the neutral position.
- Adjust the pump control rod lengths by rotating the double nuts on the rod in the appropriate direction until the wheels slightly creep in reverse (Figure 86).

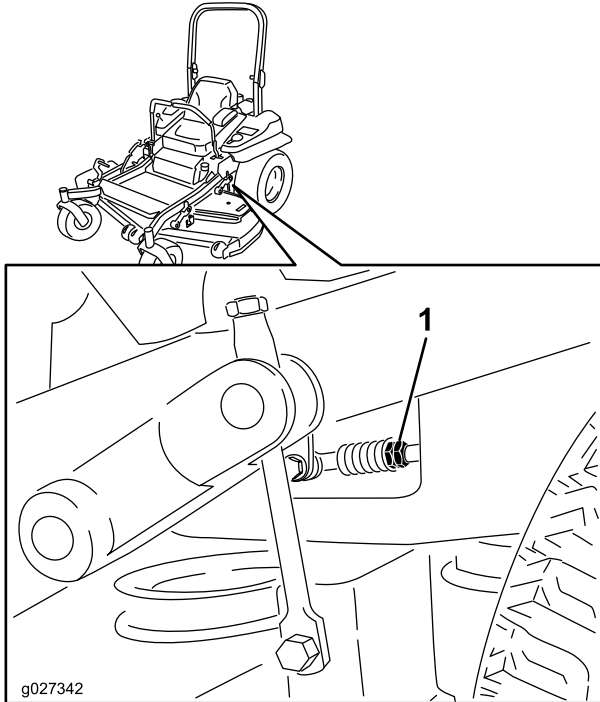

Figure 86

- Double nuts

- Move the motion-control levers to the reverse position and while applying slight pressure to the lever allow the reverse indicator springs to bring the levers back to neutral.

Note: The wheels must stop turning or slightly creep in reverse.

- Stop the engine, remove the jumper wire from the wire harness, and plug the connector into the seat switch.
- Remove the jack stands.
- Raise the deck and install the height-of-cut pin.
- Check that the machine does not creep in neutral with the parking brake disengaged.

Adjusting the Motion-Control Damper

The top damper mounting bolt can be adjusted to obtain a more desired motion-control lever resistance. See Figure 87 for mounting options.

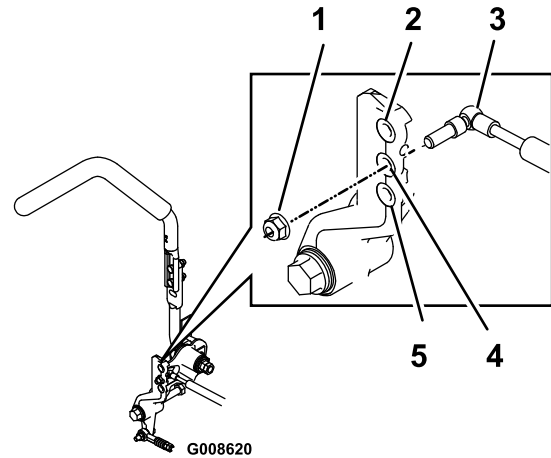

Figure 87

Right-hand motion control shown

- Torque the locknut to 23 N-m (17 ft-lb). The bolt must protrude past the end of the locknut after torquing.
- Most resistance (firmest feel)
- Damper
- Medium resistance (medium feel)
- Least resistance (softest feel)

Adjusting the Motion-Control Neutral Lock Pivot

The flanged nut can be adjusted to obtain a more desired motion-control lever resistance when moving it to the neutral lock position. See Figure 88 for adjustment options.

- Loosen the jam nut.
- Tighten or loosen the flanged nut to the desired feel.
For more resistance, tighten the flanged nut.
For less resistance, loosen the flanged nut
- Tighten the jam nut.

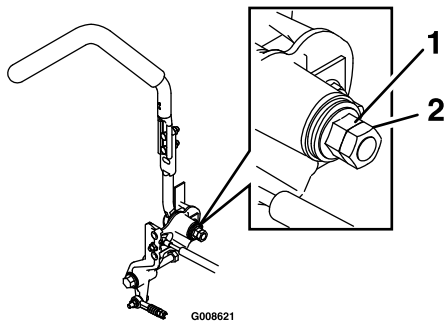

Figure 88

1. Flanged nut

2. Jam nut

Hydraulic System Maintenance

Servicing the Hydraulic System

Hydraulic Oil Type: Toro® HYPR-OIL™ 500 hydraulic oil or Mobil® 1 15W-50.

Important: Use oil specified. Other fluids could cause system damage.

Each Hydraulic System Oil Capacity: 1.5 L (1.59 US qt) per side with filter change

Checking the Hydraulic Oil

Service Interval: Every 50 hours—Check the hydraulic oil level.

1. Position the machine on a level surface.
2. Disengage the PTO, move the motion-control levers to the neutral-locked position and set the parking brake.
3. Stop the engine, remove the key, and wait for all moving parts to stop before leaving the operating position.
4. Allow the engine and the hydraulic system to cool for 10 minutes.

Note: The oil level on the dipstick will be incorrect if the oil is checked when the machine is hot.

5. Move the seat forward.
6. Clean the area around the dipsticks of the hydraulic-system reservoirs (Figure 89).
7. Remove one dipstick from the hydraulic reservoir (Figure 89).
8. Wipe the dipstick off and thread the dipstick into the reservoir.
9. Remove the dipstick and look at the end (Figure 89). If the oil level is at the add mark, slowly pour only enough oil into the hydraulic reservoir to raise the level to the full or **H** line.

Important: Do not overfill the hydraulic units with oil as damage may occur. Do not run the machine with the oil below the add mark.

10. Install the dipstick.
11. Repeat procedure for the opposite dipstick.

Replacing the Hydraulic Filters and Hydraulic Oil

Service Interval: After the first 250 hours—Change the hydraulic filters and hydraulic oil when using any type of oil.

Every 250 hours—Change the hydraulic filters and hydraulic oil when using Mobil® 1 oil (more often in dirty or dusty conditions).

Every 500 hours—Change the hydraulic filters and hydraulic oil when using Toro® HYPR-OIL™ 500 hydraulic oil (more often in dirty or dusty conditions).

To replace the hydraulic oil, the filters need to be removed. Replace both at the same time. Refer to the oil specifications under [Servicing the Hydraulic System \(page 55\)](#) for the correct oil.

1. Disengage the blade-control switch (PTO), move the motion-control levers to the neutral-locked position and set the parking brake.
2. Stop the engine, remove the key, and wait for all moving parts to stop before leaving the operating position.
3. Raise the machine and support it with jack stands ([Figure 90](#)).

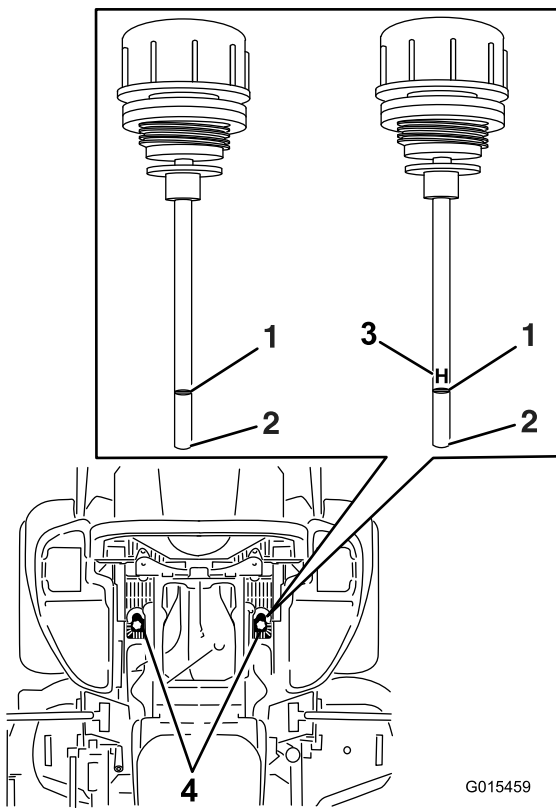

Figure 89

Either dipstick will be used in the machine

- | | |
|---------|----------------------------------|
| 1. Full | 3. H—means high level |
| 2. Add | 4. Dipstick locations under seat |

⚠ WARNING

Hydraulic oil escaping under pressure can penetrate skin and cause injury.

- If hydraulic oil is injected into the skin it must be surgically removed within a few hours by a doctor familiar with this type of injury. Gangrene may result if this is not done.
- Keep body and hands away from pin hole leaks or nozzles that eject high pressure hydraulic oil.
- Use cardboard or paper to find hydraulic leaks.
- Safely relieve all pressure in the hydraulic system before performing any work on the hydraulic system.
- Make sure all hydraulic oil hoses and lines are in good condition and all hydraulic connections and fittings are tight before applying pressure to hydraulic system.

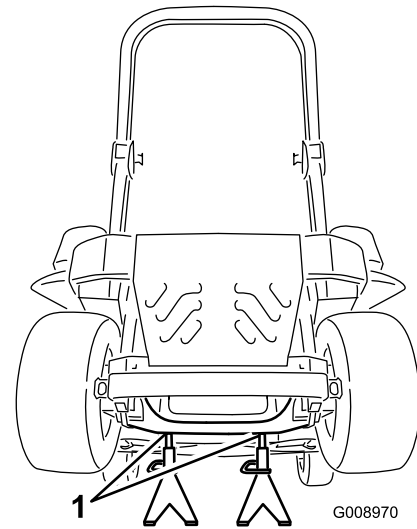

Figure 90

1. Jack stands
4. Remove both the mower belt and the pump drive belt. This will prevent oil getting on the belts. Refer to [Belt Maintenance \(page 51\)](#).
5. Place a drain pan under the filter, remove the old filter and wipe the surface clean ([Figure 91](#)).

Mower Deck Maintenance

Leveling the Mower Deck

Setting Up the Machine

Note: Ensure that the mower deck is leveled before matching the height of cut (HOC).

1. Position the machine on a flat surface.
2. Disengage the blade-control switch (PTO), move the motion-control levers to the neutral-locked position and set the parking brake.
3. Stop the engine, remove the key, and wait for all moving parts to stop before leaving the operating position.
4. Check the tire pressure of the drive tires. If needed, adjust the pressure to 90 kPa (13 psi)
5. Position the mower to the 76 mm (3 inch) height-of-cut position.

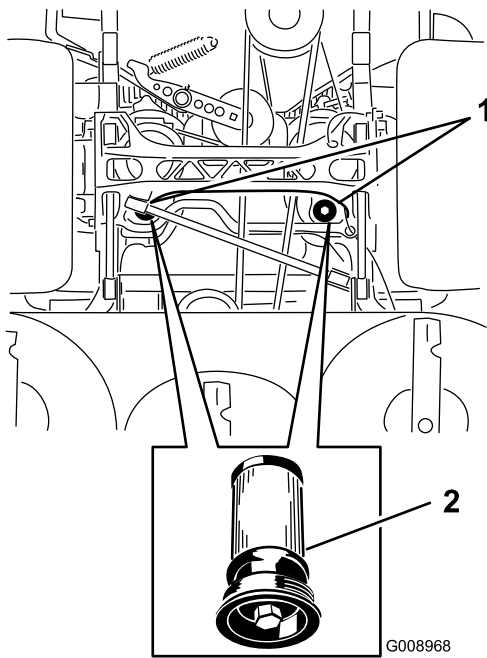

Figure 91

Bottom View of Machine

1. Filter locations
2. Hydraulic filter

6. Apply a thin coat of hydraulic oil to the rubber gasket on the replacement filter (Figure 91).
7. Install the replacement hydraulic filter.
8. Install the pump drive belt and the mower belt.
9. Remove the jack stands and lower the machine (Figure 90).
10. Add oil to the hydraulic reservoir and check for any leaks.
11. Clean up any spilled oil.
12. Start the engine and let it run for about two minutes to purge air from the system. Stop the engine and check for leaks.
13. Check the oil level while the oil is cold.
14. If required, add oil to the hydraulic reservoir. Do not overfill.

Leveling the Deck

1. Position the mower on a flat surface.
2. Stop engine, wait for all moving parts to stop, and remove key. Engage parking brake.
3. Check the tire pressure in the drive tires. Proper inflation pressure for tires is 90 kPa (13 psi). Adjust if necessary.
4. Position the transport lock in the latching position.
5. Push the deck lift pedal all the way forward and the deck will latch at the 14 cm (5-1/2 inch) transport position (Figure 92).

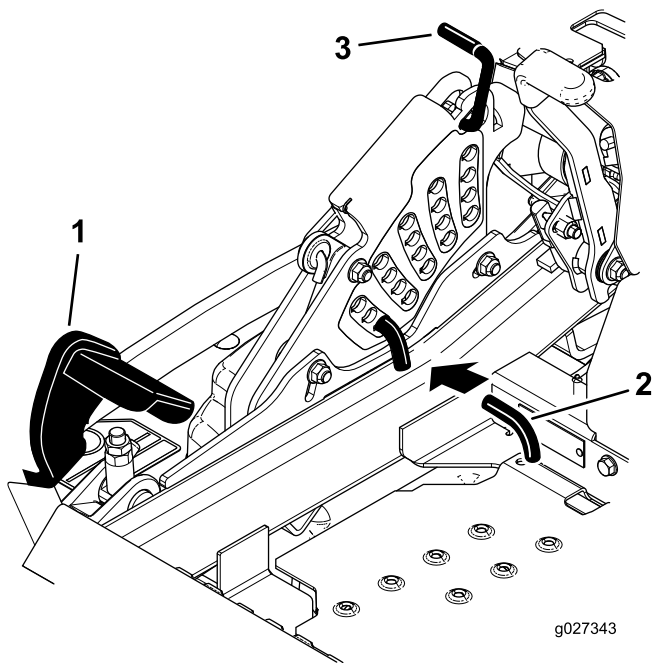

Figure 92

- 1. Deck-lift pedal
- 2. Height-of-cut pin
- 3. Transport lock

6. Insert the height-adjustment pin into the 7.6 cm (3 inch) cutting-height position.
7. Release the transport lock and allow the deck to lower to the cutting height.
8. Raise the discharge chute.
9. On both sides of the deck, measure from the level surface to the front tip of the blade (Position A). The measurement should read 7.6 mm (3 inches); refer to [Figure 93](#).

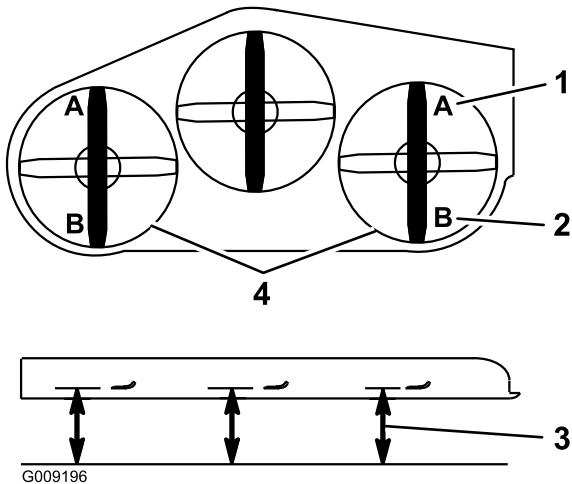

Figure 93

- 1. 7.6 cm (3 inches) at A is correct
- 2. 8.3 cm (3-1/4 inches) at B is correct
- 3. Measure here from the blade tip to hard surface
- 4. Measure at A and B on both sides

10. If needed, loosen the flanged locknut on the side of the yoke and the jam nut on top. Fine-tune the adjuster screw by turning it to get 7.6 mm (3 inch) height ([Figure 94](#)).

To increase the height, turn the adjuster screw clockwise; to decrease the height, turn it counterclockwise.

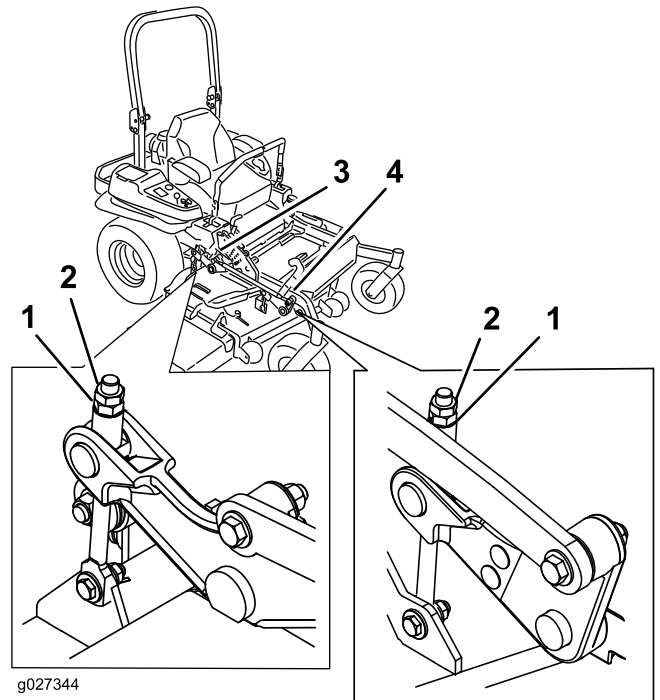

Figure 94

- 1. Flanged locknut
- 2. Adjuster screw
- 3. Jam nut
- 4. Yoke

11. If the front deck links do not have enough adjustment to achieve accurate cut height, the single point adjustment can be utilized to gain more adjustment.
12. To adjust the single point system, loosen the two bolts at the bottom of the height-of-cut plate. Refer to [Figure 95](#).

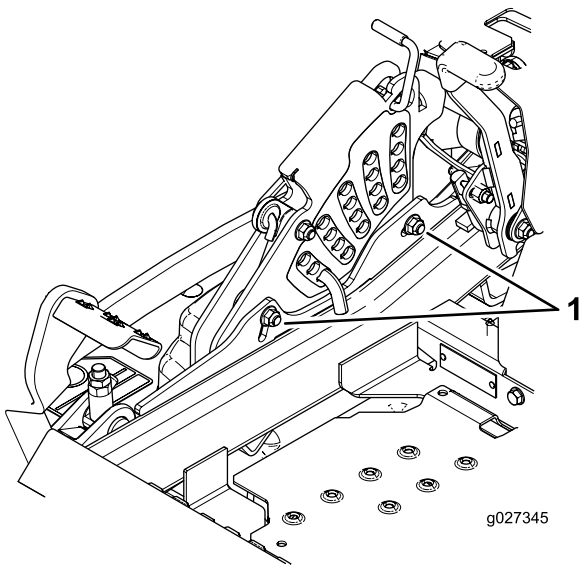

Figure 95

1. Bolts at the bottom of the height-of-cut plate

13. If the deck is too low, tighten the single point adjustment bolt by rotating it clockwise. If the deck is too high, loosen the single point adjustment bolt by rotating it counterclockwise (Figure 96).

Note: Loosen or tighten the single point adjustment bolt enough to move the height-of-cut plate mounting bolts at least 1/3 the length of the available travel in their slots. This will regain some up-and-down adjustment on each of the 4 deck links.

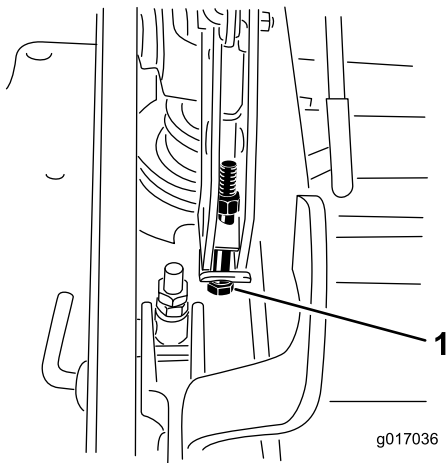

Figure 96

1. Single point adjustment bolt

14. Tighten the 2 bolts at the bottom of the height-of-cut plate (Figure 95). Torque them to 37 to 45 N·m (27 to 33 ft·lb).

Note: In most conditions, the back blade tip should be adjusted 6.4 mm (1/4 inch) higher than the front.

15. On both sides of the deck, measure from the level surface to the back tip of the blade (Position B). The

measurement should read 8.3 cm (3-1/4 inches); refer to Figure 93.

16. Fine-tune the adjuster screw by turning it to get 8.3 mm (3-1/4 inches) height (Figure 94).

To increase the height, turn the adjustment nut clockwise; to decrease the height, turn the nut counterclockwise.

17. Measure until all 4 sides are the correct height. Tighten all the jam nuts on the deck-lift arm assemblies.
18. Lower the discharge chute.

Servicing the Cutting Blades

Maintain sharp blades throughout the cutting season, because sharp blades cut cleanly without tearing or shredding the grass blades. Tearing and shredding turns grass brown at the edges, which slows growth and increases the chance of disease.

Check the cutter blades daily for sharpness, and for any wear or damage. File down any nicks and sharpen the blades as necessary. If a blade is damaged or worn, replace it immediately with a genuine Toro replacement blade. For convenient sharpening and replacement, you may want to keep extra blades on hand.

▲ DANGER

A worn or damaged blade can break, and a piece of the blade could be thrown into the operator's or bystander's area, resulting in serious personal injury or death.

- Inspect the blade periodically for wear or damage.
- Replace a worn or damaged blade.

Before Inspecting or Servicing the Blades

Park the machine on a level surface, disengage the blade-control switch (PTO), and set the parking brake. Turn the ignition key to Off. Remove the key.

Inspecting the Blades

Service Interval: Before each use or daily

1. Inspect the cutting edges (Figure 97). If the edges are not sharp or have nicks, remove and sharpen the blades. Refer to Sharpening the Blades.
2. Inspect the blades, especially the curved area (Figure 97). If you notice any damage, wear, or a slot forming in this area (Figure 97), immediately install a new blade.

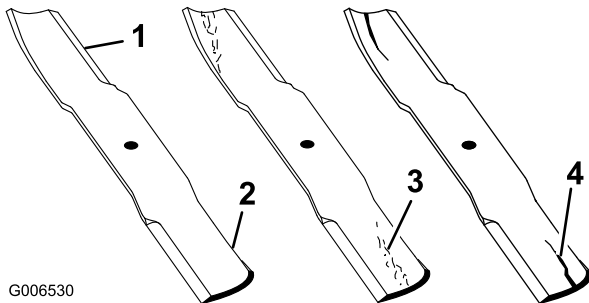

Figure 97

1. Cutting edge
2. Curved area
3. Wear/slot forming
4. Crack

Checking for Bent Blades

1. Disengage the blade-control switch (PTO), move the motion-control levers to the neutral-locked position and set the parking brake.
2. Stop the engine, remove the key, and wait for all moving parts to stop before leaving the operating position.
3. Rotate the blades until the ends face forward and backward (Figure 98). Measure from a level surface to the cutting edge, position A, of the blades (Figure 98). Note this dimension.

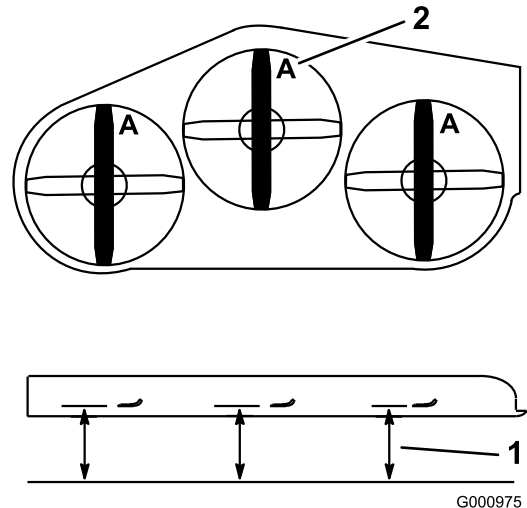

Figure 98

1. Measure here from blade to hard surface
2. Position A

4. Rotate the opposite ends of the blades forward.
5. Measure from a level surface to the cutting edge of the blades at the same position as in step 3 above. The difference between the dimensions obtained in steps 3 and 4 must not exceed 1/8 inch (3 mm). If this dimension exceeds 1/8 inch (3 mm), the blade is bent and must be replaced; refer to Removing the Blades and Installing the Blades.

▲ WARNING

A blade that is bent or damaged could break apart and could seriously injure or kill you or bystanders.

- Always replace bent or damaged blade with a new blade.
- Never file or create sharp notches in the edges or surfaces of blade.

Removing the Blades

Blades must be replaced if a solid object is hit, if the blade is out of balance or is bent. To ensure optimum performance and continued safety conformance of the machine, use genuine Toro replacement blades. Replacement blades made

by other manufacturers may result in non-conformance with safety standards.

1. Hold the blade end using a rag or thickly-padded glove.
2. Remove the blade bolt, curved washer, and blade from the spindle shaft (Figure 99).

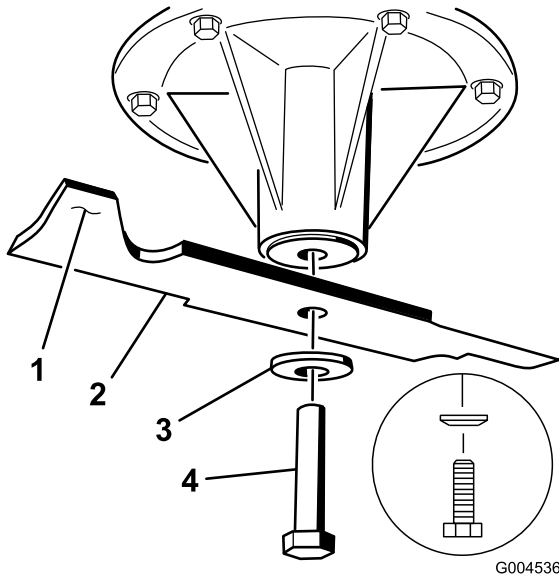

Figure 99

- | | |
|-----------------------|------------------|
| 1. Sail area of blade | 3. Curved washer |
| 2. Blade | 4. Blade bolt |

blade is not balanced, file some metal off the end of the sail area only (Figure 102). Repeat this procedure until the blade is balanced.

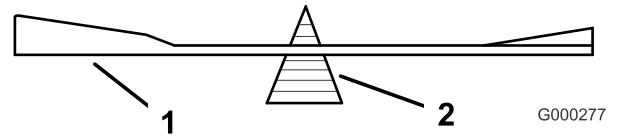

Figure 101

- | | |
|----------|-------------|
| 1. Blade | 2. Balancer |
|----------|-------------|

Sharpening the Blades

⚠ WARNING

When sharpening blades, pieces of a blade could be thrown and cause serious injury.

Wear proper eye protection when sharpening blades.

1. Use a file to sharpen the cutting edge at both ends of the blade (Figure 100). Maintain the original angle. The blade retains its balance if the same amount of material is removed from both cutting edges.

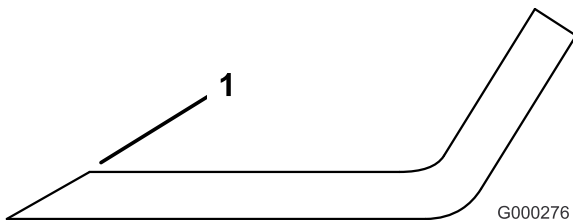

Figure 100

1. Sharpen at original angle

2. Check the balance of the blade by putting it on a blade balancer (Figure 101). If the blade stays in a horizontal position, the blade is balanced and can be used. If the

Installing the Blades

1. Install the blade onto the spindle shaft (Figure 102).

Important: The curved part of the blade must be pointing upward toward the inside of the mower to ensure proper cutting.

2. Install the spring disk and the blade bolt. The spring disk cone must be installed toward the bolt head (Figure 102). Torque the blade bolt to 115 to 150 N-m (85 to 110 ft-lb).

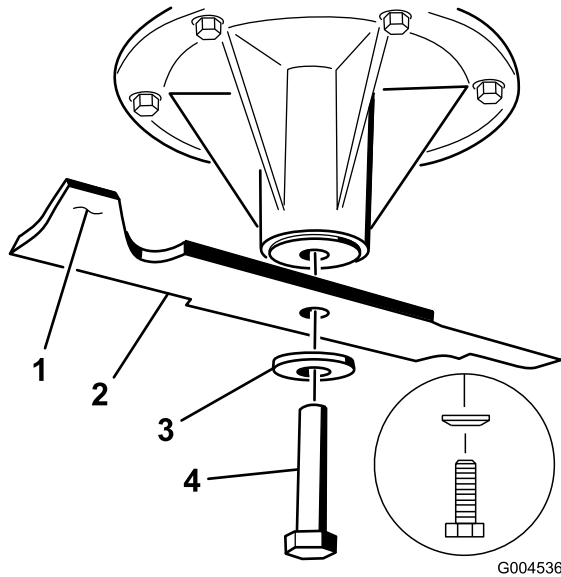

Figure 102

- | | |
|-----------------------|---------------------------|
| 1. Sail area of blade | 4. Blade bolt |
| 2. Blade | 5. Cone towards bolt head |
| 3. Curved washer | |

Removing the Mower Deck

Before servicing or removing the mower deck, the spring-loaded deck arms must be locked out.

⚠ WARNING

Deck lift arm assemblies have stored energy. Removing the deck with out releasing the stored energy can cause serious injury or death.

Do not attempt to disassemble the deck from the front frame without locking out the stored energy.

1. Stop the engine, wait for all moving parts to stop, and remove the key. Engage the parking brake.
2. Remove the height-adjustment pin and lower the deck to the ground.
3. Place the height-adjustment pin in the 7.6 cm (3 inch) cutting-height location.

Note: This locks the deck lift arms in the lowest position when the deck is removed and the stored energy in the deck spring is released.

4. Remove the belt covers.
5. Lift up the floor pan and insert a ratchet into the square hole in the deck idler (Figure 103).
6. Rotate the deck idler clockwise and remove the mower belt (Figure 103).

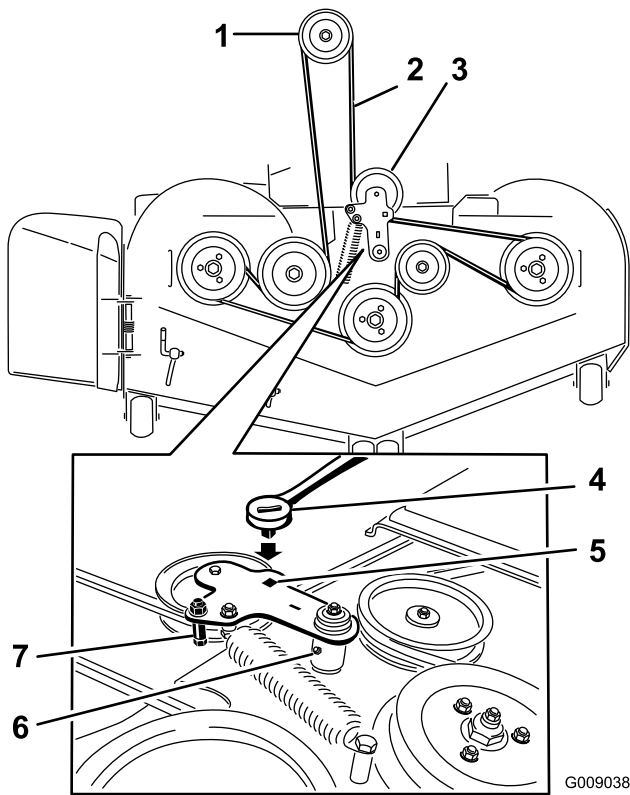

Figure 103

- | | |
|-------------------------------|---|
| 1. Clutch pulley | 5. Square hole in the idler arm for the ratchet |
| 2. Mower belt | 6. Idler grease fitting |
| 3. Spring-loaded idler pulley | 7. Belt guide |
| 4. Ratchet | |

7. Remove and retain the hardware on both sides of the deck as shown in [Figure 104](#) or [Figure 105](#).

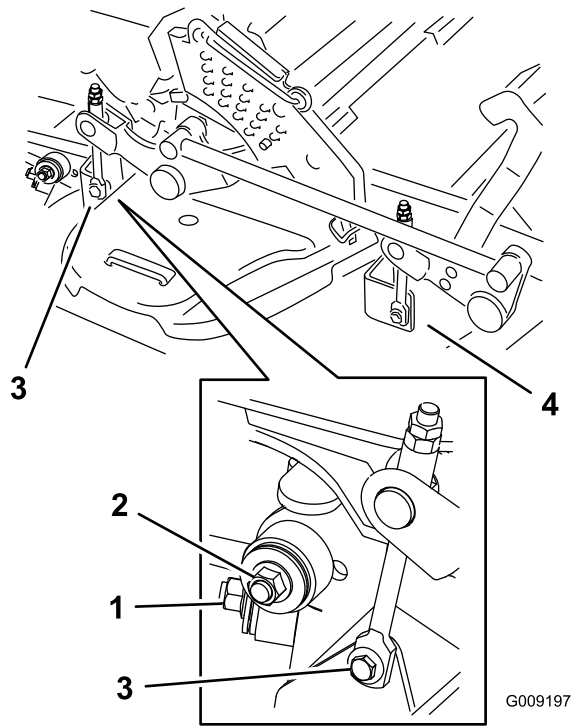

Figure 104

1. Right stabilizer
2. Deck strut (right side shown)
3. Remove the rear deck lift attachment shoulder bolt and nut.
4. Remove the front deck lift attachment shoulder bolt and nut.

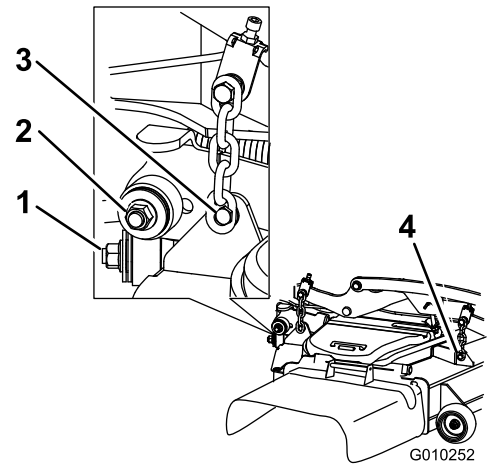

Figure 105

1. Right stabilizer
2. Deck strut (right side shown)
3. Remove the rear deck lift attachment shoulder bolt and nut.
4. Remove the front deck lift attachment shoulder bolt and nut.

8. Raise the deck struts and secure them in the up position. Slide the deck out to the right side of the machine.

Replacing the Grass Deflector

⚠ WARNING

Operating the machine with the engine running at a speed greater than the factory setting can cause the machine to throw a part of the blade or engine toward the operator or a bystander and result in serious personal injury or death.

Never operate the machine unless you install a cover plate, a mulch plate, a grass deflector, or a bagger.

1. Remove the locknut, bolt, spring, and spacer holding the deflector to the pivot brackets (Figure 106). Remove the damaged or worn grass deflector.

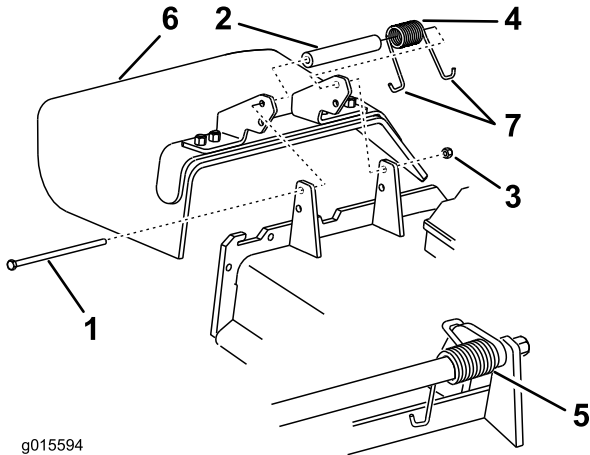

Figure 106

- | | |
|------------|-------------------------|
| 1. Bolt | 5. Spring installed |
| 2. Spacer | 6. Grass deflector |
| 3. Locknut | 7. J-hook end of spring |
| 4. Spring | |

2. Place the spacer and the spring onto the grass deflector. Place one J end of the spring behind the deck edge.

Note: Make sure one J-end of the spring is installed behind the deck edge before installing the bolt as shown in Figure 106.

3. Install the bolt and the nut. Place one J-hook end of the spring around the grass deflector (Figure 106).

Important: The grass deflector must be able to rotate. Lift the deflector up to the full open position and ensure that it rotates into the full down position.

Cleaning

Cleaning under the Mower

Service Interval: Before each use or daily

1. Disengage the blade-control switch (PTO), move the motion-control levers to the neutral-locked position and set the parking brake.
2. Stop the engine, remove the key, and wait for all moving parts to stop before leaving the operating position.
3. Raise the mower to the transport position.

Disposing of Waste

Engine oil, batteries, hydraulic oil, and engine coolant are pollutants to the environment. Dispose of these according to your state and local regulations.

Storage

Cleaning and Storage

1. Disengage the power take off (blade-control switch (PTO)), set the parking brake, and turn the ignition key to Off. Remove the key.
2. Remove grass clippings, dirt, and grime from the external parts of the entire machine, especially the engine and hydraulic system. Clean dirt and chaff from the outside of the engine cylinder head fins and blower housing.

Important: You can wash the machine with mild detergent and water. Do not pressure wash the machine. Avoid excessive use of water, especially near the control panel, engine, hydraulic pumps, and motors.

3. Check the brake; refer to [Brake Maintenance \(page 50\)](#).
4. Service the air cleaner; refer to [Servicing the Air Cleaner \(page 34\)](#).
5. Grease the machine; refer to [Lubrication \(page 31\)](#)
6. Change the crankcase oil; refer to [Changing the Engine Oil \(page 36\)](#).
7. Check the tire pressure; refer to [Checking the Tire Pressure \(page 45\)](#).
8. Change the hydraulic filters; refer to [Servicing the Hydraulic System \(page 55\)](#).
9. Charge the battery; refer to [Servicing the Battery \(page 41\)](#).
10. Scrape any heavy buildup of grass and dirt from the underside of the mower, then wash the mower with a garden hose.

Note: Run the machine with the blade-control switch (PTO) engaged and the engine at high idle for 2 to 5 minutes after washing.

11. Check the condition of the blades; refer to [Servicing the Cutting Blades \(page 60\)](#).
12. For storage over 30 days, prepare the machine as follows:
 - A. Add a petroleum-based stabilizer/conditioner to fuel in the tank. Follow the mixing instructions from the stabilizer manufacturer. Do not use an alcohol-based stabilizer (ethanol or methanol).

Note: A fuel stabilizer/conditioner is most effective when mixed with fresh fuel and used at all times.
 - B. Run the engine to distribute conditioned fuel through the fuel system (5 minutes).
 - C. Stop the engine, allow it to cool, and drain the fuel tank; refer to [Servicing the Fuel Tank \(page 41\)](#).

- D. Restart the engine and run it until it stops.
- E. Dispose of fuel properly. Recycle as per local codes.

Important: Do not store stabilizer/conditioned fuel over 90 days.

13. Check and tighten all bolts, nuts, and screws. Repair or replace any part that is damaged.
14. Paint all scratched or bare metal surfaces. Paint is available from your Authorized Service Dealer.
15. Store the machine in a clean, dry garage or storage area. Remove the key from the ignition switch and keep it out of reach of children or other unauthorized users. Cover the machine to protect it and keep it clean.

Troubleshooting

Problem	Possible Cause	Corrective Action
The malfunction Indicator Light (MIL) comes on.	<ol style="list-style-type: none"> 1. The engine is too hot. 2. There is old gas in the gas tank. 3. The fuel shut-off valve is not open completely. 4. The air cleaner is dirty. 5. The battery is not charged. 6. Incorrect fuel filters are being used or the fuel filters are dirty. 7. The connections to the sensors electronic control unit (ECU) and fuel injectors are not secured properly. 8. There is low voltage from the battery. 9. A fuse is blown. 	<ol style="list-style-type: none"> 1. Turn the engine off and let it cool. 2. Use new gas. 3. Open the fuel shut-off valve. 4. Make sure that the air cleaner and precleaner are clean. Replace if necessary. 5. Charge or replace the battery. 6. Contact an Authorized Service Dealer. 7. Contact an Authorized Service Dealer. 8. Ensure a good 12 volt battery is being used and is fully charged. 9. Check and replace any blown fuses.
The starter does not crank.	<ol style="list-style-type: none"> 1. The blade-control switch (PTO) is engaged. 2. The parking brake is not on. 3. The motion-control levers are not in the neutral-lock position. 4. The operator is not seated. 5. The battery is dead. 6. The electrical connections are corroded or loose. 7. The fuse is blown. 8. The relay or switch is worn or damaged. 	<ol style="list-style-type: none"> 1. Move the blade-control switch (PTO) to the disengaged position. 2. Set the parking brake. 3. Ensure that the motion-control levers are in the neutral-lock position. 4. Sit on the seat. 5. Charge the battery. 6. Check the electrical connections for good contact. 7. Replace the fuse. 8. Contact an Authorized Service Dealer.
The engine does not start, starts hard, or fails to keep running.	<ol style="list-style-type: none"> 1. The fuel tank is empty. 2. The fuel-shutoff valve is closed. 3. The oil level in the crankcase is low. 4. The throttle is not in the correct position. 5. There is dirt in the fuel filter. 6. There is dirt, water, or stale fuel in the fuel system. 7. The air cleaner is dirty. 8. The seat switch is not functioning properly. 9. The electrical connections are corroded, loose, or damaged. 10. The relay or switch is worn or damaged. 11. The spark plug is fouled or improperly gapped. 12. The spark-plug wire is not connected. 	<ol style="list-style-type: none"> 1. Fill the fuel tank. 2. Open the fuel-shutoff valve. 3. Add oil to the crankcase. 4. Be sure that the throttle control is midway between the slow and fast positions. 5. Replace the fuel filter. 6. Contact an Authorized Service Dealer. 7. Clean or replace the air-cleaner element. 8. Check the seat-switch indicator. Replace the seat if necessary. 9. Check the electrical connections for good contact. Clean the connector terminals thoroughly with electrical-contact cleaner, apply dielectric grease, and make the appropriate connections. 10. Contact an Authorized Service Dealer. 11. Adjust or replace the spark plug. 12. Check the spark-plug wire connection.

Problem	Possible Cause	Corrective Action
The engine loses power.	<ol style="list-style-type: none"> 1. The engine load is excessive. 2. The air cleaner is dirty. 3. The oil level in the crankcase is low. 4. The cooling fins and the air passages above the engine are plugged. 5. The vent hole in the fuel cap is plugged. 6. There is dirt in the fuel filter. 7. There is dirt, water, or stale fuel in the fuel system. 	<ol style="list-style-type: none"> 1. Reduce the ground speed. 2. Clean the air-cleaner element. 3. Add oil to the crankcase. 4. Remove the obstruction from the cooling fins and the air passages. 5. Clean or replace the fuel cap. 6. Replace the fuel filter. 7. Contact an Authorized Service Dealer.
The engine overheats.	<ol style="list-style-type: none"> 1. The engine load is excessive. 2. The oil level in the crankcase is low. 3. The cooling fins and the air passages above the engine are plugged. 	<ol style="list-style-type: none"> 1. Reduce the ground speed. 2. Add oil to the crankcase. 3. Remove the obstruction from the cooling fins and the air passages.
The mower pulls to the left or right (with levers fully forward)	<ol style="list-style-type: none"> 1. The tracking needs adjustment 2. The tire pressure in the drive tires is not correct. 	<ol style="list-style-type: none"> 1. Adjust the tracking. 2. Adjust the tire pressure in the drive tires.
The machine does not drive.	<ol style="list-style-type: none"> 1. The bypass valves are not closed tight. 2. The pump belt is worn, loose, or broken. 3. The pump belt is off a pulley. 4. The idler spring is broken or missing. 5. The hydraulic oil level is low or too hot. 	<ol style="list-style-type: none"> 1. Tighten the bypass valves. 2. Change the belt. 3. Change the belt. 4. Replace the spring. 5. Add hydraulic oil to the reservoirs or let it cool down.
The machine vibrates abnormally.	<ol style="list-style-type: none"> 1. The cutting blade(s) is/are bent or unbalanced. 2. The blade mounting bolt is loose. 3. The engine mounting bolts are loose. 4. The engine pulley, idler pulley, or blade pulley is loose. 5. The engine pulley is damaged. 6. The blade spindle is bent. 7. The motor mount is loose or worn. 	<ol style="list-style-type: none"> 1. Install new cutting blade(s). 2. Tighten the blade mounting bolt. 3. Tighten the engine mounting bolts. 4. Tighten the appropriate pulley. 5. Contact an Authorized Service Dealer. 6. Contact an Authorized Service Dealer. 7. Contact an Authorized Service Dealer.
The machine produces an uneven cutting height.	<ol style="list-style-type: none"> 1. The blade(s) is/are not sharp. 2. The cutting blade(s) is/are bent. 3. The mower deck is not level. 4. The underside of mower is dirty. 5. The tire pressure is not correct. 6. The blade spindle is bent. 	<ol style="list-style-type: none"> 1. Sharpen the blade(s). 2. Install new cutting blade(s). 3. Level the mower deck from side-to-side and front-to-rear. 4. Clean the underside of the mower. 5. Adjust the tire pressure. 6. Contact an Authorized Service Dealer.
The blades do not rotate.	<ol style="list-style-type: none"> 1. The mower deck belt is worn, loose, or broken. 2. The mower deck belt is off pulley. 3. The pump drive belt is worn, loose, or broken. 4. The idler spring is broken or missing. 	<ol style="list-style-type: none"> 1. Install a new deck belt. 2. Install the mower deck pulley and check the idler pulley, idler arm, and spring for correct position and function. 3. Check the belt tension or install a new belt. 4. Replace the spring.

Problem	Possible Cause	Corrective Action
The clutch does not engage.	<ol style="list-style-type: none"> 1. The fuse is blown. 2. There is low voltage supply at the clutch. 3. The coil is damaged. 4. There is inadequate current supply. 5. The rotor/armature air gap is too large. 	<ol style="list-style-type: none"> 1. Replace the fuse. Check the coil resistance, battery charge, charging system, and wiring connections, and replace components if necessary. 2. Check the coil resistance, battery charge, charging system, and wiring connections and replace parts if necessary. 3. Replace the clutch. 4. Repair or replace the clutch lead wire or electrical system. Clean the connector contacts. 5. Remove the shim or replace the clutch.

Schematics

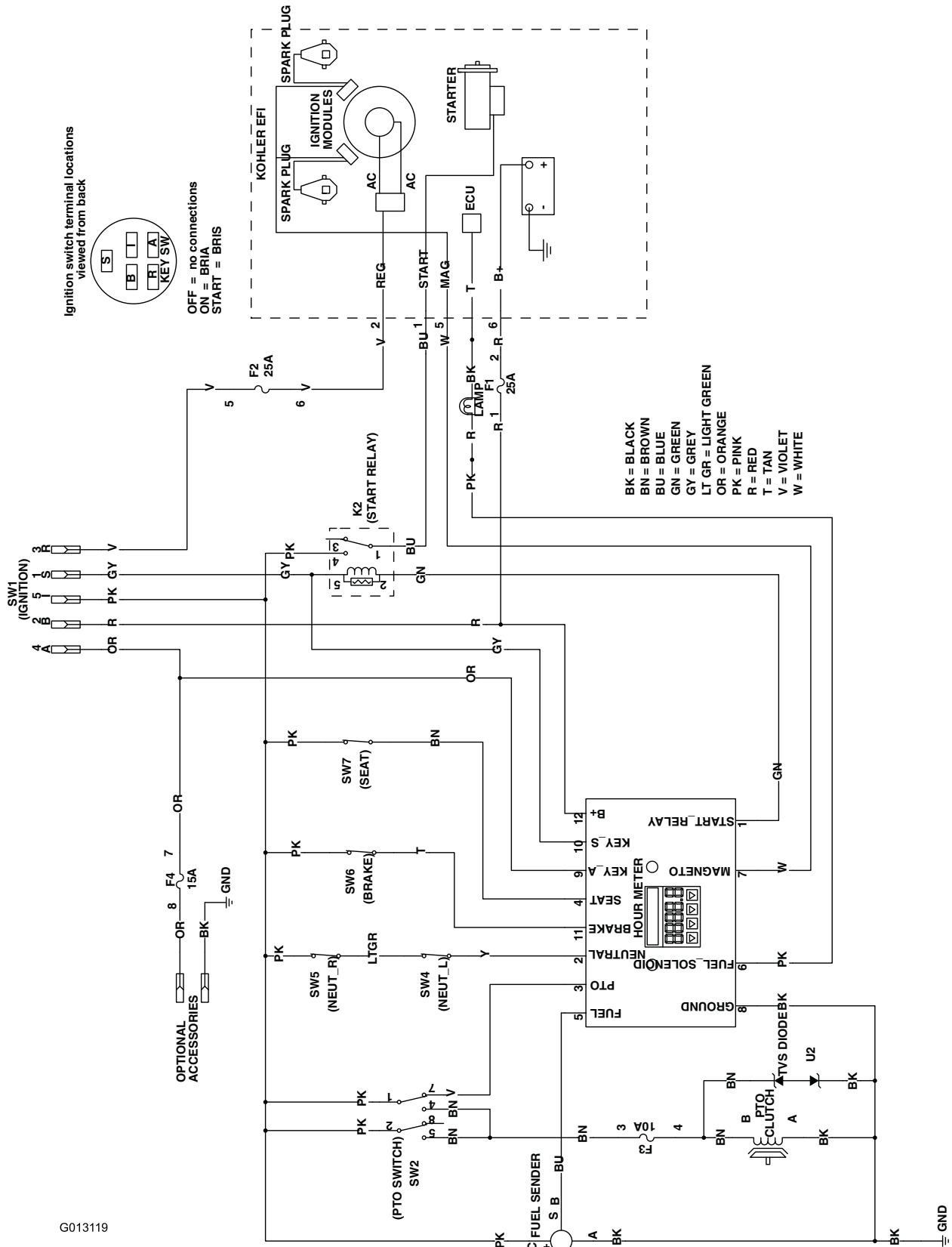

Wire Diagram (Rev. A)

G013119

Notes:

Notes:



The Toro Total Coverage Warranty

A Limited Warranty (see warranty periods below)

Landscape
Contractor
Equipment
(LCE)

Conditions and Products Covered

The Toro Company and its affiliate, Toro Warranty Company, pursuant to an agreement between them, jointly promise to the original purchaser to repair the Toro Products listed below if defective in materials or workmanship.

The following time periods apply from the date of purchase by the original owner:

Products	Warranty Period
21 in. Mowers	2 years Residential Use ¹ 1 year Commercial Use
• Engines ⁴	Honda – 2 years Kawasaki – 3 years
30 in. Mowers	2 years Residential Use ¹ 1 year Commercial Use
• Engines ⁴	Kawasaki – 3 years
Mid-Size Walk-Behind Mowers	2 years
• Engines ⁴	Kawasaki – 3 years
Grand Stand® Mowers	5 years or 1,200 hours ² 3 years
• Engines ⁴	Lifetime (original owner only) ³
• Frame	
Z Master® 2000 Series Mowers	4 years or 500 hours ² 3 years
• Engines ⁴	Lifetime (original owner only) ³
• Frame	
Z Master® 3000 Series Mowers	5 years or 1,200 hours ² 3 years
• Engines ⁴	Lifetime (original owner only) ³
• Frame	
Z Master® 5000 Series Mowers	5 years or 1,200 hours ² Kohler Command – 2 years Kohler EFI – 3 years
• Engines ⁴	Lifetime (original owner only) ³
• Frame	
Z Master® 6000 Series Mowers	5 years or 1,200 hours ² Kawasaki – 3 years
• Engines ⁴	Lifetime (original owner only) ³
• Frame	
Z Master® 7000 Series Mowers	5 years or 1,200 hours ² 2 years
• Engines ⁴	Lifetime (original owner only) ³
• Frame	
All Mowers	
• Battery	90 days Parts and Labor 1 year Parts only
• Belts and Tires	90 days
• Attachments	1 year

¹Residential use means use of the product on the same lot as your home. Use at more than one location is considered commercial use and the commercial warranty would apply.

²Whichever occurs first.

³Lifetime Frame Warranty - If the main frame, consisting of the parts welded together to form the tractor structure that other components such as the engine are secured to, cracks or breaks in normal use, it will be repaired or replaced, at Toro's option, under warranty at no cost for parts and labor. Frame failure due to misuse or abuse and failure or repair required due to rust or corrosion are not covered.

⁴Some engines used on Toro Products are warranted by the engine manufacturer.

Instructions for Obtaining Warranty Service

If you think that your Toro Product contains a defect in materials or workmanship, follow this procedure:

1. Contact any Authorized Toro Service Dealer to arrange service at their dealership. To locate a dealer convenient to you, refer to the Yellow Pages of your telephone directory (look under "Lawn Mowers") or access our web site at www.Toro.com. You may also call the numbers listed in item #3 to use the 24-hour Toro Dealer locator system.
2. Bring the product and your proof of purchase (sales receipt) to the Service Dealer. The dealer will diagnose the problem and determine if it is covered under warranty.
3. If for any reason you are dissatisfied with the Service Dealer's analysis or with the assistance provided, contact us at:

RLC Customer Care Department
Toro Warranty Company
8111 Lyndale Avenue South
Bloomington, MN 55420-1196
888-865-5676 (U.S. Customers)
888-865-5691 (Canada customers)

Owner Responsibilities

You must maintain your Toro Product by following the maintenance procedures described in the *Operator's Manual*. Such routine maintenance, whether performed by a dealer or by you, is at your expense.

Items and Conditions Not Covered

There is no other express warranty except for special emission system coverage and engine warranty coverage on some products. This express warranty does not cover the following:

- Cost of regular maintenance service or parts, such as filters, fuel, lubricants, oil changes, spark plugs, air filters blade sharpening or worn blades, cable/linkage adjustments, or brake and clutch adjustments
- Components failing due to normal wear
- Any product or part which has been altered or misused or neglected and requires replacement or repair due to accidents or lack of proper maintenance
- Pickup and delivery charges
- Repairs or attempted repairs by anyone other than an Authorized Toro Service Dealer
- Repairs necessary due to failure to follow recommended fuel procedure (consult *Operator's Manual* for more details)
 - Removing contaminants from the fuel system is not covered
 - Use of old fuel (more than one month old) or fuel which contains more than 10% ethanol or more than 15% MTBE
 - Failure to drain the fuel system prior to any period of non-use over one month

General Conditions

All repairs covered by these warranties must be performed by an Authorized Toro Service Dealer using Toro approved replacement parts.

Neither The Toro Company nor Toro Warranty Company is liable for indirect, incidental or consequential damages in connection with the use of the Toro Products covered by this warranty, including any cost or expense of providing substitute equipment or service during reasonable periods of malfunction or non-use pending completion of repairs under this warranty.

All implied warranties of merchantability (that the product is fit for ordinary use) and fitness for use (that the product is fit for a particular purpose) are limited to the duration of the express warranty.

Some states do not allow exclusions of incidental or consequential damages, or limitations on how long an implied warranty lasts, so the above exclusions and limitations may not apply to you.

This warranty gives you specific legal rights, and you may also have other rights which vary from state to state.

Countries Other than the United States or Canada

Customers who have purchased Toro products outside the United States or Canada should contact their Toro Distributor (Dealer) to obtain guarantee policies for your country, province, or state. If for any reason you are dissatisfied with your Distributor's service or have difficulty obtaining guarantee information, contact the Toro importer. If all other remedies fail, you may contact us at Toro Warranty Company.

Australian Consumer Law: Australian customers will find details relating to the Australian Consumer Law either inside the box or at your local Toro Dealer. 374-0252 Rev F