



Count on it.

Operator's Manual

**Z Master[®] Professional 6000
Series Riding Mower
with 60in or 72in TURBO FORCE[®] Side
Discharge Mower**

Model No. 74946—Serial No. 315000001 and Up

Model No. 74947—Serial No. 315000001 and Up



⚠ WARNING

CALIFORNIA Proposition 65 Warning

This product contains a chemical or chemicals known to the State of California to cause cancer, birth defects, or reproductive harm.

The engine exhaust from this product contains chemicals known to the State of California to cause cancer, birth defects, or other reproductive harm.

This spark ignition system complies with Canadian ICES-002

Because in some areas there are local, state, or federal regulations requiring that a spark arrester be used on the engine of this machine, a spark arrester is available as an option. If you require a spark arrester, contact your Authorized Toro Dealer.

Genuine Toro spark arresters are approved by the USDA Forestry Service.

Note: It is a violation of California Public Resource Code Section 4442 to use or operate the engine on any forest-covered, brush-covered, or grass-covered land without a spark arrester muffler maintained in working order, or the engine constricted, equipped, and maintained for the prevention of fire. Other states or federal areas may have similar laws.

⚠ WARNING

Removing standard original equipment parts and accessories may alter the warranty, traction, and safety of the machine. Failure to use original Toro parts could cause serious injury or death. Making unauthorized changes to the engine, fuel or venting system, may violate EPA and CARB regulations.

Replace all parts including, but not limited to, tires, belts, blades, and fuel system components with original Toro parts.

The enclosed *Engine Owner's Manual* is supplied for information regarding the US Environmental Protection Agency (EPA) and the California Emission Control Regulation of emission systems, maintenance, and warranty. Replacements may be ordered through the engine manufacturer.

Introduction

This rotary-blade, riding lawn mower is intended to be used by residential homeowners or professional, hired operators. It is designed primarily for cutting grass on well-maintained lawns on residential or commercial properties. It is not designed for cutting brush or for agricultural uses.

Read this information carefully to learn how to operate and maintain your product properly and to avoid injury and product damage. You are responsible for operating the product properly and safely.

You may contact Toro directly at www.Toro.com for product safety and operation training materials, accessory information, help finding a dealer, or to register your product.

Whenever you need service, genuine Toro parts, or additional information, contact an Authorized Service Dealer or Toro Customer Service and have the model and serial numbers of your product ready. [Figure 1](#) identifies the location of the model and serial numbers on the product. Write the numbers in the space provided.

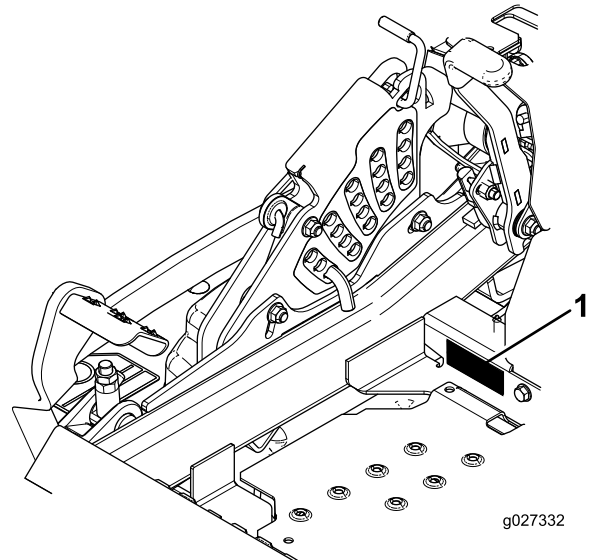

Figure 1

1. Model and serial number location

Model No. _____

Serial No. _____

This manual identifies potential hazards and has safety messages identified by the safety alert symbol (Figure 2), which signals a hazard that may cause serious injury or death if you do not follow the recommended precautions.



Figure 2

1. Safety alert symbol

This manual uses 2 words to highlight information.

Important calls attention to special mechanical information and **Note** emphasizes general information worthy of special attention.

Contents

Safety	4
Safe Operating Practices	4
Toro Mower Safety	6
Slope Indicator	8
Safety and Instructional Decals	9
Product Overview	15
Controls	15
Specifications	17
Operation	17
Adding Fuel.....	17
Checking the Engine-Oil Level.....	18
Breaking in a New Machine.....	19
Using the Rollover Protection System (ROPS)	19
Think Safety First.....	20
Operating the Parking Brake	20
Operating the Mower Blade-Control Switch (PTO)	21
Operating the Throttle with Horizon™ Technology.....	21
Operating the Ignition Switch	22
Using the Fuel-Shutoff Valve	22
Starting and Stopping the Engine.....	22
Using the Safety-Interlock System.....	23
Driving Forward or Backward	24
Stopping the Machine	25
Adjusting the Height-of-Cut	25
Adjusting the Anti-Scalp Rollers	26
Adjusting the Flow Baffle Cam Locks.....	27
Positioning the Flow Baffle.....	28
Positioning the Seat	28
Unlatching the Seat.....	29
Changing the Seat Suspension	29
Using the Drive-Wheel-Release Valves.....	29
Using the Side Discharge	30
Transporting the Machine.....	30
Loading the Machine	31
Operating Tips	32
Maintenance	33

Recommended Maintenance Schedule(s)	33
Lubrication	34
Adding Light Oil or Spray Lubrication	34
Greasing the Mower	34
Lubricating the Caster-Wheel Hubs.....	35
Engine Maintenance	36
Servicing the Air Cleaner	36
Servicing the Engine Oil.....	37
Servicing the Spark Plug.....	40
Checking the Spark Arrester (if equipped)	41
Fuel System Maintenance	42
Servicing the Electronic Fuel-Injection System	42
Replacing the Low-Pressure Fuel Filter.....	42
Servicing the High-Pressure Fuel Filter.....	42
Servicing the Fuel Tank.....	42
Electrical System Maintenance	43
Servicing the Battery.....	43
Servicing the Fuses	44
Drive System Maintenance	45
Checking the Seat Belt.....	45
Checking the Rollover Protection System (ROPS) Knobs.....	45
Adjusting the Tracking	45
Checking the Tire Pressure	46
Checking the Wheel Lug Nuts	46
Checking the Wheel Hub Slotted Nut.....	46
Adjusting the Caster-Pivot Bearing.....	46
Using the Clutch Shim	47
Cooling System Maintenance	49
Servicing the Engine-Oil Cooler	49
Cleaning the Engine Screen.....	49
Cleaning the Engine-Cooling Fins and Shrouds.....	49
Checking and Cleaning the Hydraulic-Unit Shrouds.....	50
Brake Maintenance	51
Adjusting the Parking Brake	51
Belt Maintenance	52
Inspecting the Belts	52
Replacing the Mower Belt.....	52
Replacing the Hydraulic Pump-Drive Belt	53
Controls System Maintenance	54
Adjusting the Control-Handle Position.....	54
Adjusting the Motion-Control Linkage	54
Adjusting the Motion-Control Damper	55
Adjusting the Motion Control Neutral-Lock Pivot.....	56
Hydraulic System Maintenance	56
Servicing the Hydraulic System.....	56
Mower Deck Maintenance.....	58
Leveling the Mower Deck.....	58
Servicing the Cutting Blades.....	61
Removing the Mower Deck	63
Replacing the Grass Deflector.....	64
Cleaning	65
Cleaning under the Mower.....	65
Disposing of Waste.....	65

Storage	65
Cleaning and Storing the Machine	65
Troubleshooting	67
Schematics	70

Safety

Improper use or maintenance by the operator or owner can result in injury. To reduce the potential for injury, comply with these safety instructions, and pay attention to the safety alert symbol, which means **Caution, Warning, or Danger**—“personal safety instruction.” **Failure to comply with the instructions may result in personal injury or death.**

Important: This machine was manufactured according to the appropriate regulatory standards in effect at the time of manufacture. **Modifying this machine in any way may cause it to be out of compliance with those standards and with the instructions in this *Operator’s Manual*. Modifications to this machine should only be made by either the manufacturer or an Authorized Toro Dealer.**

This product is capable of amputating hands and feet. Follow all safety instructions to avoid serious injury or death.

The owner/user can prevent and is responsible for accidents or injuries occurring to people, or damage to property.

Important: The addition of attachments made by other manufacturers that do not meet American National Standards Institute certification will cause noncompliance of this machine.

Safe Operating Practices

The following instructions are adapted from ANSI standard B71.4-2012.

Training

- Read the *Operator’s Manual* and other training material.
 - Note:** If the operator(s) or mechanic(s) cannot read the manual language, it is the owner’s responsibility to explain this material to them.
- Become familiar with the safe operation of the equipment, operator controls, and safety signs.
- All operators and mechanics should be trained. The owner is responsible for training the users.
- Never let children or untrained people operate or service the equipment. Local regulations may restrict the age of the operator.
- The owner/user can prevent and is responsible for accidents or injuries occurring to people, or damage to property.

Preparation

- Evaluate the terrain to determine what accessories and attachments are needed to properly and safely perform the job.
Note: Only use accessories and attachments approved by the manufacturer.
- Wear appropriate clothing including: a hard hat, safety glasses, and hearing protection. Long hair, loose clothing or jewelry may get tangled in moving parts.
- Inspect the area where the equipment is used, and remove all objects that can be thrown by the machine.
- Check that operator's presence controls, safety switches and shields are attached and functioning properly. Do not operate unless they are functioning properly.

Operation

- Lightning can cause severe injury or death. If lightning is seen, or thunder is heard in the area, do not operate the machine; seek shelter.
- Do not run an engine in an enclosed area.
- Only operate in well-lit areas, keeping away from holes and hidden hazards.
- Ensure that all drives are in neutral and that the parking brake is engaged before starting engine. Only start the engine from the operator's position.
- Make sure that you have good footing while using this machine, especially when backing up.
Note: Reduced footing could cause slipping.
- Slow down and use extra care on hillsides. Be sure to travel side to side on hillsides. Turf conditions can affect the stability of the machine. Use caution while operating near drop-offs.
- Slow down and use caution when making turns and when changing directions on slopes.
- Do not raise the mower deck with the blades running.
- Do not operate the machine without the PTO shield or other guards securely in place. Be sure all interlocks are attached, adjusted properly, and functioning properly.
- Do not operate with the discharge deflector raised, removed or altered, unless using a grass catcher.
- Do not change the engine governor setting or overspeed the engine.
- Stop on level ground, disengage drives, engage the parking brake (if provided), shut off the engine before leaving the operator's position for any reason, including emptying the catchers or unclogging the chute.
- Stop equipment and inspect the blades after striking objects or if an abnormal vibration occurs. Make the necessary repairs before resuming operations.
- Keep your hands and feet away from the cutting unit.

- Look behind and down before backing up to ensure a clear path.
- Keep pets and bystanders away from an operating machine.
- Do not carry passengers.
- Slow down and use caution when making turns and crossing roads and sidewalks. Stop the blades if you are not mowing.
- Be aware of the mower-discharge direction and do not point it at anyone.
- Do not operate the mower under the influence of alcohol or drugs.
- Use care when loading or unloading the machine into or from a trailer or truck.
- Use care when approaching blind corners, shrubs, trees, or other objects that may obscure vision.

Safe Handling of Fuels

- To avoid personal injury or property damage, use extreme care in handling gasoline. Gasoline is extremely flammable and the vapors are explosive.
- Extinguish all cigarettes, cigars, pipes, and other sources of ignition.
- Use only an approved fuel container.
- Do not remove the fuel cap or add fuel with the engine running.
- Allow the engine to cool before fueling.
- Do not refuel the machine indoors.
- Do not store the machine or fuel container where there is an open flame, spark, or pilot light such as on a water heater or on other appliances.
- Do not fill containers inside a vehicle, on a truck, or on a trailer bed with a plastic liner. Always place containers on the ground away from your vehicle before filling.
- Remove equipment from the truck or trailer and fuel it on the ground. If this is not possible, then add fuel with such equipment as a portable container, rather than from a fuel dispenser nozzle.
- Keep the nozzle in contact with the rim of the fuel tank or container opening at all times until fueling is complete.
- Do not use a nozzle lock open device.
- If fuel is spilled on clothing, change your clothing immediately.
- Do not overfill fuel tank. Replace fuel cap and tighten securely.

Maintenance and Storage

- Disengage drives, set the parking brake, stop the engine, and remove the key or disconnect spark-plug wire. Wait for all movement to stop before adjusting, cleaning, or repairing.
- Park the machine on a level surface.
- Clean grass and debris from the cutting unit, drives, mufflers, and engine to help prevent fires.
- Clean up oil or fuel spillage.
- Let the engine cool before storing.
- Do not store fuel near flames or drain indoors.
- Do not allow untrained personnel to service machine.
- Use jack stands to support components when required.
- Carefully release pressure from components with stored energy.
- Disconnect the battery or remove the spark-plug wire before making any repairs. Disconnect the negative terminal first and the positive terminal last. Reconnect the positive first and negative last.
- Use care when checking the blades. Wrap the blade(s) or wear thickly padded gloves, and use caution when servicing them. Only replace blades; do not straighten or weld them.
- Keep hands and feet away from moving parts. If possible, do not make adjustments with the engine running.
- Keep all parts in good working condition and all hardware tightened. Replace all worn or damaged decals.

Hauling

- Use care when loading or unloading the machine into a trailer or a truck.
- Use full-width ramps for loading machine into a trailer or a truck.
- Tie the machine down securely using straps, chains, cable, or ropes. Both front and rear straps should be directed down and outward from the machine.

Toro Mower Safety

The following list contains safety information specific to Toro products and other safety information you must know.

This product is capable of amputating hands and feet, and throwing objects. Always follow all safety instructions to avoid serious injury or death.

This product is designed for cutting and recycling grass, or, when equipped with a grass bagger, for catching cut grass. Any use for purposes other than these could prove dangerous to the user and bystanders.

General Operation

- Be sure that the area is clear of bystanders before mowing. Stop the machine if anyone enters the area.
- Do not touch equipment or attachment parts which may be hot from operation. Allow all of the parts to cool before attempting to maintain, adjust, or service the machine.
- Use only Toro-approved attachments. Warranty may be voided if used with any unapproved attachments.
- Check carefully for overhead clearances (i.e. branches, doorways, electrical wires, etc.) before operating under any objects, and do not contact them.
- Slow down before making turns and use extra caution.
- Use caution when riding the platform over curbs, rocks, roots, or other obstructions.
- Look behind and down before backing up to ensure a clear path. Use extra care when operating in reverse.
- Do not jerk the controls; use a steady motion.
- When loading or unloading the machine, use one full-width ramp that is wide enough to extend beyond the width of the machine.
- Do not carry passengers.
- Do not carry equipment on the machine.

Slope Operation

All slopes and ramps require extra caution. If you feel uneasy on a slope, do not mow it.

- Remove obstacles such as rocks, tree limbs, etc. from the mowing area.
- Watch for holes, ruts or bumps.
- **Note:** Tall grass can hide obstacles.
- Use caution near drop-offs, ditches, or embankments.
- **Note:** The machine could suddenly turn over if a wheel goes over the edge of a cliff or ditch, or if an edge caves in.
- Use extra care with grass catchers or other attachments.
- **Note:** These can change the stability of the machine.
- Keep all movement on slopes slow and gradual.
- Do not make sudden changes in speed or direction.
- Mow slopes side to side.
- Do not mow slopes greater than 15 degrees.

Using the Rollover Protection System (ROPS)

- The ROPS is an integral and effective safety device. Keep the ROPS in the raised and locked position and use the seat belt when operating the machine.
- Lower the ROPS temporarily only when absolutely necessary. Do not wear the seat belt when the ROPS is folded down.
- Be aware there is no rollover protection when the ROPS is in the down position.
- Be certain that the seat belt can be released quickly in the event of an emergency.
- Check the area to be mowed and never fold down the ROPS in areas where there are slopes, drop offs or water.
- Check carefully for overhead clearances (i.e. branches, doorways, electrical wires) before driving under any objects and do not contact them.
- Keep the ROPS in safe operating condition by periodically thoroughly inspecting for damage and keeping all mounting fasteners tight.
- Replace a damaged ROPS. Do not repair or revise.
- **Do not** remove the ROPS.
- Any alterations to a ROPS must be approved by the manufacturer.

Service

- Do not store the machine or a fuel container inside where there is an open flame, such as near a water heater or furnace.
- Keep the nuts and bolts tight, especially the blade-attachment bolts.
- Never interfere with the intended function of a safety device or reduce the protection provided by a safety device. Check their proper operation regularly.
- To best protect your investment and maintain optimal performance of your Toro equipment, count on Toro genuine parts. When it comes to reliability, Toro delivers replacement parts designed to the exact engineering specifications of our equipment. For peace of mind, insist on Toro genuine parts.
- Check brake operation frequently. Adjust and service as required.

Slope Indicator

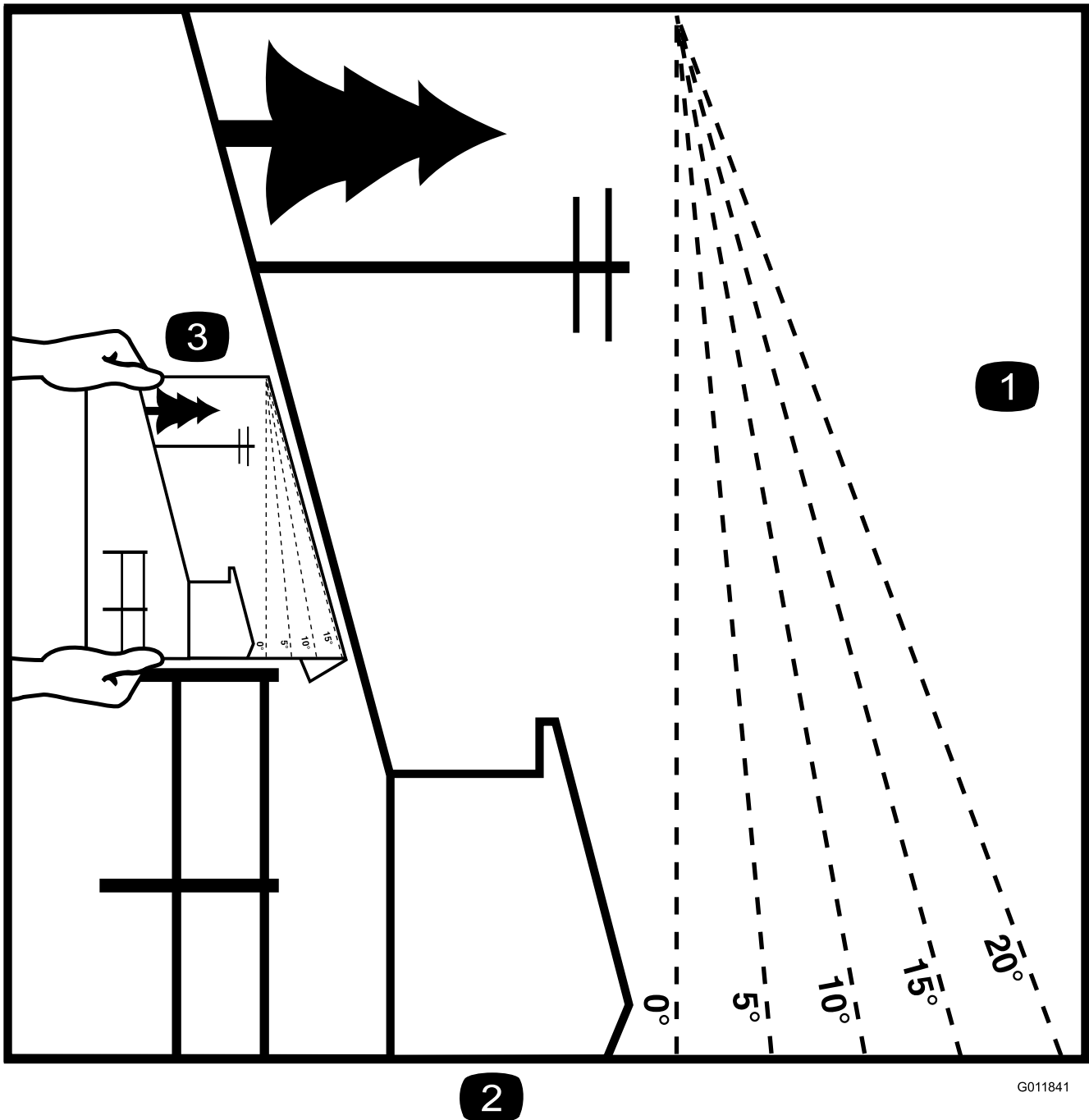

G011841

2

Figure 3

This page may be copied for personal use.

1. The maximum slope you can safely operate the machine on is **15 degrees**. Use the slope chart to determine the degree of slope of hills before operating. **Do not operate this machine on a slope greater than 15 degrees**. Fold along the appropriate line to match the recommended slope.
2. Align this edge with a vertical surface, a tree, building, fence pole, etc.
3. Example of how to compare slope with folded edge.

Safety and Instructional Decals



Safety decals and instructions are easily visible to the operator and are located near any area of potential danger. Replace any decal that is damaged or lost.



1
58-6520

- Grease

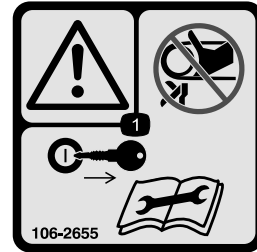

106-2655

- Warning—do not touch or approach moving belts; remove the ignition key and read the instructions before servicing or performing maintenance.

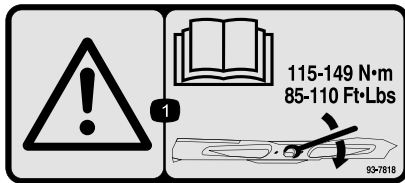

93-7818

- Warning—read the *Operator's Manual* for instructions on torquing the blade bolt/nut to 115-149 N·m (85-110 ft-lb).

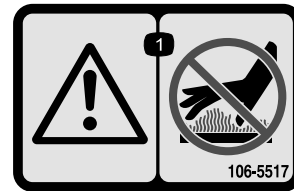

106-5517

- Warning—Do Not touch the hot surface.

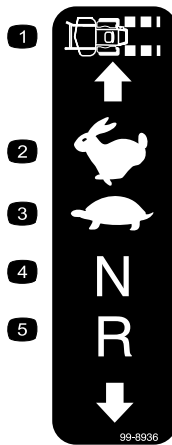

99-8936

- | | |
|------------------|------------|
| 1. Machine speed | 4. Neutral |
| 2. Fast | 5. Reverse |
| 3. Slow | |

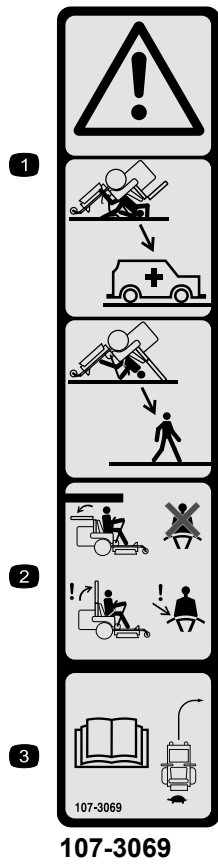

107-3069

1. Warning—there is no rollover protection when the roll bar is down.
2. To avoid injury or death from a rollover accident, keep the roll bar in the fully raised and locked position and wear the seat belt. Lower the roll bar only when absolutely necessary; do not wear the the seat belt when the roll bar is down.
3. Read the *Operator's Manual*; drive slowly and carefully.

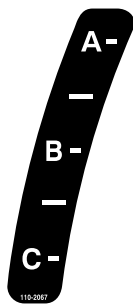

110-2067

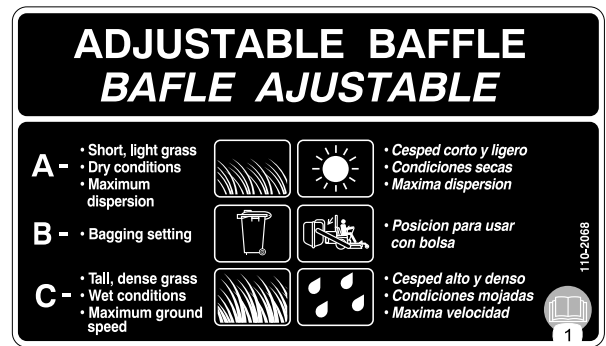

110-2068

1. Read the *Operator's Manual*.

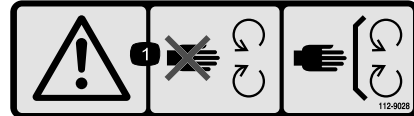

112-9028

1. Warning—stay away from moving parts; keep all guards in place.

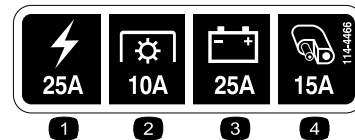

114-4466

1. Main, 25A
2. PTO, 10A
3. Charge, 25A
4. Auxiliary, 15A

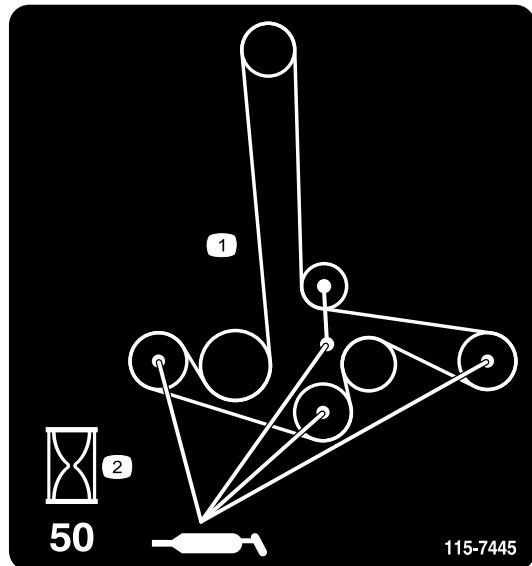

115-7445

1. Grease pulleys and spindles
2. Maintenance interval—50 hours

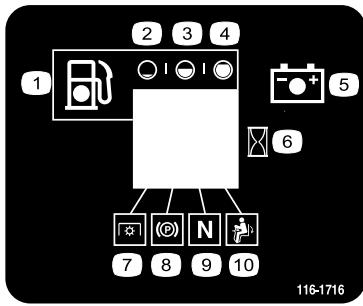

116-1716

- | | |
|------------|------------------------------|
| 1. Fuel | 6. Hour meter |
| 2. Empty | 7. PTO |
| 3. Half | 8. Parking brake |
| 4. Full | 9. Neutral |
| 5. Battery | 10. Operator presence switch |

CALIFORNIA SPARK ARRESTER WARNING

Operation of this equipment may create sparks that can start fires around dry vegetation. A spark arrester may be required. The operator should contact local fire agencies for laws or regulations relating to fire prevention requirements.

116-4858

116-4858

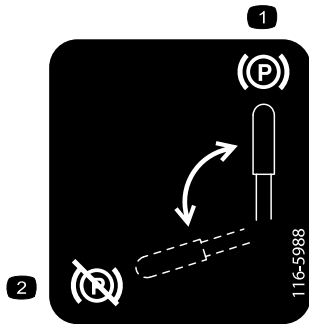

116-5988

- | | |
|--------------------------|-----------------------------|
| 1. Parking brake—engaged | 2. Parking brake—disengaged |
|--------------------------|-----------------------------|



116-8726

1. Read the *Operator's Manual* for recommended hydro oil.

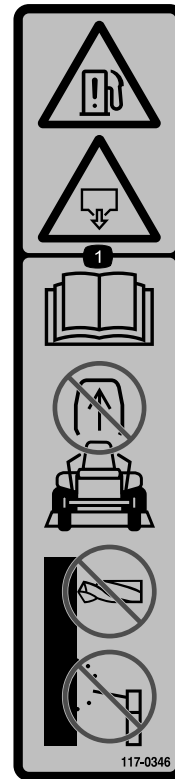

117-0346

1. Fuel leak hazard—read the *Operator's Manual*; do not attempt to remove the roll bar; do not weld, drill or modify the roll bar in any way.



117-3848

1. Thrown object hazard—keep bystanders a safe distance from the machine
2. Thrown object hazard, mower—do not operate without the deflector, discharge cover or grass collection system in place.
3. Cutting/dismemberment of hand or foot—stay away from moving parts; keep all guards and shields in place.

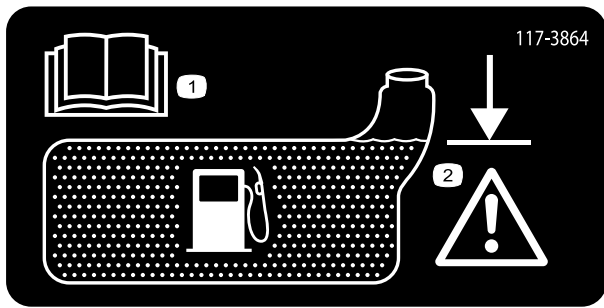

117-3864

1. Read the *Operator's Manual*.
2. Fill to bottom of filler neck; warning—do not overfill the tank.



Battery Symbols

Some or all of these symbols are on your battery

1. Explosion hazard
2. No fire, open flame, or smoking.
3. Caustic liquid/chemical burn hazard
4. Wear eye protection
5. Read the *Operator's Manual*.
6. Keep bystanders a safe distance from the battery.
7. Wear eye protection; explosive gases can cause blindness and other injuries
8. Battery acid can cause blindness or severe burns.
9. Flush eyes immediately with water and get medical help fast.
10. Contains lead; do not discard.



Manufacturer's Mark

1. Indicates the blade is identified as a part from the original machine manufacturer.

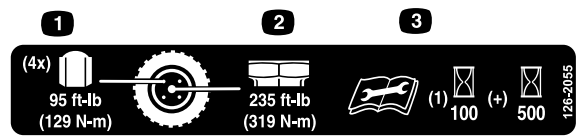

126-2055

1. Wheel lug nut torque 95 ft-lb (129 N-m) (4x)
2. Wheel hub nut torque 235 ft-lb (319 N-m)
3. Read and understand the *Operator's Manual* before performing any maintenance, check torque after first 100 hours then every 500 hours thereafter.

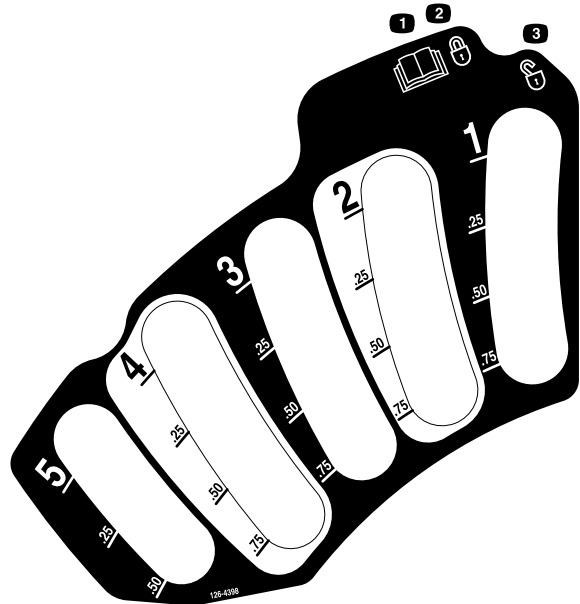

126-4398

1. Read the *Operator's Manual*
2. Lock
3. Unlock

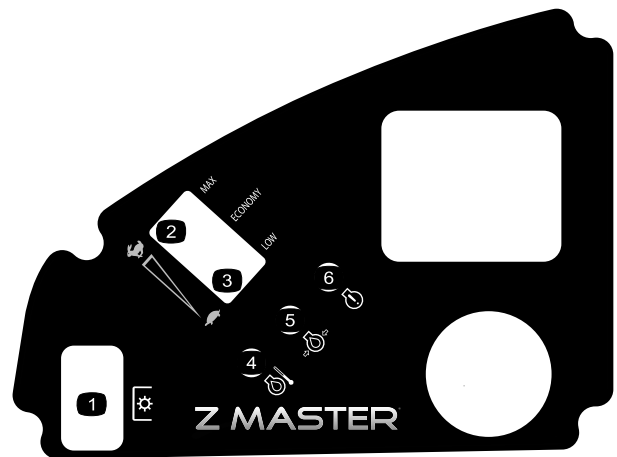

127-0314

1. PTO switch
2. Maximum speed
3. Low speed
4. High oil-temperature indicator
5. Low oil-pressure indicator
6. Malfunction-indicator light (MIL)

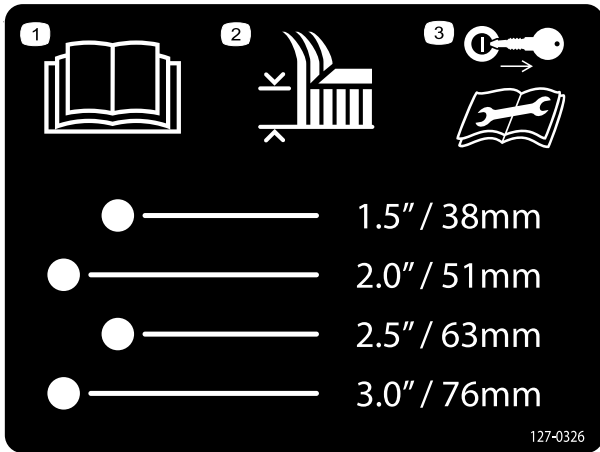

127-0326

1. Read the *Operator's Manual*.
2. Height-of-cut
3. Remove the key from the ignition and read the *Operator's Manual* before performing maintenance or servicing the machine.

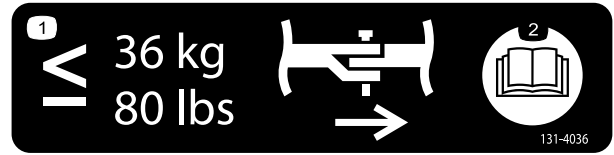

131-4036

1. Maximum drawbar pull 36 kg (80 lb)
2. Read the *Operator's Manual*.

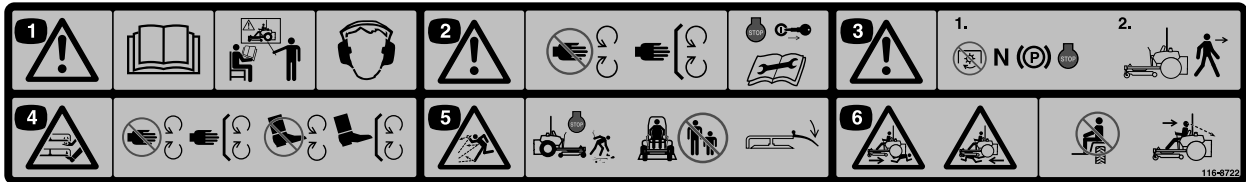

116-8722

1. Warning—Read the *Operator's Manual*. Do not operate this machine unless you are trained. Wear hearing protection.
2. Warning—Stay away from moving parts; keep all guards in place. Stop engine and remove key before adjusting, servicing, or cleaning.
3. Warning—Disengage PTO, move drive levers out to neutral lock position, engage parking brake, and stop engine before leaving the operator's position.
4. Cutting/dismemberment of hand or foot—stay away from moving parts; keep all guards and shields in place.
5. Thrown object hazard—Pick up objects that could be thrown by mower. Do Not operate when people and pets are in the area. Keep deflector in place.
6. Crushing/dismemberment hazard of bystanders—do not carry passengers, look forward and down when operating the machine, look behind and down when reversing.

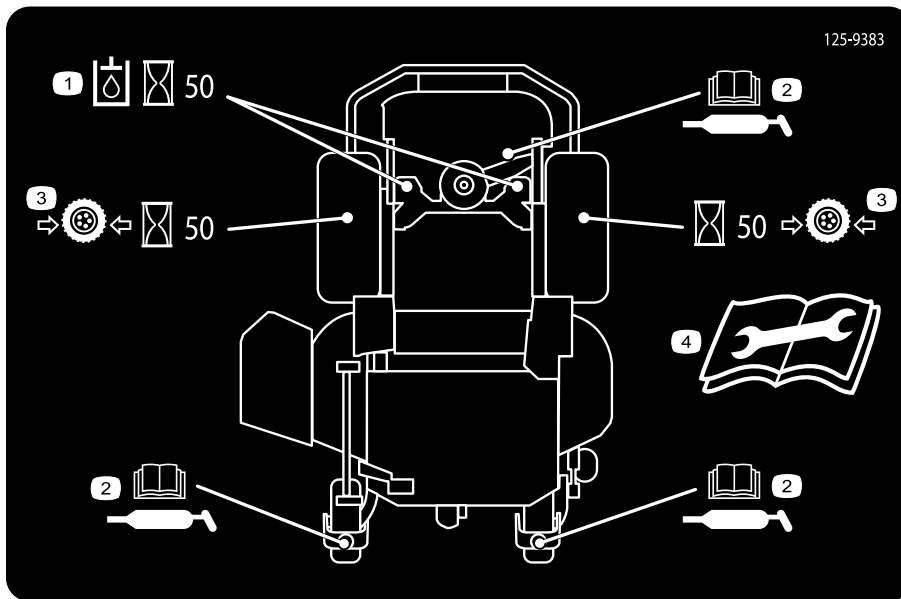

125-9383

1. Check hydraulic oil every 50 operating hours.
2. Read the *Operator's Manual* for information on lubricating the machine.
3. Check the tire pressure every 50 operating hours.
4. Read the *Operator's Manual* before servicing or performing maintenance.

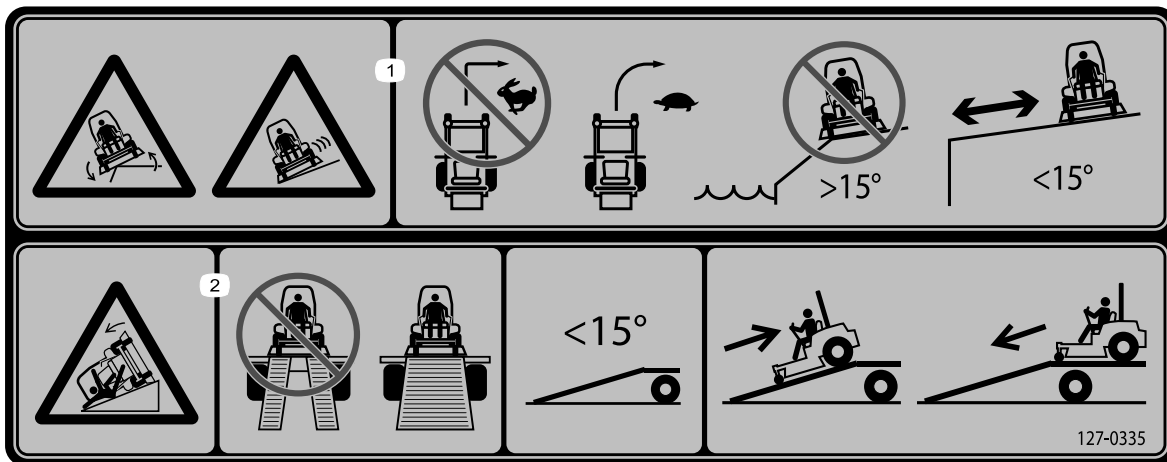

127-0335

1. Tipping hazard on slopes—do not use this machine on slopes greater than 15 degrees; do not make sudden, tight turns; make slow, wide turns.
2. Ramp hazard—when loading onto a trailer, do not use dual ramps; only use a singular ramp wide enough for the machine; back up the ramp (in reverse) and drive forward off the ramp.

Product Overview

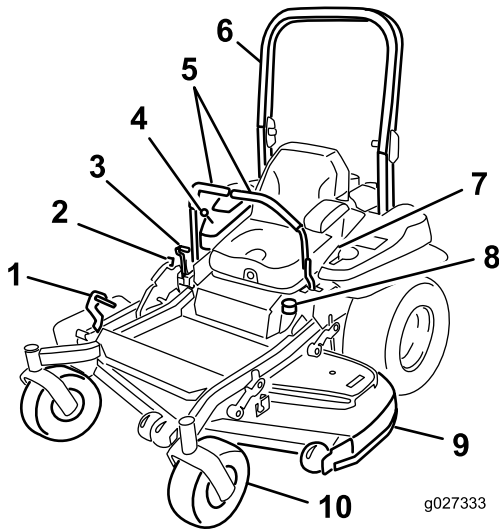

Figure 4

- | | |
|----------------------------------|------------------|
| 1. Height-of-cut deck-lift pedal | 6. Roll bar |
| 2. Transport lock | 7. Seat belt |
| 3. Parking-brake lever | 8. Fuel cap |
| 4. Controls | 9. Mower deck |
| 5. Motion-control levers | 10. Caster wheel |

Controls

Become familiar with all the controls before you start the engine and operate the machine (Figure 4 and Figure 5).

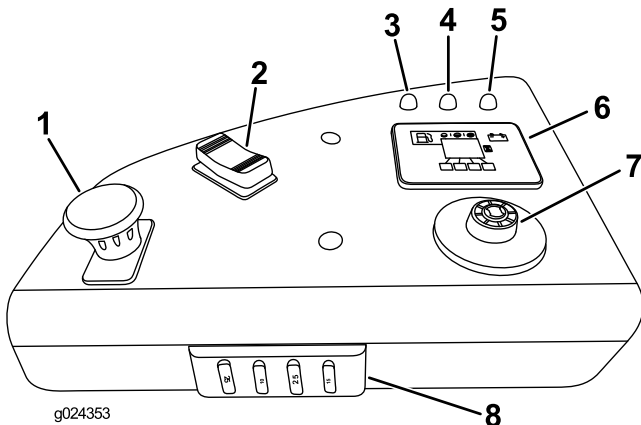

Figure 5

- | | |
|-----------------------------------|---|
| 1. PTO switch | 5. Malfunction-indicator light (MIL) |
| 2. Throttle switch | 6. Hour meter/Safety-interlock display/Fuel gauge |
| 3. High oil-temperature indicator | 7. Ignition switch |
| 4. Low oil-pressure indicator | 8. Fuses |

Hour Meter

The hour meter records the number of hours the engine has operated. It operates when the engine is running. Use these times for scheduling regular maintenance (Figure 6).

Fuel Gauge

The fuel gauge is located with the hour meter, and the bars light up when the ignition switch is in the On position (Figure 6).

The indicator light appears when the fuel level is low (approximately one gallon remaining in the fuel tank).

Safety-Interlock Indicators

There are symbols on the hour meter that indicate with a black triangle that the interlock component is in the correct position (Figure 6).

Battery-Indicator Light

If the ignition key is turned to the **On** position for a few seconds, the battery voltage will be displayed in the area where the hours are normally displayed.

The battery light turns on when the ignition is turned on and when the charge is below the correct operating level (Figure 6).

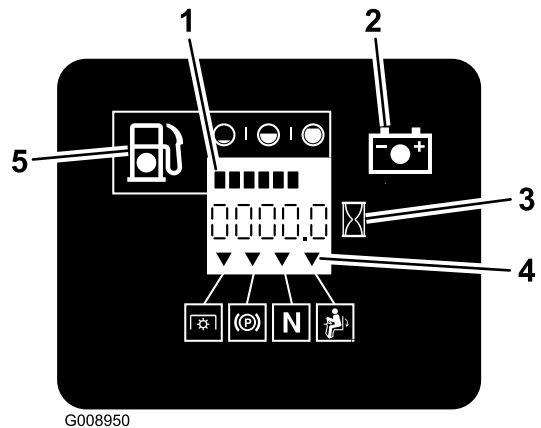

Figure 6

- | | |
|----------------------|-----------------------------|
| 1. Fuel gauge (bars) | 4. Safety-interlock symbols |
| 2. Battery light | 5. Low fuel-indicator light |
| 3. Hour meter | |

Throttle Control

There are 3 speed positions: **maximum speed**, **economy speed**, and **low speed**.

Blade-Control Switch (PTO)

The blade-control switch (PTO) is used to engage the electric clutch and drive the mower blades. Pull the switch up to engage the blades and release. To disengage the blades, push the blade-control switch (PTO) down or move a motion-control lever into the neutral-lock position.

Ignition Switch

This switch is used to start the mower engine and has 3 positions: **Start**, **Run**, and **Off**.

Motion-Control Levers

The motion-control levers are used to drive the machine forward, reverse, and turn either direction.

Neutral-Lock Position

The neutral-lock position is used with the safety-interlock system to engage and to determine neutral position.

Fuel-Shutoff Valve

Close the fuel-shutoff valve (under the seat) when transporting or storing the mower.

High-Oil Temperature Indicator Light

This is the malfunction-indicator light found on the left side (Figure 5).

If the engine-oil temperature rises above the safe level, the light illuminates, the engine automatically reduces the rpm, and the machine will remain in a safe mode until the corrective action is taken; refer to (page).

Low-Oil Pressure Indicator Light

This is the middle malfunction-indicator light (Figure 5).

If the engine-oil pressure drops below a safe level, this light illuminates, the engine automatically reduces the rpm, and the machine will remain in a safe mode until the corrective action is taken; refer to (page).

Electronic-Control Unit Malfunction-Indicator Light

The electronic-control unit (ECU) continuously monitors the operation of the EFI system.

If a problem or fault within the system is detected, the malfunction indicator light (MIL) is illuminated.

The MIL is found on the right side of the control panel (Figure 5).

Once the MIL illuminates, initial trouble shooting checks should be made. Refer to the MIL section under (page).

If these checks do not correct the problem, further diagnosis and servicing by an Authorized Service Dealer is necessary.

Attachments/Accessories

A selection of Toro approved attachments and accessories is available for use with the machine to enhance and expand its capabilities. Contact your Authorized Service Dealer or Distributor or go to www.Toro.com for a list of all approved attachments and accessories.

Specifications

Note: Specifications and design are subject to change without notice.

Width:

	60-inch Deck	72-inch Deck
Without Deck	135 cm (53 inches)	150 cm (59 inches)
Deflector Up	157 cm (62 inches)	187 cm (74 inches)
Deflector Down	192 cm (76 inches)	222 cm (88 inches)

Length:

	60-inch Deck	72-inch Deck
Roll Bar - Up	211 cm (83 inches)	219 cm (83 inches)
Roll Bar - Down	215 cm (85 inches)	223 cm (88 inches)

Height:

Roll Bar - Up	Roll Bar - Down
179.1 cm (70.5 inches)	119 cm (47 inches)

Weight:

Model	Weight
74946	576 kg (1269 lb)
74947	612 kg (1349 lb)

Operation

Note: Determine the left and right sides of the machine from the normal operating position.

Adding Fuel

- For best results, use only clean, fresh (less than 30 days old), unleaded gasoline with an octane rating of 87 or higher ((R+M)/2 rating method).
- **Ethanol:** Gasoline with up to 10% ethanol (gasohol) or 15% MTBE (methyl tertiary butyl ether) by volume is acceptable. Ethanol and MTBE are not the same. Gasoline with 15% ethanol (E15) by volume is not approved for use. **Never use gasoline that contains more than 10% ethanol by volume**, such as E15 (contains 15% ethanol), E20 (contains 20% ethanol), or E85 (contains up to 85% ethanol). Using unapproved gasoline may cause performance problems and/or engine damage which may not be covered under warranty.
- **Do not** use gasoline containing methanol.
- **Do not** store fuel either in the fuel tank or fuel containers over the winter unless a fuel stabilizer is used.
- **Do not** add oil to gasoline.

⚠ DANGER

In certain conditions, gasoline is extremely flammable and highly explosive. A fire or explosion from gasoline can burn you and others and can damage property.

- **Fill the fuel tank outdoors, in an open area, when the engine is cold. Wipe up any gasoline that spills.**
- **Never fill the fuel tank inside an enclosed trailer.**
- **Do not fill the fuel tank completely full. Add gasoline to the fuel tank until the level is 6 to 13 mm (1/4 to 1/2 inch) below the bottom of the filler neck. This empty space in the tank allows gasoline to expand.**
- **Never smoke when handling gasoline, and stay away from an open flame or where gasoline fumes may be ignited by a spark.**
- **Store gasoline in an approved container and keep it out of the reach of children. Never buy more than a 30-day supply of gasoline.**
- **Do not operate without entire exhaust system in place and in proper working condition.**

⚠ DANGER

In certain conditions during fueling, static electricity can be released causing a spark which can ignite the gasoline vapors. A fire or explosion from gasoline can burn you and others and can damage property.

- Always place gasoline containers on the ground away from your vehicle before filling.
- Do not fill gasoline containers inside a vehicle or on a truck or trailer bed because interior carpets or plastic truck bed liners may insulate the container and slow the loss of any static charge.
- When practical, remove gas-powered equipment from the truck or trailer and refuel the equipment with its wheels on the ground.
- If this is not possible, then refuel such equipment on a truck or trailer from a portable container, rather than from a gasoline dispenser nozzle.
- If a gasoline dispenser nozzle must be used, keep the nozzle in contact with the rim of the fuel tank or container opening at all times until fueling is complete.

⚠ WARNING

Gasoline is harmful or fatal if swallowed. Long-term exposure to vapors can cause serious injury and illness.

- Avoid prolonged breathing of vapors.
- Keep face away from nozzle and gas tank or conditioner bottle opening.
- Avoid contact with skin; wash off spillage with soap and water.

Using Stabilizer/Conditioner

Use a fuel stabilizer/conditioner in the machine to provide the following benefits:

- Keeps gasoline fresh during storage of 90 days or less. For longer storage it is recommended that the fuel tank be drained.
- Cleans the engine while it runs
- Eliminates gum-like varnish buildup in the fuel system, which causes hard starting

Important: Do not use fuel additives containing methanol or ethanol.

Add the correct amount of gas stabilizer/conditioner to the gas.

Note: A fuel stabilizer/conditioner is most effective when mixed with fresh gasoline. To minimize the chance of varnish deposits in the fuel system, use fuel stabilizer at all times.

Filling the Fuel Tank

Note: Do not fill the fuel tank completely full. Fill the fuel tank to the bottom of the filler neck. The empty space in the tank allows the gasoline to expand.

1. Park the machine on level ground.
2. Shut the engine off and set the parking brake.
3. Clean around the fuel-tank cap.
4. Fill the fuel tank to the bottom of the filler neck (Figure 7).

Note: Ensure that there is empty space in the tank to allow the gasoline to expand

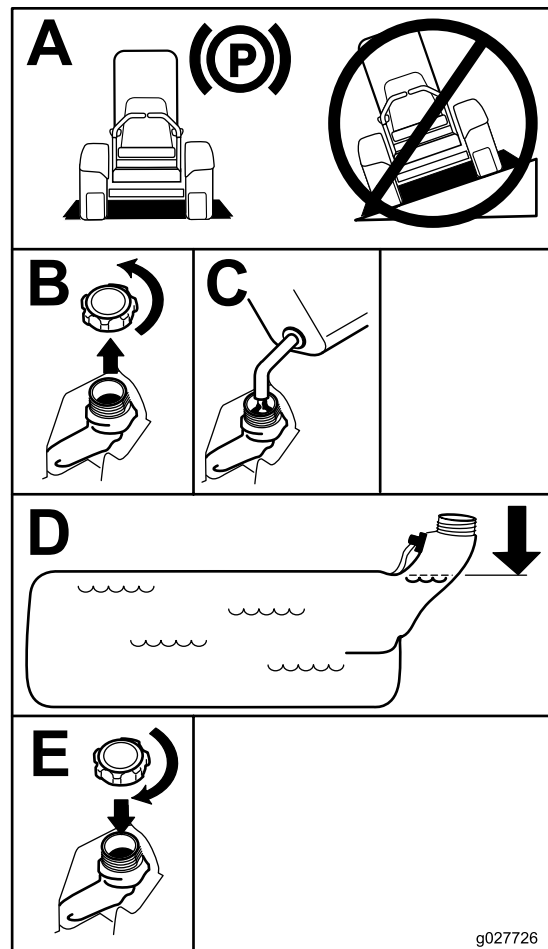

Figure 7

Checking the Engine-Oil Level

Before you start the engine and use the machine, check the oil level in the engine crankcase; refer to [Checking the Engine-Oil Level \(page 38\)](#).

Breaking in a New Machine

New engines take time to develop full power. Mower decks and drive systems have higher friction when they are new, placing additional load on the engine. Allow 40 to 50 hours of break-in time for new machines to develop full power and perform at their best performance.

Using the Rollover Protection System (ROPS)

⚠ WARNING

To avoid injury or death from rollover: keep the roll bar in the fully raised locked position and use the seat belt.

Ensure the seat is secured to the machine.

⚠ WARNING

There is no rollover protection when the roll bar is in the down position.

- Lower the roll bar only when absolutely necessary.
- Do not wear the seat belt when the roll bar is in the down position.
- Drive slowly and carefully.
- Raise the roll bar as soon as clearance permits.
- Check carefully for overhead clearances (i.e. branches, doorways, electrical wires) before driving under any objects and do not contact them.

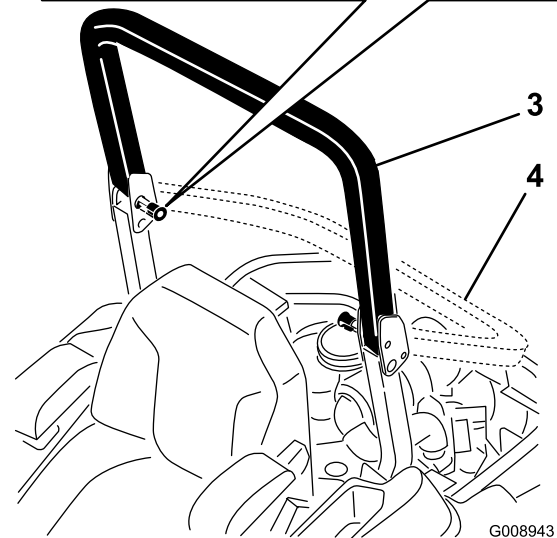
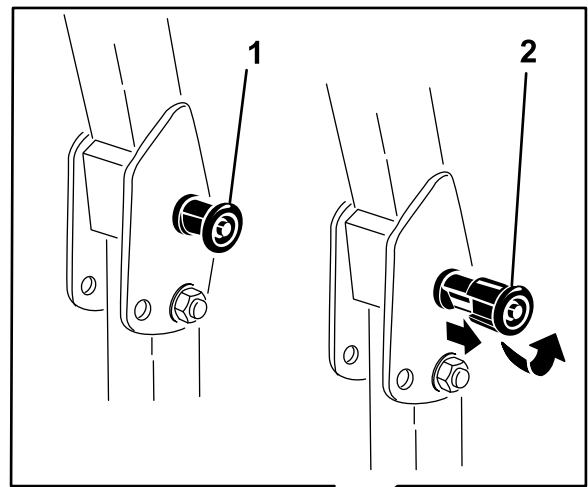

Figure 8

- | | |
|---|-------------------------------------|
| 1. ROPS knob | 3. Roll bar in the upright position |
| 2. Pull ROPS knob out and rotate 90 degrees | 4. Roll bar in the folded position |

1. To lower the roll bar, apply forward pressure to the upper part of the roll bar.
2. Pull both knobs out and rotate them 90° so they are not engaged (Figure 8).
3. Lower the roll bar to the down position (Figure 8).

4. To raise the roll bar, raise the roll bar to the operate position, rotate the knobs so that they move partially into the grooves (Figure 8).
5. Raise the roll bar to the full upright position while pushing on the upper roll bar and the pins will snap into position when the holes align with the pins (Figure 8).

Important: Always use the seat belt with the roll bar in the raised position.

6. Push on the roll bar and ensure that both pins are engaged.

Think Safety First

Please read all safety instructions and symbols in the safety section. Knowing this information could help you or bystanders avoid injury.

⚠ DANGER

Operating on wet grass or steep slopes can cause sliding and loss of control.

Wheels dropping over edges can cause rollovers, which may result in serious injury, death or drowning.

There is no rollover protection when the roll bar is down.

Always keep the roll bar in the fully raised and locked position and use the seat belt.

Read and follow the rollover protection instructions and warnings.

To avoid loss of control and possibility of rollover:

- Do not operate near drop-offs or near water.
- Do not operate on slopes greater than 15 degrees.
- Reduce speed and use extreme caution on slopes.
- Avoid sudden turns or rapid speed changes.

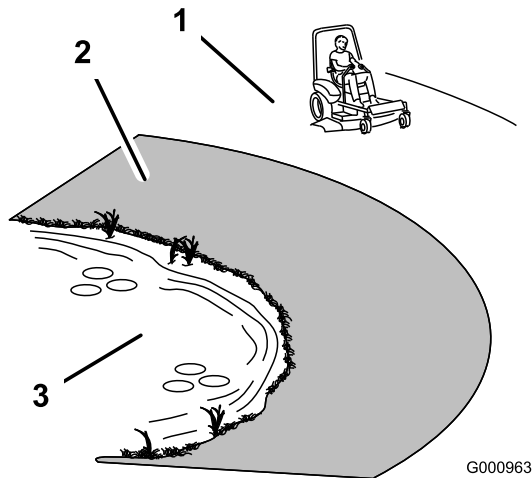

Figure 9

G000963

1. Safe Zone-use the Z Master here on slopes less than 15 degrees or flat areas.
2. Danger Zone- use a walk behind mower and/or a hand trimmer on slopes greater than 15 degrees, near drop-offs and water.
3. Water

⚠ CAUTION

This machine produces sound levels in excess of 85 dBA at the operators ear and can cause hearing loss through extended periods of exposure.

Wear hearing protection when operating this machine.

The use of protective equipment for eyes, ears, hands, feet, and head is recommended.

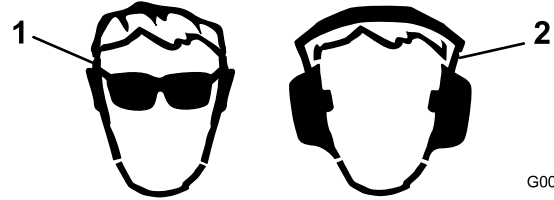

G009027

Figure 10

1. Wear safety glasses
2. Wear hearing protection

Operating the Parking Brake

Always set the parking brake when you stop the machine or leave it unattended.

Setting the Parking Brake

⚠ WARNING

Parking brake may not hold machine parked on a slope and could cause personal injury or property damage.

Do not park on slopes unless wheels are chocked or blocked

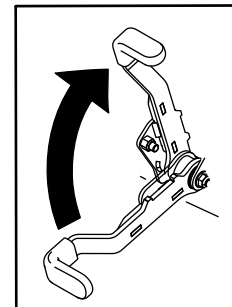

g027334

Figure 11

Releasing the Parking Brake

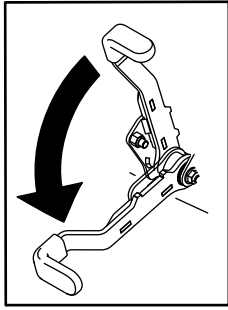

g027335

Figure 12

Operating the Mower Blade-Control Switch (PTO)

The blade-control switch (PTO) starts and stops the mower blades and any powered attachments.

Engaging the Blade-Control Switch (PTO)

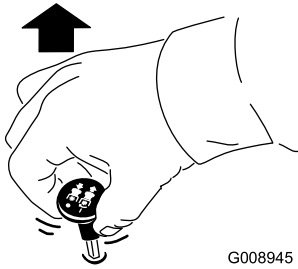

G008945

Figure 13

Disengaging the Blade-Control Switch (PTO)

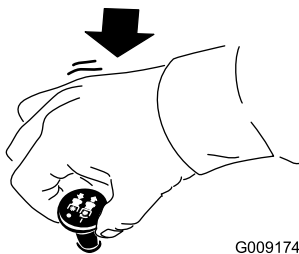

G009174

Figure 14

Operating the Throttle with Horizon™ Technology

There are 3 positions that the throttle switch can operate at—**maximum speed, economy speed, and low speed** (Figure 15).

From the economy speed (middle) position, push down on the front of the switch to place the throttle into the maximum-speed position (Figure 15).

From the economy speed (middle) position, push down on the back of the switch to place the throttle into the low-speed position (Figure 15).

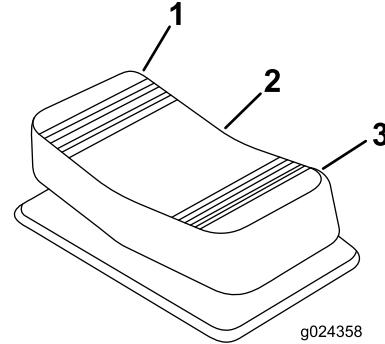

g024358

Figure 15

1. Front position/Maximum speed
2. Middle position/Economy speed
3. Rear position/Low speed

Positioning the throttle switch to maximum, economy, or low allows for 6 different operational modes—3 modes with the PTO disengaged (transport) and 3 modes with the PTO engaged (mow). See the following table to determine the appropriate engine speed.

Throttle-Switch Position	PTO Disengaged (Transport Mode)	PTO Engaged (Mow Mode)
Front position	Maximum transport speed/High idle	Maximum throttle setting—maximum power for extreme mowing conditions
Middle position	Medium transport speed/Clutch engagement	Economy throttle setting—standard power for normal mowing conditions. This is the lowered engine rpm and is the most fuel-efficient mode for mowing.
Rear position	Low transport speed/Low idle	Low throttle setting—reduces the deck packing in wet mowing conditions.

Operating the Ignition Switch

1. Turn the ignition key to the Start position (Figure 16). When the engine starts, release the key.

Important: Do not engage starter for more than 5 seconds at a time. If the engine fails to start allow a 15 second cool-down period between attempts. Failure to follow these instructions can burn out the starter motor.

Note: Additional starting cycles may be required when starting the engine for the first time after the fuel system has been without fuel completely.

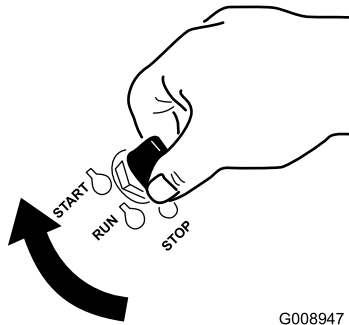

Figure 16

G008947

2. Turn the ignition key to the stop position to stop the engine.

Using the Fuel-Shutoff Valve

The fuel-shutoff valve is located under the seat. Move the seat forward to access it.

Note: Close the fuel-shutoff valve for transport, maintenance, and storage.

Note: Ensure that the fuel-shutoff valve is open when starting the engine.

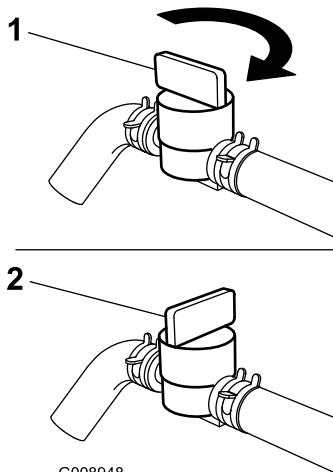

Figure 17

G008948

1. On position
2. Off position

Starting and Stopping the Engine

Starting the Engine

1. Raise the ROPS up and lock into place, sit on the seat, and fasten the seat belt.
2. Move the motion controls to neutral-locked position.
3. Set the parking brake; refer to [Setting the Parking Brake \(page 20\)](#).
4. Move the blade-control switch (PTO) to the Off position (Figure 18).
5. Move the throttle switch to the middle position between the front and rear positions.

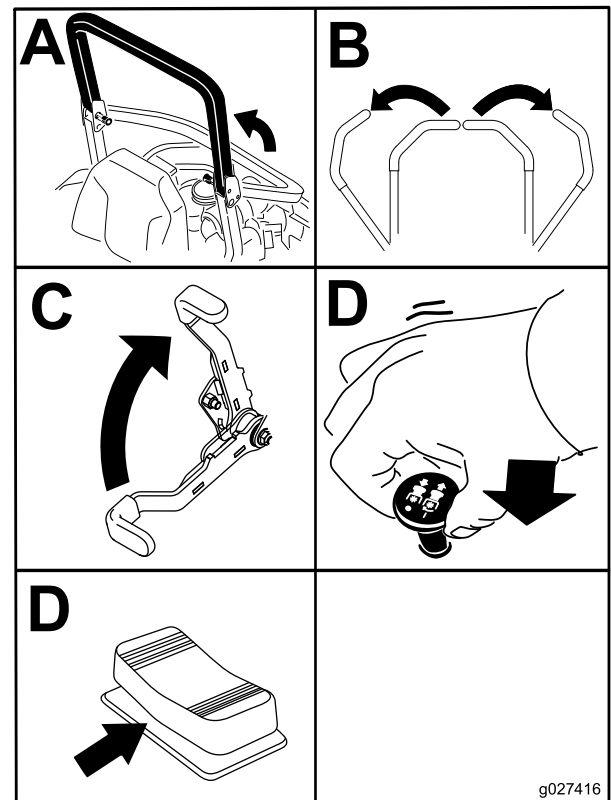

Figure 18

g027416

6. Turn the ignition key to the Start position (Figure 19).

Note: When the engine starts, release the key.

Important: Do not engage starter for more than 5 seconds at a time. If the engine fails to start allow a 15-second cool-down period between attempts. Failure to follow these instructions can burn out the starter motor.

Note: Additional starting cycles may be required when starting the engine for the first time after the fuel system has been without fuel completely.

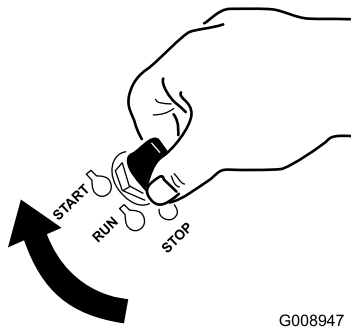

Figure 19

G008947

Stopping the Engine

⚠ CAUTION

Children or bystanders may be injured if they move or attempt to operate the machine while it is unattended.

Always remove the ignition key and set the parking brake when leaving the machine unattended, even if just for a few minutes.

Let the engine idle at slow throttle (in the rear position) for 60 seconds before turning the ignition switch off.

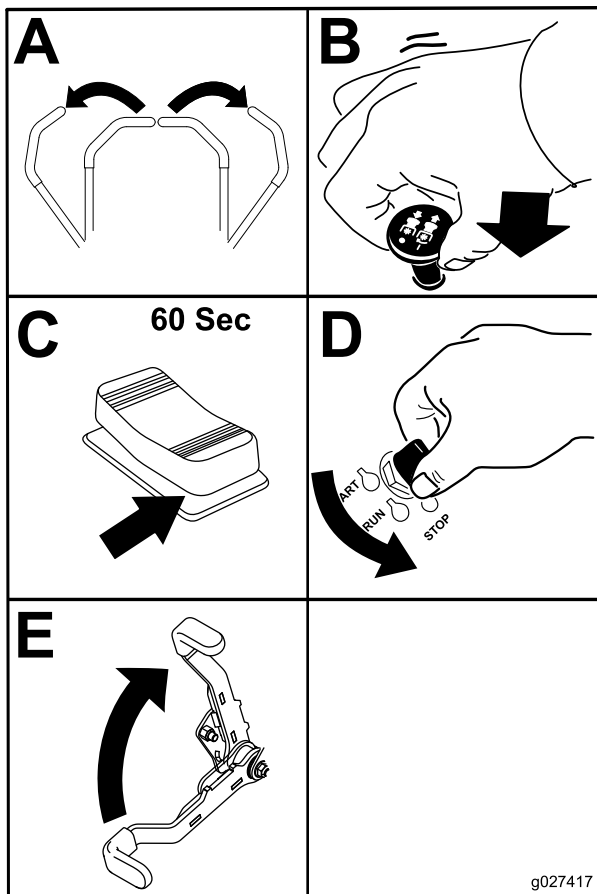

Figure 20

g027417

Important: Make sure that the fuel shut-off valve is closed before transporting or storing the machine, as fuel leakage may occur. Set the parking brake before transporting. Make sure to remove the key as the fuel pump may run and cause the battery to lose charge.

Using the Safety-Interlock System

⚠ CAUTION

If safety-interlock switches are disconnected or damaged the machine could operate unexpectedly causing personal injury.

- Do not tamper with the interlock switches.
- Check the operation of the interlock switches daily and replace any damaged switches before operating the machine.

Understanding the Safety-Interlock System

The safety-interlock system is designed to prevent the engine from starting unless:

- The parking brake is engaged.
- The blade-control switch (PTO) is disengaged.
- The motion-control levers are in the neutral-locked position.

The safety-interlock system also is designed to stop the engine when the traction controls are moved from the locked position with the parking brake engaged or if you rise from the seat when the PTO is engaged.

The hour meter has symbols to notify the user when the interlock component is in the correct position. When the component is in the correct position, a triangle will light up in the corresponding square.

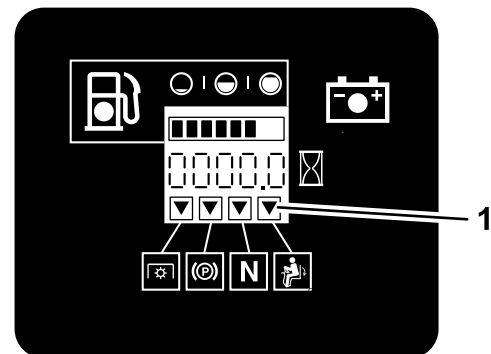

G009181

Figure 21

1. Triangles light up when the interlock components are in the correct position

Testing the Safety-Interlock System

Service Interval: Before each use or daily

Test the safety-interlock system before you use the machine each time. If the safety system does not operate as described below, have an Authorized Service Dealer repair the safety system immediately.

1. Sitting on the seat, engage the parking brake and move the blade-control switch (PTO) to the On position. Try starting the engine; the engine should not crank.
2. Sitting on the seat, engage the parking brake and move the blade-control switch (PTO) to the Off position. Move either motion-control lever (out of neutral locked position). Try starting the engine; the engine should not crank. Repeat for other control lever.
3. Sitting on the seat, engage the parking brake, move the blade-control switch (PTO) to the Off position, and move the motion-control levers to neutral-lock position. Now start the engine. While the engine is running, release the parking brake, engage the blade-control switch (PTO) and rise slightly from the seat; the engine should stop.
4. Sitting on the seat, engage the parking brake, move the blade-control switch (PTO) to the Off position, and move the motion-control levers to neutral-lock position. Now start the engine. While the engine is running, center either motion control and move (forward or reverse); the engine should stop. Repeat for other motion control.
5. Sitting on the seat, disengage the parking brake, move the blade-control switch (PTO) to the Off position, and move the motion-control levers to neutral-lock position. Try starting the engine; the engine should not crank.

Driving Forward or Backward

The throttle control regulates the engine speed as measured in rpm (revolutions per minute). Place the throttle control in the Fast position for best performance. Always operate in the full throttle position when mowing.

CAUTION

Machine can spin very rapidly. Operator may lose control of machine and cause personal injury or damage to machine.

- Use caution when making turns.
- Slow the machine down before making sharp turns.

Using the Motion-Control Levers

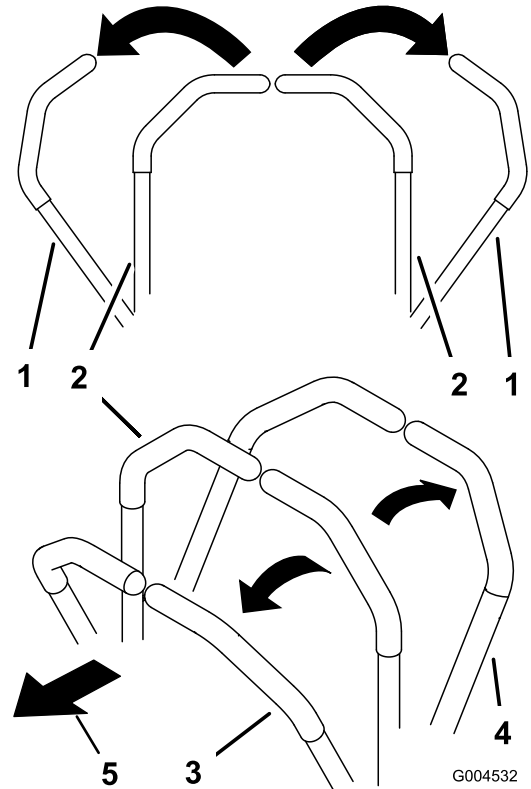

Figure 22

- | | |
|---|---------------------|
| 1. Motion-control lever—neutral-lock position | 4. Backward |
| 2. Center, unlocked position | 5. Front of machine |
| 3. Forward | |

Driving Forward

Note: The engine will kill if the traction-control levers are moved with the parking brake engaged.

To stop, pull the motion-control levers to the neutral position.

1. Release the parking brake; refer to [Releasing the Parking Brake \(page 21\)](#).
2. Move the levers to the center, unlocked position.
3. To go forward, slowly push the motion-control levers forward ([Figure 23](#)).

Stopping the Machine

To stop the machine, move the traction-control levers to neutral, and then move them to the locked position, disengage the power take off (blade-control switch (PTO)), and turn the ignition key to the Off position.

Set the parking brake when you leave the machine; refer to [Setting the Parking Brake \(page 20\)](#). Remember to remove the key from the ignition switch.

⚠ CAUTION

Children or bystanders may be injured if they move or attempt to operate the machine while it is unattended.

Always remove the ignition key and set the parking brake when leaving the machine unattended, even if just for a few minutes.

Adjusting the Height-of-Cut

Using the Transport Lock

The transport lock has 2 positions, and is used with the deck-lift pedal. There is a lock position and a unlock position for the transport position. The transport lock is used with the deck-lift pedal ([Figure 25](#)).

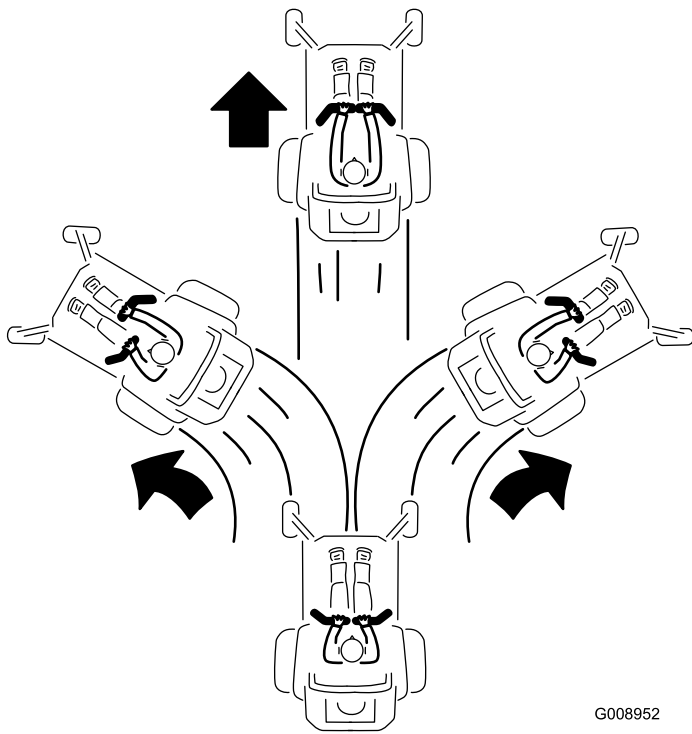

G008952

Figure 23

Driving Backward

1. Move the levers to the center, unlocked position.
2. To go backward, slowly pull the motion-control levers rearward ([Figure 24](#)).

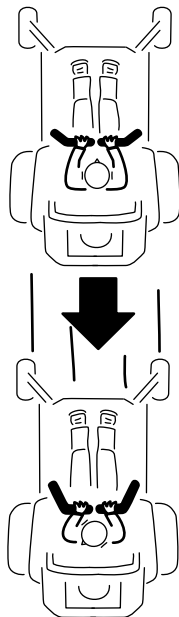

G008953

Figure 24

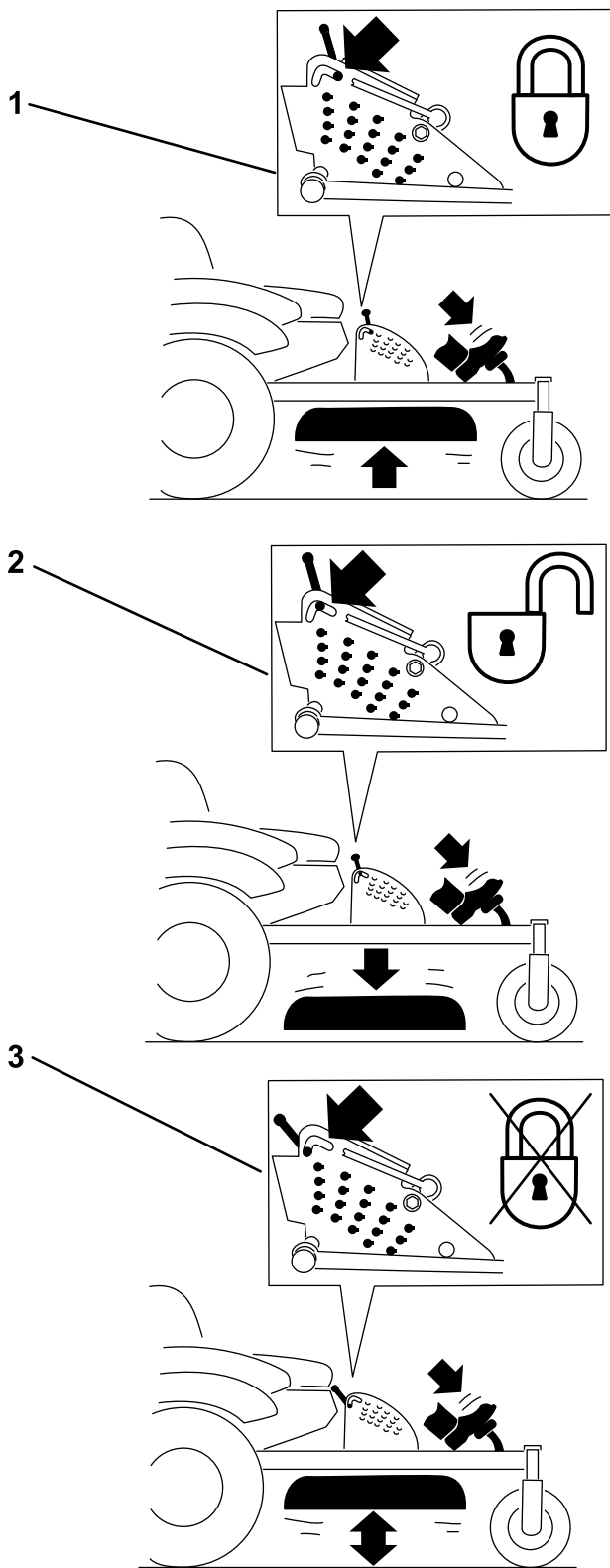

Figure 25

Transport-Lock Positions

- | | |
|---|--|
| <p>1. Transport lock</p> <p>2. Lock position—mower deck will lock into transport position</p> | <p>3. Unlock position—does not lock the mower deck into transport position</p> |
|---|--|

Adjusting the Height-of-Cut Pin

The height-of-cut is adjusted from 25 to 140 mm (1 to 5-1/2 inches) in 6 mm (1/4 inch) increments by relocating the clevis pin into different hole locations.

1. Move the transport lock to the lock position.
2. Push on the deck-lift pedal with your foot, and raise the mower deck to the transport position (also the 140 mm (5-1/2 inches) cutting height position) as shown in [Figure 26](#).
3. To adjust, rotate the pin 90 degrees and remove the pin from the height-of-cut bracket ([Figure 26](#)).
4. Select a hole in the height-of-cut bracket corresponding to the height-of-cut desired, and insert the pin ([Figure 26](#)).
5. Push on the deck lift, pull back on the transport lock, and slowly lower the mower deck.

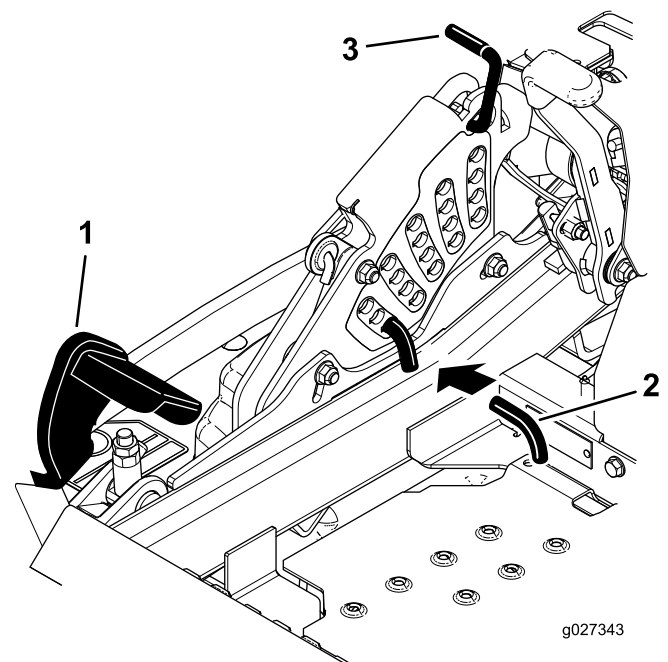

Figure 26

- | | |
|---|--------------------------|
| <p>1. Deck-lift pedal</p> <p>2. Cut-of-height pin</p> | <p>3. Transport lock</p> |
|---|--------------------------|

Adjusting the Anti-Scalp Rollers

Whenever you change the height-of-cut, it is recommended to adjust the height of the anti-scalp rollers.

1. Disengage the blade-control switch (PTO), move the motion-control levers to the neutral-locked position, and set the parking brake.
2. Stop the engine, remove the key, and wait for all moving parts to stop before leaving the operating position.
3. Adjust the anti-scalp rollers as shown in [Figure 27](#), [Figure 28](#), and [Figure 29](#).

ANTI-SCALP ROLLER ADJUSTMENT
 FOR MAXIMUM DECK FLOTATION,
 PLACE ROLLERS IN POSITIONS SHOWN.
 TURN ENGINE OFF BEFORE
 MAKING ROLLER ADJUSTMENTS.

- 1.5" / 38mm
- 2.0" / 51mm
- 2.5" / 63mm
- 3.0" / 76mm

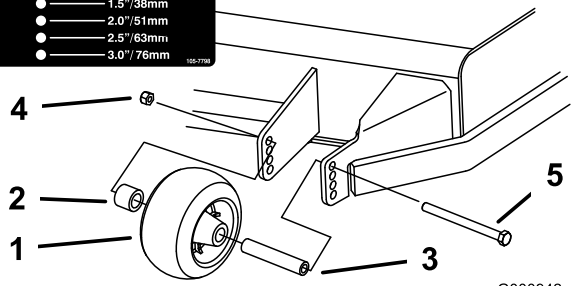

G000942

Figure 27

- 1. Anti-scalp roller
- 2. Spacer
- 3. Bushing
- 4. Flange nut
- 5. Bolt

ANTI-SCALP ROLLER ADJUSTMENT
 FOR MAXIMUM DECK FLOTATION,
 PLACE ROLLERS IN POSITIONS SHOWN.
 TURN ENGINE OFF BEFORE
 MAKING ROLLER ADJUSTMENTS.

- 1.5" / 38mm
- 2.0" / 51mm
- 2.5" / 63mm
- 3.0" / 76mm

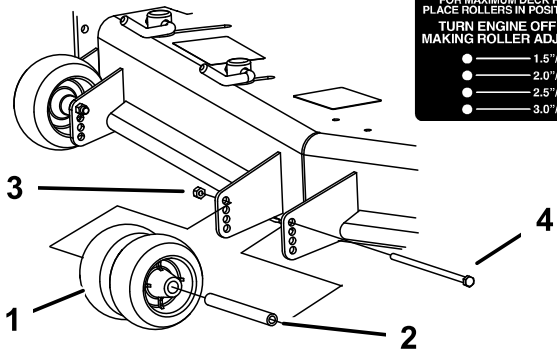

G000943

Figure 28

- 1. Anti-scalp roller
- 2. Bushing
- 3. Flange nut
- 4. Bolt

ANTI-SCALP ROLLER ADJUSTMENT
 FOR MAXIMUM DECK FLOTATION,
 PLACE ROLLERS IN POSITIONS SHOWN.
 TURN ENGINE OFF BEFORE
 MAKING ROLLER ADJUSTMENTS.

- 1.5" / 38mm
- 2.0" / 51mm
- 2.5" / 63mm
- 3.0" / 76mm

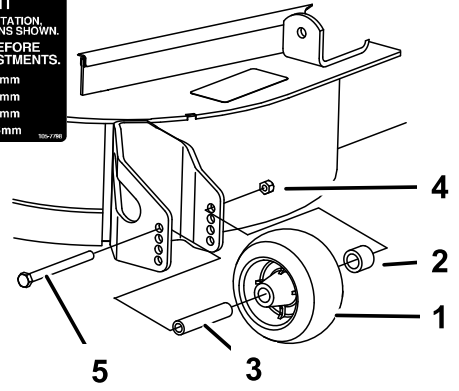

G000944

Figure 29

- 1. Anti-scalp roller
- 2. Spacer
- 3. Bushing
- 4. Flange nut
- 5. Bolt

Adjusting the Flow Baffle Cam Locks

This procedure is applicable only to machines with the flow-baffle locks. Certain models will have nuts and bolts in place of the flow-baffle locks and can be adjusted the same.

The mower-discharge flow can be adjusted for different types of mowing conditions. Position the cam locks and baffle to give the best quality of cut.

1. Disengage the blade-control switch (PTO), move the motion-control levers to the neutral-locked position, and set the parking brake.
2. Stop the engine, remove the key, and wait for all moving parts to stop before leaving the operating position.
3. To adjust the cam locks, swing the lever up to loosen the cam lock (Figure 30).
4. Adjust the baffle and cam locks in the slots to the desired discharge flow.
5. Swing the lever back over to tighten the baffle and cam locks (Figure 30).
6. If the cam locks do not lock the baffle into place or it is too tight, loosen the lever and then rotate the cam lock.

Note: Adjust the cam lock until the desired locking pressure is achieved.

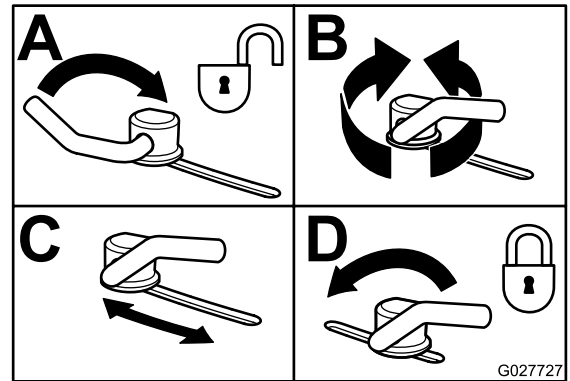

G027727

Figure 30

- 1. Unlock lever
- 2. Rotate the cam lock to increase or decrease locking pressure
- 3. Position the baffle
- 4. Lock lever

Positioning the Flow Baffle

The following figures are only recommendations for use. Adjustments will vary by grass type, moisture content, and the height of the grass.

Note: If the engine power draws down and the mower ground speed is the same, open up the baffle.

Position A

This is the full rear position. The suggested use for this position is as follows:

- Short, light grass mowing conditions
- Dry conditions
- Smaller grass clippings
- Propels grass clippings farther away from the mower

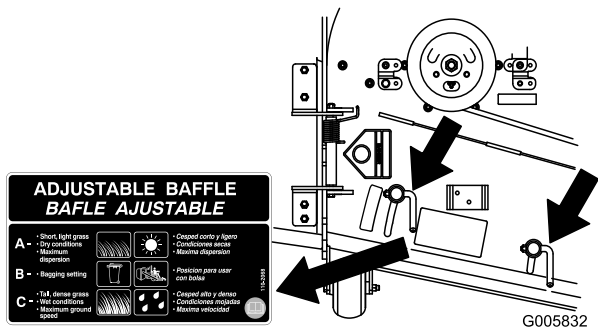

Figure 31

Position B

Use this position when bagging. Always align it with the blower opening.

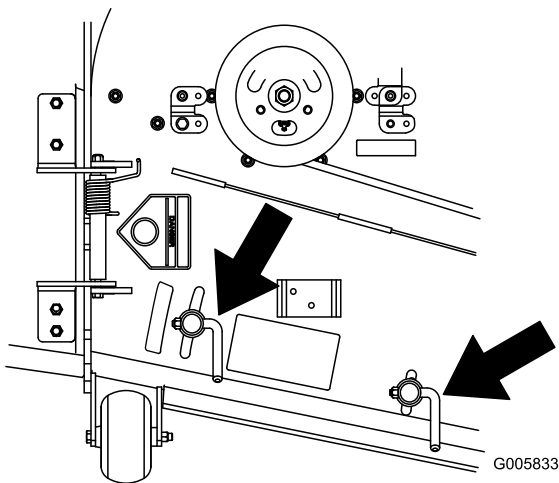

Figure 32

Position C

This is the full open position. The suggested use for this position is as follows:

- Tall, dense grass mowing conditions
- Wet conditions
- Lowers the engine-power consumption
- Allows increased ground speed in heavy conditions
- This position is similar to the benefits of the Toro SFS mower

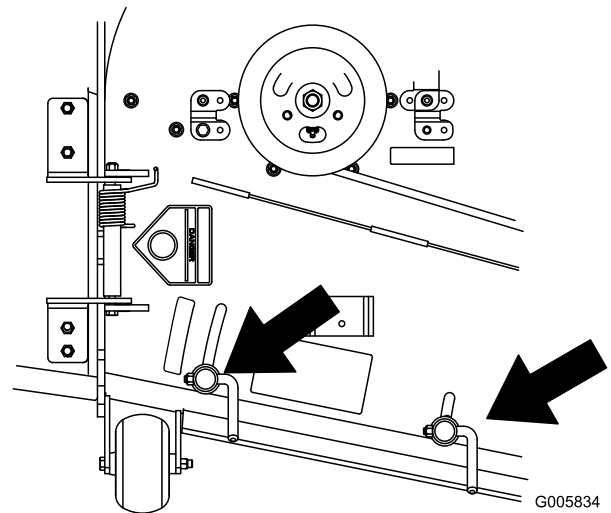

Figure 33

Positioning the Seat

The seat moves forward and backward. Position the seat where you have the best control of the machine and are most comfortable.

To adjust, move the lever sideways to unlock the seat (Figure 34).

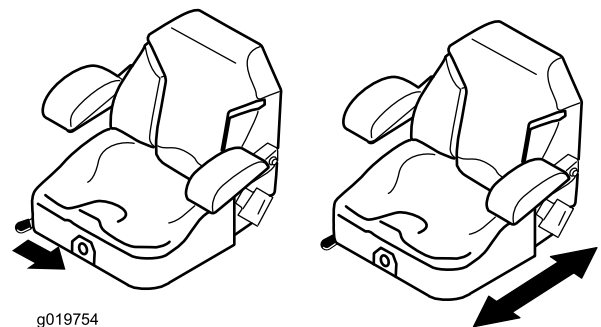

Figure 34

Unlatching the Seat

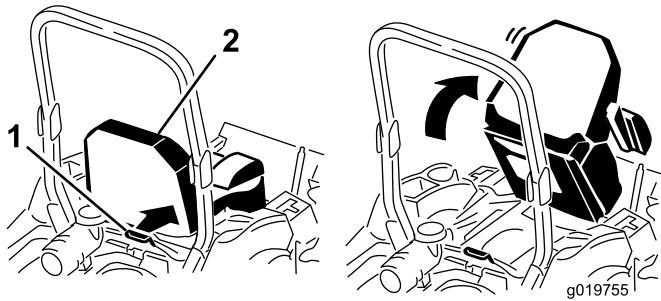

Figure 35

1. Seat latch

2. Seat

Changing the Seat Suspension

The seat adjusts to provide a smooth and comfortable ride. Position the seat where you are most comfortable.

To adjust, turn the knob in front either direction to provide the best comfort (Figure 36).

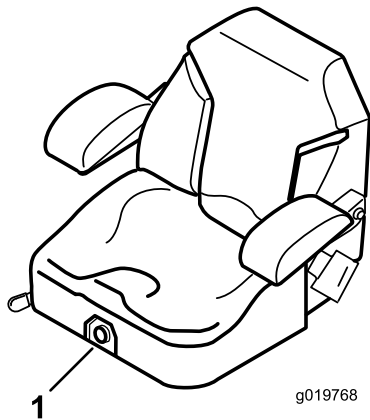

Figure 36

1. Seat-suspension knob

Using the Drive-Wheel-Release Valves

⚠ WARNING

Hands may become entangled in the rotating drive components below the engine deck, which could result in serious injury.

Stop the engine, remove the key, and allow all moving parts to stop before accessing the drive-wheel-release valves.

⚠ WARNING

The engine and hydraulic-drive units can become very hot. Touching a hot engine or hydraulic-drive units can cause severe burns.

Allow the engine and hydraulic-drive units to cool completely before accessing the drive-wheel-release valves.

The drive-wheel-release valves are located in the back of each hydraulic-drive unit, under the seat.

Note: Make sure the release valves are in the fully horizontal position when operating the machine or severe damage to the hydraulic system can occur.

1. Disengage the PTO (blade-control switch) and turn the ignition key to the Off position, move the levers to neutral-locked position, apply the parking brake, and remove the key.
2. Rotate the release-valve levers vertically to push the machine (Figure 37).

Note: This allows hydraulic oil to bypass the pump enabling the wheels to turn.

3. Disengage the parking brake before pushing the machine.

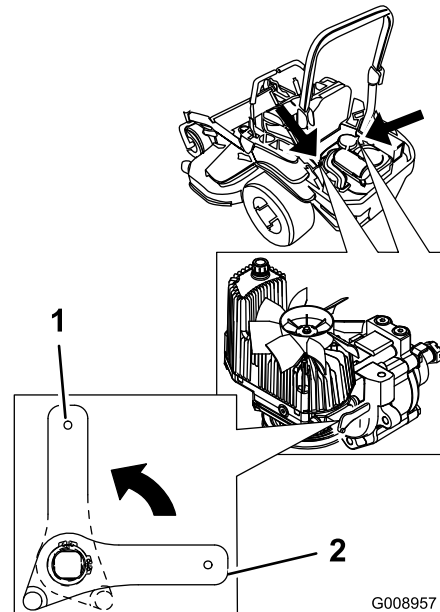

Figure 37

1. Vertical to push the machine

2. Horizontal to run the machine

4. Rotate the release-valve levers horizontally to run the machine (Figure 37).

Using the Side Discharge

The mower has a hinged grass deflector that disperses clippings to the side and down toward the turf.

⚠ DANGER

Without a grass deflector, discharge cover, or a complete grass-catcher assembly mounted in place, you and others are exposed to blade contact and thrown debris. Contact with rotating mower blade(s) and thrown debris will cause injury or death.

- Never remove the grass deflector from the mower because the grass deflector routes material down toward the turf. If the grass deflector is ever damaged, replace it immediately.
- Never put your hands or feet under the mower.
- Never try to clear the discharge area or mower blades unless you move the power take off (blade-control switch (PTO)) to the Off position, rotate the ignition key to the Off position, and remove the key.
- Make sure the grass deflector is in the down position.

Transporting the Machine

Use a heavy-duty trailer or truck to transport the machine. Ensure that the trailer or truck has all the necessary brakes, lighting, and marking as required by law. Please carefully read all the safety instructions. Knowing this information could help you, your family, pets or bystanders avoid injury.

⚠ WARNING

Driving on the street or roadway without turn signals, lights, reflective markings, or a slow moving vehicle emblem is dangerous and can lead to accidents causing personal injury.

Do not drive machine on a public street or roadway.

To transport the machine:

1. If using a trailer, connect it to the towing vehicle, and connect the safety chains.
2. If applicable, connect the trailer brakes.
3. Load the machine onto the trailer or truck.
4. Stop the engine, remove the key, set the brake, and close the fuel valve.
5. Use the metal tie-down loops on the machine to securely fasten the machine to the trailer or truck with straps, chains, cable, or ropes (Figure 38).

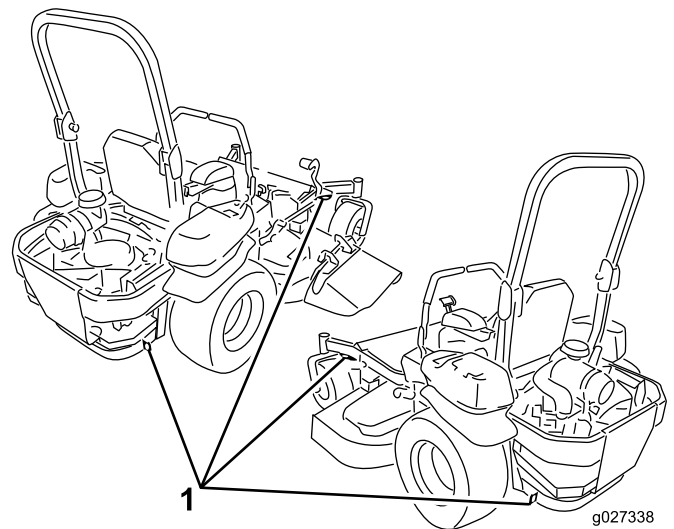

Figure 38

1. Traction unit tie-down loops

Loading the Machine

Use extreme caution when loading or unloading machines onto a trailer or a truck. Use a full-width ramp that is wider than the machine for this procedure. Back up ramps and drive forward down ramps (Figure 39).

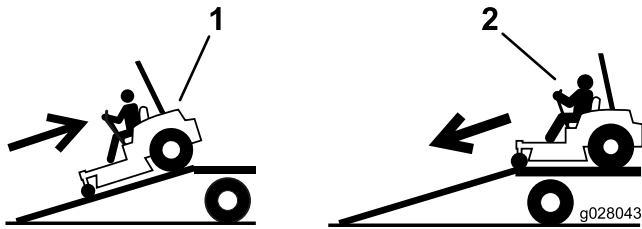

Figure 39

1. Back up ramps
2. Drive forward down ramps

Important: Do not use narrow individual ramps for each side of the machine.

Ensure the ramp is long enough so that the angle with the ground does not exceed 15 degrees (Figure 40). On flat ground, this requires a ramp to be at least 4 times as long as the height of the trailer or truck bed to the ground. A steeper angle may cause mower components to get caught as the unit moves from the ramp to the trailer or truck. Steeper angles may also cause the machine to tip or lose control. If loading on or near a slope, position the trailer or truck so that it is on the down side of the slope and the ramp extends up the slope. This will minimize the ramp angle.

⚠ WARNING

Loading a machine onto a trailer or truck increases the possibility of tip-over and could cause serious injury or death.

- Use extreme caution when operating a machine on a ramp.
- Ensure that the ROPS is in the up position and use the seat belt when loading or unloading the machine. Ensure that the ROPS will clear the top of an enclosed trailer.
- Use only a full-width ramp; do not use individual ramps for each side of the machine.
- Do not exceed a 15-degree angle between the ramp and the ground or between the ramp and the trailer or truck.
- Ensure the length of ramp is at least 4 times as long as the height of the trailer or truck bed to the ground. This will ensure that ramp angle does not exceed 15 degrees on flat ground.
- Back up ramps and drive forward down ramps.
- Avoid sudden acceleration or deceleration while driving the machine on a ramp as this could cause a loss of control or a tip-over situation.

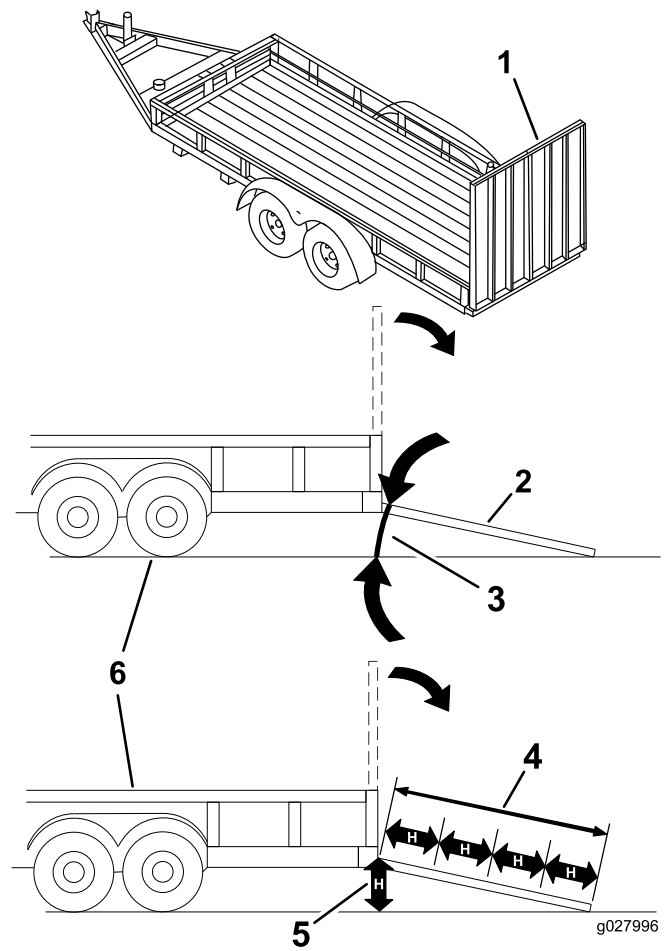

Figure 40

1. Full-width ramp in stowed position
2. Side view of full-width ramp in loading position
3. Not greater than 15 degrees
4. Ramp is at least 4 times as long as the height of the trailer or truck bed to the ground
5. H= height of the trailer or truck bed to the ground
6. Trailer

Operating Tips

Cutting a Lawn for the First Time

Cut grass slightly longer than normal to ensure that the cutting height of the mower does not scalp any uneven ground. However, the cutting height used in the past is generally the best one to use. When cutting grass longer than six inches tall, you may want to cut the lawn twice to ensure an acceptable quality of cut.

Cutting 1/3 of the Grass Blade

It is best to cut only about 1/3 of the grass blade. Cutting more than that is not recommended unless grass is sparse, or it is late fall when grass grows more slowly.

Alternating the Mowing Direction

Alternate mowing direction to keep the grass standing straight. This also helps disperse clippings which enhances decomposition and fertilization.

Mowing at Correct Intervals

Normally, mow every four days. But remember, grass grows at different rates at different times. So to maintain the same cutting height, which is a good practice, mow more often in early spring. As the grass growth rate slows in mid summer, mow less frequently. If you cannot mow for an extended period, first mow at a high cutting height; then mow again two days later at a lower height setting.

Adjusting the Cutting Speed

To improve cut quality, use a slower ground speed in certain conditions.

Avoiding Cutting Too Low

If the cutting width of the mower is wider than the mower you previously used, raise the cutting height to ensure that uneven turf is not cut too short.

Cutting Long Grass

If the grass is ever allowed to grow slightly longer than normal, or if it contains a high degree of moisture, raise the cutting height higher than usual and cut the grass at this setting. Then cut the grass again using the lower, normal setting.

Stopping the Machine

If the machine's forward motion must be stopped while mowing, a clump of grass clippings may drop onto your lawn. To avoid this, move onto a previously cut area with the blades engaged.

Keeping the Underside of the Mower Clean

Clean clippings and dirt from the underside of the mower after each use. If grass and dirt build up inside the mower, cutting quality will eventually become unsatisfactory.

Maintaining the Blade

Maintain a sharp blade throughout the cutting season because a sharp blade cuts cleanly without tearing or shredding the grass blades. Tearing and shredding turns grass brown at the edges, which slows growth and increases the chance of disease. Check the cutter blades daily for sharpness, and for any wear or damage. File down any nicks and sharpen the blades as necessary. If a blade is damaged or worn, replace it immediately with a genuine TORO replacement blade.

Maintenance

Recommended Maintenance Schedule(s)

Maintenance Service Interval	Maintenance Procedure
After the first 8 hours	<ul style="list-style-type: none"> • Change the engine oil.
After the first 100 hours	<ul style="list-style-type: none"> • Check the wheel lug-nut torque. • Check the wheel hub slotted-nut torque. • Check the parking brake adjustment.
After the first 250 hours	<ul style="list-style-type: none"> • Change the hydraulic filters and hydraulic oil when using any type of oil.
Before each use or daily	<ul style="list-style-type: none"> • Check the safety system. • Check the engine-oil level. • Check the seat belt. • Check the rollover protection system (ROPS) knobs. • Clean the engine screen. • Check and clean the hydraulic-unit shrouds. • Inspect the blades. • Clean the mower deck.
Every 50 hours	<ul style="list-style-type: none"> • Grease the mower-deck spindles and the idler arm. • Check the spark arrester (if equipped). • Check the tire pressure. • Inspect the belts for cracks and wear. • Check the hydraulic oil level.
Every 100 hours	<ul style="list-style-type: none"> • Lubricate the mower-deck-lift pivots. • Change the engine oil (more often in dirty or dusty conditions). • Check, clean and regap the spark plug.
Every 150 hours	<ul style="list-style-type: none"> • Inspect the primary filter. • Service the engine-oil cooler. • Clean the engine-cooling fins and shrouds.
Every 200 hours	<ul style="list-style-type: none"> • Change the engine-oil filter. • Replace the fuel filter (more often in dirty or dusty conditions).
Every 250 hours	<ul style="list-style-type: none"> • Change the hydraulic filters and hydraulic oil when using Mobil® 1 oil (more often in dirty or dusty conditions).
Every 300 hours	<ul style="list-style-type: none"> • Replace the primary air filter (more often in dusty or sandy conditions). • Check the inner air filter.
Every 500 hours	<ul style="list-style-type: none"> • Check the wheel lug-nut torque. • Check the wheel hub slotted-nut torque. • Adjust the caster-pivot bearing. • Check the parking brake adjustment. • Change the hydraulic filters and hydraulic oil when using Toro® HYPR-OIL™ 500 hydraulic oil (more often in dirty or dusty conditions).
Every 600 hours	<ul style="list-style-type: none"> • Replace the inner air filter.
Monthly	<ul style="list-style-type: none"> • Check the battery charge.
Yearly	<ul style="list-style-type: none"> • Grease the pump-belt-idler arm. • Grease the front caster pivots (more often in dirty or dusty conditions). • Repack the front caster-wheel bearings (more often in dirty or dusty conditions). • Lubricate the caster-wheel hubs.
Yearly or before storage	<ul style="list-style-type: none"> • Paint chipped surfaces. • Check all maintenance procedures listed above before storage.

Important: Refer to your engine operator's manual for additional maintenance procedures.

▲ CAUTION

If you leave the key in the ignition switch, someone could accidentally start the engine and seriously injure you or other bystanders.

Remove the key from the ignition before you do any maintenance.

Lubrication

Grease more frequently when operating conditions are extremely dusty or sandy.

Grease Type: No. 2 general purpose, lithium-based or molybdenum-based grease

1. Disengage the blade control switch (PTO), move the motion-control levers to the neutral-locked position, and set the parking brake.
2. Stop the engine, remove the key, and wait for all moving parts to stop before leaving the operating position.
3. Clean the grease fittings with a rag.

Note: Make sure to scrape any paint off the front of the fitting(s).

4. Connect a grease gun to the fitting.
5. Pump grease into the fittings until grease begins to ooze out of the bearings.
6. Wipe up any excess grease.

Adding Light Oil or Spray Lubrication

Service Interval: Every 100 hours

Lubricate the deck-lift pivots.

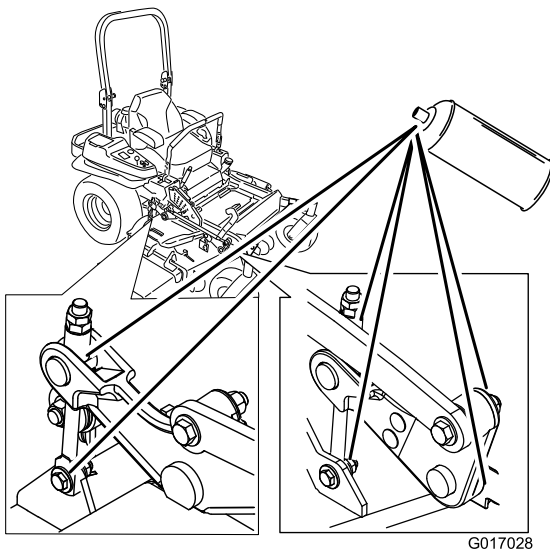

Figure 41

Greasing the Mower

Service Interval: Every 50 hours—Grease the mower-deck spindles and the idler arm.

Yearly—Grease the pump-belt-idler arm.

Yearly—Grease the front caster pivots (more often in dirty or dusty conditions).

Yearly—Repack the front caster-wheel bearings (more often in dirty or dusty conditions).

Important: Make sure cutting unit spindles are full of grease weekly.

1. Disengage the blade control switch (PTO), move the motion-control levers to the neutral-locked position, and set the parking brake.
2. Stop the engine, remove the key, and wait for all moving parts to stop before leaving the operating position.
3. Grease the mower deck idler-pulley pivot until grease come out the bottom (Figure 42).
4. Grease the 3 spindle bearings until grease comes out (Figure 42).

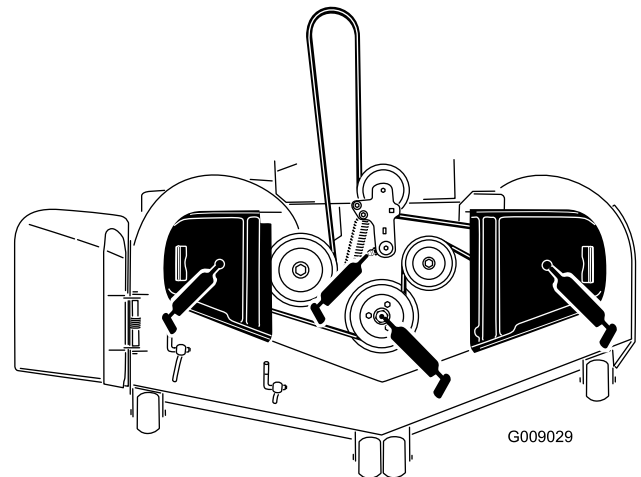

Figure 42

5. Grease the drive-belt-idler arm (Figure 43).

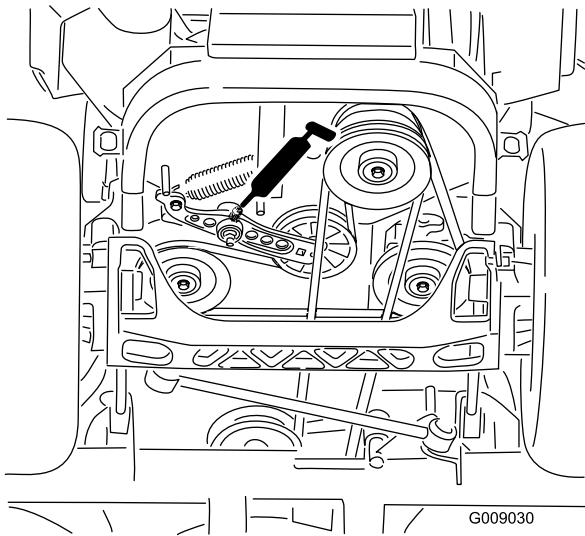

Figure 43

6. Remove the dust cap and adjust the caster pivots.

Note: Keep the dust cap off until greasing is done; refer to [Adjusting the Caster-Pivot Bearing](#) (page 46).

7. Remove the hex plug.
8. Thread a grease fitting into the hole.
9. Pump grease into the fitting until it oozes out around the top bearing.
10. Remove the grease fitting in the hole.
11. Install the hex plug and dust cap (Figure 44).

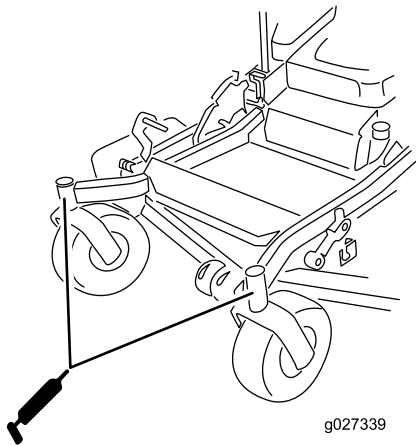

Figure 44

12. Grease the caster-wheel bearings (Figure 44).

Lubricating the Caster-Wheel Hubs

Service Interval: Yearly

1. Stop the engine, wait for all moving parts to stop, remove the key, and engage the parking brake.

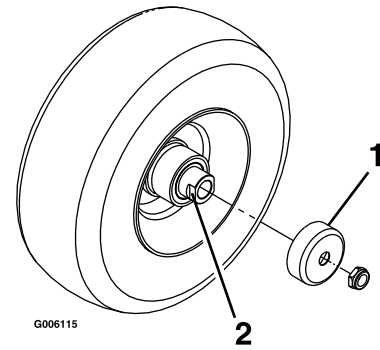

Figure 45

1. Seal guard
2. Spacer nut with wrench flats

2. Raise the mower for access.
3. Remove the caster wheel from the caster forks.
4. Remove the seal guards from the wheel hub.
5. Remove one of the spacer nuts from the axle assembly in the caster wheel.

Note: Thread-locking adhesive has been applied to lock the spacer nuts to the axle.

6. Remove the axle (with the other spacer nut still assembled to it) from the wheel assembly.
7. Pry out seals and inspect bearings for wear or damage and replace if necessary.
8. Pack the bearings with a general-purpose grease.
9. Insert 1 bearing and 1 new seal into the wheel.

Note: The seals must be replaced.

10. If the axle assembly has had both spacer nuts removed (or broken loose), apply a thread-locking adhesive to 1 spacer nut, and thread it onto the axle with the wrench flats facing outward.

Note: Do not thread the spacer nut all of the way onto the end of the axle. Leave approximately 3 mm (1/8 inch) from the outer surface of the spacer nut to the end of the axle inside the nut.

11. Insert the assembled nut and axle into the wheel on the side of the wheel with the new seal and bearing.
12. With the open end of the wheel facing up, fill the area inside the wheel around the axle full of general-purpose grease.
13. Insert the second bearing and new seal into the wheel.

14. Apply a thread-locking adhesive to the second spacer nut, and thread it onto the axle with the wrench flats facing outward.
15. Torque the nut to 8 to 9 N-m (75 to 80 in-lb), loosen, then torque to 2 to 3 N-m (20 to 25 in-lb).
Note: Make sure axle does not extend beyond either nut.
16. Install the seal guards over the wheel hub, and insert wheel into the caster fork.
17. Install the caster bolt and tighten the nut fully.

Important: To prevent seal and bearing damage, check the bearing adjustment often. Spin the caster tire. The tire should not spin freely (more than 1 or 2 revolutions) or have any side play. If the wheel spins freely, adjust the torque on the spacer nut until there is a slight amount of drag. Apply another layer of thread-locking adhesive.

Engine Maintenance

⚠ WARNING

Contact with hot surfaces may cause personal injury.

Keep hands, feet, face, clothing and other body parts away the muffler and other hot surfaces.

Servicing the Air Cleaner

Service Interval: Every 150 hours—Inspect the primary filter.

Every 300 hours/Yearly (whichever comes first)—Replace the primary air filter (more often in dusty or sandy conditions).

Every 300 hours—Check the inner air filter.

Every 600 hours—Replace the inner air filter.

Note: Check the filters more frequently if the operating conditions are extremely dusty or sandy.

Removing the Filters

1. Disengage the PTO, move the motion-control levers to the neutral-locked position, and set the parking brake.
2. Stop the engine, remove the key, and wait for all moving parts to stop before leaving the operating position.
3. Release the latches on the air cleaner, and pull the air-cleaner cover off the air-cleaner body (Figure 46).
4. Clean the inside of the air-cleaner cover with compressed air.
5. Gently slide the primary filter out of the air-cleaner body (Figure 46).

Note: Avoid knocking the filter into the side of the body.

6. Remove the inner filter only if you intend to replace it.

Important: Never attempt to clean the inner filter. If the inner filter is dirty, then the primary filter is damaged. Replace both filters.

7. Inspect the primary filter for damage by looking into the filter while shining a bright light on the outside of the filter. Holes in the filter will appear as bright spots. If the filter is damaged discard it.

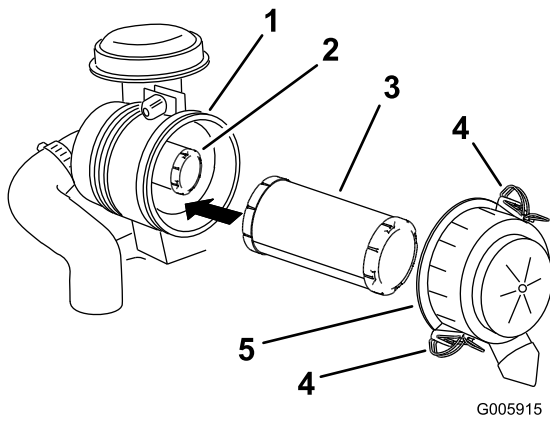

Figure 46

- | | |
|-----------------------|----------------------|
| 1. Air-cleaner body | 4. Air-cleaner latch |
| 2. Inner air filter | 5. Air-cleaner cover |
| 3. Primary air filter | |

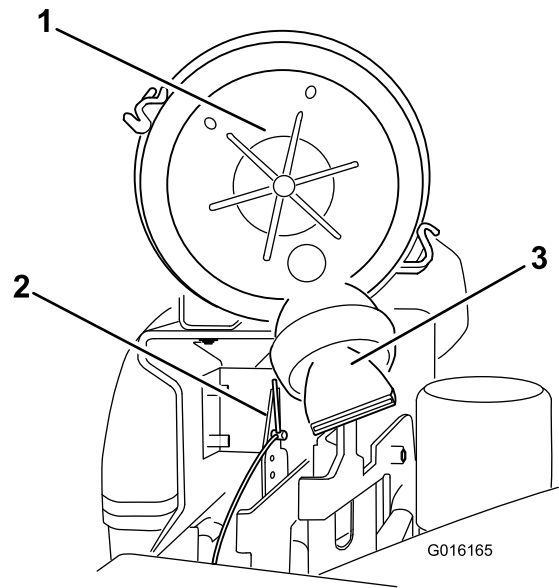

Figure 47

- | | |
|-----------------------|------------------|
| 1. Air-cleaner cover | 3. Breathe valve |
| 2. Throttle mechanism | |

- Secure the cover with the latches (Figure 46).

Servicing the Primary Filter

- If the primary filter is dirty, bent, or damaged, replace it.
- Do not clean the primary filter.

Servicing the Inner Filter

Replace the inner filter, never clean it.

Important: Never attempt to clean the safety filter. If the safety filter is dirty, then the primary filter is damaged. Replace both filters.

Installing the Filters

Important: To prevent engine damage, always operate the engine with both air filters and cover installed.

- If installing new filters, check each filter for shipping damage.

Note: Do not use a damaged filter.

- If the inner filter is being replaced, carefully slide it into the filter body (Figure 46).
- Carefully slide the primary filter over the inner filter (Figure 46).

Note: Ensure that the primary filter is fully seated by pushing on its outer rim while installing it.

Important: Do not press on the soft inside area of the filter.

- Position the air-cleaner cover, so that the breather valve does not interfere with the throttle mechanism (Figure 47).

Servicing the Engine Oil

Oil Type: Detergent oil (API service class SJ or higher)

Oil Capacity: with a filter change, 2.9 L (99 oz)

Viscosity: See the table below.

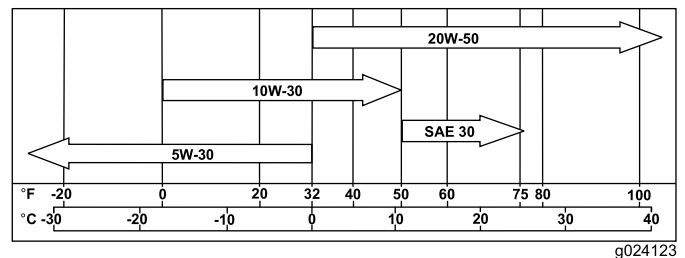

Figure 48

Note: Use of synthetic oil having 5W-30 rating is acceptable up to 4° C (40° F).

Note: Synthetic oils will provide better starting in extreme cold below -23° C (-10° F).

Checking the Engine-Oil Level

Service Interval: Before each use or daily

Note: Check the oil when the engine is cold.

⚠ WARNING

Contact with hot surfaces may cause personal injury.

Keep hands, feet, face, clothing, and other body parts away from the muffler and other hot surfaces.

Important: Do not overfill the crankcase with oil because damage to the engine may result. Do not run engine with oil below the Low mark because the engine may be damaged.

1. Disengage the PTO, move the motion-control levers to the neutral-locked position, and set the parking brake.
2. Stop the engine, remove the key, and wait for all moving parts to stop before leaving the operating position (Figure 49).

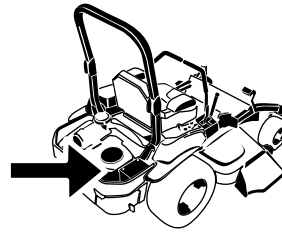

G008804

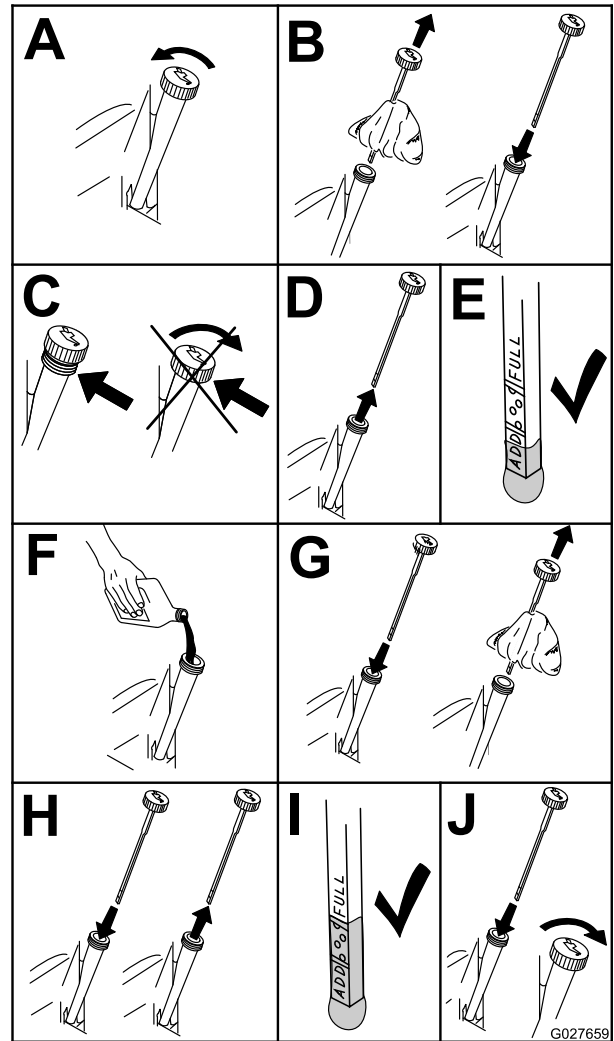

Figure 49

Changing the Engine Oil

Service Interval: After the first 8 hours

Every 100 hours (more often in dirty or dusty conditions).

Note: Dispose of the used oil at a recycling center.

1. Start the engine and let it run for 5 minutes.
Note: This warms the oil so it drains better.
2. Park the machine so that the rear is slightly lower than the front to ensure that the oil drains completely.
3. Disengage the PTO, move the motion-control levers to the neutral-locked position, and set the parking brake.
4. Stop the engine, remove the key, and wait for all moving parts to stop before leaving the operating position (Figure 50).

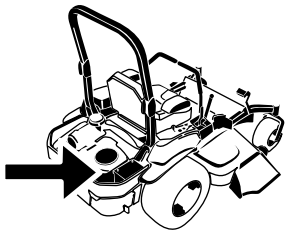

G008804

5. Slowly pour approximately 80% of the specified oil into the filler tube and slowly add the additional oil to bring it to the **Full** mark (Figure 51).

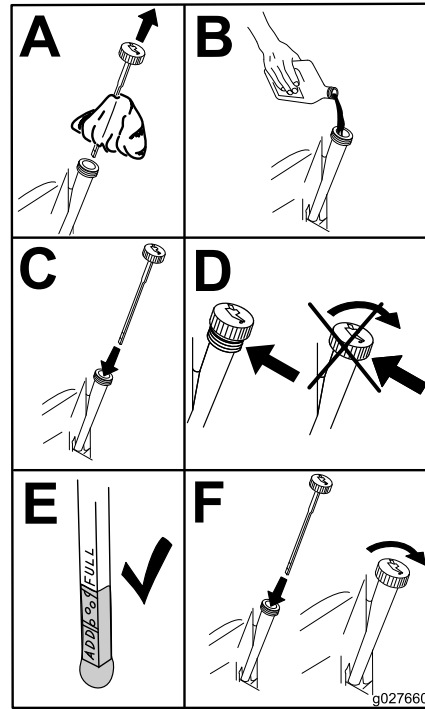

Figure 51

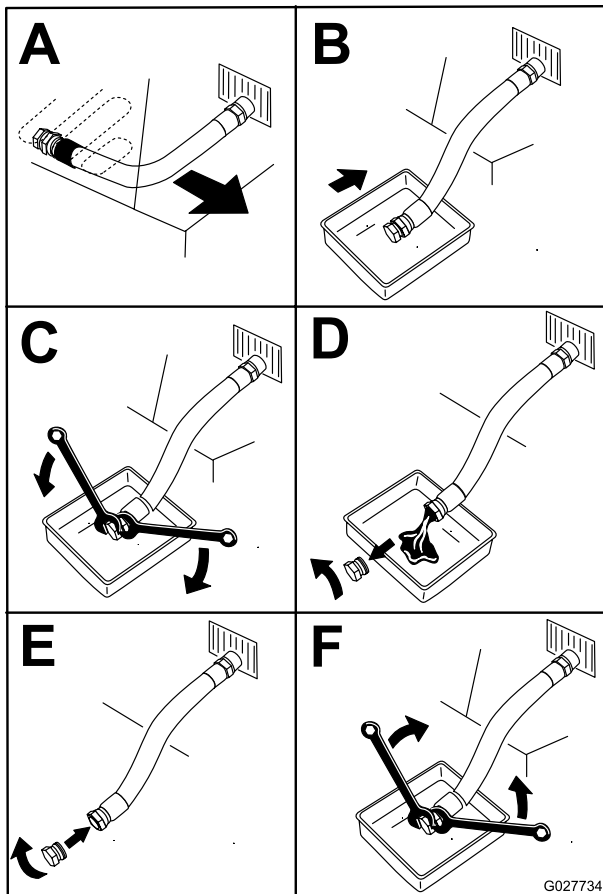

Figure 50

6. Start the engine and drive to a flat area.
7. Check the oil level again.

Changing the Engine-Oil Filter

Service Interval: Every 200 hours

Note: Change the engine-oil filter more frequently when operating conditions are extremely dusty or sandy.

1. Drain the oil from the engine; refer to [Changing the Engine Oil \(page 39\)](#).
2. Change the engine-oil filter ([Figure 52](#)).

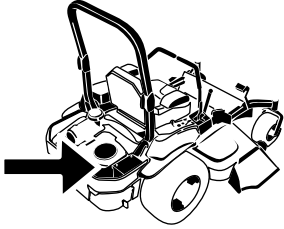

G008804

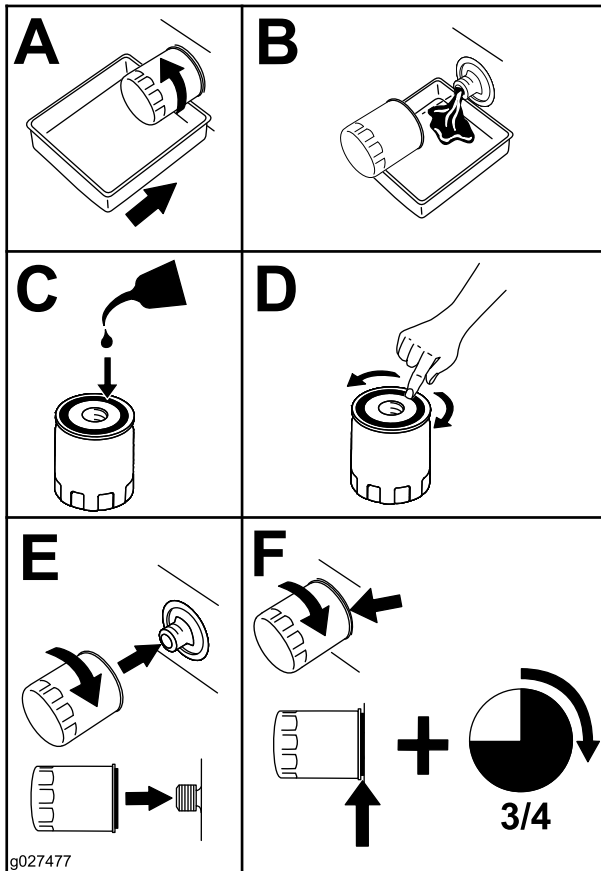

Figure 52

Note: Ensure the oil-filter gasket touches the engine, and then an extra 3/4 turn is completed.

3. Fill the crankcase with the proper type of new oil; refer to [Changing the Engine Oil \(page 39\)](#).

Servicing the Spark Plug

Service Interval: Every 100 hours

Make sure the air gap between the center and side electrodes is correct before installing the spark plug. Use a spark plug wrench for removing and installing the spark plug(s) and a gapping tool/feeler gauge to check and adjust the air gap. Install a new spark plug(s) if necessary.

Type : Champion® RC12YC or equivalent

Air Gap: 0.76 mm (0.03 inch)

Removing the Spark Plug

1. Stop the engine, remove the key, and wait for all moving parts to stop before leaving the operating position.
2. Disengage the PTO, move the motion-control levers to the neutral-locked position, and set the parking brake.
3. Remove the left hand hydraulic-unit shroud in the order listed in [Figure 53](#).

Note: This gives you access to the front spark plug.



G009922

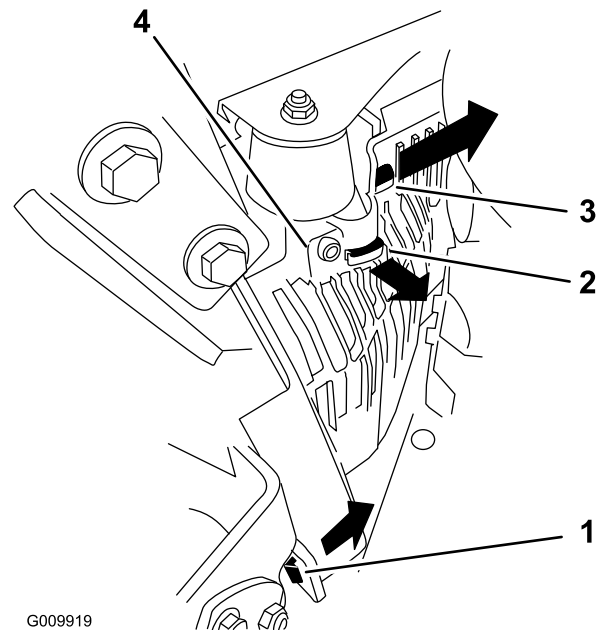

G009919

Figure 53

1. Pull this tab out to the side in the direction of the arrow
2. Pull the shroud off this frame tab in the direction of the arrow
3. Pull the shroud off this frame tab in the direction of the arrow
4. Shroud

- Remove the spark plug.

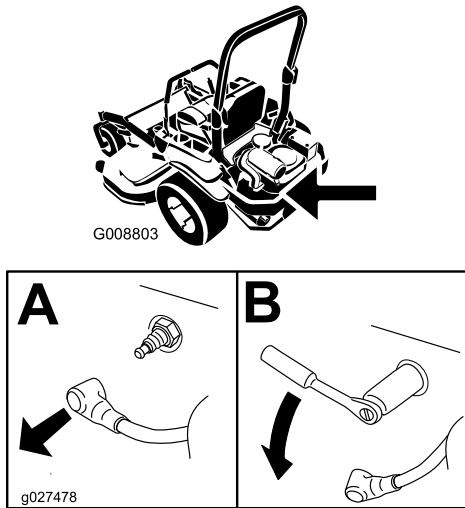

Figure 54

- Install the left hand hydraulic-unit shroud (Figure 53).

Checking the Spark Plug

Important: Do not clean the spark plug(s). Always replace the spark plug(s) when it has: a black coating, worn electrodes, an oily film, or cracks.

If you see light brown or gray on the insulator, the engine is operating properly. A black coating on the insulator usually means the air cleaner is dirty.

Set the gap to 0.76 mm (0.03 inch).

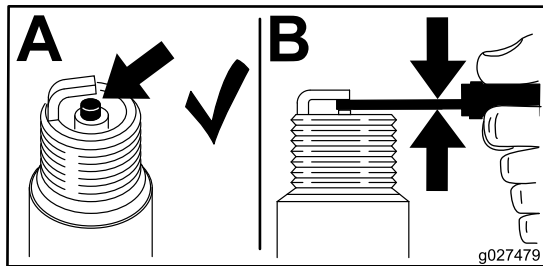

Figure 55

Installing the Spark Plug

Tighten the spark plug(s) to 24.4 to 29.8 N-m (18 to 22 ft-lb).

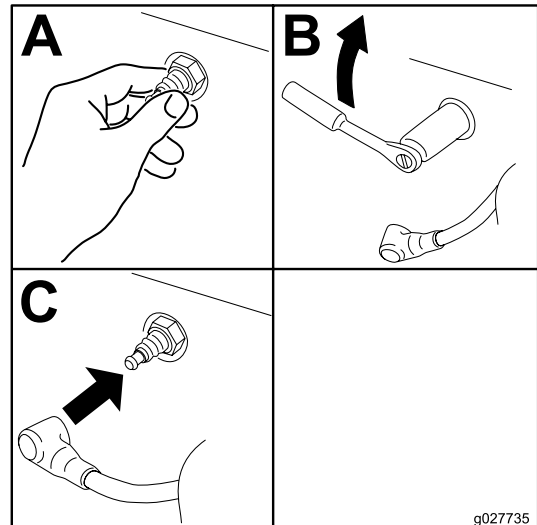

Figure 56

Checking the Spark Arrester (if equipped)

Service Interval: Every 50 hours

⚠ WARNING

Hot exhaust system components may ignite gasoline vapors even after the engine is stopped. Hot particles exhausted during engine operation may ignite flammable materials. Fire may result in personal injury or property damage.

Do not fuel or run engine unless spark arrester is installed.

- Stop engine, wait for all moving parts to stop, remove the key, and engage the parking brake.
- Wait for muffler to cool.
- If there are any breaks in the screen or welds are observed, replace the arrester.
- If plugging of the screen is observed, remove the arrester and shake loose particles out of the arrester, and clean screen it with a wire brush (soak in solvent if necessary).
- Install arrester on exhaust outlet.

Fuel System Maintenance

⚠ WARNING

Fuel-system components are under high pressure. The use of improper components can result in system failure, gasoline leakage, and possible explosion.

Use only approved fuel lines and fuel filters.

Servicing the Electronic Fuel-Injection System

This machine contains an electronic fuel-injection system. It controls the fuel flow under different operating conditions.

The electronic-control unit (ECU) continuously monitors the operation of the EFI system.

If a problem or fault within the system is detected, the malfunction indicator light (MIL) is illuminated. The MIL is the red light located in the right console panel.

Once the MIL illuminates, initial trouble shooting checks should be made; refer to the MIL section under [Troubleshooting \(page 67\)](#).

If these checks do not correct the problem, further diagnosis and servicing by an Authorized Service Dealer is necessary.

Replacing the Low-Pressure Fuel Filter

Service Interval: Every 200 hours/Yearly (whichever comes first) (more often in dirty or dusty conditions).

The fuel filter is located near the engine on the front or rear side of the engine.

1. Disengage the PTO, move the motion-control levers to the neutral-locked position, and set the parking brake.
2. Stop the engine, remove the key, and wait for all moving parts to stop before leaving the operating position.
3. Allow the machine to cool down.
4. Stop the engine, remove the key, and wait for all moving parts to stop before leaving the operating position.
5. Close the fuel-shutoff valve under the seat ([Figure 57](#)).

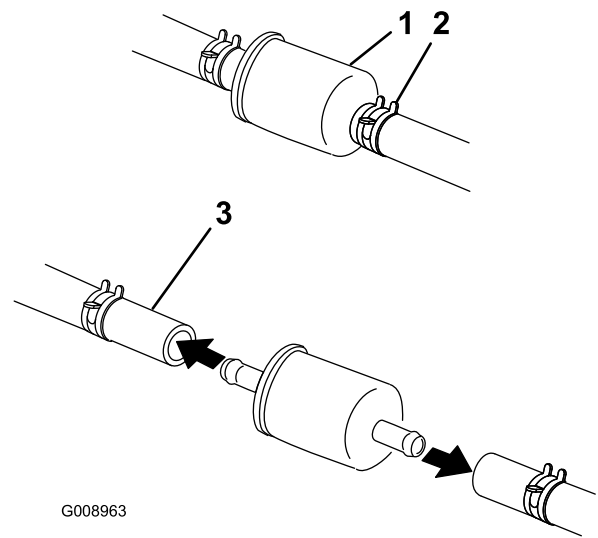

Figure 57

1. Fuel filter
2. Hose clamp
3. Fuel line

6. Squeeze the ends of the hose clamps together and slide them away from the filter ([Figure 57](#)).
7. Remove the filter from the fuel lines.
8. Install a new filter and move the hose clamps close to the filter ([Figure 57](#)).
9. Open the fuel-shutoff valve.

Note: It is important to reinstall the fuel line hoses and secure with plastic ties the same as they were originally installed at the factory to keep the fuel line away from components that could cause fuel line damage.

Servicing the High-Pressure Fuel Filter

Do not attempt to service the high-pressure fuel filter. The high-pressure filter is integrated within the fuel-pump module. The fuel filter and other components inside the fuel-pump module are not serviceable. **Do not** attempt to open the fuel-pump module.

Ensure that an Authorized Service Dealer replaces the fuel-pump module with the high-pressure fuel filter.

Servicing the Fuel Tank

Do not attempt to drain the fuel tank. Ensure that an Authorized Service Dealer drains the fuel tank.

Electrical System Maintenance

Servicing the Battery

Service Interval: Monthly

WARNING

CALIFORNIA Proposition 65 Warning

Battery posts, terminals, and related accessories contain lead and lead compounds, chemicals known to the State of California to cause cancer and reproductive harm.
Wash hands after handling.

⚠ DANGER

Battery electrolyte contains sulfuric acid which is a deadly poison and causes severe burns.

Do not drink electrolyte and avoid contact with skin, eyes, or clothing. Wear safety glasses to shield your eyes and rubber gloves to protect your hands.

Removing the Battery

⚠ WARNING

Battery terminals or metal tools could short against metal machine components causing sparks. Sparks can cause the battery gasses to explode, resulting in personal injury.

- When removing or installing the battery, do not allow the battery terminals to touch any metal parts of the machine.
- Do not allow metal tools to short between the battery terminals and metal parts of the machine.

⚠ WARNING

Incorrect battery cable routing could damage the machine and cables causing sparks. Sparks can cause the battery gasses to explode, resulting in personal injury.

- Always disconnect the negative (black) battery cable before disconnecting the positive (red) cable.
- Always reconnect the positive (red) battery cable before connecting the negative (black) cable.

1. Disengage the blade-control switch (PTO), move the motion-control levers to the neutral-locked position, and set the parking brake.
2. Stop the engine, remove the key, and wait for all moving parts to stop before leaving the operating position.
3. Disconnect the negative battery cable (black) from the negative (-) battery terminal (Figure 58).
4. Slide the red terminal boot off the positive (red) battery terminal, and remove the positive (+) battery cable (Figure 58).
5. Remove the wing nut securing the battery clamp (Figure 58).
6. Remove the clamp (Figure 58).
7. Remove the battery.

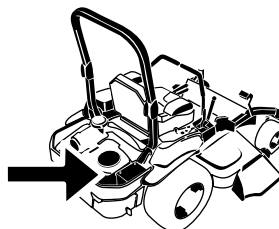

G008804

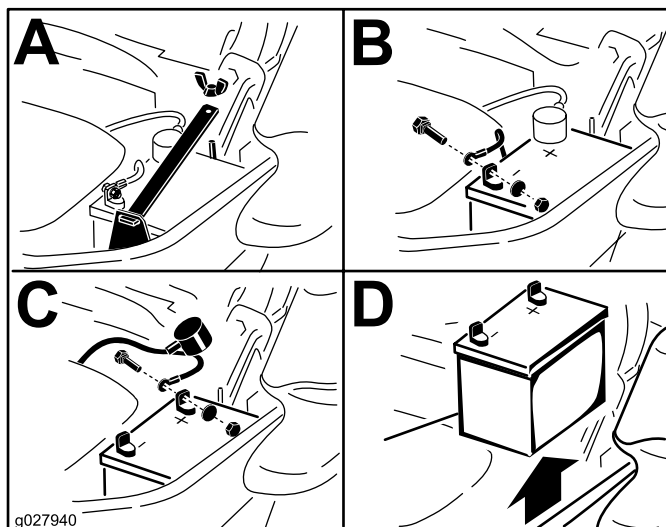

Figure 58

1. Remove the wing nut and clamp
2. Remove the negative battery cable before the positive
3. Remove the positive battery cable
4. Remove the battery

Installing the Battery

1. Position the battery in the tray with the terminal posts opposite from the hydraulic tank (Figure 58).
2. Install the positive (red) battery cable to positive (+) battery terminal.
3. Install the negative (black) battery cable and ground wire to the negative (-) battery terminal.
4. Secure the cables with 2 bolts, 2 washers, and 2 locknuts (Figure 58).
5. Slide the red terminal boot onto the positive (red) battery post.
6. Install the clamp and secure it with the wing nut (Figure 58).

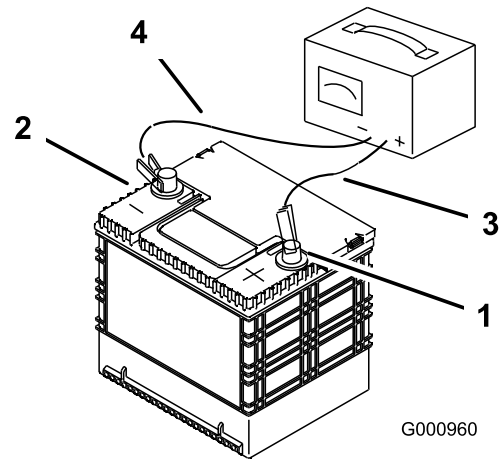

Figure 59

1. Positive battery post
2. Negative battery post
3. Red (+) charger lead
4. Black (-) charger lead

Charging the Battery

⚠ WARNING

Charging the battery produces gasses that can explode.

Never smoke near the battery and keep sparks and flames away from battery.

Important: Always keep the battery fully charged (1.265 specific gravity). This is especially important to prevent battery damage when the temperature is below 0°C (32°F).

1. Charge battery for 10 to 15 minutes at 25 to 30 amps or 30 minutes at 10 amps.
2. When the battery is fully charged, unplug the charger from the electrical outlet, then disconnect the charger leads from the battery posts (Figure 59).
3. Install the battery in the machine and connect the battery cables; refer to [Installing the Battery](#) (page 44).

Note: Do not run the machine with the battery disconnected, electrical damage may occur.

Servicing the Fuses

The electrical system is protected by fuses. It requires no maintenance, however, if a fuse blows check the component/circuit for a malfunction or short.

1. The fuses are located on right hand console next to the seat (Figure 60).
2. To replace the fuses, pull out on the fuse to remove it.
3. Install a new fuse (Figure 60).

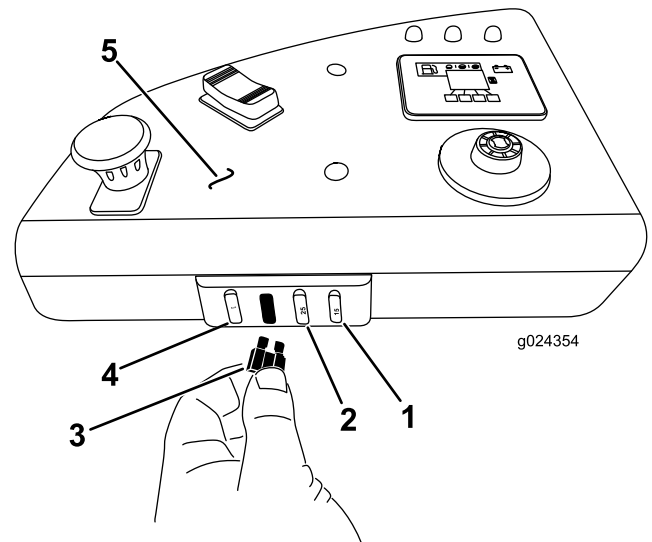

Figure 60

1. Optional accessory—15 amp
2. Charge—25 amp
3. PTO—10 amp
4. Main—25 amp
5. Console

Drive System Maintenance

Checking the Seat Belt

Service Interval: Before each use or daily

Visually inspect the seat belt for wear, cuts, and proper operation of the retractor and the buckle. Replace before operating if damaged.

Checking the Rollover Protection System (ROPS) Knobs

Service Interval: Before each use or daily

⚠ WARNING

To avoid injury or death from rollover: keep the roll bar in the fully raised locked position and use the seat belt.

Ensure the seat is secured to the machine.

Check that both the mounting hardware and the knobs are in good working condition. Make sure that the knobs are fully engaged with the ROPS in the raised position. The upper hoop of the roll bar may need to be pushed forward or pulled rearward to get both knobs fully engaged (Figure 61).

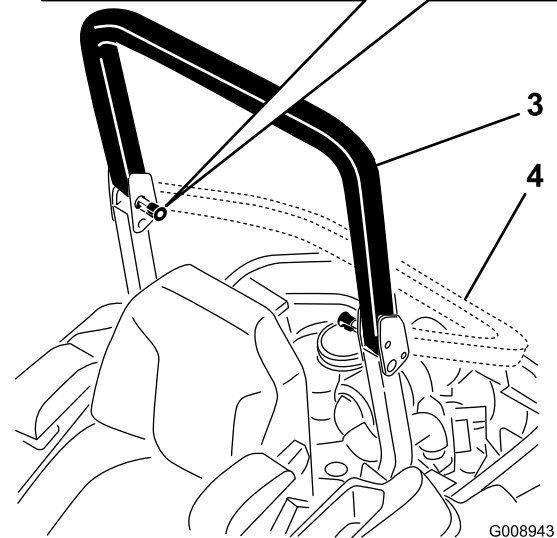
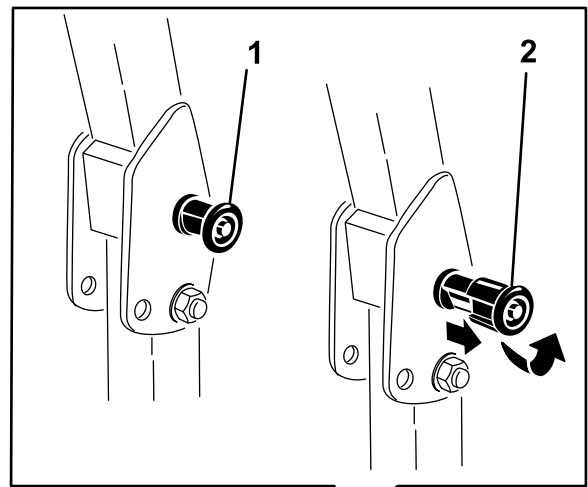

Figure 61

1. ROPS knob (locked position)
2. Pull the ROPS knob out, and rotate it 90 degrees to change the roll bar position
3. Roll bar in the upright position
4. Roll bar in the folded position

Adjusting the Tracking

1. Disengage the blade-control switch (PTO).
2. Drive to an open, flat area, and move the motion-control levers to the neutral-locked position.
3. Move the throttle midway between Fast and Slow.
4. Move both motion-control levers forward until they both hit the stops in the T-slot.
5. Check which way the machine tracks.
6. If it tracks to the right, loosen the bolts and adjust the left stop plate rearward on the left T-slot until the machine tracks straight (Figure 62).
7. If it tracks to the left, loosen the bolts and adjust the right stop plate rearward on the right T-slot until the machine tracks straight (Figure 62).
8. Tighten the stop plate (Figure 62).

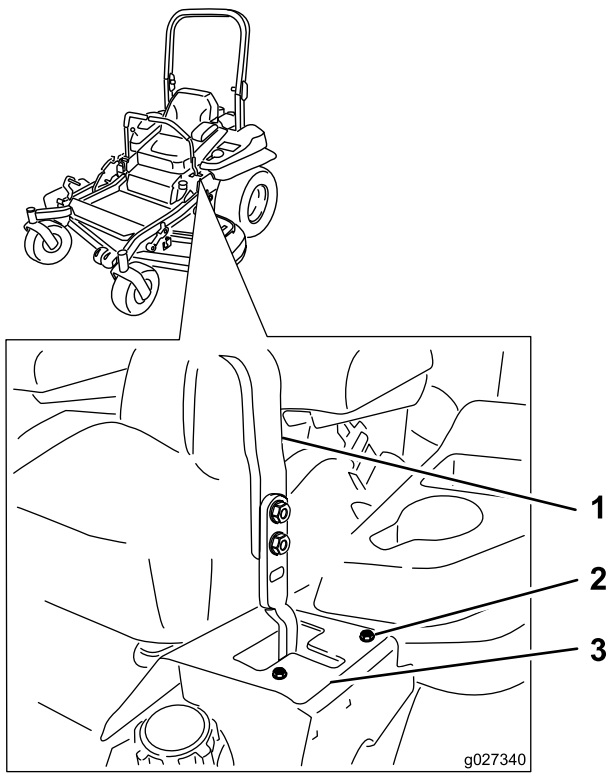

Figure 62

Left control lever shown

- | | |
|------------------|---------------|
| 1. Control lever | 3. Stop plate |
| 2. Bolt | |

Checking the Tire Pressure

Service Interval: Every 50 hours/Monthly (whichever comes first)

Maintain the air pressure in the rear tires at 90 kPa (13 psi). Uneven tire pressure can cause uneven cut. Check the tires when they are cold to get the most accurate pressure reading.

Note: The front tires are semi-pneumatic tires and do not require air pressure maintenance.

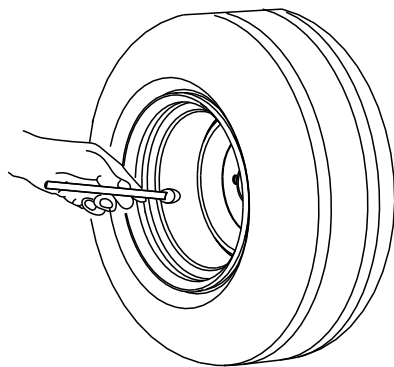

Figure 63

Checking the Wheel Lug Nuts

Check and torque the wheel lug nuts to 122 to 129 N-m (90 to 95 ft-lb).

Checking the Wheel Hub Slotted Nut

Service Interval: After the first 100 hours

Every 500 hours

Check and ensure that the torque of the slotted nut is 286 to 352 N-m (211 to 260 ft-lb).

Note: Do not use anti-seize on wheel hub.

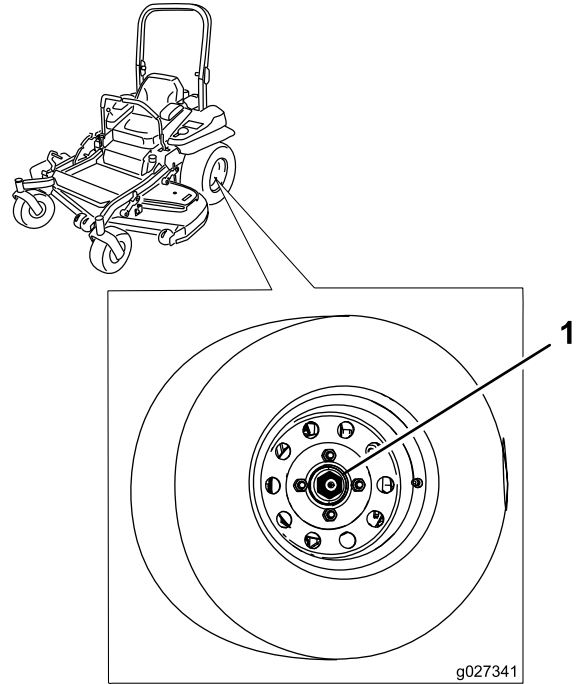

Figure 64

1. Slotted nut

Adjusting the Caster-Pivot Bearing

Service Interval: Every 500 hours/Yearly (whichever comes first)

1. Disengage the blade-control switch (PTO), move the motion-control levers to the neutral-locked position, and set the parking brake.
2. Stop the engine, remove the key, and wait for all moving parts to stop before leaving the operating position.
3. Remove the dust cap from caster and tighten the locknut (Figure 65).
4. Tighten the locknut until the spring washers are flat, and then back off a 1/4 turn to properly set the preload on the bearings (Figure 65).

Important: Make sure that the spring washers are installed correctly as shown in **Figure 65**.

5. Install the dust cap (**Figure 65**).

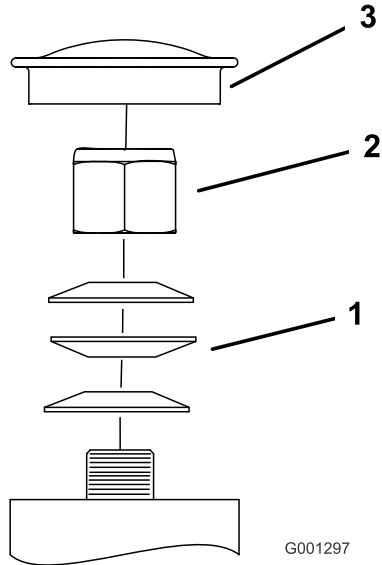

Figure 65

- | | |
|-------------------|-------------|
| 1. Spring washers | 3. Dust cap |
| 2. Lock nut | |

Using the Clutch Shim

Some later model year units have been built with clutches that contain a brake shim. When the clutch brake has worn to the point where the clutch no longer engages consistently, the shim can be removed to extend the clutch life.

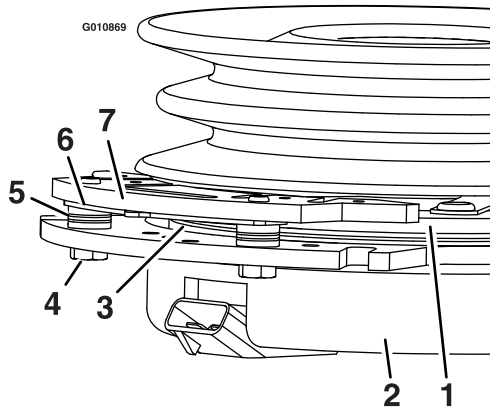

Figure 66

- | | |
|------------------------|-----------------|
| 1. Armature | 5. Brake spacer |
| 2. Field shell | 6. Re-gap shim |
| 3. Rotor | 7. Brake pole |
| 4. Brake-mounting bolt | |

Removing the Clutch Shim

1. Stop the engine, wait for all moving parts to stop, remove the key, engage the parking brake, and allow

the machine to cool completely before starting these instructions.

2. Using an air compressor, blow out any debris from under the brake pole and around the brake spacers.

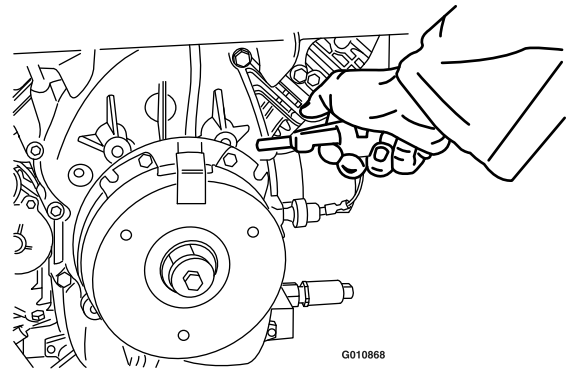

Figure 67

3. Check the condition of the wire-harness leads, connectors, and terminals.

Note: Clean or repair as necessary.

4. Verify that 12V is present at the clutch connector when the PTO switch is engaged.

5. Measure the gap between the rotor and armature. If the gap is greater than 1 mm (0.04 inch), proceed with the following steps:

- A. Loosen both brake-mounting bolts 1/2 to 1 full turn as shown below.

Note: Do not remove the brake pole from the field shell/armature. The brake pole has worn to match the armature and needs to continue to match after the shim is removed to ensure proper brake torque.

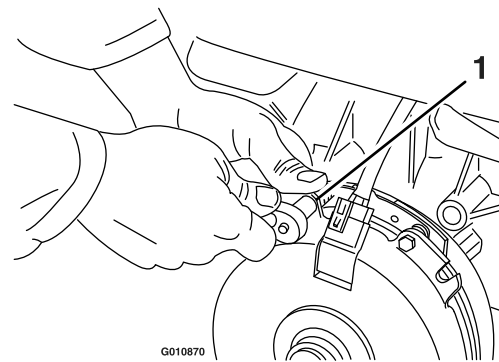

Figure 68

1. Brake-mounting bolt

- B. Using needle-nose pliers, or by hand, hold the tab and remove the shim.

Note: Do not discard the shim until proper clutch function has been confirmed.

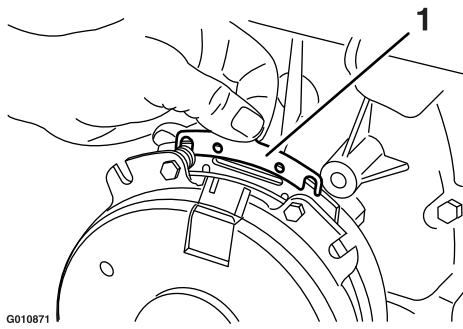

Figure 69

1. Shim

-
- C. Using a pneumatic line, blow out any debris from under the brake pole and around the brake spacers.
 - D. Torque each bolt (M6 x 1) to 13 N-m (10 ft-lb) +/-0.7 N-m (0.5 ft-lb).
 - E. Using a 0.25 mm (0.01 inch) thick feeler gauge, verify that a gap is present between the rotor and the armature face on both sides of the brake pole as shown.

Note: Due to the way the rotor and the armature faces wear (peaks and valleys) it is sometimes difficult to measure the gap accurately.

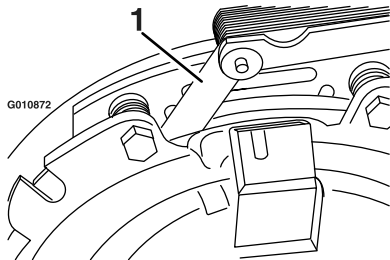

Figure 70

1. Feeler gauge

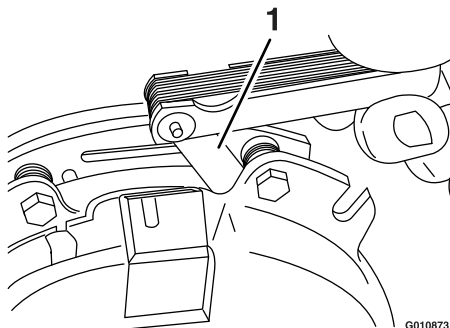

Figure 71

1. Feeler gauge

-
- If the gap is less than 0.25 mm (0.01 inch), then install the shim and refer to .
 - If the gap is sufficient, proceed to the safety check in step F.

F. Perform the following safety check:

- i. Sit on the seat and start the engine.
- ii. Make sure the blades do not engage with the PTO switch in the Off position, and that the clutch is disengaged.

If the clutch does not disengage, install the shim again.

- iii. Engage and disengage the PTO switch 10 consecutive times to ensure that the clutch is functioning properly.

Cooling System Maintenance

Servicing the Engine-Oil Cooler

Service Interval: Every 150 hours

1. To access and service the oil cooler, remove the top mounting screw and loosen the 2 side screws (Figure 72).
2. Remove the shroud (Figure 72).
3. Clean the engine-oil cooler with compressed air (Figure 72).
4. Install the shroud and the screws (Figure 72).

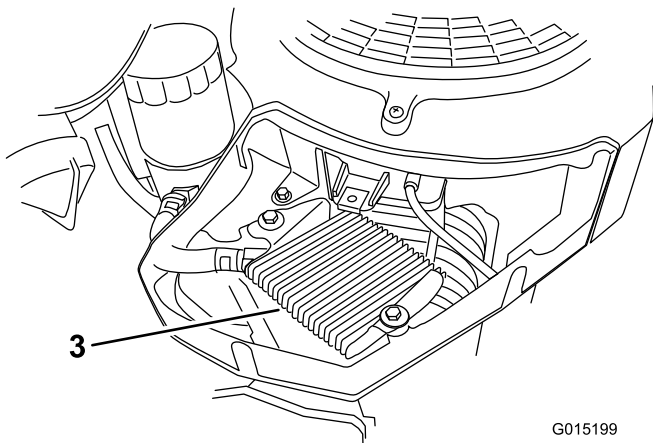
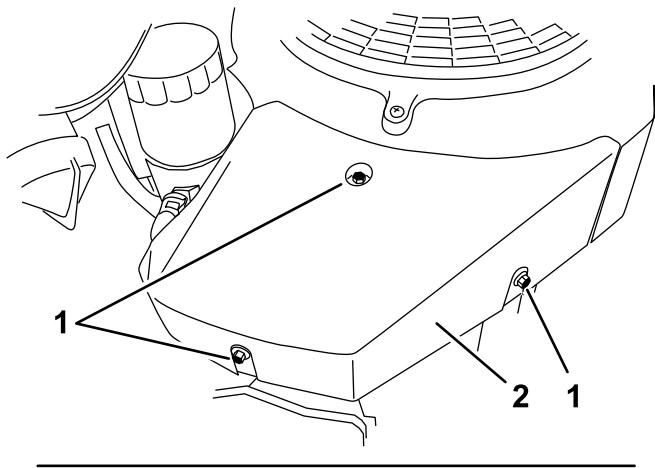

Figure 72

1. Shroud screws
2. Shroud
3. Engine-oil cooler

Cleaning the Engine Screen

Service Interval: Before each use or daily

Before each use, remove any buildup of grass, dirt, or other debris from the engine screen. This will help ensure adequate cooling, correct engine speed, and will reduce the possibility of overheating and mechanical damage to the engine.

Cleaning the Engine-Cooling Fins and Shrouds

Service Interval: Every 150 hours/Yearly (whichever comes first)

1. Disengage the PTO and set the parking brake.
2. Stop the engine, remove the key, and wait for all moving parts to stop before leaving the operating position.
3. Remove the right-hand shroud by removing the top mounting screw and loosening the 2 side screws (Figure 73).

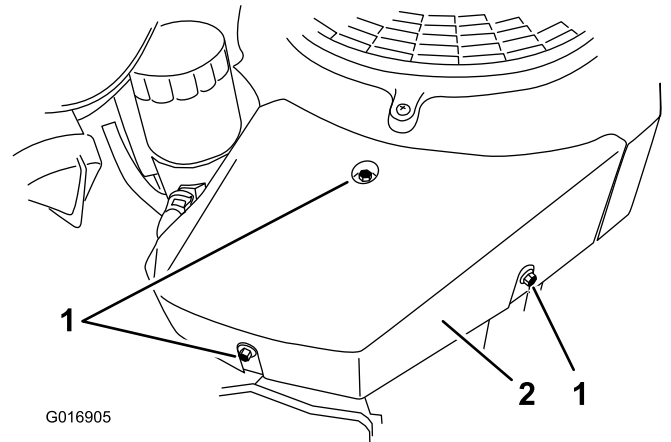

Figure 73

1. Shroud screws
2. Right-hand shroud

4. Remove the top mounting screw and loosen the 2 side screws on the left-hand shroud.
5. Pull up and remove the left-hand shroud, feeding it out around the fuel pump and bracket.
6. Remove the 2 screws on the left and right-hand sides in the cooling-fan housing (Figure 74).

Checking and Cleaning the Hydraulic-Unit Shrouds

Service Interval: Before each use or daily

1. Disengage the PTO and set the parking brake.
2. Stop the engine, remove the key, and wait for all moving parts to stop before leaving the operating position.
3. Move the seat forward.
4. Clean the debris and grass from the hydraulic-unit shrouds (Figure 75).
5. Position the seat.

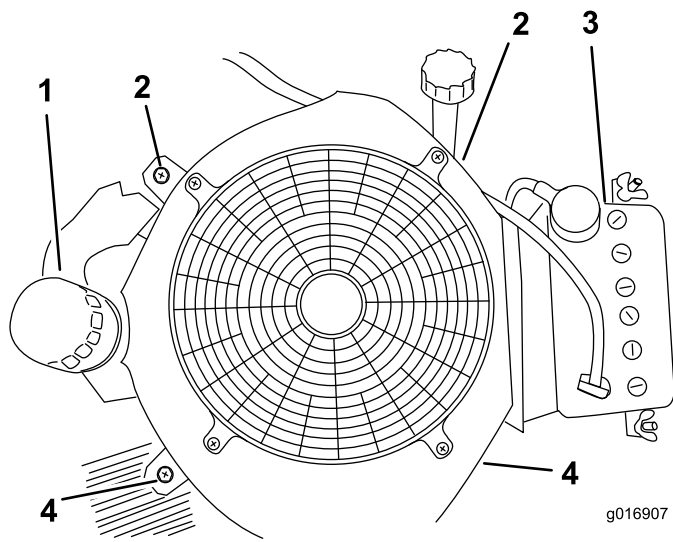
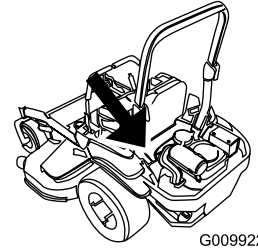

Figure 74

- | | |
|--|---|
| 1. Oil filter | 3. Battery |
| 2. Left side bolts for the cooling-fan housing | 4. Right side bolts for the cooling-fan housing |



7. Remove the cooling-fan housing.
8. Using compressed air, blow out any debris and grass from the engine parts, particularly around the cylinder head cooling fins and ignition coils.
9. Install all of the shrouds onto the engine.

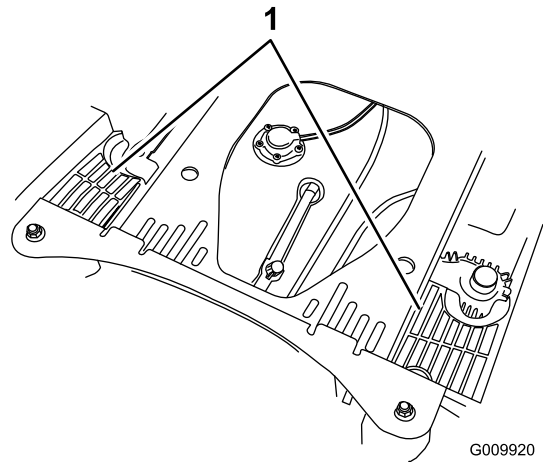

Figure 75

1. Hydraulic-unit shrouds

Brake Maintenance

Adjusting the Parking Brake

Service Interval: After the first 100 hours

Every 500 hours thereafter

Check to make sure the brake is adjusted properly before adjusting.

Note: This procedure must be followed after the first 100 hours or when a brake component has been removed or replaced.

1. Drive the machine onto a level surface.
2. Disengage the blade control switch (PTO), move the motion control levers to the neutral locked position and engage the parking brake.
3. Stop the engine, wait for all moving parts to stop, and remove the key.
4. Raise the back of the machine up and support the machine with jack stands.

⚠ DANGER

Mechanical or hydraulic jacks may fail to support machine and cause a serious injury.

- Use jack stand when supporting machine.
- Do not use hydraulic jacks.

5. Remove the rear tires from the machine.
6. Remove any debris from the brake area.
7. Rotate the drive wheel release handle to the released position. Refer to [Using the Drive-Wheel-Release Valves \(page 29\)](#).
8. Check to see if there is a visible gap between the L-bracket and the linkage stop ([Figure 76](#)).

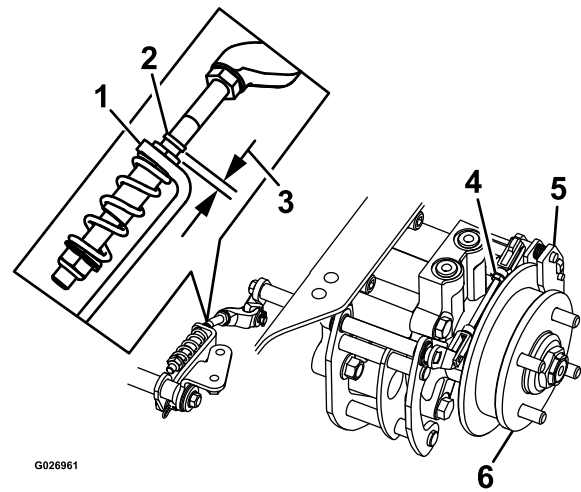

Figure 76
Left Side Shown

1. L-bracket
 2. Linkage stop
 3. Gap
 4. Rear linkage assembly
 5. Caliper
 6. Wheel hub
-
9. Disengage the parking brake, the lever should be in the down position.
 10. Turn the wheel hub by hand in both directions relative to the caliper; the wheel hub should move freely between the caliper.
 11. If a gap is needed or the wheel hub does not move freely:
 - A. Disengage the parking brake.
 - B. Disconnect and fine-tune the rear linkage assembly:
 - Shorten the link to create a gap.
 - Lengthen the link to allow wheel hub movement.
 - C. Reconnect the rear linkage assembly.
 12. Engage the parking brake and check the gap.
 13. Repeat steps 9 through 13 until a visible gap is achieved and the wheel hub rotates freely.
 14. Repeat this procedure for the brake on the opposite side.
 15. Rotate the drive wheel release handle to the operating position. Refer to [Using the Drive-Wheel-Release Valves \(page 29\)](#).
 16. Install the rear tires and torque the lug nuts. Refer to [Checking the Wheel Lug Nuts \(page 46\)](#)
 17. Remove the jack stands.

Belt Maintenance

Inspecting the Belts

Service Interval: Every 50 hours

Check the belts for squealing when the belt is rotating, blades slipping when cutting grass, frayed belt edges, burn marks, and cracks are signs of a worn mower belt. Replace the mower belt if any of these conditions are evident.

Replacing the Mower Belt

Squealing when the belt is rotating, blades slipping when cutting grass, frayed belt edges, burn marks, and cracks are signs of a worn mower belt. Replace the mower belt if any of these conditions are evident.

1. Disengage the PTO, move the motion-control levers to the neutral-locked position, and set the parking brake.
2. Stop the engine, remove the key, and wait for all moving parts to stop before leaving the operating position.
3. Lower the mower to the 76 mm (3 inches) height-of-cut.
4. Remove the belt covers (Figure 77).

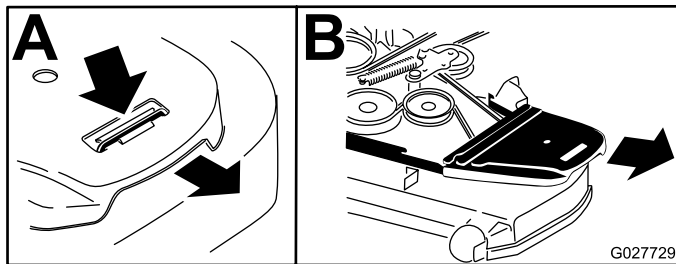

Figure 77

1. Push the tab down
2. Remove the belt cover

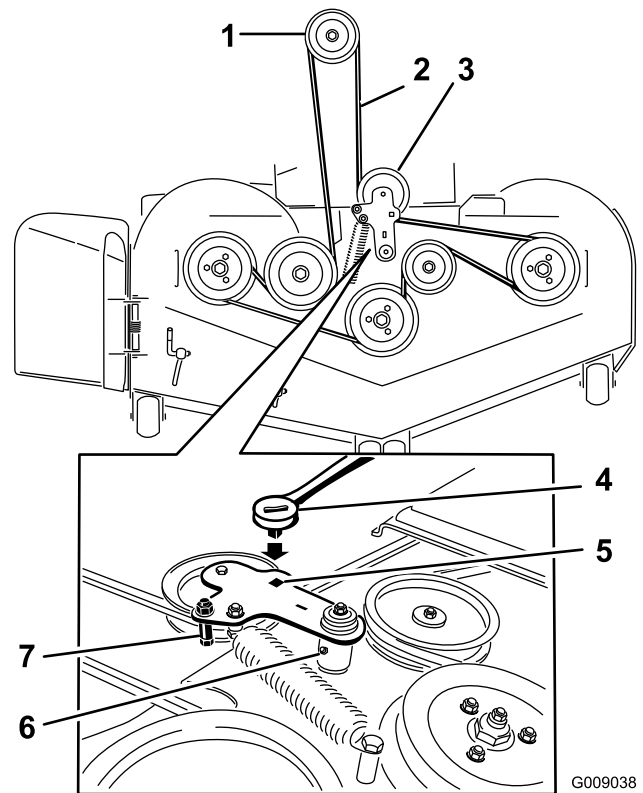

Figure 78

1. Clutch pulley
2. Mower belt
3. Spring-loaded idler pulley
4. Ratchet
5. Square hole in the idler arm for the ratchet
6. Idler-grease fitting
7. Belt guide

10. Install the belt guide on the idler arm (Figure 78).
11. Using the ratchet in the square hole, install the idler spring (Figure 78).

Note: Make sure the spring ends are seated in the anchor grooves.

12. Install the belt covers (Figure 79).

5. Use a ratchet in the square hole in the idler arm to remove tension on the idler spring (Figure 78).
6. Remove the belt from the mower-deck pulleys.
7. Remove the belt guide on the spring-loaded idler arm (Figure 78).
8. Remove the existing belt.
9. Install the new belt around the mower pulleys and the clutch pulley under the engine (Figure 78).

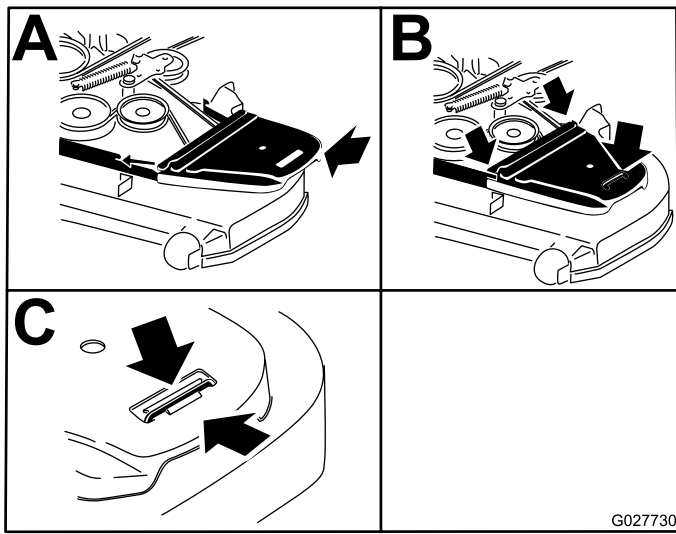

Figure 79

1. Position the belt cover
2. Slide the belt cover under the side catches
3. Ensure that the tab is under the metal catch

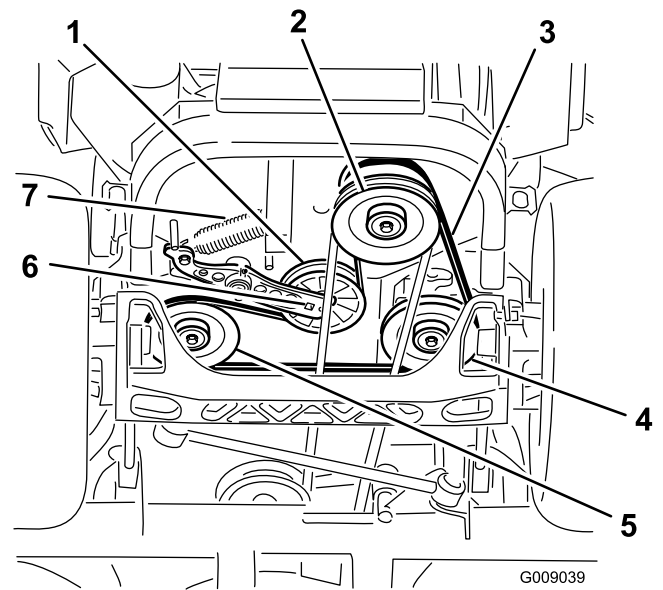

Figure 80

1. Idler pulley
2. Clutch pulley
3. Pump-drive belt
4. Right hand hydraulic-pump pulley
5. Left hand hydraulic-pump pulley
6. Square hole in the idler arm
7. Idler spring

Replacing the Hydraulic Pump-Drive Belt

1. Disengage the PTO and set the parking brake.
2. Stop the engine, remove the key, and wait for all moving parts to stop before leaving the operating position.
3. Remove the mower belt; refer to [Replacing the Mower Belt \(page 52\)](#).
4. Raise the machine and support it with jack stands ([Figure 80](#)).
5. Use a ratchet in the square hole in the idler arm to remove the idler spring ([Figure 80](#)).
6. Unhook the idler spring from the frame ([Figure 80](#)).
7. Remove the belt from the hydraulic unit drive pulleys and the engine pulley.
8. Install the new belt around engine pulley and the 2 drive pulleys.
9. Using a ratchet in the square hole in the idler arm, install the idler spring to the frame ([Figure 80](#)).
10. Install the mower belt; refer to [Replacing the Mower Belt \(page 52\)](#).

Controls System Maintenance

Adjusting the Control-Handle Position

There are 2 height positions for the control levers—high and low. Remove the bolts to adjust the height for the operator.

1. Disengage the PTO, move the motion-control levers to the neutral-locked position, and set the parking brake.
2. Stop the engine, remove the key, and wait for all moving parts to stop before leaving the operating position.
3. Loosen the bolts and flange nuts installed in the levers (Figure 81).
4. Align the levers in the front-to-rear position by bringing the levers together to the neutral position, and slide them until they are aligned, then tighten the bolts (Figure 82).

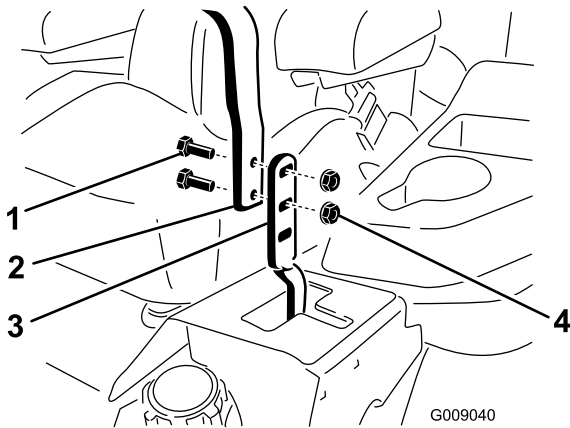

Figure 81

- | | |
|-----------|------------------|
| 1. Bolt | 3. Control lever |
| 2. Handle | 4. Nut |

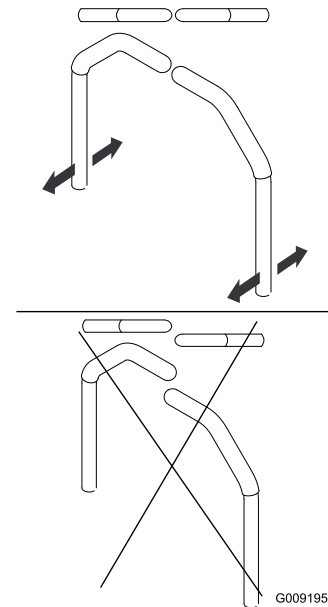

Figure 82

5. If the ends of the levers hit against each other, refer to [Adjusting the Motion Control Neutral-Lock Pivot \(page 56\)](#).
6. Repeat to adjust the control levers.

Adjusting the Motion-Control Linkage

Located on either side of the fuel tank, below the seat are the pump-control linkages. Rotating the pump linkage with a 1/2-inch wrench allows fine tuning adjustments so that the machine does not move in neutral. Any adjustments should be made for neutral positioning only.

⚠ WARNING

Engine must be running and drive wheels must be turning so motion control adjustment can be performed. Contact with moving parts or hot surfaces may cause personal injury.

Keep fingers, hands, and clothing clear of rotating components and hot surfaces.

1. Prior to starting the engine, push the deck-lift pedal, and remove the height-of-cut pin.
2. Lower deck to the ground.
3. Raise the rear of machine up and support it with jack stands (or equivalent support).

Note: Raise the machine just high enough to allow drive wheels to turn freely.

4. Remove the electrical connection from the seat safety switch, located under the bottom cushion of the seat.

Note: The switch is a part of the seat assembly.

5. **Temporarily** install a jumper wire across the terminals in the connector of the main wiring harness.

6. Start the engine and run it at full throttle and release the brake.

Note: The brake must be engaged and the motion-control levers must be out to start the engine. The operator does not have to be in the seat, because of the jumper wire being used.

7. Run the unit for at least 5 minutes with the drive levers at full forward speed to bring the hydraulic oil up to the operating temperature.

Note: The motion-control levers needs to be in neutral while making any necessary adjustments.

8. Bring the motion-control levers into the neutral position.

9. Adjust the pump control rod lengths by rotating the double nuts on the rod in the appropriate direction until the wheels slightly creep in reverse (Figure 83).

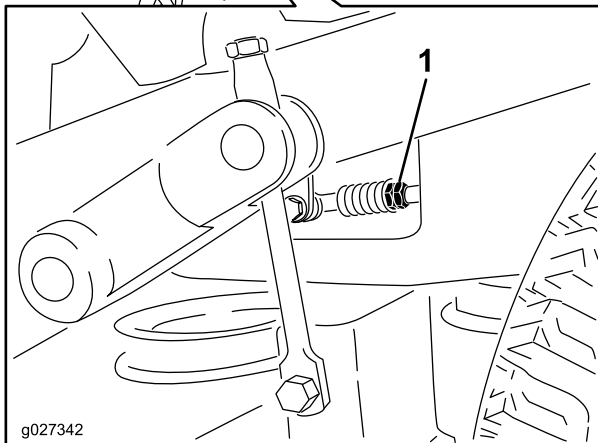
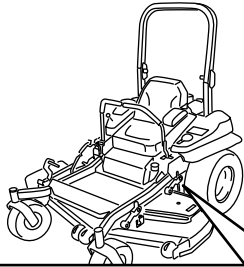

Figure 83

1. Double nuts

10. Move the motion-control levers to the reverse position and while applying slight pressure to the lever, allow the reverse-indicator springs to bring the levers back to neutral.

Note: The wheels must stop turning or slightly creep in reverse.

11. Shut off the unit, remove the jumper wire from the wire harness, and plug the connector into the seat switch.

12. Remove the jack stands.

13. Raise the deck and install the height-of-cut pin.

14. Check that the machine does not creep in neutral with the park brakes disengaged.

Adjusting the Motion-Control Damper

The top damper mounting bolt can be adjusted to obtain a more desired motion-control lever resistance. See Figure 84 for mounting options.

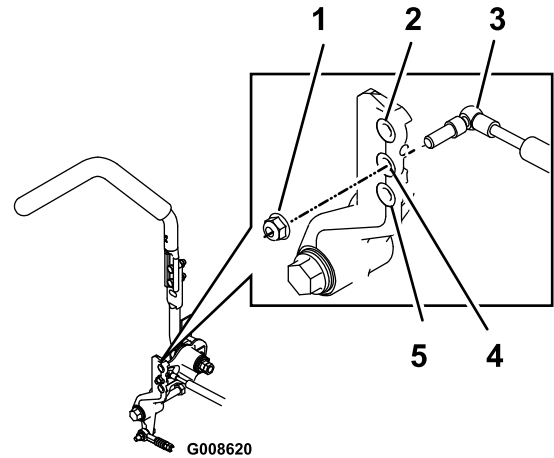

Figure 84

Right-hand control shown

1. Torque the locknut to 23 N-m (17 ft-lb). The bolt must protrude past the end of the locknut after torquing.
2. Most resistance (firmest feel)
3. Damper
4. Medium resistance (medium feel)
5. Least resistance (softest feel)

Adjusting the Motion Control Neutral-Lock Pivot

The flanged nut can be adjusted to obtain a more desired motion-control lever resistance when moving it to the neutral-lock position. See [Figure 85](#) for adjustment options.

1. Loosen the jam nut.
2. Tighten or loosen the flanged nut to the desired feel.

Note: For more resistance, tighten the flanged nut.

Note: For less resistance, loosen the flanged nut

3. Tighten the jam nut.

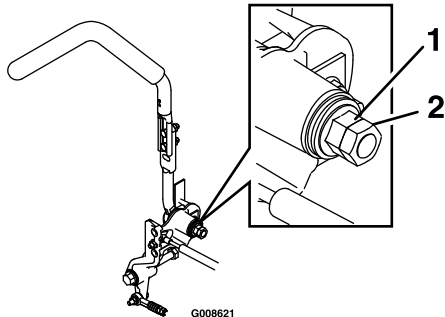

Figure 85

1. Flanged nut

2. Jam nut

Hydraulic System Maintenance

Servicing the Hydraulic System

Hydraulic Oil Type: Toro® HYPR-OIL™ 500 hydraulic oil or Mobil® 1 15W-50.

Important: Use the specified oil. Other fluids could cause system damage.

Each Hydraulic System Oil Capacity: 1.5 L (52 oz) per side with filter change

Checking the Hydraulic Oil

Service Interval: Every 50 hours—Check the hydraulic oil level.

1. Position the machine on a level surface.
2. Disengage the PTO, move the motion-control levers to the neutral-locked position, and set the parking brake.
3. Stop the engine, remove the key, and wait for all moving parts to stop before leaving the operating position.
4. Allow the engine and the hydraulic system to cool for 10 minutes.

Note: The oil level on the dipstick will be incorrect when the oil is checked and the unit is hot.

5. Move the seat forward.
6. Clean the area around the dipsticks of hydraulic-system reservoirs ([Figure 86](#)).
7. Remove one dipstick from the hydraulic reservoir ([Figure 86](#)).
8. Wipe the dipstick off and thread the dipstick into the reservoir.
9. Remove the dipstick and look at the end ([Figure 86](#)).

Important: Do not overfill the hydraulic units with oil as damage may occur. Do not run the machine with the oil below the add mark.

10. If the oil level is at the add mark, slowly pour only enough oil into the hydraulic reservoir to raise the level to the full or **H** line.
11. Install the dipstick.
12. Repeat the procedure for the opposite dipstick.

Replacing the Hydraulic Filters and Hydraulic Oil

Service Interval: After the first 250 hours—Change the hydraulic filters and hydraulic oil when using any type of oil.

Every 250 hours—Change the hydraulic filters and hydraulic oil when using Mobil® 1 oil (more often in dirty or dusty conditions).

Every 500 hours—Change the hydraulic filters and hydraulic oil when using Toro® HYPR-OIL™ 500 hydraulic oil (more often in dirty or dusty conditions).

To replace the hydraulic oil, the filters need to be removed. Replace both at the same time; refer to [Servicing the Hydraulic System](#) (page 56) for the oil specifications.

1. Disengage the blade-control switch (PTO), move the motion-control levers to the neutral-locked position, and set the parking brake.
2. Stop the engine, remove the key, and wait for all moving parts to stop before leaving the operating position.
3. Raise the machine and support it with jack stands ([Figure 87](#)).

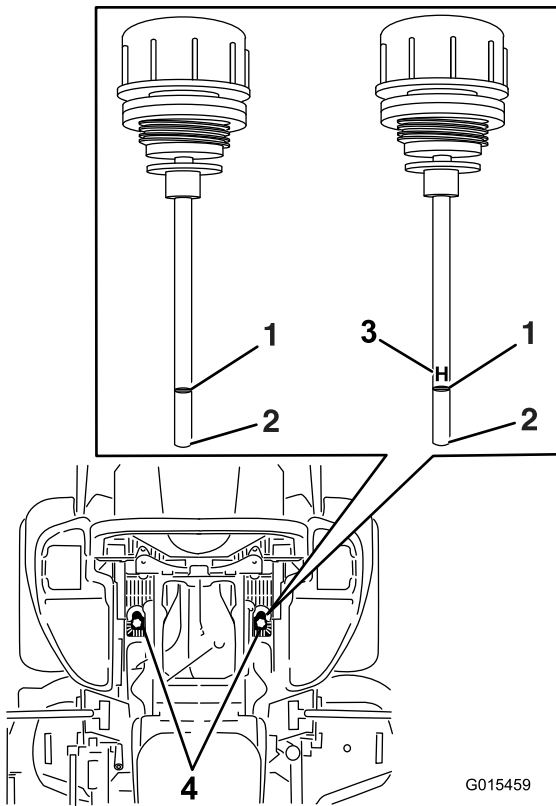

Figure 86

Either dipstick will be used in the machine

1. Full
2. Add
3. H —means high level
4. Dipstick locations under seat

⚠ WARNING

Hydraulic oil escaping under pressure can penetrate skin and cause injury.

- If hydraulic oil is injected into the skin it must be surgically removed within a few hours by a doctor familiar with this type of injury. Gangrene may result if this is not done.
- Keep your body and hands away from pinhole leaks or nozzles that eject high-pressure hydraulic oil.
- Use cardboard or paper to find hydraulic leaks.
- Safely relieve all pressure in the hydraulic system before performing any work on the hydraulic system.
- Make sure all hydraulic-oil hoses and lines are in good condition, and all hydraulic connections and fittings are tight before applying pressure to the hydraulic system.

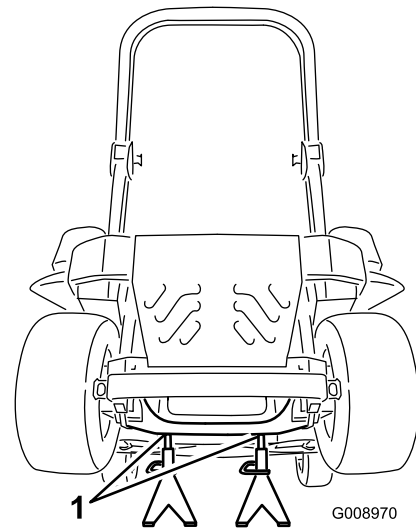

Figure 87

1. Jack stands
 4. Remove both the mower belt and the pump-drive belt; refer to [Replacing the Mower Belt](#) (page 52) and [Replacing the Hydraulic Pump-Drive Belt](#) (page 53).
- Note:** This prevents oil from getting on the belts.
5. Place a drain pan under the filter, remove the old filter, and wipe the surface clean ([Figure 88](#)).

Mower Deck Maintenance

Leveling the Mower Deck

Setting up the Machine

Note: Ensure that the mower deck is leveled before matching the height-of-cut (HOC).

1. Position the mower on a flat surface.
2. Disengage the blade-control switch (PTO), move the motion-control levers to the neutral-locked position, and set the parking brake.
3. Stop the engine, remove the key, and wait for all moving parts to stop before leaving the operating position.
4. Check tire pressure of the drive tires.
5. If needed, adjust to 90 kPa (13 psi).
6. Position the mower to the 76 mm (3 inches) height-of-cut position.

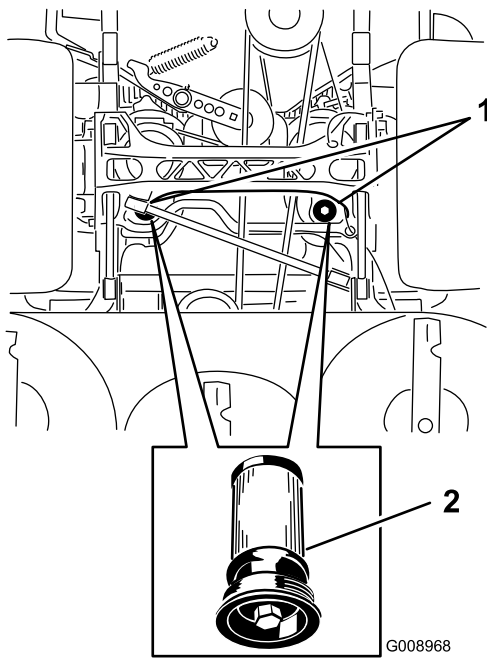

Figure 88

Bottom view of the machine

1. Filter locations
2. Hydraulic filter

6. Apply a thin coat of hydraulic oil to the rubber gasket on the replacement filter (Figure 88).
7. Install the replacement hydraulic filter.
8. Install the pump-drive belt and the mower belt.
9. Remove the jack stands and lower the machine (Figure 87).
10. Add oil to the hydraulic reservoir and check for any leaks.
11. Clean up any spilled oil.
12. Start the engine and let it run for about 2 minutes to purge air from the system.
13. Stop the engine and check for leaks.
14. Check the oil level while the oil is cold.
15. If required, add oil to the hydraulic reservoir.

Note: Do not overfill.

Leveling the Deck

1. Position the mower on a flat surface.
 2. Stop engine, wait for all moving parts to stop, remove the key, and engage the parking brake.
 3. Check the tire pressure in the drive tires.
- Note:** Proper inflation pressure for the tires is 90 kPa (13 psi).
4. Position the transport lock in the latching position.
 5. Push the deck-lift pedal all the way forward and the deck will latch at the 14 cm (5-1/2 inches) transport position (Figure 89).

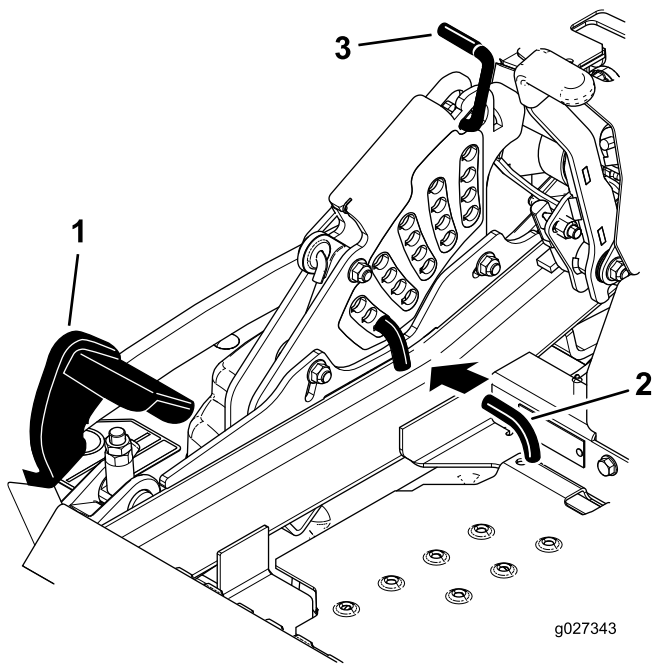

Figure 89

- 1. Deck-lift pedal
- 2. Height-of-cut pin
- 3. Transport lock

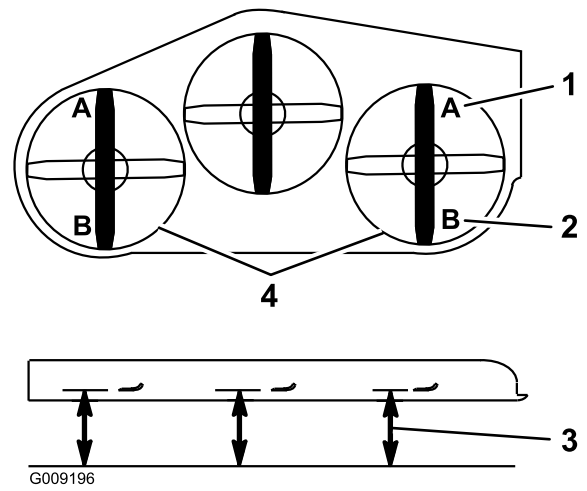

Figure 90

- 1. 7.6 cm (3 inches) at position A is correct
- 2. 8.3 cm (3-1/4 inches) at position B is correct
- 3. Measure here from the blade tip to the hard surface
- 4. Measure at position A and B on both sides

- 6. Insert the height adjustment pin into the 7.6 cm (3 inches) cutting height location.
- 7. Release the transport lock and allow the deck to lower to the cutting height.
- 8. Raise the discharge chute.
- 9. On both sides of the deck, measure from the level surface to the front tip of the blade (Position A) as shown in [Figure 90](#).

Note: The measurement should read 7.6 mm (3 inches)

- 10. For mower decks shown in [Figure 91](#), fine-tune the adjustment nut on the front deck lift assembly by turning it.

Note: To increase the height, turn the adjustment nut clockwise; to decrease, turn it counterclockwise.

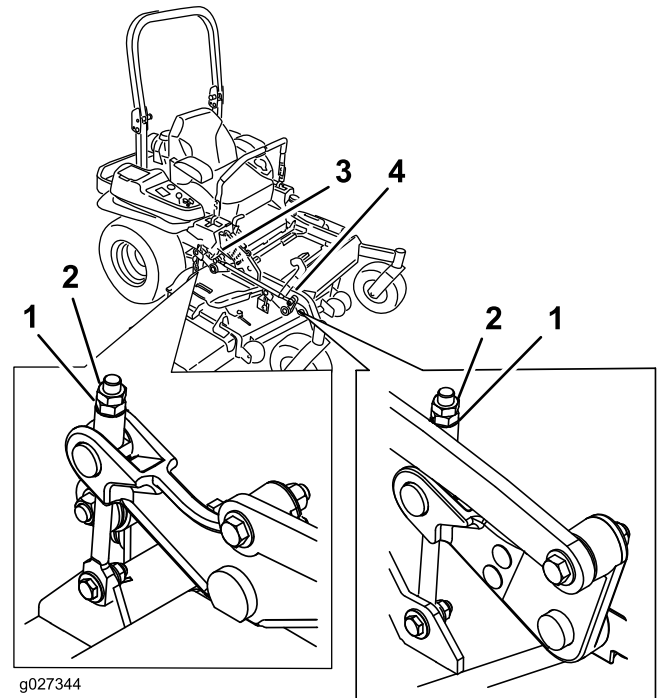

Figure 91

- 1. Adjustment nut
- 2. Jam nut
- 3. Rear deck adjustment
- 4. Front deck adjustment

- 11. For mower decks shown in [Figure 92](#), fine-tune the adjustment nut on the front deck lift assembly by turning it ([Figure 92](#)).

Note: To increase the height, turn the adjustment nut clockwise; to decrease, turn counterclockwise.

Note: If the front deck links do not have enough adjustment to achieve accurate cut height, the single point adjustment can be utilized to gain more adjustment.

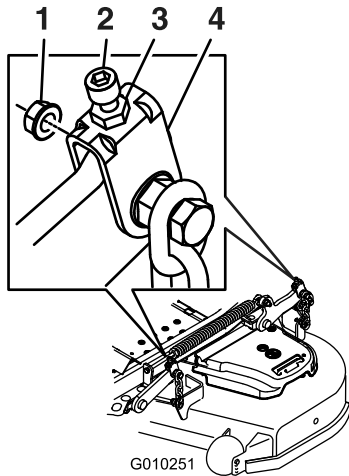

Figure 92

- | | |
|-------------------|--------------------------|
| 1. Adjustment nut | 3. Rear deck adjustment |
| 2. Jam nut | 4. Front deck adjustment |

12. To adjust the single-point system, loosen the 2 bolts at the bottom of the height-of-cut plate (Figure 93).

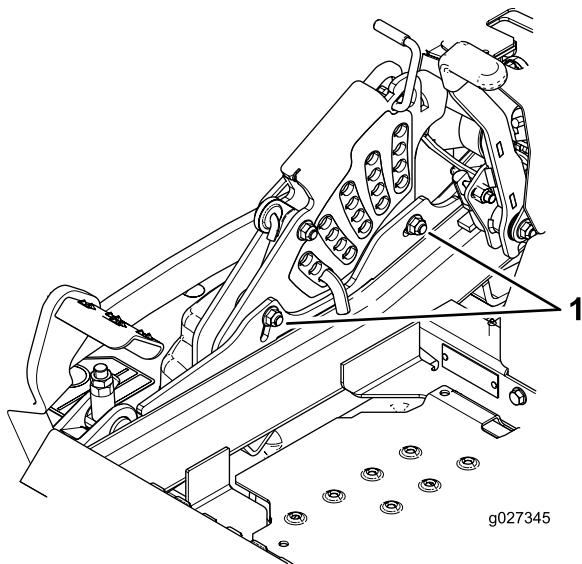

Figure 93

1. Bolts at the bottom of the height-of-cut plate

13. If the deck is too low, tighten the single point adjustment bolt by rotating it clockwise. If the deck is too high, loosen the single point adjustment bolt by rotating it counterclockwise (Figure 94).

Note: Loosen or tighten the single-point adjustment bolt enough to move the height-of-cut plate mounting

bolts at least 1/3 the length of the available travel in their slots. This will regain some up and down adjustment on each of the 4 deck links.

14. Tighten the 2 bolts at the bottom of the height-of-cut plate (Figure 94).

Note: In most conditions, the back blade tip should be adjusted 6.4 mm (1/4 inch) higher than the front.

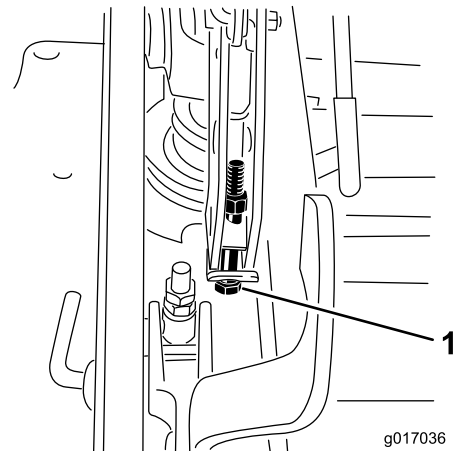

Figure 94

1. Single-point adjustment bolt

15. Torque the 2 bolts to 37 to 45 N-m (27 to 33 ft-lb).

16. On both sides of the deck, measure from the level surface to the back tip of the blade (position B) as shown in Figure 90.

Note: The measurement should read 8.3 cm (3-1/4 inches)

17. Fine tune the screw adjuster by turning it to get 8.3 mm (3-1/4 inches) height (Figure 92).

To increase the height, turn the adjustment nut clockwise; to decrease, turn counterclockwise.

18. Measure until all 4 sides are the correct height.
 19. Tighten all of the nuts on the deck-lift-arm assemblies.
 20. Lower the discharge chute.

Servicing the Cutting Blades

To ensure a superior quality of cut, keep the blades sharp. For convenient sharpening and replacement, you may want to keep extra blades on hand.

⚠ WARNING

A worn or damaged blade can break, and a piece of the blade could be thrown into the operator's or bystanders' area, resulting in serious personal injury or death.

- Inspect the blades periodically for wear or damage.
- Replace a worn or damaged blade.

Before Inspecting or Servicing the Blades

Park the machine on a level surface, disengage the blades and set the parking brake. Turn the ignition key to off. Remove the key, and disconnect the spark plug wires from the spark plugs.

Inspecting the Blades

Service Interval: Before each use or daily

1. Inspect the cutting edges (Figure 95).
2. If the edges are not sharp or have nicks, remove and sharpen the blade; refer to [Sharpening the Blades](#) (page 62).
3. Inspect the blades, especially in the curved area.
4. If you notice any cracks, wear, or a slot forming in this area, immediately install a new blade (Figure 95).

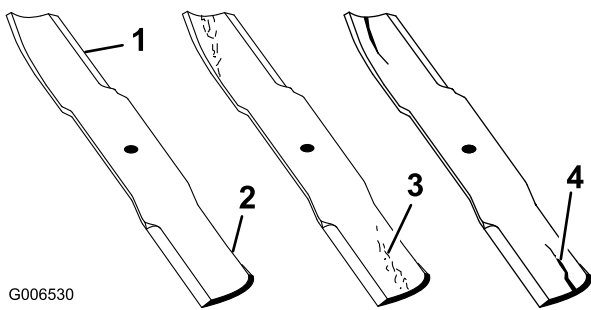

Figure 95

- | | |
|-----------------|----------------------|
| 1. Cutting edge | 3. Wear/slot forming |
| 2. Curved area | 4. Crack |

Checking for Bent Blades

1. Disengage the PTO, move the motion-control levers to the neutral-locked position, and set the parking brake.
2. Stop the engine, remove the key, and wait for all moving parts to stop before leaving the operating position.
3. Rotate the blades until the ends face forward and backward.
4. Measure from a level surface to the cutting edge, position A, of the blades (Figure 96).

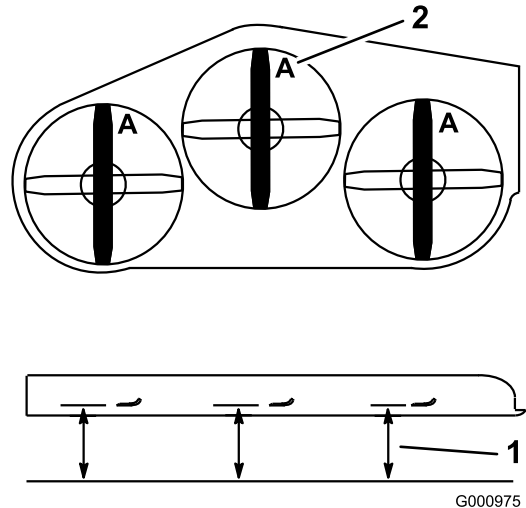

Figure 96

1. Measure here from blade
2. Position A to hard surface

5. Rotate the opposite ends of the blades forward.
6. Measure from a level surface to the cutting edge of the blades at the same position as in step 4 above.

Note: The difference between the dimensions obtained in steps 4 and 5 must not exceed 3 mm (1/8 inch).

Note: If this dimension exceeds 3 mm (1/8 inch), the blade is bent and must be replaced.

⚠ WARNING

A blade that is bent or damaged could break apart and could seriously injure or kill you or bystanders.

- Always replace bent or damaged blade with a new blade.
- Do not file or create sharp notches in the edges or surfaces of the blade.

Removing the Blades

Blades must be replaced if a solid object is hit, if the blade is out of balance, or if the blade is bent. To ensure optimum performance and continued safety conformance of the machine, use genuine Toro replacement blades. Replacement blades made by other manufacturers may result in nonconformance with safety standards.

1. Hold the blade end using a rag or a thickly-padded glove.
2. Remove the blade bolt, the curved washer, and the blade from the spindle shaft (Figure 97).

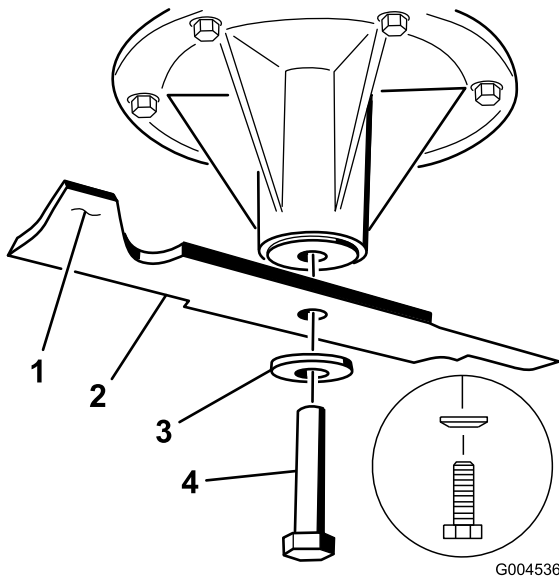

Figure 97

- | | |
|---------------------------|------------------|
| 1. Sail area of the blade | 3. Curved washer |
| 2. Blade | 4. Blade bolt |

Sharpening the Blades

1. Use a file to sharpen the cutting edge at both ends of the blade (Figure 98).

Note: Maintain the original angle.

Note: The blade retains balance if the same amount of material is removed from both cutting edges.

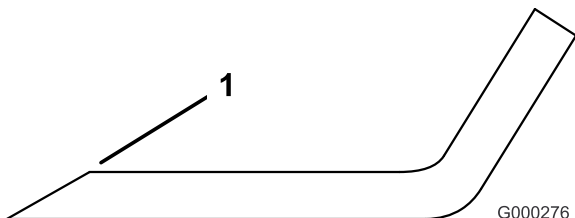

Figure 98

1. Sharpen at the original angle

2. Check the balance of the blade by putting it on a blade balancer (Figure 99).

Note: If the blade stays in a horizontal position, the blade is balanced and can be used.

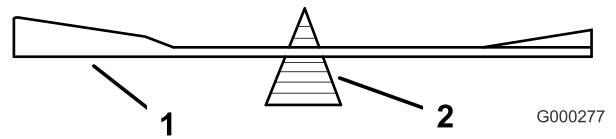

Figure 99

- | | |
|----------|-------------|
| 1. Blade | 2. Balancer |
|----------|-------------|

3. If the blade is not balanced, file some metal off the end of the sail area only (Figure 97).
4. Repeat this procedure until the blade is balanced.

Installing the Blades

1. Install the blade onto the spindle shaft (Figure 100).

Important: The curved part of the blade must be pointing upward toward the inside of the mower to ensure proper cutting.

2. Install the spring disk and blade bolt (Figure 100).

Note: The spring-disk cone must be installed toward the bolt head (Figure 100).

3. Torque the blade bolt to 115 to 150 N-m (85 to 110 ft-lb).

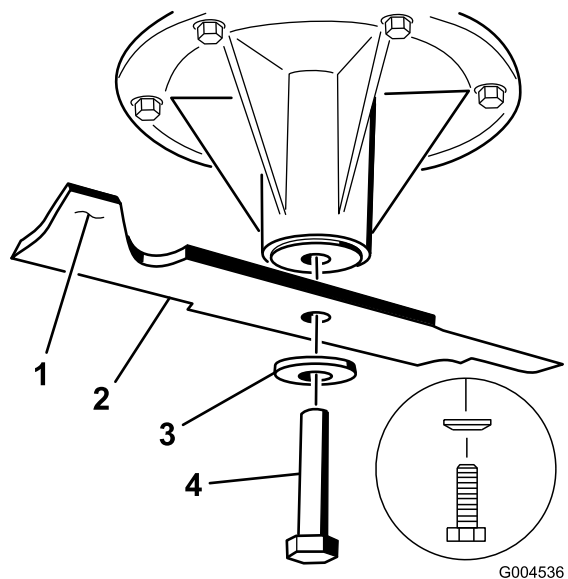

Figure 100

- | | |
|---------------------------|----------------|
| 1. Sail area of the blade | 3. Spring disk |
| 2. Blade | 4. Blade bolt |

Removing the Mower Deck

Before servicing or removing the mower deck, the spring-loaded deck arms must be locked out.

⚠ WARNING

Deck-lift-arm assemblies have stored energy. Removing the deck without releasing the stored energy can cause serious injury or death.

Do not attempt to disassemble the deck from the front frame without locking out the stored energy.

1. Stop the engine, wait for all moving parts to stop, remove the key, and engage the parking brake.
2. Remove the height-adjustment pin and lower the deck to the ground.
3. Place the height-adjustment pin in the 7.6 cm (3 inches) cutting-height location.

Note: This locks the deck-lift arms in the lowest position when the deck is removed and the stored energy in the deck spring is released.

4. Remove the belt covers.
5. Lift up the floor pan and insert a ratchet into the square hole in the deck idler ([Figure 101](#)).
6. Rotate the deck idler clockwise and remove the mower belt ([Figure 101](#)).

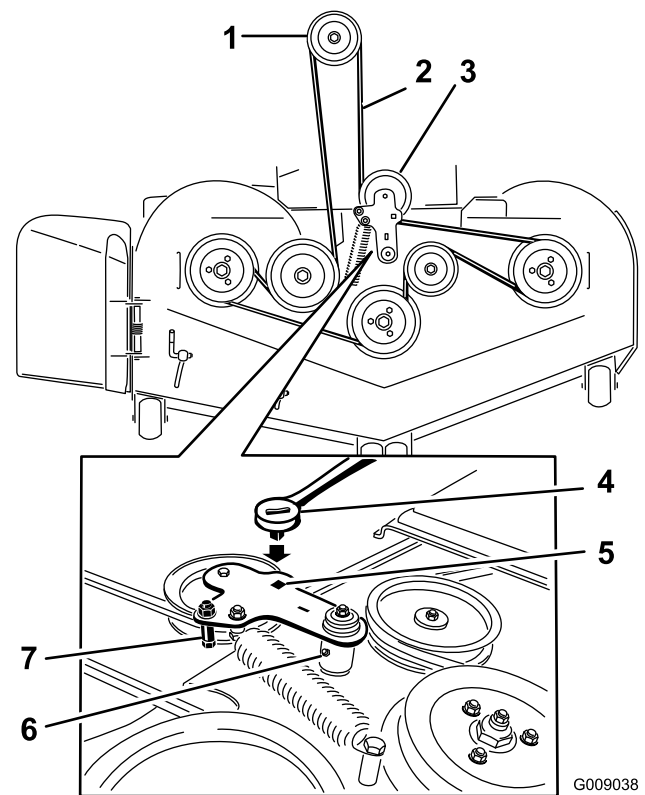

Figure 101

- | | |
|-------------------------------|---|
| 1. Clutch pulley | 5. Square hole in the idler arm for the ratchet |
| 2. Mower belt | 6. Idler grease fitting |
| 3. Spring-loaded idler pulley | 7. Belt guide |
| 4. Ratchet | |

7. Remove and retain the hardware on both sides of the deck ([Figure 102](#)).

Replacing the Grass Deflector

⚠ WARNING

An uncovered discharge opening could allow the lawn mower to throw objects in the operator's or bystander's direction and result in serious injury. Also, contact with the blade could occur.

Do not operate the lawn mower unless you install a cover plate, a mulch plate, grass deflector or bagger.

1. Remove the locknut, the bolt, the spring, and the spacer holding the deflector to the pivot brackets (Figure 103).
2. Remove the damaged or worn grass deflector (Figure 103).

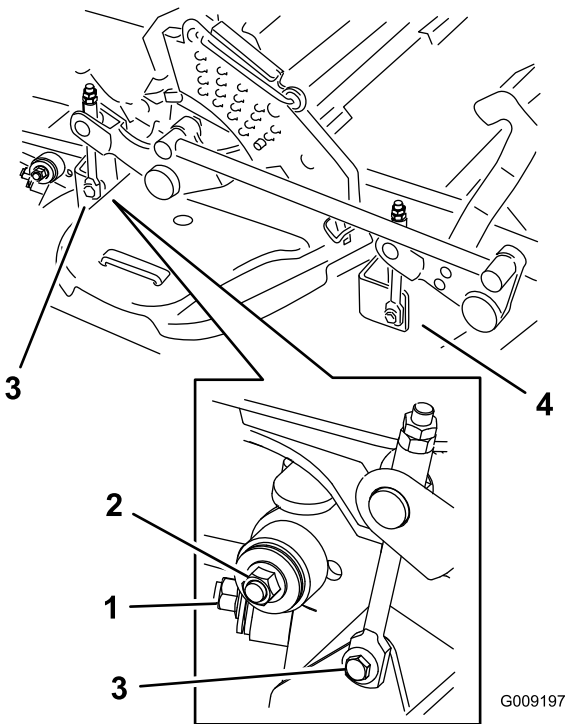

Figure 102

1. Right stabilizer
2. Deck strut (right side shown)
3. Remove the rear deck-lift attachment shoulder bolt and nut.
4. Remove the front deck-lift attachment shoulder bolt and nut.

8. Raise the deck struts and secure them in the up position.
9. Slide the deck out to the right side of the machine.

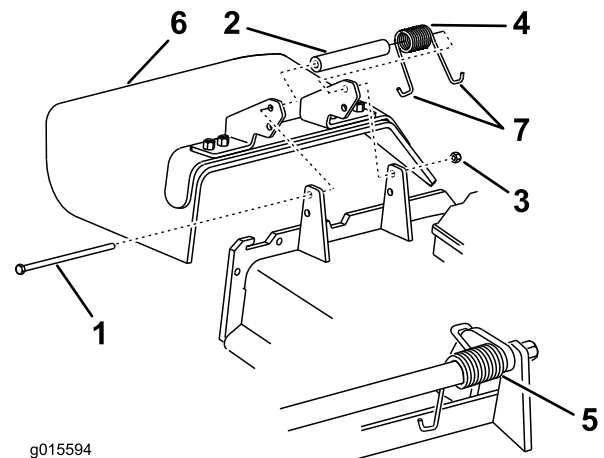

Figure 103

- | | |
|------------|-------------------------|
| 1. Bolt | 5. Spring installed |
| 2. Spacer | 6. Grass Deflector |
| 3. Locknut | 7. J-hook end of spring |
| 4. Spring | |

3. Place the spacer and the spring onto grass deflector.
4. Place 1 J-end of the spring behind the deck edge.

Note: Make sure 1 J-end of the spring is installed behind the deck edge before installing the bolt as shown in Figure 103.

5. Install the bolt and the nut.
6. Place one J-hook end of the spring around the grass deflector (Figure 103).

Important: The grass deflector must be able to rotate. Lift the deflector up to the full open position and ensure that it rotates into the full down position.

Cleaning

Cleaning under the Mower

Service Interval: Before each use or daily

1. Disengage the blade-control switch (PTO), move the motion-control levers to the neutral-locked position, and set the parking brake.
2. Stop the engine, remove the key, and wait for all moving parts to stop before leaving the operating position.
3. Raise the mower to the transport position.

Disposing of Waste

Engine oil, batteries, hydraulic oil, and engine coolant are pollutants to the environment. Dispose of these according to your state and local regulations.

Storage

Cleaning and Storing the Machine

1. Disengage the power-take off (blade-control switch (PTO), set the parking brake, and turn the ignition key to the Off position, and remove the key.
2. Remove grass clippings, dirt, and grime from the external parts of the entire machine (especially the engine and hydraulic system). Clean dirt and chaff from the outside of the engine-cylinder-head fins and the blower housing.

Important: You can wash the machine with mild detergent and water. Do not pressure wash the machine. Avoid excessive use of water, especially near the control panel, engine, hydraulic pumps, and motors.

3. Check the brake; refer to [Brake Maintenance \(page 51\)](#).
4. Service the air cleaner; refer to [Servicing the Air Cleaner \(page 36\)](#).
5. Grease the machine; refer to [Lubrication \(page 34\)](#).
6. Change the crankcase oil; refer to [Changing the Engine Oil \(page 39\)](#).
7. Check the tire pressure; refer to [Checking the Tire Pressure \(page 46\)](#).
8. Change the hydraulic filters; refer to [Replacing the Hydraulic Filters and Hydraulic Oil \(page 57\)](#).
9. Charge the battery; refer to [Servicing the Battery \(page 43\)](#).
10. Scrape any heavy buildup of grass and dirt from the underside of the mower, then wash the mower with a garden hose.

Note: Run the machine with the blade-control switch (PTO) engaged and the engine at high idle for 2 to 5 minutes after washing.

11. Check the condition of the blades; refer to [Servicing the Cutting Blades \(page 61\)](#).
12. Prepare the machine for storage when non-use occurs over 30 days. Prepare the machine for storage as follows:
 - A. Add a petroleum based stabilizer/conditioner to fuel in the tank. Follow mixing instructions from the stabilizer manufacturer. Do not use an alcohol based stabilizer (ethanol or methanol).

Note: A fuel stabilizer/conditioner is most effective when mixed with fresh fuel and used at all times.

- B. Run the engine to distribute conditioned fuel through the fuel system (5 minutes).

- C. Stop the engine, allow it to cool, and drain the fuel tank; refer to [Servicing the Fuel Tank \(page 42\)](#).
- D. Restart the engine and run it until it stops.
- E. Dispose of fuel properly. Recycle as per local codes.

Important: Do not store stabilizer/conditioned fuel over 90 days.

- 13. Check and tighten all bolts, nuts, and screws. Repair or replace any part that is damaged.
- 14. Paint all scratched or bare metal surfaces. Paint is available from your Authorized Service Dealer.
- 15. Store the machine in a clean, dry garage or storage area. Remove the key from the ignition switch and keep it out of reach of children or other unauthorized users. Cover the machine to protect it and keep it clean.

Troubleshooting

Problem	Possible Cause	Corrective Action
The oil-temperature light is on and the engine rpm is low.	1. The engine-control unit has limited engine rpm, known as "limp" mode.	1. Check the engine-oil level. If the level is above the "add" line, contact an Authorized Toro Service Dealer.
The oil-pressure light is on and the engine rpm is low.	1. The engine-control unit has limited engine rpm, known as "limp" mode.	1. Let the engine cool and check the engine-oil level. If the level is above the "add" line, contact an Authorized Toro Service Dealer.
The malfunction-indicator light (MIL) comes on.	<ol style="list-style-type: none"> 1. The engine is too hot. 2. There is old gas in the gas tank. 3. The fuel-shutoff valve is not open completely. 4. The air cleaner is dirty. 5. The battery is not charged. 6. Incorrect fuel filters are being used or dirty fuel filters. 7. The connections to sensors electronic control unit (ECU) and fuel injectors are not secured properly. 8. The battery has low voltage. 9. The fuse is blown. 	<ol style="list-style-type: none"> 1. Turn the engine off and let it cool. 2. Use new gas. 3. Open the fuel-shutoff valve. 4. Make sure that the air cleaner and precleaner are clean. Replace if necessary. 5. Charge or replace the battery. 6. Contact an Authorized Service Dealer. 7. Contact an Authorized Service Dealer. 8. Ensure that a good 12 volt battery is being used and is fully charged. 9. Check and replace any blown fuses.
The starter does not crank.	<ol style="list-style-type: none"> 1. The blade control switch (PTO) is engaged. 2. The parking brake is not on. 3. The drive levers are not in neutral lock position. 4. The operator is not seated. 5. The battery is dead. 6. The electrical connections are corroded or loose. 7. The fuse is blown. 8. The relay or switch is defective. 	<ol style="list-style-type: none"> 1. Move the blade control switch (PTO) to disengaged. 2. Set the parking brake. 3. Ensure that the drive levers are in the neutral lock position. 4. Sit on the seat. 5. Charge the battery. 6. Check the electrical connections for good contact. 7. Replace the fuse. 8. Contact an Authorized Service Dealer.

Problem	Possible Cause	Corrective Action
The engine does not start, starts hard, or fails to keep running.	<ol style="list-style-type: none"> 1. The fuel tank is empty. 2. The fuel shutoff valve is closed. 3. The oil level in the crankcase is low. 4. The throttle is not in the correct position. 5. There is dirt in fuel filter. 6. There is dirt, water, or stale fuel in the fuel system. 7. The air cleaner is dirty. 8. The seat switch is not functioning properly. 9. The electrical connections are corroded, loose or faulty. 10. The relay or switch is defective. 11. The spark plug is faulty. 12. The spark plug wire is not connected. 	<ol style="list-style-type: none"> 1. Fill the fuel tank. 2. Open the fuel shutoff valve. 3. Add oil to the crankcase. 4. Be sure that the throttle control is midway between the "SLOW" and "FAST" positions. 5. Replace the fuel filter. 6. Contact an Authorized Service Dealer. 7. Clean or replace the air cleaner element. 8. Check the seat switch indicator. Replace the seat if needed. 9. Check the electrical connections for good contact. Clean the connector terminals thoroughly with electrical contact cleaner, apply dielectric grease, and reconnect. 10. Contact an Authorized Service Dealer. 11. Clean, adjust, or replace spark plug. 12. Check the spark plug wire connection.
The engine loses power.	<ol style="list-style-type: none"> 1. The oil pressure is low. 2. The oil temperature is high. 3. The engine load is excessive. 4. The air cleaner is dirty. 5. The oil level in the crankcase is low. 6. The cooling fins and air passages above the engine are plugged. 7. The vent hole in the fuel cap is plugged. 8. There is dirt in the fuel filter. 9. There is dirt, water, or stale fuel is in the fuel system. 	<ol style="list-style-type: none"> 1. Check the engine-oil level. If the level is above the "add" line, contact an Authorized Toro Service Dealer. 2. Let the engine cool and check the engine-oil level. If the level is above the "add" line, contact an Authorized Toro Service Dealer. 3. Reduce the ground speed. 4. Clean the air cleaner element. 5. Add oil to the crankcase. 6. Remove the obstruction from the cooling fins and air passages. 7. Clean or replace the fuel cap. 8. Replace the fuel filter. 9. Contact an Authorized Service Dealer.
The engine overheats.	<ol style="list-style-type: none"> 1. The engine load is excessive. 2. The oil level in the crankcase is low. 3. The cooling fins and air passages above the engine are plugged. 	<ol style="list-style-type: none"> 1. Reduce the ground speed. 2. Add oil to the crankcase. 3. Remove the obstruction from the cooling fins and air passages.
The mower pulls left or right (with levers fully forward).	<ol style="list-style-type: none"> 1. The tracking needs adjustment. 2. The tire pressure in the drive tires is not correct. 	<ol style="list-style-type: none"> 1. Adjust the tracking. 2. Adjust the tire pressure in the drive tires.
The machine does not drive.	<ol style="list-style-type: none"> 1. The bypass valves are not closed tight. 2. The pump belt is worn, loose or broken. 3. The pump belt is off a pulley. 4. The idler spring is broken or missing. 5. The hydraulic oil level is low or too hot. 	<ol style="list-style-type: none"> 1. Tighten the by pass valves. 2. Change the belt. 3. Change the belt. 4. Replace the spring. 5. Add hydraulic oil to reservoirs or let it cool down.

Problem	Possible Cause	Corrective Action
There is an abnormal vibration.	<ol style="list-style-type: none"> 1. The cutting blade(s) is/are bent or unbalanced. 2. The blade mounting bolt is loose. 3. The engine mounting bolts are loose. 4. The engine pulley, idler pulley, or blade pulley is loose. 5. The engine pulley is damaged. 6. The blade spindle is bent. 7. The motor mount is loose or worn. 	<ol style="list-style-type: none"> 1. Install new cutting blade(s). 2. Tighten the blade mounting bolt. 3. Tighten the engine mounting bolts. 4. Tighten the appropriate pulley. 5. Contact an Authorized Service Dealer. 6. Contact an Authorized Service Dealer. 7. Contact an Authorized Service Dealer.
Mowing is resulting in uneven cutting height.	<ol style="list-style-type: none"> 1. The blade(s) is/are not sharp. 2. The cutting blade(s) is/are bent. 3. The mower deck is not level. 4. The underside of mower is dirty. 5. The tire pressure is not correct. 6. The blade spindle bent. 	<ol style="list-style-type: none"> 1. Sharpen the blade(s). 2. Install new cutting blade(s). 3. Level the mower deck from side-to-side and front-to-rear. 4. Clean the underside of the mower. 5. Adjust the tire pressure. 6. Contact an Authorized Service Dealer.
The blades do not rotate.	<ol style="list-style-type: none"> 1. The mower deck belt is worn, loose or broken. 2. The mower deck belt is off pulley. 3. The pump drive belt is worn, loose or broken. 4. The idler spring is broken or missing. 	<ol style="list-style-type: none"> 1. Install a new deck belt. 2. Install the mower deck pulley and check the idler pulley, idler arm, and spring for correct position and function. 3. Check the belt tension or install a new belt. 4. Replace the spring.
The clutch does not engage.	<ol style="list-style-type: none"> 1. A fuse is blown. 2. There is low voltage supply at the clutch. 3. The coil is damaged. 4. There is inadequate current supply. 5. The rotor/armature airgap is too large. 	<ol style="list-style-type: none"> 1. Replace the fuse. Check the coil resistance, battery charge, charging system, and wiring connections and replace if necessary. 2. Check the coil resistance, battery charge, charging system, and wiring connections and replace if necessary. 3. Replace the clutch. 4. Repair or replace the clutch lead wire or electrical system. Clean the connector contacts. 5. Remove the shim or replace the clutch.

Schematics

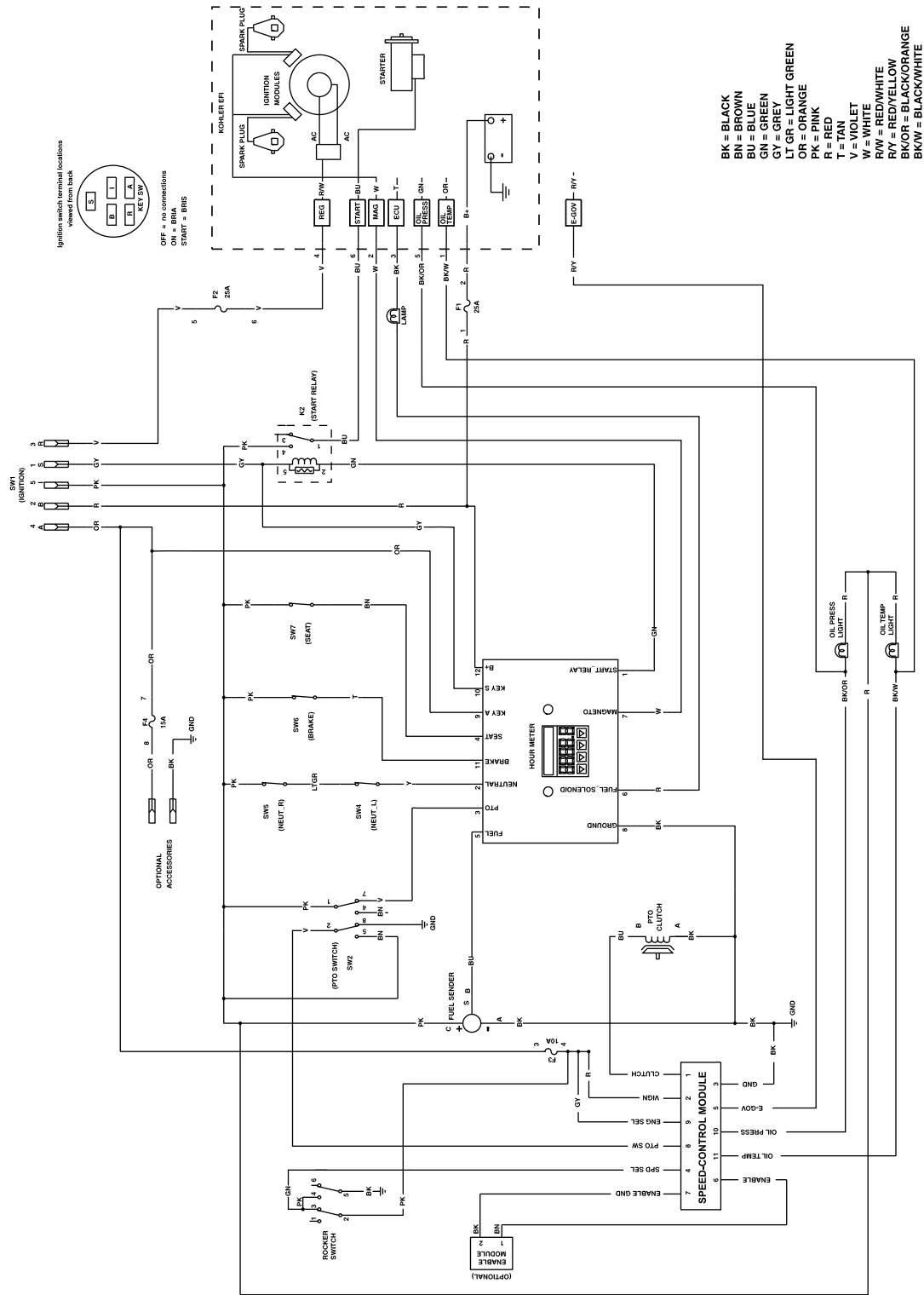

g024363

Electrical Schematic (Rev. A)

Notes:



The Toro Total Coverage Warranty

A Limited Warranty (see warranty periods below)

Landscape
Contractor
Equipment
(LCE)

Conditions and Products Covered

The Toro Company and its affiliate, Toro Warranty Company, pursuant to an agreement between them, jointly promise to the original purchaser to repair the Toro Products listed below if defective in materials or workmanship.

The following time periods apply from the date of purchase by the original owner:

Products	Warranty Period
21 in. Mowers	2 years Residential Use ¹ 1 year Commercial Use
• Engines ⁴	Honda – 2 years Kawasaki – 3 years
30 in. Mowers	2 years Residential Use ¹ 1 year Commercial Use
• Engines ⁴	Kawasaki – 3 years
Mid-Size Walk-Behind Mowers	2 years
• Engines ⁴	Kawasaki – 3 years
Grand Stand® Mowers	5 years or 1,200 hours ² 3 years
• Engines ⁴	Lifetime (original owner only) ³
• Frame	
Z Master® 2000 Series Mowers	4 years or 500 hours ² 3 years
• Engines ⁴	Lifetime (original owner only) ³
• Frame	
Z Master® 3000 Series Mowers	5 years or 1,200 hours ² 3 years
• Engines ⁴	Lifetime (original owner only) ³
• Frame	
Z Master® 5000 Series Mowers	5 years or 1,200 hours ²
• Engines ⁴	Kohler Command – 2 years Kohler EFI – 3 years
• Frame	Lifetime (original owner only) ³
Z Master® 6000 Series Mowers	5 years or 1,200 hours ²
• Engines ⁴	Kawasaki – 3 years
• Frame	Lifetime (original owner only) ³
Z Master® 7000 Series Mowers	5 years or 1,200 hours ² 2 years
• Engines ⁴	Lifetime (original owner only) ³
• Frame	
Z Master® 8000 Series Mowers	2 years or 1,200 hours ² 2 years
• Engines ⁴	Lifetime (original owner only) ³
• Frame	
All Mowers	
• Battery	90 days Parts and Labor 1 year Parts only
• Belts and Tires	90 days
• Attachments	1 year

¹Residential use means use of the product on the same lot as your home. Use at more than one location is considered commercial use and the commercial warranty would apply.

²Whichever occurs first.

³Lifetime Frame Warranty - If the main frame, consisting of the parts welded together to form the tractor structure that other components such as the engine are secured to, cracks or breaks in normal use, it will be repaired or replaced, at Toro's option, under warranty at no cost for parts and labor. Frame failure due to misuse or abuse and failure or repair required due to rust or corrosion are not covered.

⁴Some engines used on Toro Products are warranted by the engine manufacturer.

Instructions for Obtaining Warranty Service

If you think that your Toro Product contains a defect in materials or workmanship, follow this procedure:

1. Contact any Authorized Toro Service Dealer to arrange service at their dealership. To locate a dealer convenient to you, refer to the Yellow Pages of your telephone directory (look under "Lawn Mowers") or access our web site at www.Toro.com. You may also call the numbers listed in item #3 to use the 24-hour Toro Dealer locator system.
2. Bring the product and your proof of purchase (sales receipt) to the Service Dealer. The dealer will diagnose the problem and determine if it is covered under warranty.
3. If for any reason you are dissatisfied with the Service Dealer's analysis or with the assistance provided, contact us at:

RLC Customer Care Department
Toro Warranty Company
8111 Lyndale Avenue South
Bloomington, MN 55420-1196
888-865-5676 (U.S. Customers)
888-865-5691 (Canada customers)

Owner Responsibilities

You must maintain your Toro Product by following the maintenance procedures described in the *Operator's Manual*. Such routine maintenance, whether performed by a dealer or by you, is at your expense.

Items and Conditions Not Covered

There is no other express warranty except for special emission system coverage and engine warranty coverage on some products. This express warranty does not cover the following:

- Cost of regular maintenance service or parts, such as filters, fuel, lubricants, oil changes, spark plugs, air filters blade sharpening or worn blades, cable/linkage adjustments, or brake and clutch adjustments
- Components failing due to normal wear
- Any product or part which has been altered or misused or neglected and requires replacement or repair due to accidents or lack of proper maintenance
- Pickup and delivery charges
- Repairs or attempted repairs by anyone other than an Authorized Toro Service Dealer
- Repairs necessary due to failure to follow recommended fuel procedure (consult *Operator's Manual* for more details)
 - Removing contaminants from the fuel system is not covered
 - Use of old fuel (more than one month old) or fuel which contains more than 10% ethanol or more than 15% MTBE
 - Failure to drain the fuel system prior to any period of non-use over one month

General Conditions

All repairs covered by these warranties must be performed by an Authorized Toro Service Dealer using Toro approved replacement parts.

Neither The Toro Company nor Toro Warranty Company is liable for indirect, incidental or consequential damages in connection with the use of the Toro Products covered by this warranty, including any cost or expense of providing substitute equipment or service during reasonable periods of malfunction or non-use pending completion of repairs under this warranty.

All implied warranties of merchantability (that the product is fit for ordinary use) and fitness for use (that the product is fit for a particular purpose) are limited to the duration of the express warranty.

Some states do not allow exclusions of incidental or consequential damages, or limitations on how long an implied warranty lasts, so the above exclusions and limitations may not apply to you.

This warranty gives you specific legal rights, and you may also have other rights which vary from state to state.

Countries Other than the United States or Canada

Customers who have purchased Toro products outside the United States or Canada should contact their Toro Distributor (Dealer) to obtain guarantee policies for your country, province, or state. If for any reason you are dissatisfied with your Distributor's service or have difficulty obtaining guarantee information, contact the Toro importer. If all other remedies fail, you may contact us at Toro Warranty Company.

Australian Consumer Law: Australian customers will find details relating to the Australian Consumer Law either inside the box or at your local Toro Dealer.