



## ProLine String Trimmer

Model No. 53002 — 7900001 & Up

Model No. 53003 — 7900001 & Up

Model No. 53010 — 7900001 & Up

Model No. 53011 — 7900001 & Up

*PROTOTYPE*

**Operator's Manual**

**WARNING:**

The engine exhaust from this product contains chemicals known to the State of California to cause cancer, birth defects, or other reproductive harm.

**AVERTISSEMENT:**

Les gaz d'échappement du moteur de ce produit contiennent des produits chimiques reconnus dans l'état de Californie comme cancérigènes, responsables de malformations congénitales, ou comme nocifs à l'égard des fonctions de la reproduction.

**ADVERTENCIA:**

El escape del motor de esta herramienta contiene productos químicos que según la información del Estado de California producen cáncer, defectos congénitos u otros riesgos reproductivos.

*PROTOTYPE*

# Figures

**1**

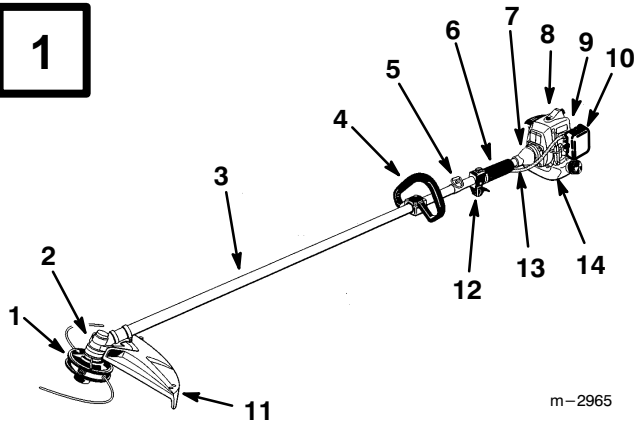

m-2965

**English**

- |   |  |
|---|--|
| 1. Trimmer Head                         | 9. Model and Serial Number Decal (on rear of engine stand) |
| 2. Gearcase                             | 10. Air Filter   |
| 3. Shaft Assembly                       | 11. Trimmer Head Shield                                    |
| 4. Loop Handle                          | 12. Throttle Trigger and Stop Switch                       |
| 5. Attachment Ring for Shoulder Harness | 13. Throttle Cable and Stop Switch Wire                    |
| 6. Shaft Grip                           | 14. Fuel Tank  |
| 7. Clutch Drum Housing                  |  |
| 8. Engine                               |  |

**2**

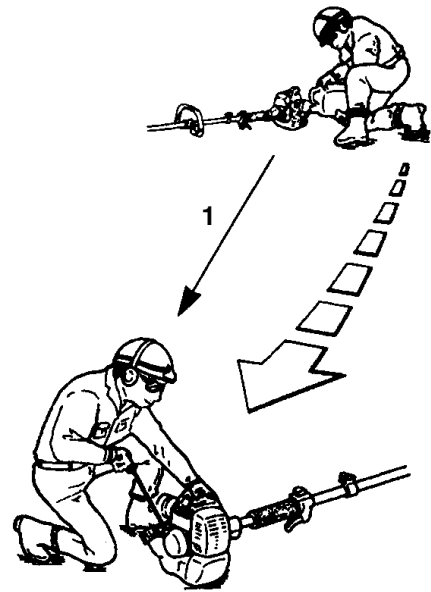

m-2966

**English**

1. 10 feet (3m) Minimum

PROTOTYPE

**3**

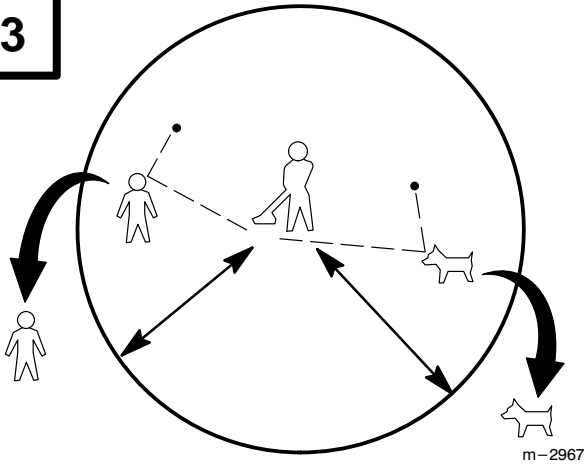

**English**

1. 50 ft. (15 m) Minimum

**5**

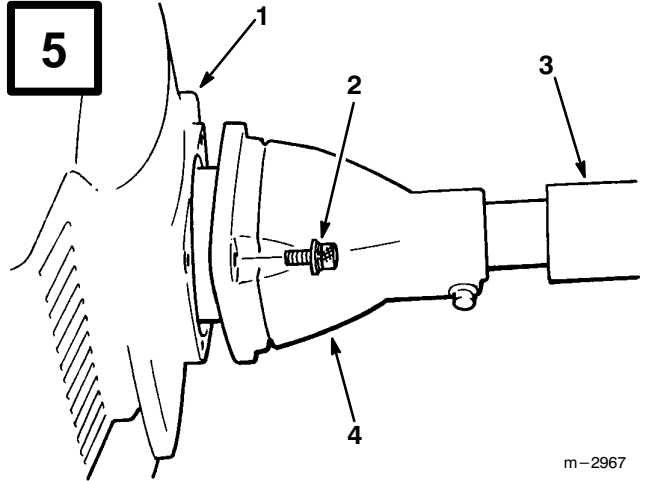

**English**

1. Engine
2. M5 x 20 or M6 x 20 Screw
3. Shaft
4. Clutch Drum Housing

**4**



ROTOTYPE

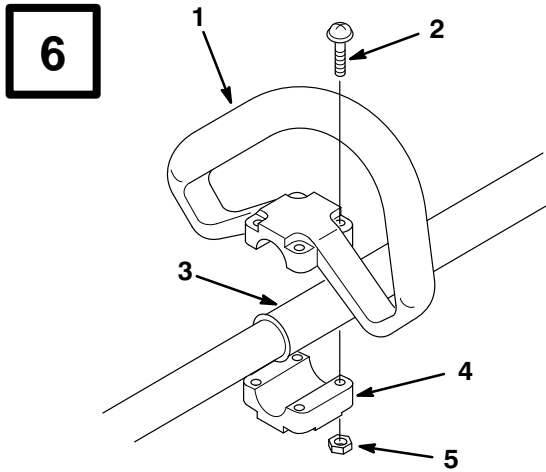

m-2970

**English**

- |                  |                 |
|------------------|-----------------|
| 1. Loop Handle   | 4. Bottom Clamp |
| 2. Screw (4)     | 5. Nut (4)      |
| 3. Rubber Sleeve |                 |

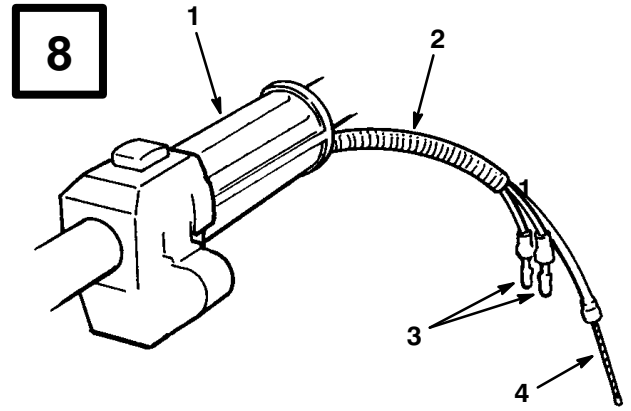

m-2972

**English**

- |                 |                      |
|-----------------|----------------------|
| 1. Shaft Grip   | 3. Stop Switch Wires |
| 2. Plastic Tube | 4. Throttle Cable    |

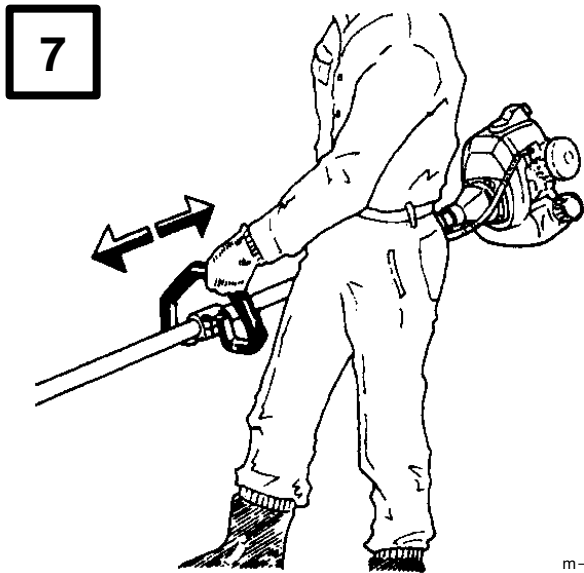

m-2971

PROTOTYPE

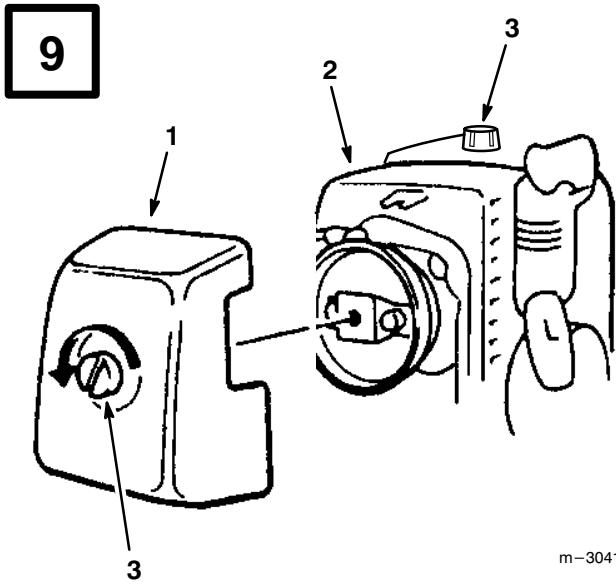

m-3041

**English**

- 1. Air Cleaner Cover
- 2. Cylinder Cover
- 3. Knob

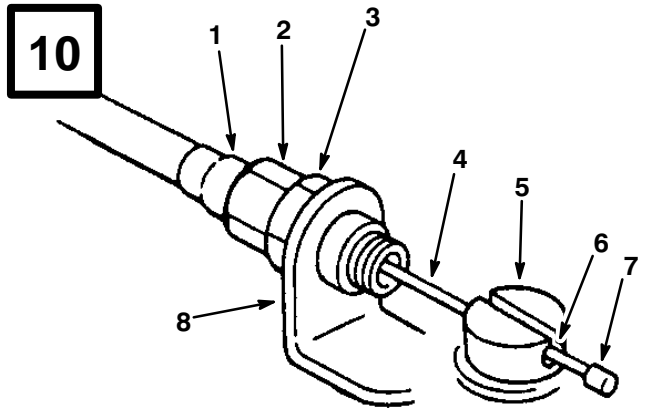

m-2973

**English**

- 1. Throttle Cable Housing
- 2. Cable Adjuster Sleeve
- 3. Locknut
- 4. Throttle Cable
- 5. Slotted Fitting
- 6. Recessed Hole
- 7. Cable Lug
- 8. Carburetor Bracket

PROTOTYPE

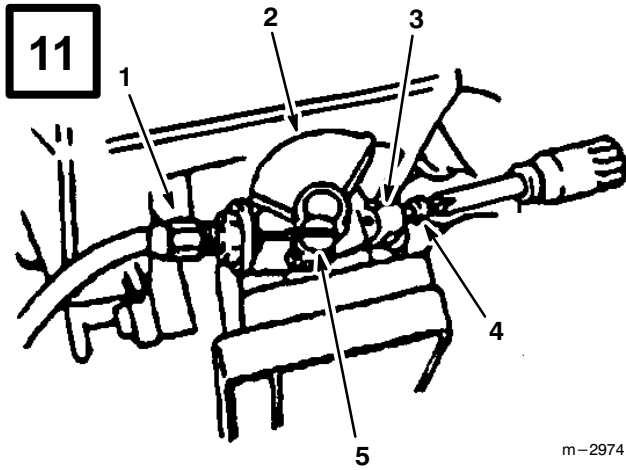

m-2974

**English**

- |  |                              |
|--|------------------------------|
| 1. Cable Adjuster Sleeve                           | 4. Idle Speed Adjuster Screw |
| 2. Carburetor Throttle Cam                         | 5. Slotted Fitting           |
| 3. Throttle Stop/Idle Speed Adjuster Screw Bracket |                              |

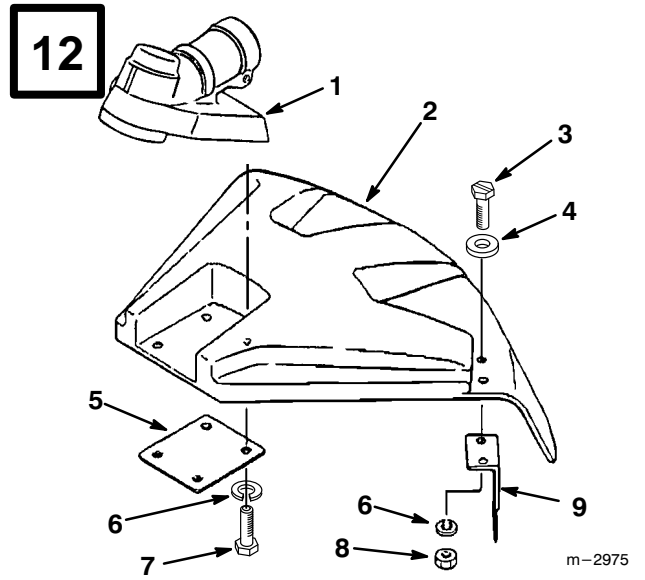

m-2975

**English**

- |                        |                        |
|------------------------|------------------------|
| 1. Gearcase            | 6. Lock Washer         |
| 2. Trimmer Head Shield | 7. M5 x 12 Screw (4)   |
| 3. M5 x 25 Screw (2)   | 8. Hex Nut             |
| 4. Flat Washer         | 9. String Cutoff Blade |
| 5. Plate               |                        |

PROTOTYPE

13

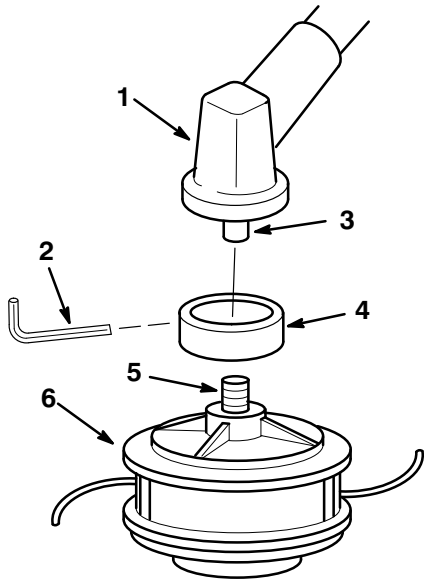

m-2976

**English**

- 1. Gearcase
- 2. 3mm Hex Wrench
- 3. Splined Shaft
- 4. Boss Adapter
- 5. Trimmer Head Adapter
- 6. Trimmer Head

14

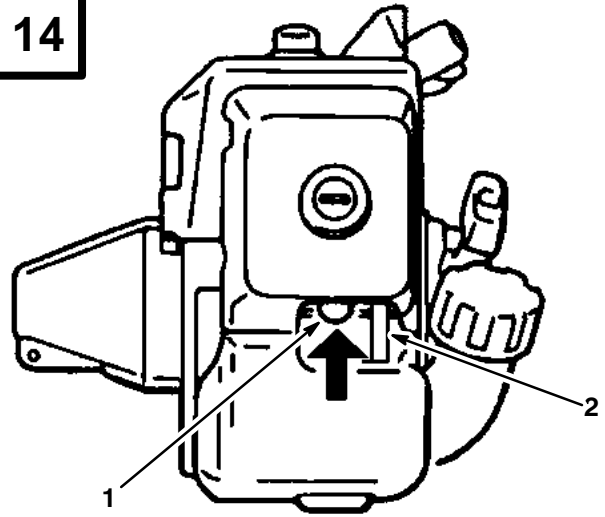

**Model 53002 & 53003**

m-2978

**English**

- 1. Primer Bulb
- 2. Fuel Return Line

PROTOTYPE

15

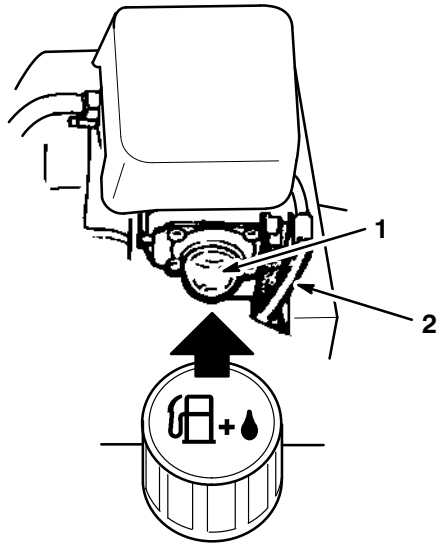

Model 53010 & 53011

m-3040

English

- 1. Primer Bulb
- 2. Fuel Return Line

17

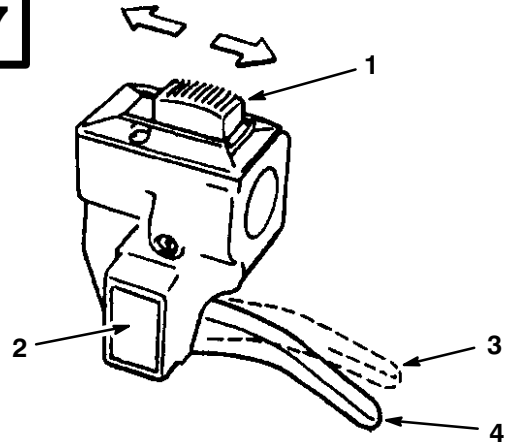

m-2939

English

- 1. Stop Switch
- 2. Fast-idle Lock
- 3. Throttle Trigger (in fast-idle start position)
- 4. Throttle Trigger (in idle position)

16

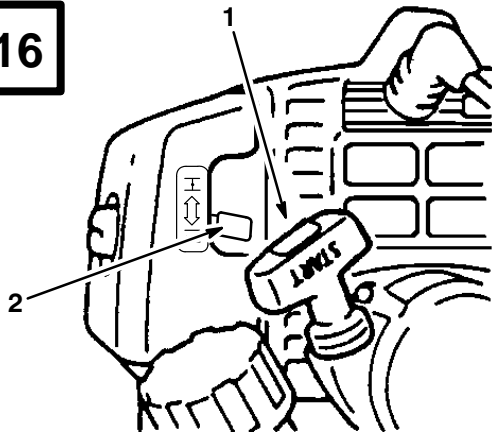

m-2938

ROTOTYPE

English

- 1. Starter Handle
- 2. Choke Lever (typical)

18

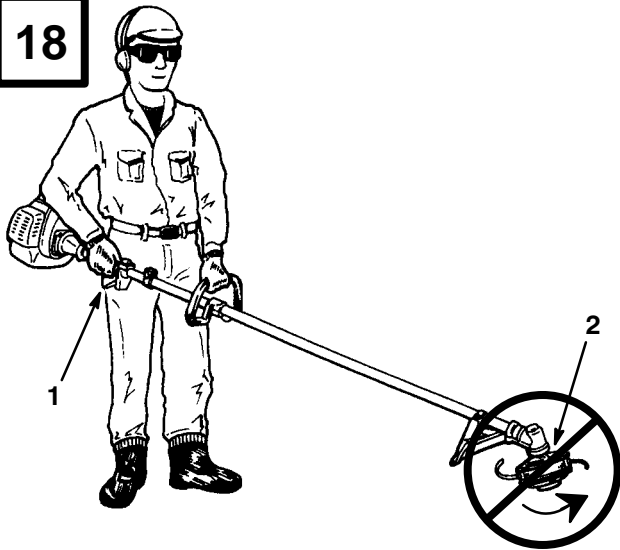

m-2968

English

- 1. Throttle Trigger in Idle Position
- 2. No Trimmer Head Rotation

20

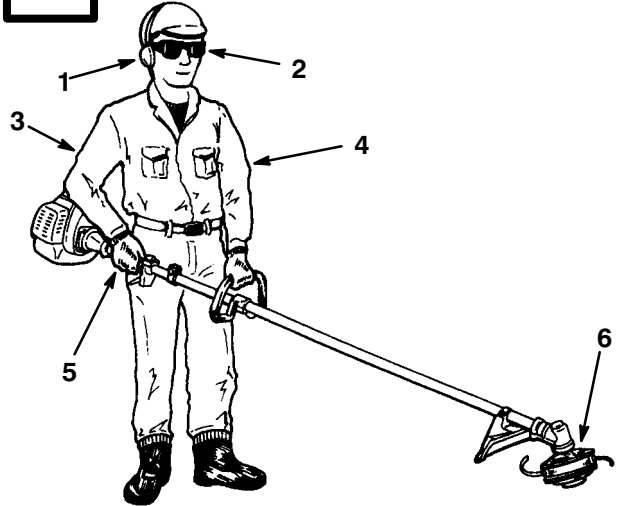

m-2968

English

- 1. Hearing Protection
- 2. Eye Protection
- 3. Right Arm Slightly Bent
- 4. Left Arm Fully Extended, Hand Holding Loop Handle
- 5. Hand Holding Throttle Grip, Fingers on Throttle Trigger
- 6. Trimmer Head Near and Parallel to Ground

19

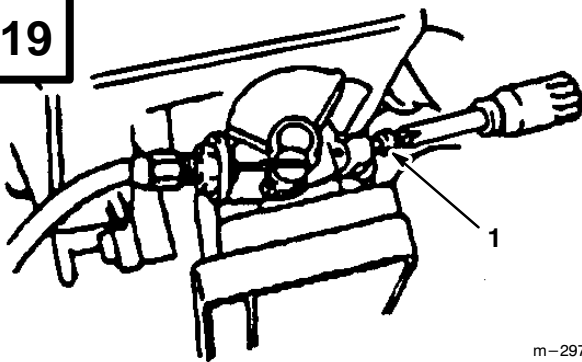

m-2974

English

- 1. Idle Speed Adjustment Screw

PROTOTYPE

21

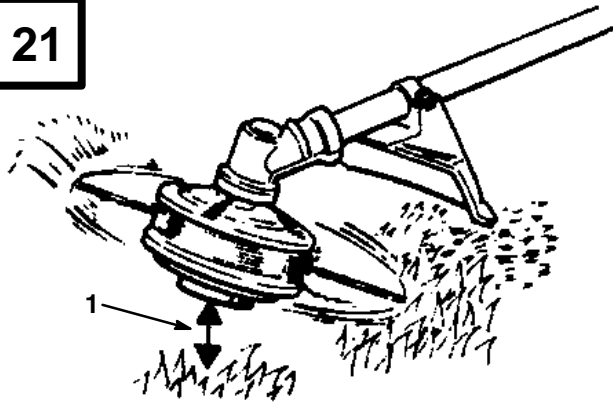

**CORRECT**

m-2979

English

1. Three inches (7.6 cm) Above Ground

23

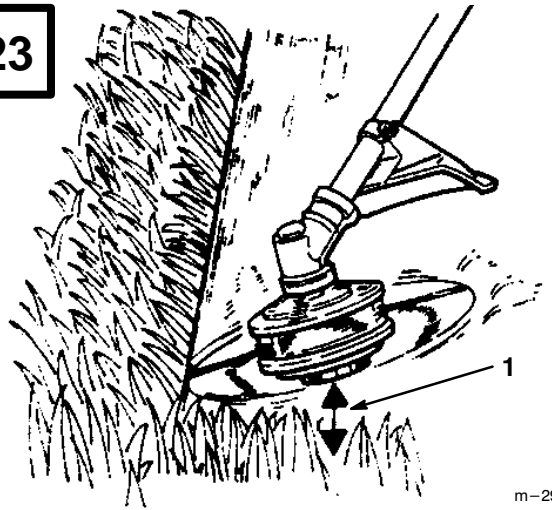

m-2981

English

1. Three inches (7.6 cm) Above Ground

22

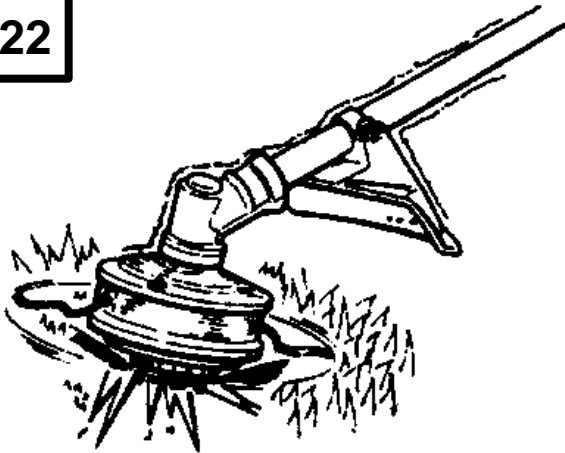

**INCORRECT**

m-2980

24

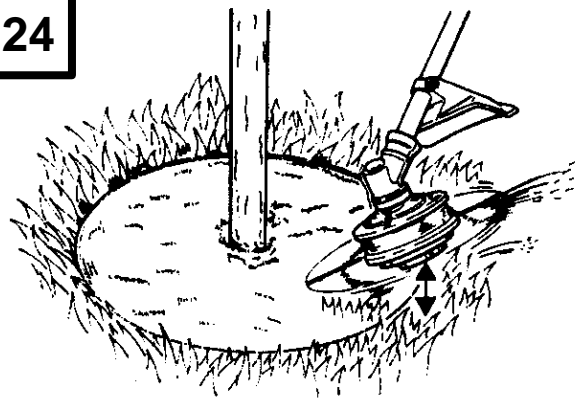

m-2982

PROTOTYPE

25

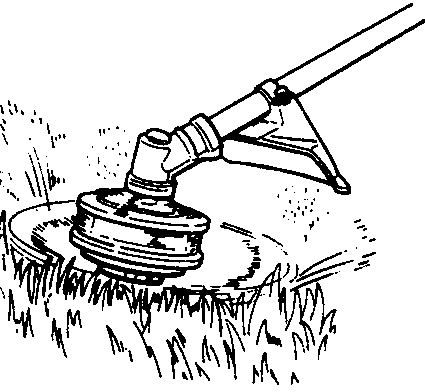

26

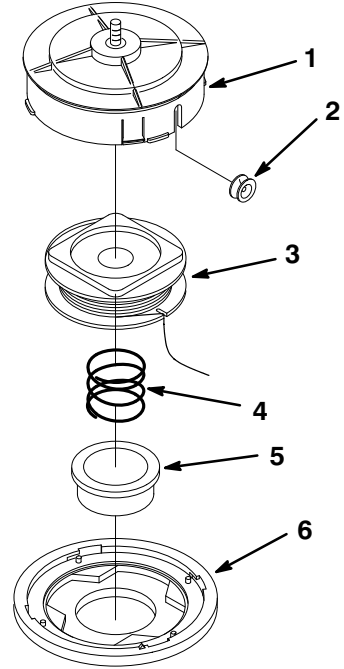

**4" and 5" Head Assembly**

**English**

- 1. Housing
- 2. Eyelet (2)
- 3. Spool (with Line)
- 4. Spring
- 5. Bump Knob
- 6. Spool Cover

PROTOTYPE

**27**

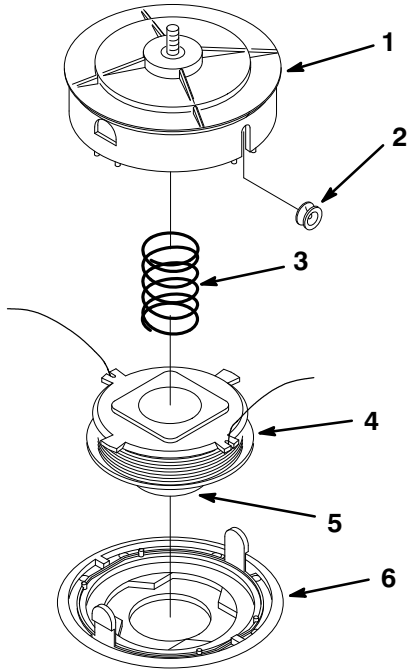

**6" Head Assembly**

**English**

- 1. Housing
- 2. Eyelet (2)
- 3. Spring
- 4. Spool (with Line)
- 5. Bump Knob
- 6. Spool Cover

**28**

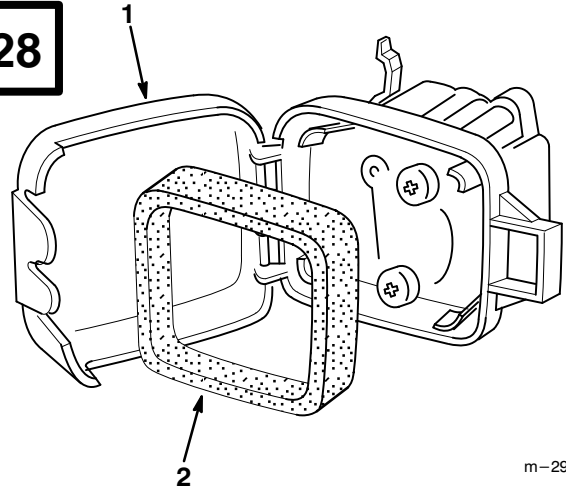

m-2930

**English**

- 1. Air Filter Cover
- 2. Foam Filter

**29**

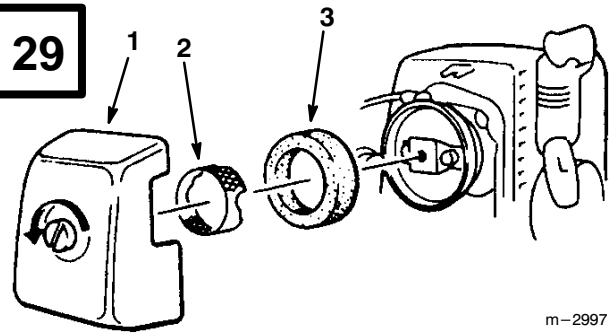

m-2997

**English**

- 1. Air Filter Cover
- 2. Filter Screen
- 3. Foam Ring

PROTOTYPE

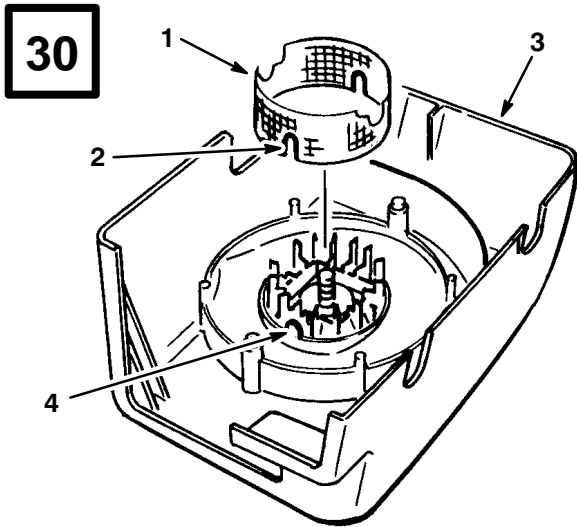

m-3010

**English**

- 1. Filter Screen
- 2. Cutout (typical)
- 3. Air Filter Cover
- 4. Plastic Post (typical)

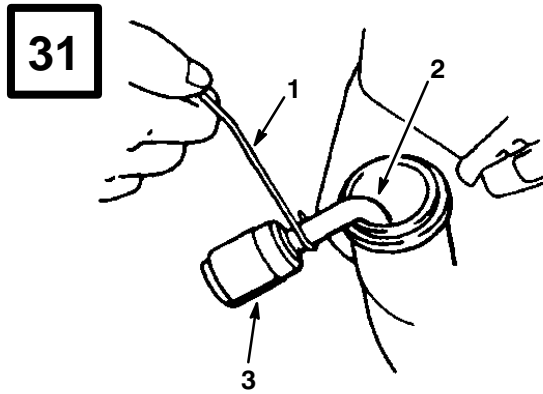

m-2931

**English**

- 1. Wire
- 2. Fuel Pick-up Hose
- 3. Fuel Filter

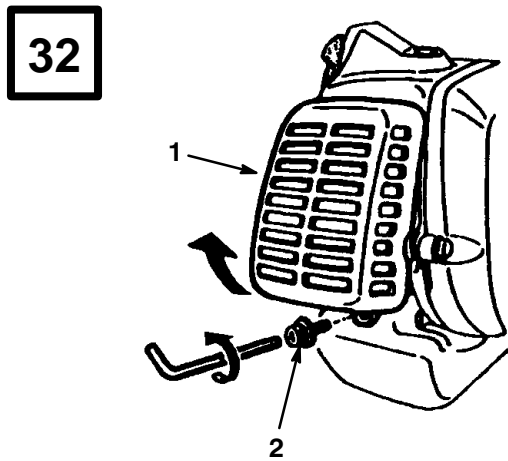

m-2927

**English**

- 1. Muffler Cover
- 2. Socket Head Screw

PROTOTYPE

**33**

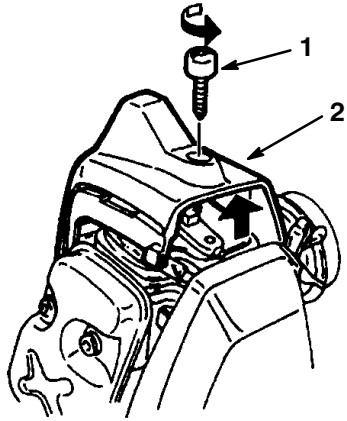

m-2934

**English**

- 1. Screw
- 2. Cylinder Cover

**35**

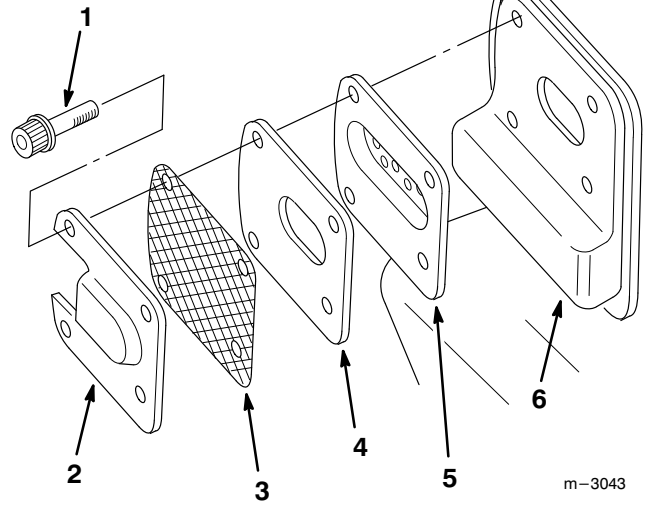

m-3043

**English**

- 1. Socket Head Screw (4)
- 2. Tail
- 3. Screen
- 4. Gasket
- 5. Plate
- 6. Muffler

**34**

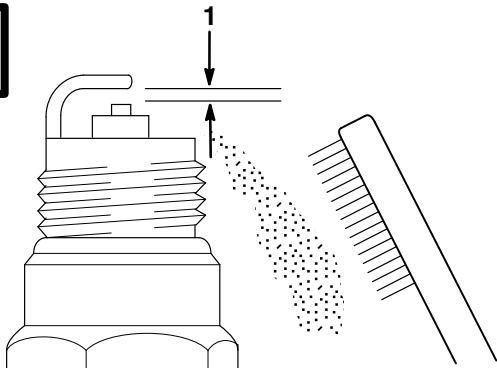

m-2932

**English**

- 1. .024"-.028" (0.6-0.7 mm)

PROTOTYPE

**36**

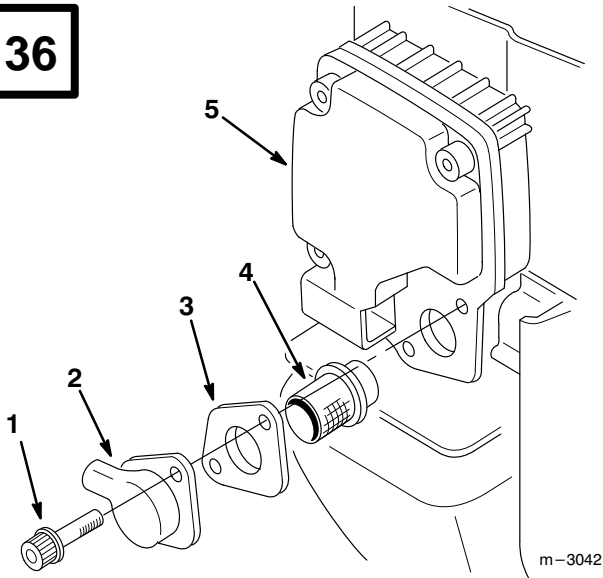

m-3042

**English**

- 1. Socket Head Screw (2)
- 2. Tail
- 3. Gasket
- 4. Spark Arrester
- 5. Muffler

**38**

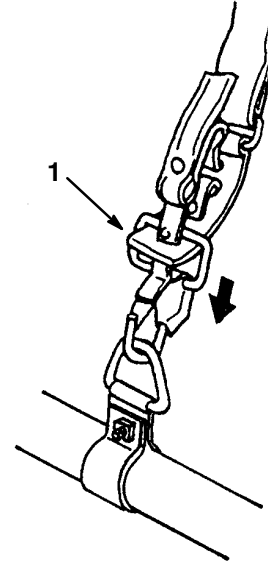

m-2991

**English**

- 1. Strap Harness

**37**

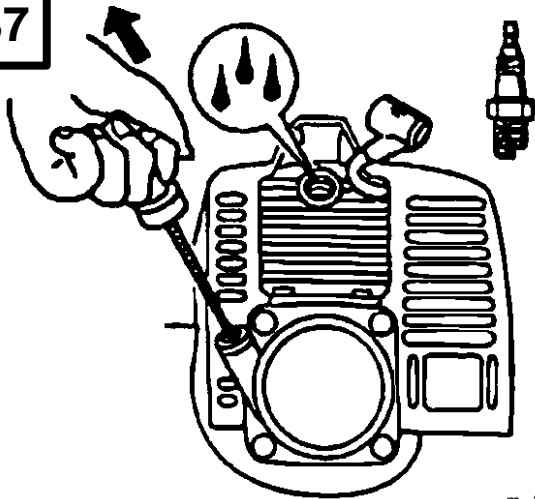

m-3002

ROTOTYPE

# Contents

	<b>Page</b>
Introduction .....	1
Safety .....	2
Operator Safety .....	2
String Trimmer Safety .....	2
Fuel Safety .....	3
Power String Trimmer Operating Safety ..	3
Safety and Instruction Decals .....	4
Assembly .....	4
Assembling Engine and Drive Shaft Assembly .....	4
Loop Handle Installation .....	4
Connecting Stop Switch Wires .....	5
Connecting Throttle Cable .....	5
Installing Trimmer Head Shield .....	5
Installing Trimmer Head .....	6
Before Operation .....	6
Oil and Fuel .....	6
Mixing Gasoline And Oil .....	8
Starting And Stopping .....	9
Idle Speed Adjustment .....	9
Operation .....	10
Operating Position .....	10
Cutting with Nylon Trimmer Line .....	11
Rewinding the Trimmer Spool .....	11
Maintenance .....	12
Air Filter .....	12
Fuel Filter .....	12
Spark Plug .....	12
Cylinder Cooling Fins .....	13
Spark Arrester .....	14
Gearcase Maintenance .....	14
General Cleaning and Tightening .....	15
Storage .....	15
Accessories .....	15
Troubleshooting .....	16
Specifications .....	17
California Emission Control	
Warranty Statement .....	18

Warranty .....	20
----------------	----

## Introduction

Thank you for purchasing a Toro product.

All of us at Toro want you to be completely satisfied with your new product, so feel free to contact your local Authorized Service Dealer for help with service, genuine Toro parts, or other information you may require.

Whenever you contact your Authorized Service Dealer or the factory, always know the model and serial numbers of your product. These numbers will help the Service Dealer or Service Representative provide exact information about your specific product. You will find the model and serial number decal located in a unique place on the product (Fig. 1).

For your convenience, write the product model and serial numbers in the space below.

**Model No.** \_\_\_\_\_

**Serial No.** \_\_\_\_\_

Read this manual carefully to learn how to operate and maintain your product correctly. Reading this manual will help you and others avoid personal injury and damage to the product. Although Toro designs, produces and markets safe, state-of-the-art products, you are responsible for using the product properly and safely. You are also responsible for training persons who you allow to use the product about safe operation.

The Toro warning system in this manual identifies potential hazards and has special safety messages that help you and others avoid personal injury, even death.

DANGER, WARNING and CAUTION are signal words used to identify the level of hazard. However, regardless of the hazard, be extremely careful.

**DANGER** signals an extreme hazard that will cause serious injury or death if the recommended precautions are not followed.

**WARNING** signals a hazard that may cause serious injury or death if the recommended precautions are not followed.

**CAUTION** signals a hazard that may cause minor or moderate injury if the recommended precautions are not followed. Two other words are also used to highlight information. “Important” calls attention to special mechanical information and “Note” emphasizes general information worthy of special attention.

# Safety

## Operator Safety

1. Read and understand this Operator’s Manual before using this product. Be thoroughly familiar with the proper use of this product.
2. Always wear eye protection that complies with ANSI (American National Standards Institute) Z87-1.



3. Always wear hearing protection.



4. Always wear heavy, long pants, boots and gloves. Do not wear loose clothing, jewelry, short pants, sandals, or go barefoot. Secure hair so it is above shoulder length.
5. Never operate this String Trimmer when you are tired, ill, or under the influence of alcohol, drugs or medication.
6. Never start or run the engine inside a closed room or building. Breathing exhaust fumes can cause death.



7. Keep handles clean of oil, fuel and dirt.

## String Trimmer Safety

1. Make sure the Trimmer is assembled correctly and that the trimmer head is correctly installed and securely fastened as instructed in the Assembly section.
2. Inspect the String Trimmer before each use. Replace damaged parts. Check for fuel leaks. Make sure all fasteners are in place and tightened securely. Follow the maintenance instructions beginning on page 12.
3. Make sure the trimmer head does not rotate at engine idle speed. Refer to Idle Speed Adjustment, page 9.
4. Inspect the String Trimmer cutting head and replace any parts that are cracked, chipped or damaged before using the Trimmer.
5. Install the required shield before using the Trimmer.
6. Use only flexible, non-metallic, monofilament cutting line of the correct diameter. Never use wire, rope, string, etc.
7. Never use a cutting head or replacement parts that are not approved by Toro.

PROTOTYPE

8. Maintain the String Trimmer according to the recommended maintenance intervals and procedures in the Maintenance section on page 12.
9. Shut off the engine and wait until the trimmer head has completely stopped moving before checking, performing maintenance on or working on the String Trimmer.
10. If running problems or excessive vibration occur, stop immediately and inspect the unit for the cause. If the cause cannot be determined or is beyond your ability to correct, return the String Trimmer to your servicing dealer for repair.
10. Store fuel and String Trimmer away from open flame, sparks and excessive heat. Make sure fuel vapors cannot reach sparks or open flames from water heaters, furnaces, electric motors, etc.

## Fuel Safety

1. Gasoline is highly flammable and must be handled and stored carefully. Use a container approved for fuel for storing gasoline and/or fuel/oil mixture.
2. Mix and pour fuel outdoors and where there are no sparks or flames.
3. Do not smoke near fuel or String Trimmer, or while using the String Trimmer.
4. Do not overfill the fuel tank. Stop filling 1/4–1/2 inch (6mm–13mm) from the top of the tank.
5. Wipe up any spilled fuel before starting the engine.
6. Move the Trimmer at least 10 feet (3 m) away from the fueling location before starting the engine (Fig. 2).
7. Do not remove the Trimmer fuel tank cap while the engine is running, or right after stopping the engine.
8. Allow the engine to cool before refueling.
9. Drain the tank and run the engine dry before storing the unit.
1. THIS STRING TRIMMER CAN CAUSE SERIOUS INJURIES. Read the instructions carefully. Be familiar with all controls and the proper use of the String Trimmer.
2. Inspect your work area before you begin. Remove objects such as broken glass, nails, wire and rocks which can become dangerous projectiles if thrown by the Trimmer. Remove string, rope or similar materials which can become entangled in the trimmer head.
3. This Trimmer will throw objects and cut. Keep children, bystanders and animals outside a 50 ft. (15 m) radius from the operator and Trimmer (Fig. 3). Beyond the 50 ft. (15 m) there still may be a risk of injury to bystanders from thrown objects. It is recommended that bystanders wear eye protection. A thrown object can ricochet.
4. If you are approached while operating the Trimmer, stop the engine and trimmer head rotation.
5. Never allow children to operate the Trimmer.
6. Use the Trimmer only in daylight or good artificial light.
7. Never operate the Trimmer without proper guards or other protective safety devices in place.
8. Always keep the Trimmer on the right side of your body (Fig. 4).
9. Do not raise the trimmer head above waist level.
10. Keep all parts of your body away from the rotating trimmer head and hot surfaces such as the muffler.
11. Keep firm footing and balance. Do not overreach.

## Power String Trimmer Operating Safety

- Use the right tool for the job. Do not use the Trimmer for any job that is not recommended by Toro.

## Safety and Instruction Decals



Safety decals and instructions are easily visible to the operator and are located near any area of potential danger. Replace any decal that is damaged or lost.



**ON SHAFT  
(Part No. M221501)**

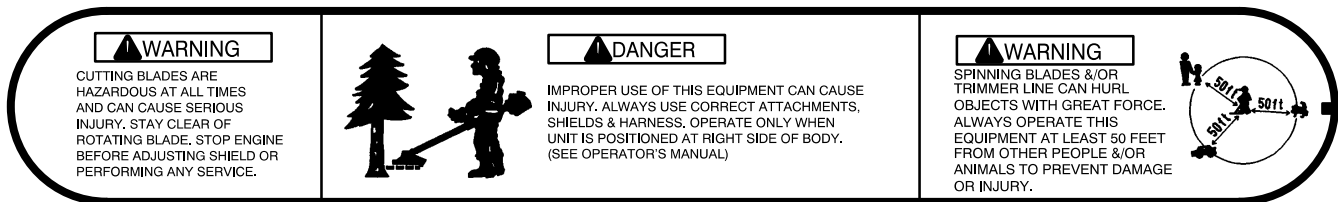

**ON SHAFT  
(Part No. M221502)**

## Assembly

### Assembling Engine and Drive Shaft Assembly

The drive shaft, clutch drum housing and gearcase are assembled. Attach the clutch drum housing to the engine using the four M5 x 20 or M6 x 20 screws supplied with the unit (Fig. 5).

## PROTOTYPE

### Loop Handle Installation

The loop handle kit contains a package of four screws and nuts, a rubber sleeve and the bottom clamp for the loop handle (Fig. 6).

- Slip the rubber sleeve around the shaft approximately 9 inches (22.8 cm) from the end of the stop switch/throttle trigger assembly for an initial handle position (Fig. 6).
- Rotate the rubber sleeve so the split is to one side (Fig. 6).

3. Place the loop handle and the bottom clamp over the rubber sleeve (Fig. 6).
4. Install the four screws and nuts. Leave the screws finger-tight (Fig. 6).
5. Reposition the loop handle up or down the drive shaft to the most comfortable position, but no closer than 9 inches (22.8 cm) from the end of the stop switch (Figs. 6 and 7).
6. Tighten the screws and nuts (Fig. 6).
2. Insert the throttle cable through the cable adjuster sleeve on the carburetor bracket. Make sure the end of the cable housing is seated positively in the sleeve (Figs. 10 and 11).
3. Position the slotted fitting on the carburetor so the recessed hole for the cable lug is away from the cable adjuster sleeve (Fig. 10).
4. Rotate the carburetor throttle cam clockwise and slip the throttle cable through the slot in the slotted fitting, making sure the cable lug drops into the recessed hole (Figs. 10 and 11).

## Connecting Stop Switch Wires

Install the plastic tube (packed with the drive shaft assembly) around the throttle cable and stop switch wires (Fig. 8).

### Model 53010 & 53011

Plug the stop switch wires into the matching wire connectors from the engine. Note that wire polarity is not important.

### Model 53002 & 53003

1. Loosen the knob and remove the air cleaner cover to access the stop switch wires (Fig. 9).
2. Plug the stop switch wires into the matching connectors from the engine.
3. Reinstall the air cleaner cover and tighten the knob (Fig. 9).

## Connecting Throttle Cable

1. Loosen the knob and remove the air cleaner cover (Models 53002 and 53003 only) (Fig. 9).

5. Operate the throttle trigger a few times to make sure that it works correctly (Fig. 17).
6. Adjust the cable adjuster sleeve so the stop on the carburetor throttle cam just contacts the throttle stop when the throttle trigger is fully depressed (Figs. 10 and 11).
7. When the throttle cable is adjusted correctly, tighten the locknut (Fig. 10).

## Installing Trimmer Head Shield

**⚠ CAUTION**

**POTENTIAL HAZARD**

- The cutoff blade is sharp.

**WHAT CAN HAPPEN**

- Contact with cutoff blade could cause serious cuts or personal injury.

**HOW TO AVOID THE HAZARD**

- Keep hands, feet and clothing away from cutoff blade.

1. Fasten the string cutoff blade to the trimmer head shield with two M5 x 25 screws, flat washers, lock washers and hex nuts as shown (Fig 12).

## **WARNING**

### **POTENTIAL HAZARD**

- Foreign objects can be thrown by Trimmer.

### **WHAT CAN HAPPEN**

- Contact with thrown objects can cause personal injury.

### **HOW TO AVOID THE HAZARD**

- Never operate the Trimmer without the trimmer head shield in place.

## **CAUTION**

### **POTENTIAL HAZARD**

- If the trimmer head is not adequately tightened, it can come loose from the Trimmer during use.

### **WHAT CAN HAPPEN**

- This may cause damage to property or personal injury.

### **HOW TO AVOID THE HAZARD**

- Make sure the trimmer head is securely fastened to the splined shaft in the gearcase.

2. Attach the trimmer head shield to the gearcase with the four M5 x 12 screws and lock washers as shown (Fig 12).

## **Installing Trimmer Head**

**IMPORTANT:** Make sure the trimmer head is for **LEFT-HAND ROTATION** (counterclockwise) as viewed from the operator's position, and that the trimmer head adapter is a male, M8 x 1.25 left-hand thread.

**IMPORTANT:** The boss adapter must be installed on the splined shaft between the gearcase and the trimmer head as shown in Fig. 13.

1. Install the boss adapter onto the splined shaft out of the gearcase (Fig. 13).
2. Align the hole in the boss adapter with the hole in the gearcase (Fig. 13).
3. Insert the 3mm hex wrench into the holes in the boss adapter and gearcase to lock the splined shaft (Fig. 13).
4. Thread the trimmer head adapter into the splined shaft, then tighten the trimmer head firmly by hand (Fig. 13).

## **Before Operation**

### **Oil and Fuel**

## **DANGER**

### **POTENTIAL HAZARD**

- In certain conditions gasoline is extremely flammable and highly explosive.

### **WHAT CAN HAPPEN**

- A fire or explosion from gasoline can burn you, others, and cause property damage.

### **HOW TO AVOID THE HAZARD**

- Use a funnel and fill the fuel tank outdoors, in an open area, when the engine is cold. Wipe up any gasoline that spills.
- **Do not fill the fuel tank completely full. Add gasoline to the fuel tank until the level is 1/4" to 1/2" (6 mm to 13 mm) below the bottom of the filler neck. This empty space in the tank allows gasoline to expand.**
- Never smoke when handling gasoline, and stay away from an open flame or where gasoline fumes may be ignited by a spark.
- Store gasoline in an approved container and keep it out of the reach of children.
- Never buy more than a 30-day supply of gasoline.

1. Do not smoke near fuel.

2. Mix and pour fuel outdoors and where there are no sparks or flames.
3. Always shut off the engine before refueling. Never remove the String Trimmer fuel tank cap while the engine is running or right after just stopping the engine.

## **WARNING**

### **POTENTIAL HAZARD**

- Gasoline contains gasses that can build up pressure inside a gas tank.

### **WHAT CAN HAPPEN**

- Fuel can be sprayed on you when removing gas cap.

### **HOW TO AVOID THE HAZARD**

- Remove fuel cap slowly to avoid injury from fuel spray.

4. Always open the fuel tank cap slowly to release any possible overpressure inside the tank.
5. Do not overfill the fuel tank. Stop filling 1/4–1/2 inch (6mm–13mm) from the top of the tank.
6. Tighten the tank fuel cap carefully but firmly after refilling.
7. Wipe up any spilled fuel before starting the engine.
8. Move the String Trimmer at least 10 feet (3 m) away from the fueling location and fuel storage container before starting the engine (Fig. 2).

## **Recommended Oil Type**

Only use a two-cycle engine oil formulated for use in high-performance, air-cooled two-cycle engines. Toro brand 2-cycle oil is formulated for use in high-performance, air-cooled two-cycle engines.

**IMPORTANT: Do not use National Marine Manufacturer's Association (NMMA) or BIA certified oils. This type of 2-cycle engine oil does not have the proper additives for air-cooled, 2-cycle engines and can cause engine damage.**

**Do not use automotive motor oil. This type of oil does not have the proper additives for air-cooled, 2-cycle engines and can cause engine damage.**

## **Recommended Fuel Type**

Use clean, fresh lead-free gasoline, including *oxygenated* or *reformulated* gasoline, with an octane rating of 85 or higher. To ensure freshness, purchase only the quantity of gasoline that can be used in 30 days. Use of lead-free gasoline results in fewer combustion chamber deposits and longer spark plug life. Use of premium grade fuel is not necessary or recommended.

## **Use Of Fuel Additives**

**IMPORTANT: NEVER USE METHANOL, GASOLINE CONTAINING METHANOL, GASOHOL CONTAINING MORE THAN 10% ETHANOL, PREMIUM GASOLINE, OR WHITE GAS BECAUSE ENGINE FUEL SYSTEM DAMAGE COULD RESULT.**

**DO NOT USE FUEL ADDITIVES OTHER THAN THOSE MANUFACTURED FOR FUEL STABILIZATION DURING STORAGE SUCH AS TORO'S STABILIZER/CONDITIONER OR A SIMILAR PRODUCT. TORO'S STABILIZER/CONDITIONER IS A PETROLEUM DISTILLATE BASED CONDITIONER/STABILIZER.**

**TORO DOES NOT RECOMMEND STABILIZERS WITH AN ALCOHOL BASE SUCH AS ETHANOL, METHANOL OR ISOPROPYL. ADDITIVES SHOULD NOT BE USED TO TRY TO ENHANCE THE POWER OR PERFORMANCE OF MACHINE.**

## Mixing Gasoline And Oil

**IMPORTANT:** The engine used on this String Trimmer is of a 2-cycle design. The internal moving parts of the engine, i.e., crankshaft bearings, piston pin bearings and piston to cylinder wall contact surfaces, require oil mixed with the gasoline for lubrication.

Failure to add oil to the gasoline or failure to mix oil with the gasoline at the appropriate ratio will cause major engine damage which will void your warranty.

For your fuel premix, only use a quality oil designed for 2-cycle air cooled engines. Toro 50:1 2-Cycle Oil is formulated to meet the requirements of high-performance, air-cooled two-cycle engines.

### Fuel Mixture

The fuel:oil ratio is 50 parts gasoline to 1 part oil or 50:1.

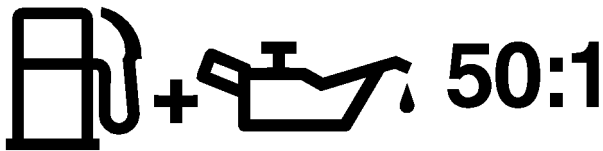

**Note:** Never use a mixing ratio less than 50:1 regardless of the oil package mixing instructions. Ratios less than 50:1, (for example, 60:1, 80:1, 100:1), reduce the amount of lubrication to the internal moving parts of the engine and can cause damage.

## Fuel Mixture Chart

Gasoline	50:1 2-cycle oil
1 gallon	2.6 oz.
2 gallons	5.2 oz.
5 gallons	12.8 oz.

### Mixing Instructions

**IMPORTANT:** Never mix gasoline and oil directly in the String Trimmer fuel tank.

1. Always mix fuel and oil in a clean container approved for gasoline.
2. Mark the container to identify it as fuel mix for the String Trimmer.
3. Use regular unleaded gasoline and fill the container with half the required amount of gasoline.
4. Pour the correct amount of oil into the container then add the remaining amount of gasoline.
5. Close the container tightly and shake it momentarily to evenly mix the oil and the gasoline before filling the fuel tank on the String Trimmer.
6. When refilling the String Trimmer fuel tank, clean around the fuel tank cap to prevent dirt and debris from entering the tank during cap removal.
7. Always shake the premix fuel container momentarily before filling the fuel tank
8. Always use a spout or funnel when fueling to reduce fuel spillage.
9. Fill the tank only to within 1/4–1/2 inch (6mm–13mm) from the top of the tank. Avoid filling to the top of the tank filler neck.

# Starting And Stopping

## Before Starting The Engine

1. Fill the fuel tank as instructed in the Before Operation section of this manual.
2. Rest the String Trimmer on the ground.
3. Make sure the trimmer head is clear of any broken glass, nails, wire, rocks or other debris.
4. Keep all bystanders, children and animals away from the working area.

## Cold Starting Procedure

The carburetors on Toro engines contain a choke system. To start a “cold” engine properly, perform the following procedure:

1. Pump the primer bulb at the bottom of the carburetor until fuel can be seen flowing through the fuel return line to the fuel tank (Figs. 14 and 15). (Flowing fuel should be almost clear, not foamy or full of bubbles.)
2. Move the choke lever to the closed ( $\overline{I}$ ) position and move the stop switch to the “ON” position (Figs. 16 and 17).
3. Lock the throttle trigger in the fast-idle start position, then pull the starter handle (Figs. 16 and 17).
4. After the engine starts, move the choke lever to the open ( $\overline{\pm}$ ) position, then squeeze and release the throttle trigger to allow it to return to the idle position (Figs. 16 and 17).

If the engine stops running before you move the choke lever to the open ( $\overline{\pm}$ ) position:

- A. Go ahead and open the choke (Fig. 16).

- B. Make sure the throttle trigger is set to the fast-idle start position (Fig. 17).
- C. Pull the starter handle until the engine starts (Fig. 16).

## Hot Restart

To start an engine that is already warmed up (hot restart), or if the ambient temperature exceeds 68°F (20°C):

1. Pump the primer bulb at the bottom of the carburetor until fuel can be seen flowing through the fuel return line to the fuel tank (Figs. 14 and 15).
2. Move the choke lever to the open ( $\overline{\pm}$ ) position and move the stop switch to the “ON” position (Figs. 16 and 17).
3. Leave the throttle trigger in the idle position and pull the starter handle (Figs. 16 and 17).
4. If the engine fails to start after three to four pulls, follow the instructions in the Cold Starting Procedure section above.

If the engine fails to start after you follow the above procedures, contact an authorized Toro dealer.

## To Stop The Engine:

1. Release the throttle trigger (Fig. 17).
2. Slide the stop switch to the “STOP” position (Fig. 17).

## Idle Speed Adjustment

This String Trimmer is equipped with non-adjustable fuel mixture carburetor. The engine idle speed is the only adjustment for the operator.

## **WARNING**

### **POTENTIAL HAZARD**

- Engine must be running to make some carburetor adjustments.
- When engine is running, trimmer head is rotating and other parts are moving.

### **WHAT CAN HAPPEN**

- Contact with rotating trimmer head or other moving parts could cause serious personal injury or death.

### **HOW TO AVOID THE HAZARD**

- Keep hands, feet and clothing away from trimmer head and other moving parts.
- Keep all bystanders and pets away from unit while making carburetor adjustments.

The trimmer head may be rotating during idle speed adjustment. Wear the recommended personal protective equipment and observe all safety instructions. Keep hands and body away from the trimmer head.

When the throttle trigger is released, the engine should return to an idle speed between 2400 and 2800 RPM, or just below the clutch engagement speed. The trimmer head must not rotate and the engine should not stall (stop running) at engine idle speed (Fig. 18).

To adjust the engine idle speed, rotate the idle speed adjustment screw on the carburetor (Fig. 19).

- Turn the idle speed screw in (clockwise) to increase the engine idle speed.
- Turn the screw out (counterclockwise) to decrease the engine idle speed.

**If idle speed adjustment is necessary, and after adjustment the trimmer head rotates or the engine stalls, stop using the String Trimmer immediately!**

Contact your local authorized Toro Dealer for assistance and servicing.

## **Operation**

## **CAUTION**

- Read the Safety instructions on page 2 concerning proper use of the String Trimmer.

## **Operating Position**

Before using the Trimmer, check the following (Fig. 20):

1. The Trimmer should be on the operator's right side.
2. The operator's right hand should be holding the shaft grip, with his or her fingers on the throttle trigger. The right arm should be slightly bent.
3. The left hand should be holding the loop handle with the fingers and thumb fully enclosed around the grip. The left arm should be extended. Reposition the loop handle up or down the driveshaft if necessary for a comfortable position.
4. The Trimmer weight should be evenly distributed between the arms. The trimmer head should be near and parallel to the ground.
5. Accelerate and hold the engine at cutting speed before entering the material to be cut.
6. Always release the throttle trigger and allow the engine to return to idle speed when not cutting.
7. Stop the Trimmer engine when moving between work sites.

## **CAUTION**

- Always wear gloves and protective clothing when operating the String Trimmer.

- If the trimmer head becomes jammed, stop the engine immediately.

- Make certain all moving parts have stopped and disconnect the spark plug before inspecting the equipment for damage.
- Never use a String Trimmer that has chipped, cracked or broken trimmer head.

## Cutting with Nylon Trimmer Line

- The tip of the line does the cutting. The line should stay extended while cutting (Fig. 21).
- Do not force the line into the material. Forcing the line will cause it to slap against the material, increasing line usage and causing poor cutting results (Fig. 22).

## Trimming

Hold the bottom of the trimmer head about 3 in. (7.6 cm) above the ground and at an angle. Allow only the tip of the line to make contact (Figs. 21 and 23).

## Scaling

To remove unwanted vegetation, hold the trimmer head about 3 in. (7.6 cm) above the ground and at an angle. Allow the tip of the line to strike the ground cutting the vegetation off at the surface (Fig. 24).

## Mowing

Keep the line parallel to the ground and use a gentle side-to-side motion (Fig. 25).

## Rewinding the Trimmer Spool

### WARNING

#### POTENTIAL HAZARD

- Use of improper line could cause line to break and be thrown in operator's or bystander's direction.

#### WHAT CAN HAPPEN

- Use of improper line could result in serious personal injury.

#### HOW TO AVOID THE HAZARD

- Use only good quality, commercial grade, weld resistant trimmer line with a diameter of .095 inches (2.413 mm).
- Do not use any type of wire or other string-like substance. Do not use metal-reinforced line.

1. Unlock the spool cover by depressing the tab and turning the cover clockwise (Figs. 26 and 27).
2. Remove the cover and bump knob (Figs. 26 and 27).
3. Remove the spool. Make sure the metal eyelets and spring do not fall out (Figs. 26 and 27).
4. Clean the dirt from the inside of the spool parts if required.
5. Use approximately 20 to 25 feet (6 to 7.6 m) of new trimmer line and fold the line in half.
6. Insert one end of the new line through the hole in the spool shaft (Figs. 26 and 27).
7. Wind the line in even, tight layers onto the spool in the direction indicated on the spool.
8. Thread the two ends of the line through the eyelets (Figs. 26 and 27).
9. Replace the bump knob and spool cover. Align the pointed projections and turn the cover counterclockwise (Figs. 26 and 27).

# Maintenance

## Air Filter

### Maintenance Interval

- The air filter should be cleaned **daily**, or more often when working in extremely dusty conditions.
- Replace after every 100 hours of operation.

### Air Filter Cleaning

*Model 53010 & 53011*

1. Unsnap the air filter cover (Fig. 28).
2. Remove the foam filter (Fig. 28).
3. Clean the filter with warm, soapy water. Let the filter completely dry.
4. Apply a light coat of SAE 30 motor oil to the foam filter and squeeze out all excess oil.
5. Reassemble the filter and filter cover (Fig. 28).

*Model 53002 & 53003*

1. Loosen the knob and remove the air filter cover (Fig. 29).
2. Remove the foam ring and filter screen from the air filter cover (Fig. 29).
3. Clean the foam ring and filter screen with warm, soapy water. Let the screen and ring dry completely.
4. Apply a light coat of SAE 30 motor oil to the foam ring and squeeze out all excess oil.
5. Reassemble the filter screen and foam ring to the air filter cover (Fig. 29).

**IMPORTANT:** The air filter screen is designed to fit into the air filter cover **ONE WAY ONLY**. Make sure the cutouts in the screen fit onto the matching plastic posts in the air filter cover. The fit should be snug (Fig. 30).

6. Reinstall the air filter cover and tighten the knob (Fig. 29).

## Fuel Filter

### Maintenance Interval

The fuel filter should be replaced after every 100 hours of operation.

### Fuel Filter Replacement

The fuel filter is attached to the end of the fuel pick-up hose inside the fuel tank (Fig. 31).

To replace the fuel filter:

1. Make sure the fuel tank is empty.
2. Remove the fuel cap.
3. Using a wire hook, gently pull the fuel filter out through the fuel filler opening (Fig. 31).
4. Grasp the fuel hose next to the fuel filter fitting and remove the filter, but do not release the hose.
5. While still holding on to the fuel hose, attach the new fuel filter.
6. Drop the new fuel filter back into the fuel tank.
7. Make sure that the fuel filter is not stuck in a corner of the tank, and that the fuel hose is not doubled over (kinked) before refueling.

## Spark Plug

### Maintenance Interval

- The spark plug should be removed from the engine and checked after each 25 hours of operation.

- Replace the spark plug (NGK BPM6Y) after every 100 hours of operation.

## Spark Plug Maintenance

### *Model 53010 & 53011*

1. With the engine at ambient (room) temperature, remove the socket head screw holding the muffler cover, then remove the muffler cover (Fig. 32).
2. Loosen the cylinder cover screw and lift off the cylinder cover (Fig. 33).
3. Twist the high tension lead boot on the spark plug back and forth a couple of times to loosen the boot, then pull the boot off of the spark plug.
4. Remove the spark plug.
5. Clean the electrodes with a stiff brush (Fig. 34).
6. Adjust the electrode air gap to .024–.028 in. (0.6–0.7mm) (Fig. 34).
7. Replace the spark plug if it is oil-fouled, damaged, or if the electrodes are worn down.
8. Do not overtighten the spark plug when installing. The tightening torque is 95–148 in. lbs. (10.7–16.6 N•m).
9. Reinstall the cylinder and muffler covers (Figs. 32 and 33).

### *Model 53002 & 53003*

1. With the engine at ambient (room) temperature, loosen the knob and remove the air cleaner cover (Fig. 9).
2. Loosen the knob and lift off the cylinder cover (Fig. 9).
3. Twist the high tension lead boot on the spark plug back and forth a couple of times to loosen the boot, then pull the boot off of the spark plug.
4. Remove the spark plug.

5. Clean the electrodes with a stiff brush (Fig. 34).
6. Adjust the electrode air gap to .024–.028 in. (0.6–0.7mm) (Fig. 34).
7. Replace the spark plug if it is oil-fouled, damaged, or if the electrodes are worn down.
8. Do not overtighten the spark plug when installing. The tightening torque is 95–148 in. lbs. (10.7–16.6 N•m).
9. Reinstall the cylinder and air cleaner covers (Fig. 9).

## Cylinder Cooling Fins

### Maintenance Interval

The cylinder cooling fins should be cleaned after every 25 hours of operation, or once a week, whichever comes first.

Air must flow freely around and through the cylinder cooling fins to prevent engine overheating. Leaves, grass, dirt and debris buildup on the fins will increase the operating temperature of the engine, which can reduce engine performance and shorten engine life.

### Cooling Fin Cleaning

#### *Model 53010 & 53011*

1. With the engine cool (ambient or room temperature), remove the socket head screw holding the muffler cover, then remove the muffler cover (Fig. 32).
2. Loosen the cylinder cover screw and remove the cylinder cover (Fig. 33).
3. Clean all dirt and debris from the cooling fins and from around the cylinder base.
4. Reinstall the cylinder cover and the muffler cover (Figs 32 and 33).

#### *Model 53002 & 53003*

1. With the engine at ambient (room) temperature, loosen the knob and remove the air cleaner cover (Fig. 9).

2. Loosen the knob and lift off the cylinder cover (Fig. 9).
3. Clean all dirt and debris from the cooling fins and from around the cylinder base.
4. Reinstall the cylinder and air cleaner covers (Fig. 9).

## Spark Arrester

### **WARNING**

#### **POTENTIAL HAZARD**

- **Muffler surface becomes hot when Trimmer is in operation and remains hot for some time after the engine is shut off.**

#### **WHAT CAN HAPPEN**

- **Contact with hot muffler surfaces could cause a burn.**

#### **HOW TO AVOID THE HAZARD**

- **Make sure the muffler is cool before inspecting and cleaning the spark arrester.**

## Maintenance Interval

- The spark arrester should be inspected and cleaned after every 25 hours of use.
- Replace the screen if it cannot be thoroughly cleaned, or if it is damaged.

## Spark Arrester Maintenance

*Model 53010 & 53011*

1. With the engine at ambient (room) temperature, remove the socket head screw holding the muffler cover, then remove the muffler cover (Fig. 32).

2. Remove the four socket head screws holding the spark arrester assembly to the muffler (Fig. 35).
3. Remove and clean the tail, screen, gasket and plate with a safety solvent and a stiff brush. If any part cannot be thoroughly cleaned, it must be replaced.
4. Reinstall the plate, gasket, screen and tail onto the muffler, then reinstall and tighten the four socket head screws (Fig. 35).
5. Reinstall the muffler cover (Fig. 32).

*Model 53002 & 53003*

1. With the engine at ambient (room) temperature, loosen the knob and remove the air cleaner cover (Fig. 9).
2. Loosen the knob and lift off the cylinder cover (Fig. 9).
3. Remove the two socket head screws holding the spark arrester assembly to the muffler (Fig. 36).
4. Remove and clean the tail, gasket and spark arrester with a safety solvent and a stiff brush. If any part cannot be thoroughly cleaned, it must be replaced.
5. Reinstall the spark arrester, gasket and tail onto the muffler, then reinstall and tighten the two socket head screws (Fig. 36).
6. Reinstall the cylinder and air cleaner covers (Fig. 9).

## Gearcase Maintenance

The gearcase is a sealed unit which has been greased at the factory. No gearcase maintenance or lubrication is required or recommended.

PROTOTYPE

## General Cleaning and Tightening

### WARNING

#### POTENTIAL HAZARD

- When engine is running, cutting head is rotating and other parts are moving.

#### WHAT CAN HAPPEN

- Contact with rotating cutting head or other moving parts could cause serious personal injury or death.

#### HOW TO AVOID THE HAZARD

- Always turn off your Trimmer before you clean or perform any maintenance on it.

The Toro String Trimmer will provide maximum performance for many, many hours if it is maintained properly. Good maintenance includes regular checking of all fasteners for correct tightness, and cleaning the entire machine.

## Storage

For long-term storage of the String Trimmer:

1. Empty the fuel tank into a suitable fuel storage container.
2. Pump the primer bulb on the carburetor until all fuel is discharged through the clear fuel return hose.
3. Run the engine to remove any fuel that may remain in the carburetor.
4. Perform all regular maintenance procedures and any needed repairs.
5. Remove the spark plug and squirt a very small amount of oil into the cylinder (Fig. 37).

### CAUTION

#### POTENTIAL HAZARD

- Oil may squirt out of the spark plug opening when you pull the starter handle.

#### WHAT CAN HAPPEN

- Oil can cause eye injuries.

#### HOW TO AVOID THE HAZARD

- Protect your eyes and keep your face away from the spark plug opening.

6. Pull the starter handle once.
7. Slowly pull the starter handle to bring the piston to the top of the cylinder (TDC).
8. Reinstall the spark plug.
9. Store the String Trimmer in a dry place away from excessive heat, sparks or open flame.

## Accessories

The following accessories may be purchased at your local authorized TORO Service Dealer.

1. **Single Strap Harness, Model No. 46-2951** and **Deluxe Strap Harness, Model No. 46-2961**—safety release straps made out of durable nylon webbing (Fig. 38).

**! WARNING**

**POTENTIAL HAZARD**

- Without the Brushcutter blade shield installed on the String Trimmer, the Brushcutter blade can throw foreign objects.
- Without the correct blade shield, handles and strap installed on the String Trimmer, the Brushcutter can produce side thrust which can expose the operator and bystanders to blade contact.

**WHAT CAN HAPPEN**

- Contact with the Brushcutter blade or thrown objects can cause severe personal injury.

**HOW TO AVOID THE HAZARD**

- Never install only a Brushcutter blade onto a String Trimmer.
- To convert a String Trimmer to a Brushcutter, you must purchase and install the entire Brushcutter Accessory Kit.

2. **Brushcutter Accessory Kit, Model No. 53050**—allows you to convert the String Trimmer to a Brushcutter; available for Industrial Models (53002 and 53003) only.

# Troubleshooting

Problem	Cause	Action
Engine Will Not Start	STOP switch set to off position Empty fuel tank Primer bulb wasn't pushed enough Engine flooded	Move switch to on position Fill fuel tank Press primer bulb until fuel flows through fuel return line Use warm engine starting procedure
Engine Will Not Idle	Idle speed set incorrectly	Set idle speed
Engine Lacks Power or Stalls When Cutting	Throttle wire has come loose Dirty air filter	Tighten throttle wire Clean or replace air filter

**If further assistance is required, contact your local authorized Toro service dealer.**

# Specifications

**Note:** All models are CARB approved.

## 53010/Commercial

Engine Displacement	23cc
Shaft	Straight (59"/150 cm) steel with 5 ball bearings, 5 bushings
Anti Vibration	Dual Isolation – grip and engine mount
Carburetor	Walbro – Choke Type
Ignition System	Solid State
Fuel Tank Capacity	0.63 qts. (0.6 liter)
Gas to Oil Ratio	50:1
Cutting Head	4" Semiautomatic
Weight	12.6 lbs. (5.7 kg)
Spark Plug	NGK BPM6Y
Spark Plug Gap	.024–.028 in (0.6–0.7mm)

## 53002/Industrial

Engine Displacement	26cc
Shaft	Straight (59"/150 cm) steel with 6 ball bearings, 5 bushings
Anti Vibration	Dual Isolation – grip and engine mount
Carburetor	Walbro – Choke Type
Ignition System	Solid State
Fuel Tank Capacity	0.85 qts. (0.8 liter)
Gas to Oil Ratio	50:1
Cutting Head	5" Semiautomatic
Weight	14.8 lbs. (6.7 kg)
Spark Plug	NGK BPM6Y
Spark Plug Gap	.024–.028 in (0.6–0.7mm)

## 53011/Commercial

Engine Displacement	26cc
Shaft	Straight (59"/150 cm) steel with 5 ball bearings, 5 bushings
Anti Vibration	Dual Isolation – grip and engine mount
Carburetor	Walbro – Choke Type
Ignition System	Solid State
Fuel Tank Capacity	0.74 qts. (0.7 liter)
Gas to Oil Ratio	50:1
Cutting Head	4" Semiautomatic
Weight	13.3 lbs. (6 kg)
Spark Plug	NGK BPM6Y
Spark Plug Gap	.024–.028 in (0.6–0.7mm)

## 53003/Industrial

Engine Displacement	32cc
Shaft	Straight (59"/150 cm) steel with 6 ball bearings, 5 bushings
Anti Vibration	Dual Isolation – grip and engine mount
Carburetor	Walbro – Choke Type
Ignition System	Solid State
Fuel Tank Capacity	1.05 qts. (1 liter)
Gas to Oil Ratio	50:1
Cutting Head	5" Semiautomatic
Weight	15.3 lbs. (6.9 kg)
Spark Plug	NGK BPM6Y
Spark Plug Gap	.024–.028 in (0.6–0.7mm)

# California Emission Control Warranty Statement

## Your Warranty Rights And Obligations

The California Air Resources Board and Toro are pleased to explain the emission control system warranty of your 1995 and later lawn and garden equipment engine. In California, new lawn and garden equipment engines must be designed, built and equipped to meet the State's stringent anti-smog standards. Toro must warrant the emission control system on your lawn and garden equipment engine for the periods of time listed below provided there has been no abuse, neglect or improper maintenance of your lawn and garden equipment engine.

Your emission control system may include parts such as the carburetor or fuel injection system, the ignition system, and catalytic converter. Also included may be hoses, belts, connectors and other emission-related assemblies.

Where a warrantable condition exists, Toro will repair your lawn and garden equipment engine at no cost to you including diagnosis, parts and labor.

The 1995 and later utility and lawn and garden equipment engines are warranted for two years. If any emission-related part on your engine is defective, the part will be repaired or replaced by Toro.

## Owner's Warranty Responsibilities:

- As the lawn and garden equipment engine owner, **you are responsible for the performance of the required maintenance listed in your Operator's manual.** Toro recommends that you retain all receipts covering maintenance on your lawn and garden equipment engine, but Toro cannot deny warranty solely for the lack of receipts or for your failure to ensure the performance of all scheduled maintenance.
- As the lawn and garden equipment engine owner, you should however be aware that Toro may deny you warranty coverage if your lawn and garden equipment engine or a part has failed due to abuse, neglect, improper maintenance or unapproved modifications.
- You are responsible for presenting your lawn and garden equipment engine to a Toro Authorized Service Dealer as soon as a problem exists. The warranty repairs should be completed in a reasonable amount of time, not to exceed **30 days**.

If you have any questions regarding your warranty rights and responsibilities, you should call 1-800-237-2654.

## Manufacturer's Warranty Coverage:

- The warranty period begins on the date the engine or equipment is delivered to the retail purchaser.
- The manufacturer warrants to the initial owner and each subsequent purchaser, that the engine is free from defects in material and workmanship which cause the failure of a warranted part for a period of two years.
- Repair or replacement of warranted part will be performed at no charge to the owner at an Authorized Toro Service Dealer. For the nearest location, please contact Toro at: 1-800-237-2654.
- Any warranted part which is not scheduled for replacement, as required maintenance which is scheduled only for regular inspection to the effect of "Repair or replace as necessary" is warranted for the warranty period. Any warranted part which is scheduled for replacement as required maintenance will be warranted for the period of time up to the first scheduled replacement point for that part.
- The owner will not be charged for diagnostic labor which leads to the determination that a warranted part is defective, if the diagnostic work is performed at an Authorized Toro Service Dealer.
- The manufacturer is liable for damages to other engine components caused by the failure of a warranted part still under warranty.
- Failures caused by abuse, neglect or improper maintenance are not covered under warranty.
- The use of add-on or modified parts can be grounds for disallowing a warranty claim. The manufacturer is not liable to cover failures or warranted parts caused by the use of add-on or modified parts.
- In order to file a claim, go to your nearest Authorized Toro Service Dealer. Warranty services or repairs will be provided at all Authorized Toro Service Dealers.
- Any manufacturer approved replacement part may be used in the performance of any warranty maintenance or repair of emission related parts and will be provided without charge to the owner. Any replacement part that is equivalent in performance or durability may be used in non-warranty maintenance or repair and will not reduce the warranty obligations of the manufacturer.
- The following components are included in the emission related warranty of the engine, air filter, carburetor, primer, fuel lines, fuel pick up/fuel filter, ignition module, spark plug and muffler.

PROTOTYPE



## THE TORO TOTAL COVERAGE GUARANTEE

A One-Year Limited Warranty  
(A Two-Year Full Warranty for Residential Use)

### What Is Covered By This Express Warranty?

The Toro Company promises to repair any TORO Product used for commercial, institutional, or rental purposes if defective in materials or workmanship for a period of one year from the date of purchase. The cost of parts and labor are included, but the customer pays the transportation cost. Transportation within a 15-mile radius of a TORO ProLine Service Dealer is covered under this warranty for Riding Products, Mid-size Mowers and Turf Maintenance Equipment.

### What Products Are Covered By This Warranty?

The following products and their attachments are covered by this warranty:

- Z-Master Zero Radius Tractors
- ProLine Mid-size Mowers
- Groundsmaster Riding Mowers
- ProLine Hand-held Gas Products
- Backpack Blowers
- Commercial WPM
- Turf Maintenance Equipment
- Debris Management Equipment

### How About Residential Use?

TORO Products used for residential use are covered by a full two-year warranty.

### How Do You Get Warranty Service?

Should you feel your TORO Product contains a defect in materials or workmanship, contact the dealer who sold you the product or any TORO ProLine Service Dealer. The Yellow Pages of your telephone directory is a good reference source; look under TORO Commercial Service Dealers. The Service Dealer will either arrange service at his/her dealership or recommend another authorized Service Dealer who may be more convenient. You may need proof of purchase (copy of registration card, sales receipt, etc.) for warranty validation.

If for any reason you are dissatisfied with a Service Dealer's analysis of the defect in materials or workmanship or if you need a referral to a TORO ProLine Service Dealer, please feel free to contact us at the following address:

Toro Customer Service Department  
8111 Lyndale Avenue South  
Bloomington, MN 55420-1196  
612-888-8801 or 800-348-2424

### What Must You Do To Keep The Warranty In Effect?

You must maintain your TORO Product by following the maintenance procedures described in the operator's manual. Such routine maintenance, whether performed by a dealer or by you, is at your expense.

### What Does This Warranty Not Cover? and

### How Does Your State Law Relate To This Warranty?

There is no other express warranty except for special emission system coverage on some products and as described above. This express warranty does not cover:

- Cost of regular maintenance service or parts, such as filters, fuel, lubricants, tune-up parts, blade sharpening, brake and clutch adjustments.
- Any product or part which has been altered or misused or required replacement or repair due to normal wear, accidents, or lack of proper maintenance.
- Repairs necessary due to improper fuel, contaminants in the fuel system, or failure to properly prepare the fuel system prior to any period of non-use over three months.
- Pickup and delivery charges for distances beyond a 15-mile radius from a TORO ProLine Service Dealer.

All repairs covered by this warranty must be performed by a TORO Service Dealer using Toro approved replacement parts.

**The Toro Company is not liable for indirect or consequential damages in connection with the use of the TORO Products covered by this warranty, including any cost or expense of providing substitute equipment or service during reasonable periods of malfunction or non-use pending completion of repairs under this warranty. Some states do not allow exclusions of incidental or consequential damages, so the above exclusion may not apply to you.**

**This warranty gives you specific legal rights, and you may also have other rights which vary from state to state.**

### COUNTRIES OTHER THAN THE UNITED STATES OR CANADA

Customers who have purchased TORO products exported from the United States or Canada should contact their TORO Distributor (Dealer) to obtain guarantee policies for your country, province, or state. If for any reason you are dissatisfied with your Distributor's service or have difficulty obtaining guarantee information, contact the TORO importer. If all other remedies fail, you may contact us at The Toro Company.