



Count on it.

Form No. 3394-897

Operator's Manual

Utility Task Vehicle (UTV)

Model No. UTV500AAC00000 - Serial No. 4UF15MPV3FT307514 and Up
Model No. UTV700AAC00000 - Serial No. 4UF15MPV2FT307524 and Up



[Register at www.Toro.com](http://www.Toro.com)
Original instructions (EN)



This vehicle can be hazardous to operate.

A collision or rollover can occur quickly, even during what you think are routine maneuvers such as driving or turning on flat terrain, driving on hills, or crossing obstacles, if you fail to take proper precautions. For your safety, understand and follow all the warnings contained in this Operator's Manual and the labels on this vehicle.

Keep this Operator's Manual with this vehicle at all times. The warning and instructional labels should be considered permanent parts of the vehicle. If a warning or instructional label comes off or becomes hard to read or you require a replacement manual, contact Toro for a free replacement. Contact The Toro Company Customer Care Department, RLC Division at 8111 Lyndale Ave. S, Bloomington, MN 55420.

FAILURE TO FOLLOW THE WARNINGS CONTAINED IN THIS MANUAL CAN RESULT IN SERIOUS INJURY OR DEATH.

Particularly important information is distinguished in this manual by the following notations:

	The Safety Alert Symbol means ATTENTION! BE ALERT! YOUR SAFETY IS INVOLVED.
	WARNING indicates a hazardous situation which, if not avoided, could result in death or serious injury.
	CAUTION, without the safety alert symbol, is used to address practices not related to personal injury.
■ NOTE:	A NOTE provides key information to make procedures easier or more clear.

FREE ROV TRAINING

Free training is available for Recreation Off-Highway Vehicles (ROV) operators and passengers from Recreational Off-Highway Vehicle Association (ROHVA). The Toro Company recommends that you complete this course before you first use your new ROV.

This web-based course takes approximately two hours to complete and presents you with a certificate of accomplishment as soon as you complete the course.

The course does not have to be completed all at one time. It will remember where you left off and bring you back to that point when you return.

To receive this free training, log on to www.ROHVA.org, click on "TAKE AN ROV E-COURSE FREE," and complete the course.

California Proposition 65

This product contains or emits chemicals known to the State of California to cause cancer and birth defects or other reproductive harm.

Always use common sense when operating this vehicle.

Foreword

Congratulations and thank you for purchasing a Toro UTV500/UTV700. Built with American engineering and manufacturing know-how, it is designed to provide superior ride, comfort, utility, and dependable service.

This vehicle is designed primarily as an off-road vehicle and is not intended for extensive use on public roads. When using the machine on public roads, follow all traffic regulations and use any additional accessories that may be required by law, such as lights, turn signals, and others as required.

This utility vehicle is intended to be used by professional, hired operators in commercial applications. This vehicle allows for the safe transport of an operator and passengers in the identified seats. The bed of this vehicle is not suitable for any riders.

This Operator's Manual is furnished to ensure that the operator is aware of safe operating procedures. It also includes information about the general care and maintenance of this vehicle.

Carefully read the following pages. If you have any questions regarding this vehicle, contact an authorized Toro ROV dealer for assistance. Remember, only authorized Toro ROV dealers have the knowledge and facilities to provide you with the best service possible.

Protect Your Sport

- Become familiar with all local and state/provincial laws governing ROV operation,
- Respect your vehicle,
- Respect the environment, and
- Respect private property and do not trespass.

We also advise you to strictly follow the recommended maintenance program as outlined. This preventive maintenance program is designed to ensure that all critical components on this vehicle are thoroughly inspected at various intervals.

All information in this manual is based on the latest product data and specifications available at the time of printing. The Toro Company reserves the right to make product changes and improvements which may affect illustrations or explanations without notice.

You have chosen a quality Toro product designed and manufactured to give dependable service. Be sure, as the owner/operator of this vehicle, to become thoroughly familiar with its basic operation, maintenance, and storage procedures. Read and understand the entire Operator's Manual before operating this vehicle to ensure safe and proper use. Always operate the vehicle within your level of skill and current terrain conditions.

Division II of this manual covers operator-related maintenance, operating instructions, and storage instructions. If major repair or service is ever required, contact an authorized Toro ROV dealer for professional service.

At the time of publication, all information and illustrations in Division II were technically correct. Some illustrations used in Division II are used for clarity purposes only and are not designed to depict actual conditions. Because The Toro Company constantly refines and improves its products, no retroactive obligation is incurred.

Parts and Accessories

When in need of replacement parts, oil, or accessories for this vehicle, be sure to use only GENUINE Toro PARTS, OIL, AND ACCESSORIES. Only genuine Toro parts, oil, and accessories are engineered to meet the standards and requirements of this vehicle. For a complete list of accessories, refer to the current Toro ROV Accessory Catalog.

To aid in service and maintenance procedures on this vehicle, a Service Manual is available through your local Toro ROV dealer and an Illustrated Parts Manual is available at www.Toro.com.

Operation of this vehicle is restricted to people 16 years of age and older who possess a valid driver's license. Passengers must be able to place both feet flat on the floor while keeping their back against the back of the seat and the outboard passenger must hold on to an available hand hold.

Table of Contents

Foreword.....	1	General Lubrication	39
Parts and Accessories	1	Hydraulic Brake	41
DIVISION I - SAFETY		Protective Rubber Boots.....	42
Safety Alert.....	4	Battery.....	43
Warning and Instructional Labels	5-6	Spark Plug.....	45
Location of Parts and Controls	7	Air Inlet Pre-Filter	45
Warnings	8-16	Air Filter	46
DIVISION II -		Air Filter Housing Drains	47
OPERATION/		Draining V-Belt Cover	47
MAINTENANCE		Tires	47
Specifications	17	Wheels	48
Vehicle Operation	18-23	Muffler/Spark Arrester	48
General Information.....	24-35	Light Bulb Replacement	49
Control Locations and Functions	24	Checking/Adjusting Headlight Aim ...	50
Occupant Side Restraints	26	Fuses.....	50
Cargo Box	26	Electrical Output Terminals.....	51
Speedometer/LCD	29	Storage Compartment/Tools.....	51
Electric Fuel Pump.....	31	Seat Belts	51
Gas Hoses	31	Occupant Side Restraints.....	51
Oil Level Stick.....	31	ROPS	51
Load Capacity Ratings.....	32	Preparation for Storage	52
Trailer and Towing.....	32	Preparation after Storage.....	53
Transporting	33	Limited Warranty	54
Gasoline-Oil-Lubricant	34	Warranty Procedure/Owner	
Engine Break-In	35	Responsibility.....	55
Burnishing Brake Pads.....	35	U.S. EPA Emission Control Statement/	
General Maintenance.....	36-51	Warranty Coverage (U.S. Only).....	56
Maintenance Schedule	37	Maintenance Record	57
Liquid Cooling System	38	Change of Address, Ownership, or	
Shock Absorbers.....	38	Warranty Transfer	59
		Identification Numbers Record Inside	
		Back Cover	

DIVISION I - SAFETY

This vehicle is not a toy and can be hazardous to operate.

■ **NOTE:** To view important safety information, please log on to www.toro.com/en-us/safety (USA) or www.toro.com/en-ca/safety (Canada).

- Always go slowly and be extra careful when operating on unfamiliar terrain. Always be alert to changing terrain conditions when operating this vehicle.
- Never operate on excessively rough, slippery, or loose terrain.
- Always follow proper procedures for turning as described in this manual. Practice turning at slow speeds before attempting to turn at faster speeds. Do not turn at excessive speed.
- Always have the vehicle checked by an authorized Toro ROV dealer if it has been involved in an accident.
- Never operate on hills too steep for your abilities. Practice on smaller hills before attempting larger hills.
- Always follow proper procedures for climbing hills as described in this manual. Check the terrain carefully before you start up any hill. Never climb hills with slippery or loose surfaces. Never depress the accelerator suddenly or make gear changes while moving. Never go over the top of any hill at high speed.
- Always follow proper procedures for going down hills and for braking on hills as described in this manual. Check the terrain carefully before you start down any hill. Never go down a hill at high speed. Avoid going down a hill at an angle which would cause the vehicle to lean sharply to one side. Go straight down the hill where possible.
- Always be careful when you decide to climb or descend a hill and never turn on a hill. Drive straight up or down inclines and not across them. If you must cross the side of a hill, drive slowly and stop or turn downhill if you feel the vehicle may tip over.
- Always use proper procedures if you stall or roll backward when climbing a hill. To avoid stalling, maintain a steady speed when climbing a hill. If you stall or roll backwards, follow the special procedure for braking described in this manual.
- Always check for obstacles before operating in a new area. Never attempt to operate over large obstacles, such as large rocks or fallen trees. Always follow proper procedures when operating over obstacles as described in this manual.
- Always be careful of skidding or sliding. On slippery surfaces, such as ice, go slowly and be very cautious in order to reduce the chance of skidding or sliding out of control.
- Never operate this vehicle in fast flowing water or in water deeper than the floorboard. Wet brakes may have reduced stopping capability. Test your brakes after leaving water. If necessary, apply them lightly several times to let friction dry out the pads.
- Always be sure there are no obstacles or people behind you when you operate in reverse. When it is safe to proceed in reverse, look behind you and go slowly. Avoid turning at sharp angles in reverse.
- Always use the size and type tires specified in this manual. Always maintain proper tire pressure as described in this manual.
- Never improperly install or improperly use accessories on this vehicle.
- Never exceed the stated load capacity for this vehicle. Cargo should be properly distributed and securely attached. Reduce speed and follow instructions in this manual for carrying cargo or pulling a trailer and allow greater distance for braking.
- Operation of this vehicle is restricted to people 16 years of age and older who possess a valid driver's license. Passengers must be able to place both feet flat on the floor while keeping their back against the back of the seat and the outboard passenger must hold on to the hand hold.



WARNING

Indicates a hazardous situation which, if not avoided, could result in death or serious injury.

3

Safety Alert

You should be aware that THIS VEHICLE IS NOT A TOY AND CAN BE HAZARDOUS TO OPERATE. This vehicle handles differently from other vehicles, including motorcycles and cars. A collision or rollover can occur quickly, even during what you think are routine maneuvers such as turning, driving on hills, and going over obstacles, if you fail to take proper precautions.

TO AVOID SERIOUS INJURY OR DEATH:

- * Always read the Operator's Manual carefully and follow the operating procedures described. Pay special attention to the warnings contained in the manual and on all labels.
- * Always wear the seat belt when operating or riding in this vehicle.
- * Always follow these age recommendations:
 - Operation of this vehicle is restricted to people 16 years of age and older who possess a valid driver's license. Passengers must be able to place both feet flat on the floor while keeping their back against the back of the seat and the outboard passenger must hold on to available hand hold.
- * Never carry a passenger in the cargo box of this vehicle.
- * Never operate this vehicle on a public road, even a dirt or gravel one, because you may not be able to avoid colliding with other vehicles.
- * Never operate this vehicle without an approved motorcycle helmet, eye protection, boots, gloves, long pants and a long-sleeved shirt or jacket.
- * Never consume alcohol or drugs before or while operating this vehicle.
- * Never operate this vehicle at excessive speeds. Go at a speed which is proper for the terrain, visibility conditions, and your experience.
- * Never attempt to do wheelies, jumps, or other stunts.
- * Always be careful when operating this vehicle, especially when approaching hills, turns, and obstacles and when operating on unfamiliar or rough terrain.
- * Never operate this vehicle with the cargo box lifted or removed.
- * Never operate this vehicle in fast flowing water or in water deeper than the floorboard.
- * Never operate this vehicle with the ROPS removed. The ROPS provides a structure helping to limit intrusions by branches or other objects and may reduce your risk of injury in accidents.
- * Never put your hands or feet outside the vehicle for any reason while the vehicle is in motion. Do not hold onto the ROPS or hip restraint bar. If you think or feel the vehicle may tip, do not put your hands or feet outside the vehicle as they will not be able to prevent the vehicle from tipping. Any part of your body (arms, legs, or head) outside the vehicle can be crushed by passing objects, the vehicle, or ROPS.
- * Always fasten occupant side restraints prior to moving the vehicle.

4



WARNING

Indicates a hazardous situation which, if not avoided, could result in death or serious injury.

Warning and Instructional Labels

A

⚠ WARNING

Exceeding vehicle's towing limit could cause an accident. Reduce speed when towing a trailer. Do not tow in reverse over 5 mph. High speed will result in loss of control. Read owner's manual for details.

MAXIMUM TONGUE WEIGHT:
150 lbs (68 kg)

MAXIMUM TOWING CAPACITY:
1500 lbs (680 kg)

1411-122

E

⚠ WARNING



Watch hands while closing cargo box.

4411-982

B

⚠ WARNING



- Keep hands, body and other persons away from closing cargo box.
- Do not operate the vehicle with cargo box up.

1411-123

D

⚠ WARNING

Vehicle rollover could cause **SERIOUS INJURY** or **DEATH**. You must keep all parts of your body inside the vehicle.

DO NOT remove this ROPS.

This ROPS complies with ISO 3471.

3411-970

C

⚠ WARNING

Do not run engine without this shield in place or with drive belt removed.

Do not attempt any adjustment with engine running.

0811-426

F

(500)

⚠ WARNING

IMPROPER TIRE PRESSURE OR OVERLOADING CAN CAUSE LOSS OF CONTROL.

LOSS OF CONTROL CAN RESULT IN SEVERE INJURY OR DEATH.

COLD TIRE PRESSURE:
FRONT: 16 psi (110 kPa)
REAR: 16 psi (110 kPa)
MAXIMUM WEIGHT CAPACITY: 1100 lbs (479 kg)

⚠ WARNING

DRIVING ACROSS THE SIDE OF AN INCLINE INCREASES THE RISK OF OVERTURN.

LOADING/TRAILER TOWING
CARGO OR TRAILER CAN AFFECT STABILITY AND HANDLING.

WHEN LOADED WITH CARGO OR TOWING A TRAILER:
-REDUCE SPEED.
-ALLOW MORE ROOM TO STOP.
-AVOID HILLS, ROUGH TERRAIN, RUTS AND PAVED SURFACES.
-OPERATE IN LOW RANGE GEARS ONLY.

NEVER EXCEED THE VEHICLE LOAD CAPACITY INCLUDES WEIGHT OF OPERATOR, PASSENGER, CARGO, ACCESSORIES, AND TRAILER TONGUE.
MAXIMUM LOAD IN CARGO BED: 600 lbs (272 kg)
NEVER WHEN LOADED, BACK DOWN A SLOPE AND APPLY BRAKES OR ACCELERATE UPHILL.

1411-124

(700)

⚠ WARNING

IMPROPER TIRE PRESSURE OR OVERLOADING CAN CAUSE LOSS OF CONTROL.

LOSS OF CONTROL CAN RESULT IN SEVERE INJURY OR DEATH.

COLD TIRE PRESSURE:
FRONT: 20 psi (137 kPa)
REAR: 20 psi (137 kPa)
MAXIMUM WEIGHT CAPACITY: 1500 lbs (680 kg)

⚠ WARNING

DRIVING ACROSS THE SIDE OF AN INCLINE INCREASES THE RISK OF OVERTURN.

LOADING/TRAILER TOWING
CARGO OR TRAILER CAN AFFECT STABILITY AND HANDLING.

WHEN LOADED WITH CARGO OR TOWING A TRAILER:
-REDUCE SPEED.
-ALLOW MORE ROOM TO STOP.
-AVOID HILLS, ROUGH TERRAIN, RUTS AND PAVED SURFACES.
-OPERATE IN LOW RANGE GEARS ONLY.

NEVER EXCEED THE VEHICLE LOAD CAPACITY INCLUDES WEIGHT OF OPERATOR, PASSENGER, CARGO, ACCESSORIES, AND TRAILER TONGUE.
MAXIMUM LOAD IN CARGO BED: 1000 lbs (453 kg)
[CALIFORNIA MODEL S 600 lbs (272 kg)]
NEVER WHEN LOADED, BACK DOWN A SLOPE AND APPLY BRAKES OR ACCELERATE UPHILL.

1411-125

G

CAUTION

Increasing engine RPM above idle while in park will cause belt damage.

1411-500

H

⚠ WARNING

NEVER exceed 10 MPH (16KPH) when differential is LOCKED. Loss of control and Severe Injury or Death may result at high speeds when differential is LOCKED.

1411-124

I

*** IMPORTANT ***

USE ONLY COOLANTS APPROVED BY O.E.M. MFG'S FOR ALUMINUM RADIATORS.



HDX191D

Pour commander des Etiquettes de Mise en Garde gratuites, voyez votre détaillant de autorisé VTT Toro pour le numéro de pièce 1436-444.

⚠ WARNING Indicates a hazardous situation which, if not avoided, could result in death or serious injury. **5**

Warning and Instructional Labels

B **⚠ WARNING**

Exceeding vehicle's towing limit could cause an accident. Reduce speed when towing a trailer. Read owner's manual for details.

MAXIMUM TONGUE WEIGHT: 150 lbs (68 kg)
 MAXIMUM TOWING CAPACITY: 1500 lbs (680 kg) 2411-234

E **⚠ WARNING**

IMPROPER USE OF OFF-HIGHWAY VEHICLES CAN CAUSE SEVERE INJURY OR DEATH.

BE PREPARED

- FASTEN SEAT BELTS.
- WEAR AN APPROVED HELMET AND PROTECTIVE GEAR.
- MAKE SURE ALL SIDE RESTRAINTS ARE FULLY LATCHED.
- EACH RIDER MUST BE ABLE TO SIT BACK AGAINST SEAT. FEET FLAT ON FLOOR, AND HANDS ON STEERING WHEEL OR HANDHOLD WHERE EQUIPPED. STAY COMPLETELY INSIDE VEHICLE.

REQUIRE PROPER USE OF YOUR VEHICLE. DO YOUR PART TO PREVENT INJURIES:

- DO NOT ALLOW CARELESS OR RECKLESS DRIVING.
- MAKE SURE OPERATORS ARE 16 OR OLDER WITH A VALID DRIVER'S LICENSE.
- DO NOT LET PEOPLE DRIVE OR RIDE AFTER USING ALCOHOL OR DRUGS.
- DO NOT ALLOW OPERATION ON PUBLIC ROADS (UNLESS DESIGNATED FOR OFF-HIGHWAY VEHICLE ACCESS). COLLISIONS WITH CARS AND TRUCKS CAN OCCUR.
- DO NOT EXCEED SEATING CAPACITY: 2 PASSENGERS.

BE SURE RIDERS PAY ATTENTION AND PLAN AHEAD IF YOU THINK OR FEEL THE VEHICLE MAY TIP OR ROLL. REDUCE YOUR RISK TO INJURY.

- KEEP A FIRM GRIP ON THE STEERING WHEEL OR HANDHOLDS AND BRACE YOURSELF.
- DO NOT PUT ANY PART OF YOUR BODY OUTSIDE OF THE VEHICLE FOR ANY REASON.

⚠ WARNING

FAILURE TO STOP VEHICLE COMPLETELY BEFORE ENGAGING REVERSE COULD RESULT IN RIDERS BEING THROWN FROM THE VEHICLE.

TO ENGAGE REVERSE:

1. STOP VEHICLE COMPLETELY.
2. BRING ENGINE TO IDLE WHILE APPLYING BRAKE.
3. SHIFT TRANSMISSION INTO REVERSE WHILE APPLYING BRAKE.

WHEN STOPPED:

PUT GEAR SELECTOR IN PARK BEFORE LEAVING THE VEHICLE.

3411-631

D (500)

⚠ WARNING

SEVERE INJURY OR DEATH can result if you ignore the following:

- Maximum load in cargo bed: 600 lbs (272 kg)
- Be sure cargo is secured, a loose load could shift and change handling unexpectedly.
- Keep weight in the cargo bed centered, low and forward. Top-heavy load increase the risk of overturn.
- Never carry passengers in cargo bed.

1431-119

(700)

⚠ WARNING

SEVERE INJURY OR DEATH can result if you ignore the following:

- Maximum load in cargo bed: 1000 lbs (454 kg) [California models 600 lbs (272 kg)]
- Be sure cargo is secured, a loose load could shift and change handling unexpectedly.
- Keep weight in the cargo bed centered, low and forward. Top-heavy load increase the risk of overturn.
- Never carry passengers in cargo bed.

4411-107

C

⚠ WARNING

APPROPRIATE USE OF OFF-HIGHWAY VEHICLES TO AVOID SEVERE INJURY OR DEATH. BEVEL RESPONSIBILITY.

ADVICE: LOAD OF CARGO AND FOLLOWING WEIGHT DISTRIBUTION, BEING EXCESSIVE, BEYOND CAPACITY OF FRAME AND WEIGHT DISTRIBUTION, CAN CAUSE VEHICLE TO TIP OR ROLL OVER. ALWAYS USE PROPER TIE-DOWN TECHNIQUE TO SECURE CARGO. ALWAYS USE HELMETS, SEATBELTS, AND SAFETY BELTS. ALWAYS WEAR YOUR SEATBELT. ALWAYS WEAR YOUR HELMET. ALWAYS WEAR YOUR HELMET. ALWAYS WEAR YOUR HELMET. ALWAYS WEAR YOUR HELMET.

ALWAYS USE AN APPROVED HELMET AND PROTECTIVE GEAR AND PROTECTIVE SEAT BELT.

ALWAYS WEAR YOUR SEATBELT OR SAFETY BELT.

ALWAYS WEAR YOUR HELMET.

A

STARTING INSTRUCTIONS:

1. Engage foot brake or move shift lever to **NEUTRAL**.
2. To start engine, turn ignition switch clockwise for a maximum of 8 seconds. If engine does not start, repeat above procedure 2 additional times.
3. Allow the engine to warm up for 2-3 minutes or until engine will accelerate without hesitating.

2415-311



HDX189A

6 **⚠ WARNING** Indicates a hazardous situation which, if not avoided, could result in death or serious injury.

Location of Parts and Controls



HDX184A



TC001A

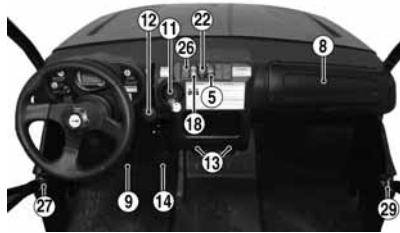

TC002A



TC003A

1. Battery
2. Headlights
3. Tool Kit
4. Tailgate Latch
5. Reverse Override Switch
6. Outboard Passenger Hand Hold
7. Hip Restraint Bar
8. In-Dash Storage Compartment
9. Brake Pedal
10. Fuses
11. Ignition/Start Switch
12. Shift Lever
13. DC Power Outlets
14. Accelerator Pedal
15. Cargo Box Latch Handle
16. Taillight/Brakelight
17. Operator's Manual Location
18. Headlight Switch
19. Driver Seat Belt
20. Passenger Seat Belt (Right)
21. Passenger Seat Belt (Center)
22. Drive Select Switch
23. Occupant Side Restraints
24. Hitch Receiver
25. Gas Tank Cap
26. Seat Belt Reminder Indicator Light
27. Occupant Side Restraint Latch
28. Cargo Box Handle
29. Passenger Side Restraint Latch

■ **NOTE: The vehicle you purchased may differ slightly from those shown in the figures of this manual.**

WARNING

Indicates a hazardous situation which, if not avoided, could result in death or serious injury.

Warnings

WARNING

POTENTIAL HAZARD

Operating this vehicle without proper instruction.

WHAT CAN HAPPEN

The risk of an accident is greatly increased if the operator does not know how to operate this vehicle properly in different situations and on different types of terrain.

HOW TO AVOID THE HAZARD

All operators of this vehicle must read and understand this Operator's Manual and all warning and instruction labels prior to operating this vehicle.

WARNING

POTENTIAL HAZARD

Allowing anyone under age 16 to operate this vehicle.

WHAT CAN HAPPEN

Use of this vehicle by children can lead to serious injury or death of the child. Children under the age of 16 may not have the skills, abilities, or judgment needed to operate this vehicle safely and may be involved in a serious accident.

HOW TO AVOID THE HAZARD

Only people 16 years of age or older with a valid driver's license should operate this vehicle.

WARNING

POTENTIAL HAZARD

Allowing passengers to ride in the cargo bed.

WHAT CAN HAPPEN

Serious injury or death. This vehicle is not designed to carry passengers in the cargo bed. Passengers in the cargo bed can be thrown around or from the vehicle during operation or in an accident.

HOW TO AVOID THE HAZARD

Do not permit passengers to ride in the cargo bed. Do not install any seating in the cargo bed.

WARNING

POTENTIAL HAZARD

Operating this vehicle on public streets, roads, or highways.

WHAT CAN HAPPEN

You can collide with another vehicle.

HOW TO AVOID THE HAZARD

Never operate this vehicle on any public street, road, or highway. In many states it is illegal to operate a vehicle of this type on public streets, roads, or highways. Always check state and local laws and regulations.

8

WARNING

Indicates a hazardous situation which, if not avoided, could result in death or serious injury.

Warnings

WARNING

POTENTIAL HAZARD

Operating this vehicle without wearing an approved helmet, eye protection, and protective clothing.

WHAT CAN HAPPEN

Operating without an approved helmet increases your chances of a serious head injury or death in the event of an accident.

Operating without eye protection can result in an accident and increases your chances of a serious injury in the event of an accident.

Operating without protective clothing increases your chances of serious injury in the event of an accident.

HOW TO AVOID THE HAZARD

Always wear an approved helmet that fits properly.

You should also wear:

Eye protection (goggles or face shield)

Gloves

Boots

Long sleeved shirt or jacket

Long pants

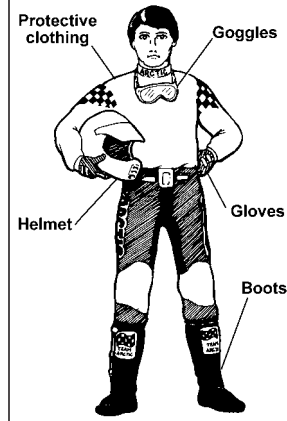

WARNING

POTENTIAL HAZARD

Operating this vehicle after or while consuming alcohol or drugs.

WHAT CAN HAPPEN

Could seriously affect your judgment.

Could cause you to react more slowly.

Could affect your balance and perception.

Could result in an accident.

HOW TO AVOID THE HAZARD

Never consume alcohol or drugs before or while driving this vehicle.

WARNING

POTENTIAL HAZARD

Operating or riding in the vehicle without wearing a properly-secured seat belt.

WHAT CAN HAPPEN

Serious injury or death. Occupants can strike objects in the passenger compartment, fall out of the vehicle during maneuvers, or be crushed or otherwise injured in the event of an accident.

HOW TO AVOID THE HAZARD

ALWAYS WEAR YOUR SEAT BELT and require others to wear their seat belts. See the Operation/Maintenance section of this manual for more information on using your seat belt and both operator and passenger(s) wearing an approved helmet.

WARNING

Indicates a hazardous situation which, if not avoided, could result in death or serious injury.

Warnings

WARNING

POTENTIAL HAZARD

Operating or riding in the vehicle without occupant side restraints properly secured.

WHAT CAN HAPPEN

Serious injury or death. Occupants or their body parts can strike objects outside the vehicle, be crushed by the vehicle, or fall out of the vehicle during maneuvers or in the event of an accident.

HOW TO AVOID THE HAZARD

Do not remove the occupant side restraints. Make sure both driver and passenger occupant side restraints are secure before operating or riding in the vehicle. Stay seated with your seat belt and helmet on and keep your body completely inside the vehicle during operation. See the Operation/Maintenance section of this manual for more information.

WARNING

POTENTIAL HAZARD

Failing to keep all parts of your body inside the passenger compartment during operation.

WHAT CAN HAPPEN

Serious injury or death. Body parts could strike objects outside of vehicle or be crushed in the event of a rollover or accident.

HOW TO AVOID THE HAZARD

Do not place your head, arms, hands, legs, or feet outside of the passenger compartment during operation. Stay seated with your seat belt and helmet on and occupant side restraints properly secured. Keep your feet and legs inboard of the foot restraints at all times. Do not attempt to stop movement or tipping of the vehicle with your hands or feet. Keep all body parts inside the passenger compartment. If you feel the vehicle tipping, brace your feet flat on the floor and keep hands firmly gripping the steering wheel and the outboard passenger must hold on to the hand hold.

WARNING

POTENTIAL HAZARD

Operating this vehicle at excessive speeds.

WHAT CAN HAPPEN

Increases your chances or losing control of the vehicle, which can result in an accident.

HOW TO AVOID THE HAZARD

Always ride at a speed that is proper for the terrain, visibility, load, and operating conditions.

Warnings

WARNING

POTENTIAL HAZARD

Attempting wheelies, jumps, and other stunts.

WHAT CAN HAPPEN

Increases the chance of an accident including a rollover.

HOW TO AVOID THE HAZARD

Never attempt stunts, such as wheelies or jumps. Don't try to show off.

WARNING

POTENTIAL HAZARD

Failure to inspect this vehicle before operating.

Failure to properly maintain this vehicle.

WHAT CAN HAPPEN

Increases the possibility of an accident or equipment damage.

HOW TO AVOID THE HAZARD

Always inspect this vehicle each time you use it to make sure it is in safe operating condition.

Always follow the inspection and maintenance procedures and schedules described in this Operator's Manual.

WARNING

POTENTIAL HAZARD

Failure to use extra care when operating this vehicle on unfamiliar terrain.

WHAT CAN HAPPEN

You can come upon hidden rocks, bumps, or holes without enough time to react.

Could result in the vehicle overturning or going out of control.

HOW TO AVOID THE HAZARD

Go slowly and be extra careful when operating on unfamiliar terrain.

Always be alert to changing terrain conditions when operating this vehicle.

WARNING

POTENTIAL HAZARD

Failure to use extra care when operating on rough, slippery, or loose terrain.

WHAT CAN HAPPEN

Could cause loss of traction or control, which could result in an accident including a rollover.

HOW TO AVOID THE HAZARD

Do not operate on rough, slippery, or loose terrain until you have learned and practiced the skills necessary to control this vehicle on such terrain.

Always be especially cautious on these kinds of terrain.

WARNING

Indicates a hazardous situation which, if not avoided, could result in death or serious injury. **11**

Warnings

WARNING

POTENTIAL HAZARD

Failing to use care in turns; turning too sharply or aggressively.

WHAT CAN HAPPEN

The vehicle could go out of control causing a collision, tip over, or rollover.

HOW TO AVOID THE HAZARD

Always follow proper procedures for turning as described in this Operator's Manual. Practice turning at slow speeds before attempting to turn at faster speeds. Do not turn at excessive speed or too sharply for the conditions and for your experience level. See the Operation/Maintenance section of this manual for more information on turning on flat ground, hills, sand, ice, mud, or water.

WARNING

POTENTIAL HAZARD

Operating on steep hills.

WHAT CAN HAPPEN

This vehicle can overturn more easily on steep hills than on level surfaces or small hills.

HOW TO AVOID THE HAZARD

Never operate the vehicle on hills too steep for the vehicle or for your abilities. Practice on smaller hills before attempting larger hills.

WARNING

POTENTIAL HAZARD

Operating with the ROPS removed.

WHAT CAN HAPPEN

Could lead to serious injury or death.

HOW TO AVOID THE HAZARD

Never operate this vehicle with the ROPS removed.

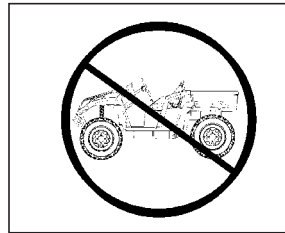

WARNING

POTENTIAL HAZARD

Going down a hill improperly.

WHAT CAN HAPPEN

Could cause loss of control or cause the vehicle to overturn.

HOW TO AVOID THE HAZARD

Always follow proper procedures for going down hills as described in this Operator's Manual.

Always check the terrain carefully before you start down any hill.

Never go down a hill at high speed.

Avoid going down a hill at an angle that would cause the vehicle to lean sharply to one side. Go straight down the hill where possible.



Warnings

WARNING

POTENTIAL HAZARD

Climbing hills improperly.

WHAT CAN HAPPEN

Could cause loss of control or cause the vehicle to overturn.

HOW TO AVOID THE HAZARD

Always follow proper procedures for climbing hills as described in this Operator's Manual.

Always check the terrain carefully before you start up any hill.

Never climb hills with slippery or loose surfaces.

Never open the throttle suddenly or make sudden gear changes. The vehicle could flip over backwards.

Never go over the top of any hill at high speed. An obstacle, a sharp drop, or another vehicle or person could be on the other side of the hill.



Never Operate Up Or Down Hills Steeper Than 15°



WARNING

POTENTIAL HAZARD

Crossing hills or turning on hills.

WHAT CAN HAPPEN

Could cause loss of control or cause the vehicle to overturn.

HOW TO AVOID THE HAZARD

Never attempt to turn the vehicle around on any hill. If you must cross the side of a hill, drive slowly and stop or turn downhill if you feel the vehicle may tip.

WARNING

POTENTIAL HAZARD

Stalling, rolling backwards, or improperly dismounting while climbing a hill.

WHAT CAN HAPPEN

Could result in the vehicle overturning.

HOW TO AVOID THE HAZARD

Use proper gear and maintain steady speed when climbing a hill.

If you lose all forward speed:

Apply the brakes. Place the transmission in park after you are stopped.

If you begin rolling backwards:

Apply the brakes while rolling backwards. When fully stopped, shift the transmission into park.

WARNING

Indicates a hazardous situation which, if not avoided, could result in death or serious injury.

Warnings

WARNING

POTENTIAL HAZARD

Improperly operating in reverse.

WHAT CAN HAPPEN

You could hit an obstacle or person behind you, resulting in serious injury or death.

HOW TO AVOID THE HAZARD

Before you engage reverse gear, make sure there are no obstacles or people behind you. When it is safe to proceed, go slowly.

WARNING

POTENTIAL HAZARD

Improperly operating over obstacles.

WHAT CAN HAPPEN

Could cause loss of control or a collision. Could cause the vehicle to overturn.

HOW TO AVOID THE HAZARD

Before operating in a new area, check for obstacles.

Never attempt to ride over large obstacles, such as large rocks or fallen trees.

When you go over obstacles, always follow proper procedures as described in this Operator's Manual.

WARNING

POTENTIAL HAZARD

Skidding or sliding.

WHAT CAN HAPPEN

You could lose control of the vehicle.

You could also regain traction unexpectedly, which may cause the vehicle to overturn.

HOW TO AVOID THE HAZARD

Learn to safely control skidding or sliding by practicing at slow speeds and on level, smooth terrain.

On extremely slippery surfaces, such as ice, go slowly and be very cautious in order to reduce the chance of skidding or sliding out of control.

WARNING

POTENTIAL HAZARD

Operating the vehicle with improper tires or with improper or uneven tire pressure.

WHAT CAN HAPPEN

Use of improper tires on the vehicle, or operating the vehicle with improper or uneven tire pressure, could cause loss of control increasing your risk of accident.

HOW TO AVOID THE HAZARD

Always use the size and type tires specified in this Operator's Manual for this vehicle.

Always maintain proper tire pressure as described in this Operator's Manual.



Warnings

WARNING

POTENTIAL HAZARD

Overloading the vehicle or carrying or towing cargo improperly.

WHAT CAN HAPPEN

Could cause changes in handling, which could lead to an accident.

HOW TO AVOID THE HAZARD

Never exceed the stated load capacity for this vehicle.

Cargo should be properly distributed and securely attached.

Reduce speed when carrying cargo or pulling a trailer. Allow greater distance for braking.

Always follow the instructions in this Operator's Manual for carrying cargo or pulling a trailer.

WARNING

POTENTIAL HAZARD

Operating this vehicle through deep or fast flowing water.

WHAT CAN HAPPEN

Tires may float, causing loss of traction and loss of control, which could lead to an accident.

HOW TO AVOID THE HAZARD

Never operate this vehicle in fast flowing water or in water deeper than the floorboard.

Remember that wet brakes may have reduced stopping capability.

Test the brakes after leaving water. If necessary, apply them several times to dry out the pads.

WARNING

POTENTIAL HAZARD

Operating this vehicle with improper modifications.

WHAT CAN HAPPEN

Improper installation of accessories or modification of the vehicle may cause changes in handling which, in some situations, could lead to an accident.

HOW TO AVOID THE HAZARD

Never modify this vehicle through improper installation or improper use of accessories.

All parts and accessories added to this vehicle should be genuine Toro components designed for use on this vehicle and should be installed and used according to instructions. If you have questions, consult an authorized Toro ROV dealer.

WARNING

Indicates a hazardous situation which, if not avoided, could result in death or serious injury.

Warnings

WARNING

POTENTIAL HAZARD

Operating through or over thick or sharp brush, timber, debris, or rocks.

WHAT CAN HAPPEN

Serious injury or death. Brush, branches, debris, and rocks can enter or penetrate the passenger compartment and strike occupants. Running over sharp branches, rocks, or other large objects can also cause loss of control.

HOW TO AVOID THE HAZARD

Be alert. Slow down. Wear all recommended protective gear specified in this Operator's Manual. Avoid operating through or over thick brush, timber, debris, or large rocks whenever possible. Watch for and avoid sharp branches, rocks, or other large objects that could impede or impact the vehicle or enter the passenger compartment.

WARNING

POTENTIAL HAZARD

Operating the vehicle with differential lock engaged.

WHAT CAN HAPPEN

The increased steering effort and reduced maneuverability caused by the locked differential could result in loss of control and an accident.

HOW TO AVOID THE HAZARD

Never exceed 10 MPH (16 KPH) with the differential lock engaged. Always disengage the differential lock as soon as not needed for additional traction.

WARNING

POTENTIAL HAZARD

Failing to avoid pinch-points when lowering the cargo box.

WHAT CAN HAPPEN

Fingers, hands, or arms could be seriously injured when lowering the cargo box.

HOW TO AVOID THE HAZARD

Always be aware of and avoid lowering cargo box until everyone is clear of pinch-points.

WARNING

POTENTIAL HAZARD

Securing a person improperly in the vehicle due to physical size.

WHAT CAN HAPPEN

Serious injury or death. Occupant could strike objects in the passenger compartment, fall out of the vehicle during maneuvers, or be ejected and crushed in the event of an accident.

HOW TO AVOID THE HAZARD

Always make sure a passenger can sit with both feet flat on the floor and their back against the seat while being able to reach any provided hand holds.

DIVISION II - OPERATION/ MAINTENANCE Specifications

ENGINE	
Type	Four-Cycle/Liquid Cooled
Bore x Stroke	89 mm x 71.12 mm (3.5 x 2.8 in.) - 500 102 mm x 85 mm (4.01 x 3.4 in.) - 700
Displacement	442 cc (27 cu in.) - 500 695 cc (42.4 cu in.) - 700
Spark Plug Type	NGK CR7E - 500 NGK CPR8E - 700
Spark Plug Gap	0.7-0.8 mm (0.028-0.031 in.) - 500 0.5-0.6 mm (0.019-0.024 in.) - 700
Brake Type	Hydraulic Disc/Rear Driveline - 500 Four Wheel Hydraulic - 700
CHASSIS	
Length (Overall)	327.6 cm (129.0 in.)
Height (Overall)	200.6 cm (79.0 in.)
Width (Overall)	152.4 cm (60 in.)
Suspension Travel (Front/Rear)	25.4 cm (10 in.)
Tire Size (Front)	26 x 9R-14
Tire Size (Rear)	26 x 11R-14
Tire Inflation Pressure	110 kPa (16 psi) - 500 138 kPa (20 psi) - 700
MISCELLANY	
Dry Weight (Approx)	592 kg (1307 lb) - 500 618 kg (1363 lb) - 700
ROPS Tested Curb Weight	680 kg (1500 lb)
Gas Tank Capacity	31 L (8.2 U.S. gal.)
Coolant Capacity	2.9 L (3.0 U.S. qt)
Differential Capacity	275 ml (9.3 fl oz)
Rear Drive Capacity	250 ml (8.5 fl oz)
Engine Oil Capacity (Approx)	2.8 L (3.0 U.S. qt) - 500 1.9 L (2.0 U.S. qt) - 700
Gasoline (Recommended)	87 Octane Regular Unleaded
Engine Oil (Recommended)	Toro 0W-40 All Weather Synthetic
Front Differential/Rear Drive Lubricant	SAE Approved 80W-90 Hypoid
Brake Fluid	DOT 4 Approved
Taillight/Brakelight	12V/8W/27W
Headlight	12V/27W (4)
Starting System	Electric

Specifications subject to change without notice.

Vehicle Operation

Pre-Start/Pre-Operation Checklist	
Item	Remarks
Brake System	Pedal firm - near top of travel. Fluid at proper level. Check for fluid leaks.
Controls	Steering free - no binding - no excessive free-play. Shift lever in park. Accelerator free - no binding - returns to idle position.
Fluids	Coolant level to the bottom of the stand pipe in the radiator neck. Check oil level. Gas tank full of recommended gasoline. Differential/rear drive at proper level. Check for fluid leaks.
Suspension	Ball joints/tie rod ends free - secure. Shocks not leaking - mountings secure. Shock spring pre-load equal on left and right. Components free of all debris.
Lights/Switches	Check headlight HI/LO beam - light switch to OFF. Check taillight/brakelight - light switch to OFF. Check drive select switch - set to 2WD.
Air Filter	Duck bill drains clear of all debris. Ducting secure - no holes or tears.
Tires/Wheels	Properly inflated - tread adequate. Check tires for cuts or tears. Wheels secure to hubs - hubs secure to axles. Check wheels for cracked or bent rims.
Seat Belts/Restraints	Check condition - proper operation - proper adjustment.
Nuts/Bolts/Fasteners	Check for loose nuts - bolts - tighten as necessary. Check fasteners - latches - ROPS. Secure hood, cargo box, seats.

Starting the Vehicle

Always start with the vehicle on a flat, level surface. Carbon monoxide poisoning can kill you, so keep the vehicle outside while it's running. Follow these steps to start it up:

1. Step into the vehicle and sit down; then fasten the operator seat belt and the passenger seat belts (if applicable) and strap on your approved helmet and require your passengers to do the same (if applicable). Check that the occupant side restraints are secured in place.

WARNING

Falling from a moving vehicle could result in serious injury or death. Always fasten your seat belt securely and ensure the passenger seat belt is properly and securely fastened prior to operating or riding in this vehicle.

2. Shift into park.
3. Depress the brake pedal.
4. Turn the ignition switch clockwise to the START position; then when the engine starts, release to the RUN position. Do not increase engine RPM above idle.

CAUTION

Increasing engine RPM above idle while in Park will cause belt damage.

CAUTION

Do not run the starter motor for more than eight seconds per starting attempt. The starter motor may overheat causing severe starter motor damage. Allow 15 seconds between starting attempts to allow the starter motor to cool.

5. Let the engine warm up.

Shifting the Continuously Variable Transmission (CVT)

CAUTION

Always come to a complete stop before attempting to shift from one range to the other or into reverse or park. Always shift on level ground or apply the brakes.

■ NOTE: The CVT is fully automatic and shifts as a function of engine RPM and vehicle loading.

1. To select high range from park, move the shift lever upward through reverse and neutral until the letter "H" is displayed on the liquid crystal display (LCD).



TC038

2. To select low range from high range, move the shift lever upward one position until the letter "L" is displayed on the LCD.



TC039

■ NOTE: The high range is for normal driving with light loads. The low range is for carrying heavy loads or trailer towing. Compared to HIGH range, the LOW range position provides slower speed and greater torque to the wheels.

CAUTION

Always shift into low range when operating on wet or uneven terrain, when towing or pushing heavy loads, and when using a plow. Failure to follow this caution may result in premature V-belt failure or in damage to related drive system components.

3. To select reverse gear from park, move the shift lever upward one position until the letter "R" is displayed on the LCD.



TC040

4. To select neutral from park, move the shift lever upward two positions until the letter "N" is displayed on the LCD.



TC041

5. To select park, move the shift lever completely down until the letter "P" is displayed on the LCD gauge.



TC042

CAUTION

Never increase engine speed above idle RPM when in park or belt damage will occur.

Driving the Vehicle

Once the engine is warm, the vehicle is ready to be driven.

1. With the engine idling, press the foot brake pedal to apply the brake; then select the appropriate operating range and/or direction with the shift lever.
2. Release the foot brake pedal and press the accelerator to slowly add power to start moving.
3. To slow down or stop, release the accelerator and press the foot brake pedal as necessary to slow or stop the vehicle.

Braking/Stopping

Always allow plenty of room and time to stop smoothly. Sometimes quick stops are inevitable, so always be prepared. Whether you're stopping slowly or stopping quickly, do this:

1. Release the accelerator; then press the foot brake pedal to apply the brake.
2. If the wheels lock, release them for a second; then apply them again. On surfaces such as ice, mud, or loose gravel, pump the brake pedal rapidly.
3. Never "ride" the brake. Even maintaining minimal pressure on the brake pedal will cause the brake pads to drag on the disc and may overheat the brake fluid.

WARNING

Excessive repetitive use of the hydraulic brake for high speed stops will cause overheating of the brake fluid and premature brake pad wear which will result in an unexpected loss of brakes.

⚠ WARNING

Use only DOT 4 approved brake fluid. Never substitute or mix different types or grades of brake fluid. Brake loss can result. Check brake fluid level and pad wear before each use. Brake loss can result in serious injury or death.

Parking

Parking involves following the previous rules for braking; then:

1. After the vehicle stops, shift into park.
2. Then turn off the ignition.

⚠ WARNING

Avoid parking this vehicle on hills. The shift lever could inadvertently be moved from park and allow the vehicle to roll downhill causing personal injury or property damage.

3. If you have to park on a hill, shift to park and block the wheels on the downhill side.

Basic Turns

Steering effort is at its lowest in two-wheel drive (2WD). Greater effort is needed when in four-wheel drive (4WD). The greatest effort is needed when in four-wheel drive and the differential (700 only) is locked. Never exceed 16 kph (10 mph) in the LOCK position.

Slow down before entering a turn. The basic turning technique is to drive at low speed and gradually adjust the amount of steering to suit the driving surface. Do not make sudden sharp turns on any surface. Refer to the sub-sections Driving Uphill, Driving Downhill, Crossing Obstacles, Driving in Reverse, Skidding or Sliding, Crossing Water, or Crossing Roads for more information.

If your vehicle ever skids sideways during a turn, steer in the direction of the skid. Also, avoid hard braking or accelerating until you have regained directional control.

⚠ WARNING

Use care in turns - turning the steering wheel too far or too fast can result in loss of control or a rollover. Excessive speed, driving aggressively, or making abrupt maneuvers, even on flat, open areas, can cause loss of control, tipping, or rollover. Uneven terrain, rough terrain, soft surfaces, slippery surfaces, and paved surfaces can also cause a loss of control or rollover in a turn. On loose or soft surfaces, allow yourself more time and distance to turn and slow down.

Driving Uphill

Always drive straight up the hill and always avoid hills steeper than 15°.

1. Keep both hands on the wheel.
2. Prior to starting the climb, shift into low range, select four-wheel drive for traction, and gradually press the accelerator; then maintain a constant speed.

⚠ WARNING

Do not attempt to turn around on a hill.

⚠ WARNING

Driving up hills improperly can cause loss of control of the vehicle resulting in serious injury or even death. Use extreme care when driving in hilly terrain.

3. If the vehicle stalls on a hill, press the foot brake pedal to apply the brake, shift into reverse, and slowly back down the hill. Do not attempt to turn around on a hill.

NEVER OPERATE UP OR DOWN HILLS STEEPER THAN 15°



Driving Downhill

Always drive straight down the hill and always avoid hills steeper than 15°.

1. Keep both hands on the wheel.

2. Prior to descending the hill, shift into low range and release the accelerator to allow maximum engine braking. Do not use four-wheel drive when descending a hill. Engine braking can cause the front wheels to slide reducing steering control.

■ **NOTE: Use minimum braking (as necessary) to maintain a slow speed.**

⚠ WARNING
Do not attempt to turn around on a hill.

⚠ WARNING
Driving down hills improperly can cause loss of control of the vehicle resulting in serious injury or death. Never drive downhill at a high rate of speed. Use extreme care when driving in hilly terrain.

Crossing Obstacles

Crossing obstacles can be hazardous. There is always the possibility of the vehicle tipping. If you cannot go around an obstacle, follow these guidelines:

1. Stop the vehicle and shift into park. Go out to inspect the obstacle thoroughly from both your approach side and the exit side. If you believe you can cross the obstacle safely, select four-wheel drive (4WD).

■ **NOTE: Selecting the LOCK position on the differential lock control may be beneficial; however, steering effort will be greatly increased.**

2. Approach the obstacle as close as possible to 90° to minimize vehicle tipping.
3. Keep speed slow enough to maintain control but fast enough to maintain momentum.
4. Use only enough power to cross the obstacle but still give yourself plenty of time to react to changes in conditions. Crawl over the obstacle.

⚠ WARNING
Striking hidden obstacles can cause serious injury or death. Reduce speed and proceed with care in unfamiliar terrain.

■ **NOTE: If there is any question about your ability to cross the obstacle safely, you should turn around if the ground is flat and you have room or back up until you find a less difficult path.**

Driving in Reverse

When operating in reverse, avoid sharp turns and backing down a hill. When using reverse, follow these guidelines:

1. Back up slowly. It's hard to see behind you.

■ **NOTE: Avoid sudden braking while backing up.**

2. If possible, it is advisable to have someone "spotting" for you while backing up.
3. If you are unsure of what is behind the vehicle, place the transmission in park and get out and inspect the area behind.

Skidding or Sliding

If you lose control after hitting sand, ice, mud, or water, follow these guidelines:

1. Turn the steering wheel into the direction of the slide.
2. Keep your foot off the brake until you're out of the skid.
3. Stop and shift into four-wheel drive.

Crossing Water

This vehicle can only operate in water up to its floorboard. Stay away from fast moving rivers. This vehicle's tires can be buoyant. In deep water, the vehicle may lose traction due to floating.

1. Physically check the depth and current of the water, especially if you can't see the bottom. Also, check for boulders, logs, or any other hidden obstacles.
2. Keep speed slow while maintaining momentum.
3. Make sure you have a way out on the other side of the water.
4. Once you've cleared the water, briefly apply the brakes to make sure they work.

■ **NOTE:** Light pedal pressure or pumping the brakes for a short distance will aid in drying the brakes.

Crossing Roads

It may be necessary to cross a road or highway. If so, note the following guidelines.

1. Stop completely on the shoulder of the road.
2. Check both directions for traffic.
3. Crossing near a blind corner or intersection is dangerous; avoid it if at all possible.
4. Drive straight across to the opposite shoulder.
5. Take into account that this vehicle could stall while crossing; give yourself enough time to get off the road.
6. You have to assume that oncoming cars don't see you, and if they do, they won't be able to predict your actions.
7. It's illegal to cross public roads in some places. Know your local laws.

Cold Weather Driving

■ **NOTE:** Check that all control levers and the pedals move freely. Make sure that the floorboard is free of ice and snow.

WARNING

For your personal safety, it is very important to wear the type and amount of cold-weather clothing according to the coldest anticipated temperatures.

1. With the transmission in neutral, move the vehicle forward and backward to check that the wheels roll freely. If the vehicle will not roll, the tires may be frozen to the ground or the brake pads may be frozen to the discs.

2. If the tires are frozen to the ground, pour warm water around them to melt the ice.

CAUTION

Before riding, manually move the vehicle forward and backward to make certain that all wheels roll freely.

3. If the brakes are frozen, use a suitable heating device to thaw out the brakes.

WARNING

Do not attempt to free frozen brakes by pouring warm water on the brake pads and housings.

■ **NOTE:** After the brakes thaw, dry them by applying them several times while riding slowly.

■ **NOTE:** After riding through water, mud, snow, or slush, it is important to dry the brakes before parking the vehicle.

WARNING

Go slowly and be extra careful when riding on snow-covered or ice-covered terrain. Always be alert to changing terrain conditions when operating the vehicle.

WARNING

Do not operate this vehicle on a frozen body of water. The vehicle could break through the ice causing serious injury or death.

4. Practice driving in an open snow-covered or ice-covered area at slow speeds before driving on snow-covered or ice-covered trails.
5. Learn how the vehicle responds to steering and braking on the type of terrain to be encountered on the ride.

General Information

Control Locations and Functions

Ignition Switch Key

Two keys come with this vehicle. Keep the spare key in a safe place.

Ignition Switch

The ignition switch has three positions.

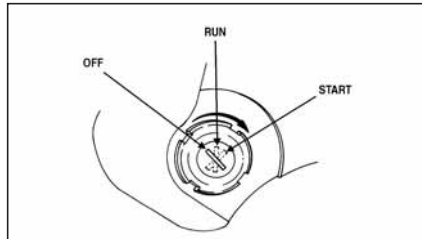

ATV-0056A

OFF position — All electrical circuits except the accessory are off. The engine will not start. The key can be removed in this position.

■ **NOTE: The accessory plugs are powered by the battery at all times.**

RUN position — The ignition circuit is complete and the engine can run. The key cannot be removed in this position.

START position — The ignition circuit is complete and the starter is engaged. When the key is released, the switch will return to the RUN position. The key cannot be removed in this position.

■ **NOTE: This vehicle has safety interlock switches which prevent the starter motor from activating when the transmission is not in neutral. Depress and hold the brake pedal to engage starter when the transmission is not in neutral.**

Shift Lever

This vehicle is equipped with a constant velocity transmission (CVT) coupled to a dual-range transmission with reverse and park.



TC037

Drive Select Switch



TC023A



HDX108C

This switch allows the operator to operate the vehicle in either two-wheel drive (rear wheels) or four-wheel drive (all wheels) as well as mechanically lock the differential (700 only) to apply equal power to both front wheels. For normal riding on flat, dry, hard surfaces, two-wheel drive should be sufficient. In situations when additional traction is necessary, four-wheel drive would be the desired choice.

To select 2WD, depress the bottom of the switch. To select 4WD, move the switch to the middle position. To engage the differential lock, slide the switch latch slightly downward while pressing the top of the switch forward.

CAUTION

Do not attempt to either engage or disengage the front differential while the vehicle is moving.

■ **NOTE:** On the 700 only when the differential lock is engaged, the indicator light will be illuminated.

WARNING

The differential lock is intended for use where minimum traction is available. **NEVER EXCEED 16 kph (10 MPH)** with the front differential lock engaged. Maneuverability and handling characteristics will differ with the differential lock engaged. Control loss can result in serious injury or death.

Foot Brake

The foot brake is the only service brake, and it should be applied whenever braking is needed.

Apply the brake by pressing the brake pedal down.

Headlight Switch



HDX108A

Use the headlight switch to select the high or low headlight beam. When the switch is in the HI position, the high beam will illuminate. When the switch is in the LO position, the low beam will illuminate.

Reverse Override Switch

This vehicle is equipped with a reverse speed limiter system. When additional RPM is needed in reverse, depress and hold the override switch located on the dash.



HDX108B

■ **NOTE:** The vehicle must be in 4WD to activate the reverse override.

WARNING

Never activate the override switch while the throttle is open as a loss of control could result.

Accelerator Pedal

Press down on the pedal to increase engine RPM and vehicle speed; release the pedal to decrease engine RPM and vehicle speed.

■ **NOTE:** This vehicle is equipped with an RPM limiter that retards ignition timing when maximum RPM is approached. When the RPM limiter is activated, it could be misinterpreted as a high-speed misfire.

Seat

1. To remove the seat, lift up on the front of the seat; then slide it forward.
2. To lock the seat into position, slide the rear of the seat into the seat retainers and push down firmly on the front of seat. The seat must engage the retainers and lock into position.

WARNING

Make sure the seat is secure before driving the vehicle. Serious injury or death could result if the seat is not properly secured.

■ **NOTE:** To remove the seat base and seat back, first remove the four screws securing the seat back and set the seat back aside. Remove the screws securing the seat base and set the seat base aside.

Seat Belts

This vehicle is equipped with seat belts for the operator and two passengers. To fasten and release the seat belt properly, use the following procedure.

1. Place the seat belt across your lap as low as possible without twisting the belt making sure the shoulder strap is below the neck and across the chest.

WARNING

Only appropriate-sized passengers may ride in this vehicle. Passengers must be able to place both feet flat on the floor while keeping their back against the back of the seat and holding on to available hand holds.

2. Push the latch-plate into the buckle slot until it “clicks” and latches securely. The belt will retract when the buckle is released.

WARNING

Falling outside a moving vehicle could result in serious injury or death. Always fasten your seat belt securely and ensure the passenger seat belt is properly and securely fastened prior to operating or riding in this vehicle.

Occupant Side Restraints

In addition to the seat belts, there are left- and right-side restraints to restrict arms or legs from extending outside the vehicle. The restraints should always be secured when the vehicle is moving.

To secure the restraint, connect the restraint buckle to the foot restraint latch bracket. To release the restraint, press the release button in the center of the buckle.



HDX187A



HDX188

Cargo Box

The cargo box on this ROV can be converted to a “flat-bed” cargo platform. To convert your cargo box to a flat-bed, use the following procedure.

1. Remove all cargo from the box; then remove the left and right forward tie bolts.



TC006

2. Raise the cargo box; then loosen the four retaining bolts securing the side panels in the stake pockets; then lower the box.

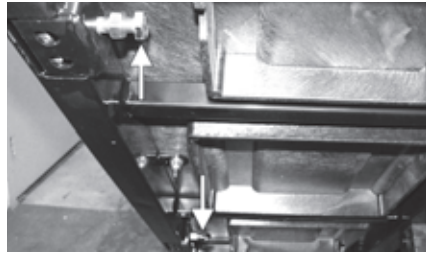

HDX112A

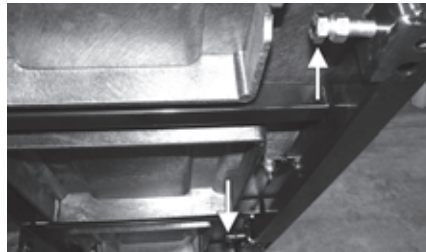

HDX113A

3. Open the tailgate and remove the machine screws securing the stop-cables to the tailgate. Note the correct orientation of the bushings to the cable ends and tailgate.



HDX114A

4. Lift off the left and right cargo box panels; then remove the tailgate from the cargo bed.



HDX117

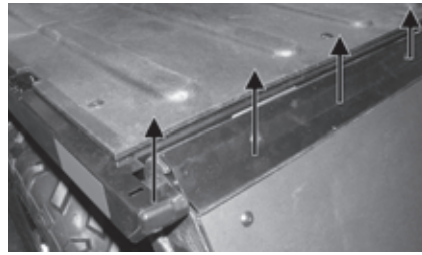

HDX115A

5. Remove the stake pocket retaining bolts, jam nuts, and forward tie bolt clip nuts and secure in a safe place with the machine screws and bushings from the tailgate.

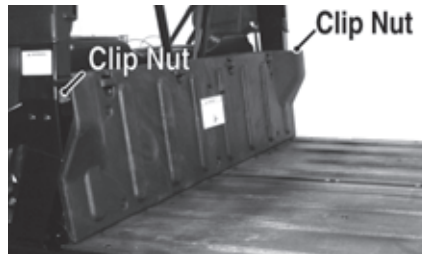

HDX116A

To convert flat-bed to cargo box, use the following procedure.

1. Set the tailgate into position in the cargo bed; then lift the cargo bed making sure the tailgate clears any receiver hitch attachments.

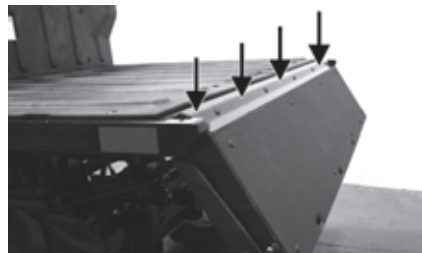

HDX117A

2. Install the stake pocket retaining bolts and jam nuts leaving clearance to install side panel stakes.

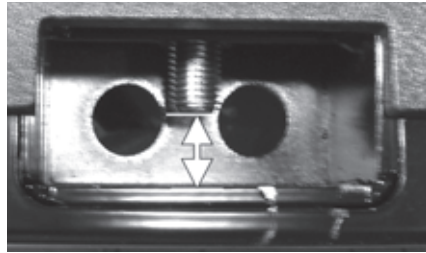

HDX118A

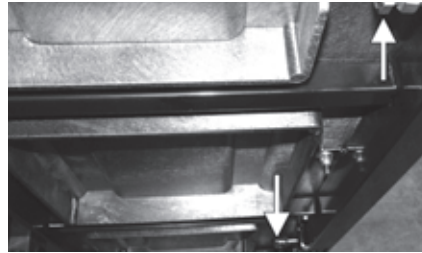

HDX113A

3. Set the left and right cargo box side panels into place on the cargo bed engaging the stakes into the side pockets.
4. Install the left and right side clip nuts onto the frame; then install and tighten the forward tie bolts securely.



HDX116A



HDX122

6. Secure the tailgate stop-cables to the tailgate with the machine screws and bushings making sure the bushing engages the cable as shown. Tighten to 2.7 N-m (24 in.-lb).

5. Tighten the four stake pocket retaining bolts to 34 N-m (25 ft-lb) making sure the cargo box side panels are resting firmly on the cargo bed; then tighten the jam-nuts to 20 N-m (15 ft-lb). Lower the cargo box.



HDX112A



HDX123

Cargo Box Tie Downs

The cargo box has numerous tie down locations around the top perimeter. Always secure cargo with tie down straps to avoid shifting or damage to cargo.

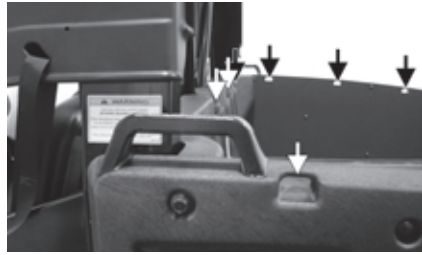

HDX094A

CAUTION

When using ratchet-type straps, do not over tighten or damage to the cargo box could occur.

■ **NOTE:** Always refer to the Load Capacity Ratings chart in this manual when loading and hauling cargo.

Tailgate Latches



TC010

1. To open the tailgate, pull the latch handles (located on the end of the tailgate).
2. To close the tailgate, lift up and push forward firmly. Hook the latch bails and push the handles forward over center.



TC009

Cargo Box Latch Handles



TC008A

1. To raise the cargo box, lift the latch handle upward; then raise the cargo box.



HDX094

2. To lower the cargo box, use the box handle to push down firmly on the front of the box. The box will automatically lock into position and an audible “click” will be heard.

Speedometer/LCD



TC015

1. Speedometer/Tachometer/Condition Warning Display - Indicates the approximate vehicle speed (MPH or km/h) or RPM. Warns of a system error condition requiring attention.

The LCD will go blank except the word VOLT will flash on the LCD whenever a low voltage (<9 DC volts) or a high voltage (>16 DC volts) is detected. When voltage returns to normal, the gauge must be reset by turning the ignition key to the OFF position and then to the ON position.

A diagnostic trouble code (DTC) will flash on the LCD whenever an electronic fuel injection (EFI) system error is detected. After 30 seconds, the gauge will return to normal, but the code will continue to flash until the malfunction is corrected.

■ **NOTE: Take the ROV to an authorized Toro ROV dealer to have the error corrected and the system error reset as soon as possible.**

2. Fuel Level Indicator - Indicates approximate amount of gasoline in the gas tank.

■ **NOTE: When the bottom segment flashes, approximately 3.5 L (0.92 U.S. gal.) of gasoline remains in the tank.**

3. Mode Button - Press and release to shift the gauge between MPH or km/h and RPM. Press and hold to switch between MPH and km/h.
4. Set/Reset Button - Press and release to shift between Odometer, Trip 1, Trip 2, Engine Hour Meter, and Clock. Press and hold while Trip 1 or Trip 2 are selected to clear the selected trip. The odometer cannot be reset.
5. Odometer/Trip Meter/Clock/Engine Hour Meter - Displays odometer (total distance the vehicle has traveled) or one of two trip meters used to measure trips or trip legs corresponding to the function selected (MPH or km/h). The clock function indicates time in the 12 hour mode. The hour meter indicates the total time the ROV has run and cannot be reset to zero. To set the clock, use the following procedure.

- A. With the ignition switch ON, press and release the Mode Button until the Clock/Engine Hour Meter is displayed; then (if necessary) press and release the Set/Reset Button to the clock display.
- B. Press and hold Set/Reset Button until minutes stop scrolling and the hour display starts to scroll. Momentarily release when correct hour is displayed; then repeatedly press and release Set/Reset Button until correct minutes are displayed.

■ **NOTE: Approximately two seconds after releasing either Button, the LCD will return to normal operation.**

■ **NOTE: Clock memory power is supplied through the 15-amp accessory fuse and verified during gauge “power-up” and reset. In the event of clock memory power failure (blown fuse, etc.), the gauge will “power-up,” reset, and shut down repeatedly until clock memory power is restored. Always check the 15-amp accessory fuse if this gauge condition is noted.**

■ **NOTE: The engine hour meter will not activate until engine speed exceeds 500 RPM.**

6. Gear Position Indicator - Indicates which gear is selected - R (reverse)/N (neutral)/H (high range)/L (low range)/P (park).

■ **NOTE: An E will be displayed if there is an error caused by a no-shift position signal.**

7. Engine Hour Meter Indicator - Indicates engine hour meter mode is selected on the display.
8. Speedometer/Tachometer Indicator - Indicates which mode (MPH, km/h, or RPM) is being displayed.
9. 4WD Lock Indicator (700 only) - Displays LOCK when the front differential lock has been engaged.
10. Drive Select Indicator - Displays 4WD when selected by the drive select switch or when the 4WD lock is engaged. The display is blank when in 2WD.

11. High Beam Indicator - Appears when the headlights are on high beam.
12. Temperature Indicator - The speedometer/tachometer needle will sweep full scale and the LCD will go blank except the high temperature icon will flash. After 30 seconds, the speedometer/tachometer needle and LCD will return to normal, but the temperature icon will continue to flash. The icon should not be visible during normal operation.
13. Odometer/Trip Meter Indicator Display - Displays which function (ODO, Trip, or Trip 2) is selected.
14. Wrench Indicator - Displayed in conjunction with a DTC whenever an EFI system error is detected.
15. Seat Belt Indicator - Displayed whenever the driver's seat belt is not fastened.



Electric Fuel Pump

An electric fuel pump is mounted in the gas tank to deliver gasoline to the fuel injector. The fuel pump operates when the ignition switch is turned to the ON or START position.

Gas Hoses

Replace the gas hose every two years. Damage from aging may not always be visible.

Oil Level Stick

There is an oil level stick for checking the engine oil level. To check the oil level, use the following procedure.

■ **NOTE: The vehicle should be on level ground when checking the engine oil level.**

1. Lift the cargo box.

2. From the left side, unscrew the oil level stick and wipe it with a clean cloth.

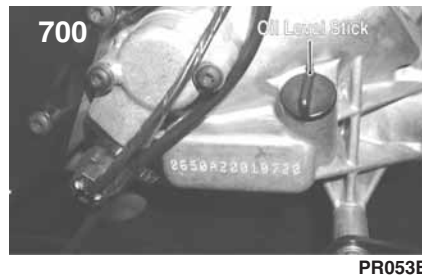
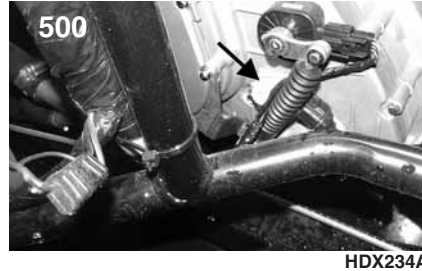

3. Install the oil level stick.

■ **NOTE: The oil level stick should be threaded in for checking purposes.**

4. Remove the oil level stick; the engine oil level must be within the operating range but not exceeding the upper mark.



GZ461A

5. On the 500, add oil to the oil level stick opening until proper operating level is achieved. On the 700 to add oil, remove the seat, oil fill cap access cover, and oil fill cap (using a 27 mm socket). After adding oil, install the fill cap and tighten to 16 ft-lb; then install the cover and seat.



HDX022A

CAUTION

Do not overfill the engine with oil. Always make sure the oil level is within operating range.

Load Capacity Ratings

This vehicle must always be loaded in accordance with the Load Capacity Ratings chart. Under no circumstances should the Vehicle Load Capacity or the Gross Vehicle Weight (GVW) rating ever be exceeded.

⚠ WARNING

Overloading this vehicle could result in loss of control resulting in serious injury or death.

Load Capacity Ratings		
Item	Specifications	
Vehicle Load Capacity (500)	1100 lb	498 kg
Vehicle Load Capacity (700)	1500 lb	680 kg
Tongue Weight	150 lb	68 kg
Rear Tongue and Cargo Weight (max) (500)	600 lb	272 kg
Rear Tongue and Cargo Weight (max) (700)	1000 lb	454 kg
Towing Capacity	1500 lb	680 kg

Vehicle Load Capacity - Total weight of operator, passenger(s), trailer tongue weight, accessories, and cargo.

Tongue Weight - Weight of trailer tongue on hitch.

Accessory Weight - Winch, gun scabbard brackets, etc.

Rear Tongue and Cargo Weight - Total weight of trailer tongue and cargo in the box.

Towing Capacity - Total weight of trailer and all cargo in the trailer.

Trailer and Towing

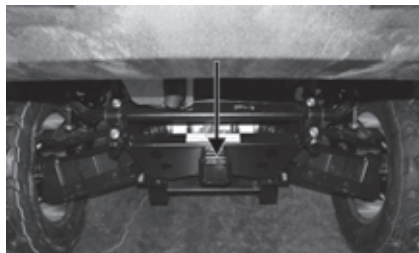

HDX062A

This vehicle is equipped with a frame-mounted receiver (front and rear) for a standard 5.1 cm (2 in.) receiver hitch. The standard receiver hitch must be purchased separately.

⚠ WARNING

Make sure that the load in the trailer is properly secured and will not shift while moving. Also, do not overload the trailer.

When loading a trailer properly, two items are critical: Gross Trailer Weight (the weight of the trailer plus cargo) and Trailer Tongue Weight.

⚠ WARNING

Never exceed any of the vehicle weight restrictions.

Trailer Tongue Weight is the downward force exerted on the hitch by the trailer coupler when the trailer is fully loaded and the coupler is at its normal towing height. Refer to the Load Capacity Ratings chart for tongue weight information.

Always maintain a slow speed when trailering and towing and avoid sudden accelerations, quick maneuvers, and sudden stops. Braking distance will be affected when towing a trailer. When towing a trailer, always maintain slow speed and allow more stopping distance than when not towing a trailer.

⚠ WARNING

Driving this vehicle without extra caution when towing a trailer will be hazardous. Trailer towing can affect the handling and braking of the vehicle. Tow only at low speeds and never exceed 16 kph (10 mph). Avoid sudden accelerations and stopping of the vehicle. Do not make quick maneuvers. Avoid uneven surfaces and do not tow on hills. Never carry passengers in a trailer unless the trailer is designed for such use and has a rigid tow bar. Allow more stopping distance than when not towing a trailer.

Transporting

■ **NOTE:** When transporting the vehicle, make sure the vehicle is in park.

Inform the owner/operator that this vehicle must be transported in its normal operating position (on all four wheels) and secured with hold-down straps in the proper areas. Shown is the minimum number of hold-down straps to be used.

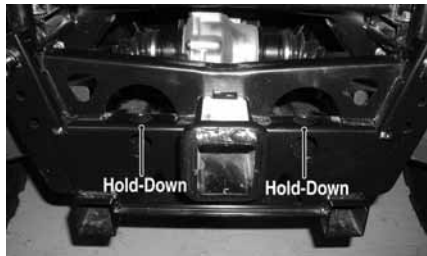

PR075A

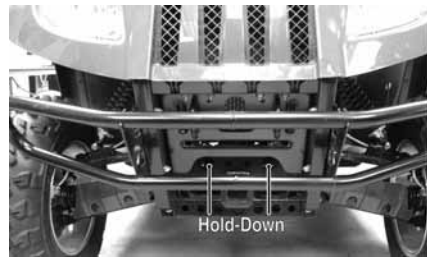

PR073A

CAUTION

If using additional hold-down straps in any other areas, care must be taken not to damage the vehicle.

⚠ WARNING

Use extreme caution when operating a machine on a ramp.

Ensure that the ROPS will clear the top of an enclosed trailer.

Use only a full-width ramp; do not use individual ramps for each side of the machine.

Do not exceed a 15-degree angle between the ramp and the ground or between the ramp and the trailer or truck.

Ensure the length of ramp is at least four times (4X) as long as the height of the trailer or truck bed to the ground. This will ensure that ramp angle does not exceed 15-degrees on flat ground.

Avoid sudden acceleration or deceleration while driving the machine on a ramp as this could cause a loss of control or a tip-over situation.

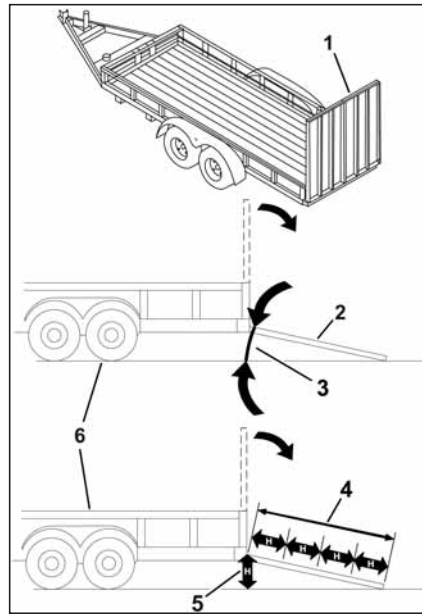

TC028

Gasoline-Oil-Lubricant Recommended Gasoline

The recommended gasoline to use in this vehicle is 87 minimum octane regular unleaded. In many areas, oxygenates are added to the gasoline. Oxygenated gasolines containing up to 10% ethanol or 5% methane are acceptable gasolines.

When using ethanol blended gasoline, it is not necessary to add a gasoline antifreeze since ethanol will prevent the accumulation of moisture in the fuel system.

CAUTION
Do not use white gas. Only recommended gasoline additives should be used.

Recommended Engine/Transmission Oil

CAUTION
Any oil used in place of the recommended oil could cause serious engine damage. Do not use oils which contain graphite or molybdenum additives. These oils can adversely affect clutch operation. Also, not recommended are racing, vegetable, non-detergent, and castor-based oils.

The recommended oil to use is Toro 0W-40 All Weather synthetic engine oil, which has been specifically formulated for use in this engine. Although Toro 0W-40 All Weather synthetic engine oil is the only oil recommended for use in this engine, use of any API certified SM 0W-40 synthetic oil is acceptable.

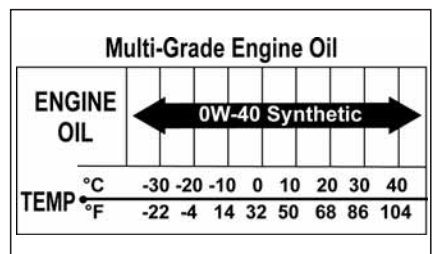

OILCHARTJ

■ **NOTE:** If the vehicle will be operated under severe conditions (heavy pulling or loading, extremely high ambient air temperatures, or extended high-speed operation), Toro recommends installing an engine oil cooler kit if not so equipped. For additional information, see your local authorized Toro ROV dealer.

Recommended Front Differential/Rear Drive Lubricant

■ **NOTE:** Toro recommends the use of genuine Toro lubricants.

The recommended front differential/rear drive lubricant is SAE approved 80W-90 hypoid. This lubricant meets all of the lubrication requirements of this vehicle.

CAUTION
Any lubricant used in place of the recommended lubricant could cause serious front differential/rear drive damage.

Filling Gas Tank

⚠ WARNING
Always fill the gas tank in a well-ventilated area. Never add gasoline to the gas tank near any open flames or with the engine running or hot. DO NOT SMOKE while filling the gas tank.

Since gasoline expands as its temperature increases, the gas tank must be filled to its rated capacity only. Expansion room must be maintained in the tank particularly if the tank is filled with cold gasoline and then moved to a warm area.

Allow the engine to cool before filling the gas tank. Care must be taken not to overfill the tank past the full mark. If overfilled, gas may leak out creating a fire hazard.



ROV353A

⚠ WARNING

Do not over-flow gasoline when filling the gas tank. A fire hazard could materialize. Always allow the engine to cool before filling the gas tank.

Tighten the gas tank cap securely after filling the tank.

⚠ WARNING

Do not overfill the gas tank.

Engine Break-In

After the completion of the break-in period, the engine oil and oil filter should be changed. Other maintenance after break-in should include checking of all prescribed adjustments and tightening of all fasteners. At the discretion and expense of the owner/operator, the vehicle may be taken to an authorized Toro ROV dealer for this initial service.

New vehicles and engines require a “break-in” period. The first month is most critical to the life of this vehicle. Proper operation during this break-in period will help assure maximum life and performance from this vehicle.

During the first 10 hours of operation, always use less than ½ throttle. Varying the engine RPM during the break-in period allows the components to “load” (aiding the engine/transmission component mating process) and then “unload” (allowing components to cool). Although it is essential to place some stress on the engine components during break-in, care should be taken not to overload the engine too often. Do not pull a trailer during the break-in period.

When the engine starts, allow it to warm up properly. Idle the engine several minutes until the engine has reached normal operating temperature. Do not idle the engine for excessively long periods of time.

Burnishing Brake Pads

Brake pads must be burnished to achieve full braking effectiveness. Braking distance will be extended until brake pads are properly burnished.

⚠ WARNING

Do not attempt sudden stops or put yourself into a situation where a sudden stop will be required until the brake pads are properly burnished.

1. Choose an area sufficiently large to safely accelerate to 50 km/h (30 mph) and to brake to a stop.
2. Accelerate to 50 km/h (30 mph); then press brake pedal to decelerate to 0-8 km/h (0-5 mph).
3. Repeat procedure twenty times.

General Maintenance

■ **NOTE:** Proper maintenance of the ROV is important for optimum performance. Follow the Maintenance Schedule and all ensuing maintenance and care instructions/information.

■ **NOTE:** Proper maintenance procedures for each item can be found on the corresponding page indicated.

If, at any time, abnormal noises, vibrations, or improper functioning of any component of this vehicle is detected, **DO NOT OPERATE THE VEHICLE.** Take the vehicle to an authorized Toro ROV dealer for inspection and adjustment or repair.

If the owner/operator does not feel qualified to perform any of these maintenance procedures or checks, take the vehicle to an authorized Toro ROV dealer for professional service.

Maintenance Schedule					
Item	Page	Initial 160 km (100 miles)	Every 160 km (100 miles)	Every 480 km (300 miles)	Every 800 km (500 miles)
Battery	43	I	I		
* Engine nuts and bolts	—	I			I
* Valve clearance	—	I			I
Spark plug	45	I			I
	45	Replace every 6500 km (4000 miles) or 18 months			
Liquid cooling system	38	I	Inspect every time before operating		
Gas hoses	31	I	Inspect every time before operating		
	31	Replace every 2 years			
Engine/transmission oil and filter	39	R		R**	
Air filter	46	I		I	
Gear lubricant (front differential - rear drive)	40	R			I
	40	Replace every 2 years or 3200 km (2000 miles)			
V-Belt	47	I			I
Spark arrester/muffler	48				C
Tires/air pressure	47/17	I	Inspect every time before operating		
* Brake components	41	I	Inspect every time before operating		
Brake fluid	41	I	*Replace every 2 years		
Brake hoses	41	I	*Replace every 4 years		
* Steering	—	I	Inspect every time before operating		
* Suspension (Ball joint boots, drive axle boots front and rear, tie rods, differential and rear drive bellows)	—	I	Inspect every time before operating		
* Chassis nuts and bolts	—	I	T		
Wheel lug nuts	48	T		T	
Frame/welds/racks	—	I			I
Electrical connections	—	I			I
Headlight/taillight-brakelight	49	I	Inspect every time before operating		
Air filter drains	—	I	Inspect every time before operating		
Accelerator pedal	25	I	Inspect every time before operating		
ROPS	51		Inspect every time before operating		
Occupant side restraints	51		Inspect every time before operating		
Wheel nuts	48	I	I		

I = Inspect and clean, adjust, lubricate, replace as necessary

T = Tighten R = Replace C = Clean

* = Dealer maintenance

**When using Toro 0W-40 All Weather synthetic oil, oil change interval can be increased to every 1600 km (1,000) miles or every year.

Liquid Cooling System

■ **NOTE:** Debris in the engine compartment or packed between the cooling fins of the radiator can reduce cooling capability. Using a garden hose, wash the radiator to remove any debris preventing air flow.

CAUTION

Do not use a pressure washer to clean the radiator core. The pressure may bend or flatten the fins causing restricted air flow, and electrical components on the radiator could be damaged. Use only a garden hose with spray nozzle at normal tap pressure.

The cooling system capacity can be found in the specification charts. The cooling system should be inspected daily for leakage and damage. If leakage or damage is detected, take the vehicle to an authorized Toro ROV dealer for service. Also, the coolant level should be checked periodically.

■ **NOTE:** High engine RPM, low vehicle speed, or heavy load can raise engine temperature. Decreasing engine RPM, reducing load, and selecting an appropriate transmission gear can lower the temperature.

CAUTION

Continued operation of the vehicle with high engine temperature may result in premature wear or engine damage.

When filling the cooling system, use a coolant/water mixture which will satisfy the coldest anticipated weather conditions of the area in accordance with the coolant manufacturer's recommendations.

■ **NOTE:** Use a good quality, biodegradable glycol-based, automotive-type antifreeze.

While the cooling system is being filled, air pockets may develop; therefore, remove the bleed plug on the coolant pipe at the front of the engine allowing trapped air to escape.

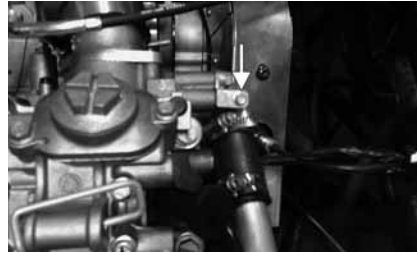

TC024A

When pure coolant (no air) flows from the bleed hole, install the bleed plug, tighten securely, and then fill the cooling system to the bottom of the stand pipe in the radiator neck. After operating the vehicle for the initial 5-10 minutes, stop the engine, allow the engine to cool down, and check the coolant level. Add coolant as necessary.

⚠ WARNING

Never check the coolant level when the engine is hot or the cooling system is under pressure.

Shock Absorbers

Each shock absorber should be visibly checked weekly for excessive fluid leakage (some seal leakage may be observed but it does not indicate the shock is in need of replacement), cracks or breaks in the lower case, or a bent shock rod. If any one of these conditions is detected, replacement is necessary.

■ **NOTE:** When the vehicle is operated in extremely cold weather (-23°C/-10°F or colder), a small amount of leakage may be present. Unless the leakage is excessive, replacement is not necessary.

This vehicle is equipped with adjustable shock absorbers in the front and rear to allow for different driving and loading conditions.

The front shock absorbers (700) or front and rear shock absorbers (500) have an adjustment sleeve with five preload adjustment positions that can be turned with a special spanner wrench to increase or decrease coil spring tension.

To adjust the spring force on the these shock absorbers, rotate the pre-load adjustment sleeve with a suitable spanner wrench until desired spring tension is achieved.

Position	Spring Force	Setting	Load	
1	↓ Stronger	Soft	Light	
2		↑	↑	
3		↕	↕	
4		↓	↓	↓
5		Stiff	Heavy	



PR015

On the 700, the rear shock absorber has a spring force adjustment nut with an infinite adjustment from softest to most firm. If the spring action is too soft or too stiff, adjust the nut using an appropriate spanner as illustrated.

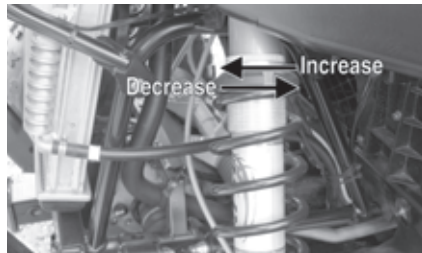

HDX085A

■ **NOTE:** Before attempting to adjust suspension, clean dirt and debris from the sleeve and remove load from the suspension; then use the spanner wrench to adjust the sleeve to the desired position.

General Lubrication

Cables

None of the cables require lubrication; however, it is advisable to lubricate the ends of the cables periodically with a good cable lubricant.

Cargo Box Latches

Periodically apply a light coat of grease to the latches and pins. Do not over grease.

Engine/Transmission Oil and Filter

■ **NOTE:** Refer to the recommended oil viscosity chart (on page 34) in this manual for the proper engine oil.

Change the engine oil and oil filter at the scheduled intervals. The engine should always be warm when the oil is changed so the oil will drain easily and completely.

1. Park the vehicle on level ground.
2. Remove the seat; then remove the backrest and seat base.
3. Loosen the oil fill cap using a 27 mm socket (700) or oil level stick (500). Be careful not to allow contaminants to enter the opening.

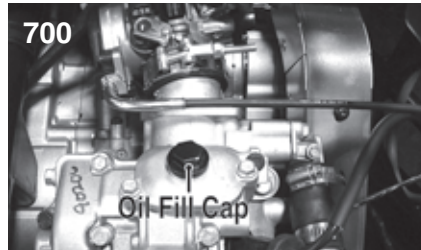

HDX042A



HDX234A

- Remove the drain plug from the bottom of the engine and drain the oil into a drain pan.

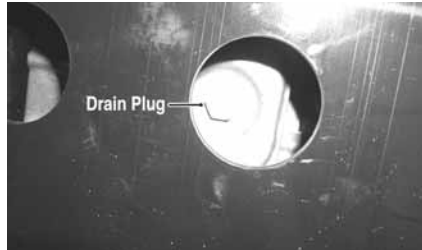

PR078A

- Use an appropriate oil filter wrench to remove the old oil filter and dispose of properly. Do not re-use oil filter.

■ **NOTE:** To access the filter, remove the seat, seat back, and seat base (see Seats in General Information).

■ **NOTE:** Clean up any excess oil after removing the filter.

- Apply oil to the new filter O-ring and check to make sure it is positioned correctly; then install the new oil filter. Tighten 3/4 turn after contact with the sealing flange.



TC031

- Install the engine drain plug and tighten to 22 N-m (16 ft-lb). Pour the recommended oil in the fill hole (700) or oil level stick opening (500). Install the oil fill cap (700) or the oil level stick (500).

- Start the engine (while the vehicle is outside on level ground) and allow it to idle for a few minutes.

- Turn the engine off and wait approximately one minute. Check the oil level (see Oil Level Stick on page 31).

- Inspect the area around the drain plug and oil filter for leaks.

- Install the seat base, seat, and backrest.

Front Differential And Rear Drive Gear Lubricant (Inspecting/Changing)

Inspect and change the gear lubricant in each according to the Maintenance Schedule. When changing the lubricant, use the following procedure.

- Place the vehicle on level ground.
- Remove the front differential and rear drive fill plugs.



HDX083A

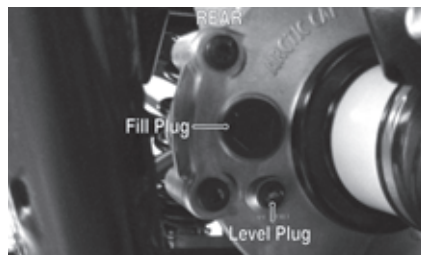

HDX084A

3. Drain the lubricant into a drain pan by removing the drain plug from the front differential and rear drive.



CF107A



CF106A

4. After all the lubricant has been drained, install the drain plugs and tighten to 5 N-m (45 in.-lb).

CAUTION

Inspect the oil for any signs of metal filings or water. If found, take the vehicle to an authorized Toro ROV dealer for servicing.

5. Pour SAE approved 80W-90 hypoid lubricant into each fill hole until it flows out of the hole.
6. Install the fill plugs and tighten to 22 N-m (16 ft-lb).

Hydraulic Brake

⚠ WARNING

Be sure to inspect the hydraulic brake system before each use. Always maintain brakes according to the Maintenance Schedule.

Brake Fluid

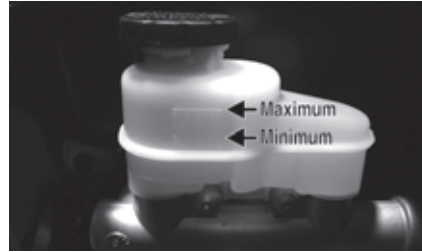

HDX081A

1. Check the brake fluid level in the brake fluid reservoir. The fluid level must be maintained between the MAX and MIN level marks. If the level in the reservoir is low, add DOT 4 approved brake fluid.

■ **NOTE: The brake fluid reservoir is located on top of the master cylinder under the hood.**

2. Press the brake pedal several times to check for firmness.
3. If the pedal is not firm, the system must be bled.

■ **NOTE: Take the vehicle to an authorized Toro ROV dealer for this service.**

CAUTION

Be careful not to spill any fluid when filling the brake fluid reservoir. Wipe away spilled fluid immediately.

Brake Hoses

Carefully inspect the hydraulic brake hoses for cracks or other damage. If found, take the vehicle to an authorized Toro ROV dealer to have the brake hoses replaced.

Brake Pads

The clearance between the brake pads and brake discs is adjusted automatically as the brake pads wear. The only maintenance that is required is replacement of the brake pads when they show excessive wear. Check the thickness of each of the brake pads as follows:

1. Remove a front wheel.
2. Measure the thickness of each brake pad.

- If thickness of either brake pad is less than 1.0 mm (0.039 in.), take the vehicle to an authorized Toro ROV dealer to have brake pads replaced.

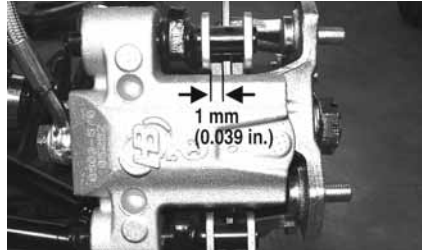

PR376B

- Install the wheel; then using a criss-cross pattern, tighten the wheel nuts in 27 N-m (20 ft-lb) increments to the final torque shown in the table below.

Steel Wheel	54 N-m (40 ft-lb)
Aluminum Wheel (Black Nuts)	80 N-m (60 ft-lb)
Aluminum Wheel (Chrome Nuts)	108 N-m (80 ft-lb)



PR941A

CAUTION

Using an impact wrench could result in incorrect torque which could damage the wheel or hub studs.

Protective Rubber Boots

The protective boots should be inspected before each use.

Ball Joint Boots (Upper and Lower/Right and Left)



CC791

- Secure the vehicle on a support stand to elevate the front wheels.
- Remove both front wheels.
- Inspect the four ball joint boots for cracks, tears, or perforations.
- Check the ball joint for free-play by grasping the steering knuckle and turning it from side to side and up and down.
- If boot damage is present or ball joint free-play seems excessive, contact an authorized Toro ROV dealer for service.

Tie Rod Boots (Inner and Outer/Right and Left)



CC792

- Secure the vehicle on a support stand to elevate the front wheels.
- Remove both front wheels.
- Inspect the four tie rod boots for cracks, tears, or perforations.
- Check the tie rod end free-play by grasping the tie rod near the end and attempting to move it up and down.
- If boot damage is present or tie rod end free-play seems excessive, contact an authorized Toro ROV dealer for service.

Drive Axle Boots



CC793

1. Inspect the front and rear drive axle boots for cracks, tears, or perforations.
2. If boot damage is present, contact an authorized Toro ROV dealer for service.

Battery

■ **NOTE:** Refer to all warnings and cautions provided with the battery or battery charger.

This ROV is shipped with a sealed battery. The battery requires an initial charge after activation as well as periodic maintenance-charging during periods of non-use or storage.

■ **NOTE:** Maintenance charging is required on all batteries not used for more than two weeks or as required by battery drain.

■ **NOTE:** The battery box is under the seat on the operator's side. To access the box, remove the seat and pry off the battery compartment cover; then remove the thumb screw securing the battery box cover and lift the cover to access the battery.

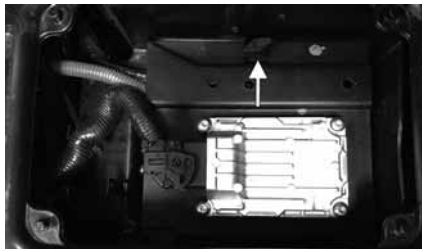

PR943A

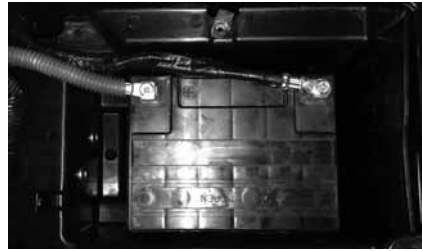

PR942

After being in service, batteries require regular cleaning and recharging in order to deliver peak performance and maximum service life. The following procedure is recommended for cleaning and maintaining a sealed battery. Always read and follow instructions provided with battery chargers and battery products.

■ **NOTE:** Refer to all warnings and cautions provided with the battery or battery maintainer/charger.

Loss of battery charge may be caused by ambient temperature, ignition OFF current draw, corroded terminals, self discharge, frequent start/stops, and short engine run times. Frequent winch usage, snowplowing, extended low RPM operation, short trips, and high amperage accessory usage are also reasons for battery discharge.

Charging/Maintenance Charging

⚠ WARNING

Any time service is performed on a battery, the following must be observed: keep sparks, open flame, cigarettes, or any other flame away. Always wear safety glasses. Protect skin and clothing when handling a battery. When servicing battery in enclosed space, keep the area well-ventilated. Make sure battery venting is not obstructed.

■ **NOTE:** When charging a battery in the vehicle, be sure the ignition switch is in the OFF position.

1. Clean the battery terminals with a solution of baking soda and water.

■ **NOTE: The sealing strip should NOT be removed and NO fluid should be added.**

2. Be sure the charger and battery are in a well-ventilated area. Be sure the charger is unplugged from the 110-volt electrical outlet.
3. Connect the red terminal lead from the charger to the positive terminal of the battery; then connect the black terminal lead of the charger to the negative terminal of the battery.
4. Plug the battery charger into a 110-volt electrical outlet.
5. Trickle charge the battery at 3 amps for 5-10 hours. If the battery becomes hot to the touch, stop charging. Resume after it has cooled.
6. Once the battery has reached full charge, unplug the charger from the 110-volt electrical outlet.

■ **NOTE: If, after charging, the battery does not perform to operator expectations, bring the battery to an authorized Toro ROV dealer for further troubleshooting.**

Jump-Starting

■ **NOTE: Do not jump-start a vehicle with a dead battery; rather remove the battery, service it, and correctly charge it. In an emergency, it may be necessary to jump-start a vehicle. If so, use the following procedure to carefully and safely complete this procedure.**

WARNING

Improper handling or connecting of a battery may result in serious injury including acid burns, electrical burns, or blindness as a result of an explosion. Always remove rings and watches.

1. On the vehicle to be jump-started, remove the battery cover and any terminal boots.

2. Inspect the battery for any signs of electrolyte leaks, loose terminals, or bulging sides. Leaking or bulging battery cases may indicate a frozen or shorted battery.

WARNING

If any of these conditions exist, DO NOT attempt a jump-start, boost, or charge the battery. An explosion could occur causing serious injury or death.

3. Inspect the vehicle to be used for jump-starting to determine if voltage and ground polarity are compatible. The vehicle must have a 12-volt DC, negative ground electrical system.

CAUTION

Always make sure the electrical systems are of the same voltage and ground polarity prior to connecting jumper cables. If not, severe electrical damage could occur.

4. Move the vehicle to be used for the jump-start close enough to ensure the jumper cables easily reach; then shift into neutral, set and lock the brakes, shut off all electrical accessories, and turn the ignition switch OFF.

■ **NOTE: Make sure all switches on the vehicle to be jump-started are turned OFF.**

5. Disconnect all external accessories such as cell phones, GPS units, and radios on both vehicles.

CAUTION

Failure to disconnect electronic accessories during jump-starting may cause system damage due to power spikes.

6. Attach one clamp of the positive (red) jumper cable to the positive (+) terminal (1) of the dead battery (C) being careful not to touch any metal with the other clamp; then attach the other clamp of the positive (red) jumper cable to the positive (+) terminal (2) of the good battery (B).

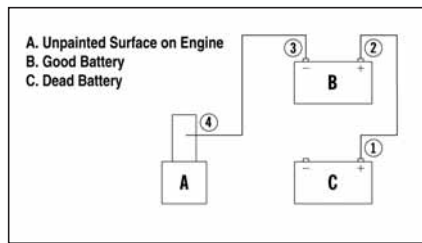

0744-527

■ **NOTE:** Some jumper cables may be the same color but the clamps or ends will be color-coded red and black.

- Attach one clamp of the negative (black) jumper cable to the negative (-) terminal (3) of the good battery (B); then attach the other clamp of the negative (black) jumper cable (4) to an unpainted metal surface (A) on the engine or frame well away from the dead battery and fuel system components.

⚠ WARNING

Never make the final connection to a battery as a spark could ignite hydrogen gases causing an explosion of the battery resulting in acid burns or blindness.

- Stand well away from the dead battery and start the vehicle with the good battery. Allow the vehicle to run for several minutes applying some charge to the dead battery.
- Start the vehicle with the dead battery and allow it to run for several minutes before disconnecting the jumper cables.
- Remove the jumper cables in opposite order of hook-up (4, 3, 2, 1). Be careful not to short cables against bare metal.

■ **NOTE:** Have the battery and electrical system checked prior to operating the vehicle again.

Spark Plug

This vehicle comes equipped with a specified spark plug. See the specifications chart for the correct spark plug. A light brown insulator indicates that the plug is correct. A white or dark insulator indicates that the engine may need to be serviced. Consult an authorized Toro ROV dealer if the plug insulator is not a light brown color. To help prevent cold weather fouling, make sure to thoroughly warm up the engine before operating.

To maintain a hot, strong spark, keep the plug free of carbon.

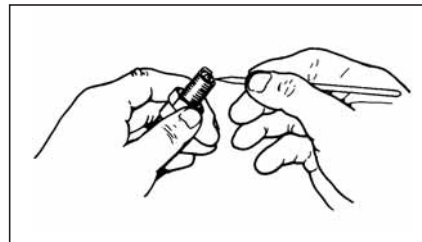

ATV-0051

Before removing the spark plug, clean the area around the spark plug. If you do not, dirt could enter engine when removing or installing the spark plug.

Adjust the gap to proper specification (see Specifications chart) Use a feeler gauge to check the gap.

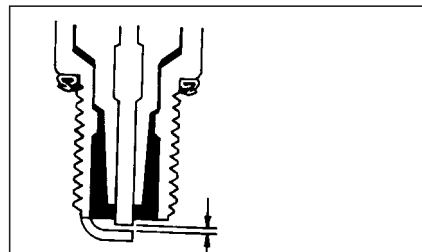

ATV-0052

A new spark plug should be tightened 1/2 turn once the washer contacts the cylinder head. A used spark plug should be tightened 1/8 - 1/4 turn once the washer contacts the cylinder head.

Air Inlet Pre-Filter

This vehicle is equipped with a foam pre-filter to filter dirt from the inlet air prior to reaching the main air filter.

1. Raise the cargo box; then gently squeeze the pre-filter cover and lift it up to expose the pre-filter.



HDX237A

2. Loosen the clamp securing the pre-filter.



HDX235

3. Remove the pre-filter assembly and wash thoroughly in warm, soapy water; then rinse and dry.
4. Install and secure with the clamp. Tighten securely; then with the pre-filter cover installed, lower the cargo box.

Air Filter

The air filter inside the air filter housing must be kept clean to provide good engine power and gas mileage. If the vehicle is used under normal conditions, service the filter at the intervals specified in the Maintenance Schedule. If operated in dusty, wet, or muddy conditions, inspect and service the filter more frequently. Use the following procedure to remove the filter and inspect and/or clean it.

CAUTION

Failure to inspect the air filter frequently if the vehicle is used in dusty, wet, or muddy conditions can damage the engine.

■ **NOTE: To access the air filter, raise the cargo box.**

1. Remove dirt and debris from around the filter housing.
2. Unsnap the four spring-clip fasteners and remove the air filter cover.



HDX050A

3. Remove the two knobs securing the filter; then remove the metal hold-down and filter.



HDX226A

4. Fill a wash pan larger than the element with soapy water; then dip the element in the soapy water and wash it.
5. Squeeze the element by pressing it between the palms of both hands to remove excess soapy water. Do not twist or ring the element or it will tear.
6. Dry the element.
7. Put the element in a plastic bag; then pour in air filter oil and work the oil into the element.

- Squeeze the element to remove excess oil.

CAUTION

A torn air filter can cause damage to the engine. Dirt and dust may get inside the engine if the element is torn. Carefully examine the element for tears before and after cleaning it. Replace the element with a new one if it is torn.

- Clean any dirt or debris from inside the filter housing.
- Install the air filter and metal hold-down, secure with the two knobs tightened to 16 N-m (12 ft-lb), and install the cover. Secure with the four clips.
- Lower the cargo box.

Air Filter Housing Drains

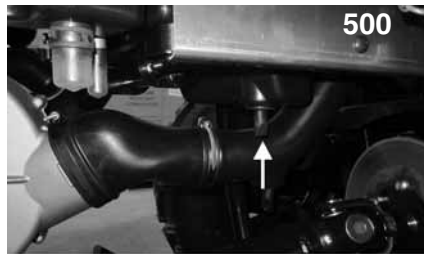

TC033A



TC034A

Inspect and squeeze the “duck bill” drain beneath the main housing for debris and for proper sealing.

Remove the tube drain and clean out any water, oil, or debris. Reinstall and secure with the clamp.

Draining V-Belt Cover

■ **NOTE:** If the vehicle has been driven through water, the V-belt cover must be drained of any water.

- Place the vehicle on a level surface.
- From the right-rear of the vehicle, remove the drain bolt from the cover and allow the water to drain out.

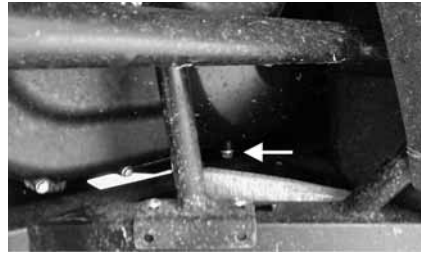

TC025A

- Move the shift lever to the neutral position; then start the engine.

CAUTION

Do not attempt to clear water with the vehicle in park. The transmission is locked and belt or clutch damage could occur.

- Increase and decrease engine RPM several times to “blow out” any water; then stop the engine.
- Install the drain bolt and tighten securely.

■ **NOTE:** The V-belt and pulleys should be inspected every 500 miles and the belt replaced (if necessary).

Tires

⚠ WARNING

Always use the size and type of tires as specified. Refer to the specifications chart for proper tire inflation pressure, and always maintain proper tire inflation pressure.

Tire Tread Condition

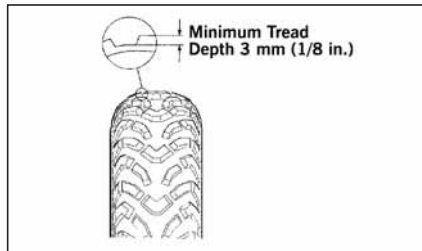

0732-649

The use of worn-out tires on this vehicle is very dangerous. A tire is considered to be worn out when the depth of the tread is less than 3 mm (1/8 in.). Be sure to replace the tires before reaching this minimum specification.

⚠ WARNING

The use of worn-out tires is dangerous and can increase the risk of an accident.

Tire Replacement

This vehicle has low-pressure tubeless tires. Have this maintenance performed by an authorized Toro ROV dealer or a qualified tire repair station.

⚠ WARNING

Use only Toro approved tires when replacing tires. Failure to do so could result in unstable operation.

Tubeless Tire Repair

Should a leak or flat tire occur due to a puncture, the tire may be repaired using a plug-type repair. If the damage is from a cut or if the puncture cannot be repaired using a plug, the tire must be replaced. When operating the vehicle in areas where transportation or service facilities are not readily available, it is strongly recommended to carry a plug-type repair kit and a tire pump along.

Wheels

1. Park the vehicle on level ground and with the transmission in park, engage 4WD/differential lock.
2. Loosen the lug nuts on the wheel to be removed.

3. Elevate the vehicle.
4. Remove the lug nuts.
5. Remove the wheel.
6. Install the wheel; then using a criss-cross pattern, tighten the wheel nuts in 27 N-m (20 ft-lb) increments to the final torque shown in the table below.

Steel Wheel	54 N-m (40 ft-lb)
Aluminum Wheel (Black Nuts)	80 N-m (60 ft-lb)
Aluminum Wheel (Chrome Nuts)	108 N-m (80 ft-lb)



PR941A

CAUTION

Using an impact wrench could result in incorrect torque which could damage the wheel or hub studs.

7. Remove the jack.

Muffler/Spark Arrester

The muffler has a spark arrester which must be periodically cleaned. At the intervals shown in the Maintenance Schedule, clean the spark arrester using the following procedure.

⚠ WARNING

Wait until the muffler cools to avoid burns.

1. Open the cargo box and remove the two springs securing the muffler to the exhaust pipe.

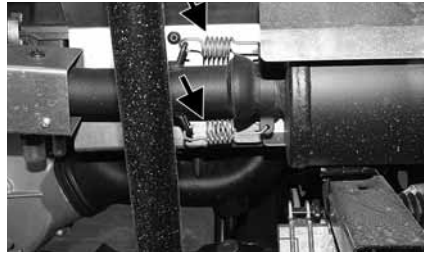

HDX238A

2. Remove the muffler by pulling it rearward out of the vehicle.
3. Remove the heat shield.



HDX241A

4. Remove the three cap screws securing the exhaust pipe/spark arrester assembly to the muffler.

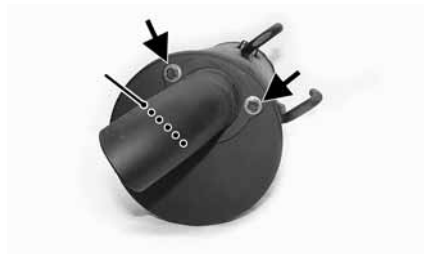

HDX243A

5. Using a wire brush, clean the carbon deposits from the screen taking care not to damage the screen.



HDX242

■ **NOTE: If the screen or gasket is damaged in any way, it must be replaced.**

6. Install the exhaust pipe/spark arrester assembly and secure with the three cap screws. Tighten to 6.8 N-m (60 in.-lb).
7. Install the heat shield and tighten the fasteners to 8.1 N-m (72 in.-lb).
8. Install the muffler and secure it to the exhaust pipe with the two springs.

Light Bulb Replacement

The wattage rating of each bulb is shown in the chart. When replacing a burned out bulb, always use the same wattage rating.

Headlight	12V/27W (4)
Taillight/Brakelight	12V/8W/27W

CAUTION

Use only specified bulbs indicated in the chart as replacement bulbs.

CAUTION

The bulb portion of the headlight is fragile. **HANDLE WITH CARE.** When replacing the headlight bulb, do not touch the glass portion of the bulb. If the glass is touched, it must be cleaned with a dry cloth before installing. Skin oil residue on the bulb will shorten the life of the bulb.

To replace the headlight bulb, use the following procedure.

1. Remove the wiring harness connector from the back of the headlight.
2. Grasp the bulb housing, turn it counterclockwise, and remove the housing. Remove the bulb.

3. Install the new bulb into the housing; then install the housing and rotate it completely clockwise.
4. Install the wiring harness connector.

To replace the taillight/brakelight bulb, use the following procedure.

1. Remove the mounting screws securing the taillight/brakelight assembly to the rear ROPS tube.
2. Rotate the socket counterclockwise and remove it from the housing.
3. To remove the bulb from the socket, pull it straight out of the socket.
4. To install the bulb, push it straight into the socket.
5. Insert the socket into the housing and rotate it clockwise.
6. Position the taillight/brakelight assembly on the rear ROPS tube; then tighten the mounting screws securely.

Checking/Adjusting Headlight Aim

The headlights can be adjusted vertically. The center of the HIGH beam light zone is to be used for aiming.

1. Position the vehicle on a level floor so the headlights are approximately 6.1 m (20 ft) from an aiming surface (wall or similar aiming surface).

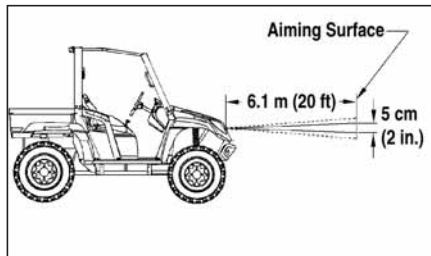

0740-647

■ **NOTE:** There should be an average operating load on the vehicle when adjusting the headlight aim.

2. Measure the distance from the floor to the mid-point of each headlight.

3. Using the measurements obtained in step 2, make horizontal marks on the aiming surface.
4. Make vertical marks which intersect the horizontal marks on the aiming surface directly in front of the headlights.
5. Switch on the lights. Make sure the HIGH beam is on. **DO NOT USE LOW BEAM.**
6. Observe each headlight beam aim. Proper aim is when the HIGH beam is centered on the vertical mark 5 cm (2 in.) below the horizontal mark on the aiming surface.
7. Turn the adjuster nut clockwise to raise the beam and counterclockwise to lower the beam.

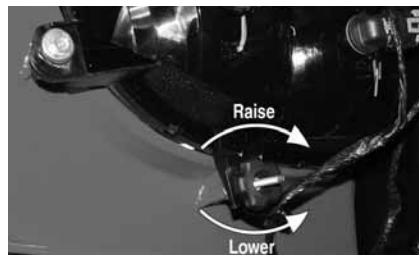

TC004A

Fuses

The fuses are located in a power distribution module under the driver seat. If there is any type of electrical system failure, always check the fuses first.

■ **NOTE:** To remove the fuse cover, compress the locking tabs on either side of the fuse cover and lift out.

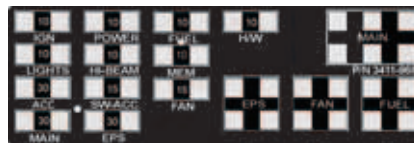

3411-968

CAUTION

Always replace a blown fuse with a fuse of the same type and rating. If the new fuse blows after a short period of use, consult an authorized Toro ROV dealer immediately.

■ **NOTE:** Extra fuses are located inside the fuse cover.



TC035

Electrical Output Terminals

Two output terminals for electrical accessories are located on the front and rear wiring harnesses.

■ **NOTE:** The rear output terminal is located near the left-side of the throttle body. The front output terminal is located beneath the dashboard in front of the left-side accessory plug.

Two accessory plugs are located on the dashboard. These plugs are always on and are not switched off with the ignition switch.

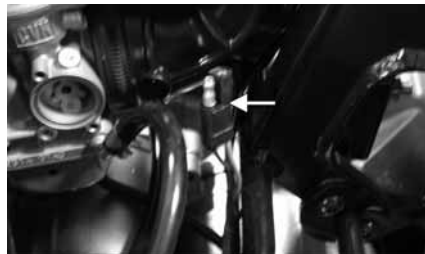

PR049A

CAUTION

Always use electrical accessories less than 180W.

Storage Compartment/Tools

This vehicle has a storage compartment within the dashboard.

A basic tool kit located under the seat (passenger side) is provided with this vehicle. Maintain the tool kit with the vehicle at all times.



TC032

Seat Belts

Inspect the seat belts for frayed or torn edges. Check that the belts extend and retract smoothly and fully without binding or catching. Check that the latch plate locks securely in place in the buckle and releases when the button is pressed. Wash off any dirt and make sure the retractors are free of debris. Do not grease or oil the retractors.

Occupant Side Restraints

Inspect the occupant side restraints for frayed edges, cuts, or separation of seams. Wash off any dirt and make sure the latch straps lock securely into the foot restraints with straps taut.



HDX187

ROPS

Inspect the Rollover Protection Structure (ROPS) for any deformation, twisting, cracking, missing or damaged fasteners, loose fasteners, modification to the production form, missing ROPS label, unauthorized repair or welding, and/or improper installation. If any of these circumstances are discovered, immediately bring the vehicle to an authorized Toro ROV dealer for service.

Preparation for Storage

Toro recommends the following procedure to prepare the vehicle for storage. An authorized Toro ROV dealer should perform this service; however, the owner/operator may perform this service if desired.

CAUTION

Prior to storing this vehicle, it must be properly serviced to prevent rusting and component deterioration.

1. Clean the seat cushions with a damp cloth and allow to dry.
2. Clean the vehicle thoroughly by washing dirt, oil, grass, and other foreign matter from the entire vehicle. Allow the vehicle to dry thoroughly. DO NOT get water into any part of the engine or air intake.
3. Either drain the gas tank or add a fuel stabilizer to the gas in the gas tank.
4. Clean the interior of the air filter housing.
5. Plug the hole in the exhaust system with a clean cloth.
6. Apply light oil to the upper steering shaft bushing and plungers of the shock absorbers.
7. Tighten all nuts, bolts, cap screws, and screws. Make sure rivets holding components together are tight. Replace all loose rivets. Care must be taken that all calibrated nuts, cap screws, and bolts are tightened to specifications.
8. Fill the cooling system to the bottom of the stand pipe in the radiator neck with properly mixed coolant.
9. Disconnect the battery cables (negative cable first); then remove the battery, clean the battery posts and cables, and store in a clean, dry area.

■ **NOTE: For storage, use a battery maintainer or make sure the battery is fully charged (see Battery section in this manual).**

10. Store the vehicle indoors in a level position.

CAUTION

Avoid storing outside in direct sunlight and avoid using a plastic cover as moisture will collect on the vehicle causing rusting.

Preparation after Storage

Taking this vehicle out of storage and correctly preparing it will assure many miles and hours of trouble-free riding. Toro recommends the following procedure.

1. Clean the vehicle thoroughly.
2. Clean the engine. Remove the cloth from the exhaust system.
3. Check all control wires and cables for signs of wear or fraying. Replace if necessary.
4. Change the engine/transmission oil and filter.
5. Check the coolant level and add properly mixed coolant as necessary.
6. Charge the battery; then install. Connect the battery cables making sure to connect the positive cable first.
7. Check the entire brake systems (fluid level, pads, etc.), all controls, headlights, taillight, brakelight, and headlight aim; adjust or replace if necessary.
8. Check the tire pressure. Inflate to recommended pressure as necessary.
9. Tighten all nuts, bolts, cap screws, and screws making sure all calibrated nuts, cap screws, and bolts are tightened to specifications.
10. Make sure the steering moves freely and does not bind.
11. Check the spark plug. Clean or replace as necessary.
12. Follow the recommendations found in the pre-start inspection.

CAUTION

Before installing the battery, make sure the ignition switch is in the OFF position.

Limited Warranty

The Toro Company (hereinafter referred to as Toro) extends a limited warranty as described below on each new Toro ROV it assembles and on each genuine Toro ROV part and accessory assembled and sold by an authorized Toro ROV dealer. The limited warranty on a Toro ROV is extended to the original retail purchaser for the time periods described below; however, the balance of the remaining warranty may be transferred to another party. Warranty coverage is only available in the country in which the original retail purchase occurs to the original retail purchaser resident in that country or to a transferee resident in that country of the balance of the remaining warranty.

Toro warrants only the products it assembles and/or sells and does not warrant that other products will function properly when used with a Toro ROV or will not damage the ROV. Toro does not assume any liability for incidental or consequential damages.

Toro will repair or replace, at its option, free of charge (including any related labor charges), any parts that are found to be warrantable in material or workmanship. This repair work MUST be done by an authorized Toro ROV dealer. No transportation charges, rental charges, or inconvenience costs will be paid by Toro. The warranty is validated upon examination of said parts by Toro or an authorized Toro ROV dealer. Toro reserves the right to inspect such parts at its factory for final determination if warranty should apply.

The warranty periods are as follows:

1. One year from the original date of sale or 1000 operational hours, whichever occurs first.
2. Thirty days from the original date of sale of a Toro ROV on batteries.

Exclusions to this warranty include normal wear, abuse, or corrosion and the following parts and items:

Tires	Drive/Driven Clutch Wear Parts
Oil Filter	Drive Belt
Air Filter	Torn or Punctured Upholstery
Brake Pads	Cracks or Gouges in Body Panels
Light Bulbs	Spark Plug(s)
CV Boots	Windshield

The following will VOID Toro's warranty:

1. Failure to perform the proper break-in procedure and all related maintenance, storage procedures (if stored for extended periods), and/or service as recommended in the Operator's Manual.
2. Repairs and/or adjustments by anyone other than an authorized Toro ROV dealer.
3. Use of improper gasoline, lubricating oils, or spark plug(s).
4. An accident or subjecting the ROV to misuse, abuse, or negligent operation.
5. Any modification, addition, or removal of parts unless instructed to do so by Toro.
6. Use of the ROV in any way for racing purposes.
7. Removal of the engine for use in another vehicle.
8. Removal or mutilation of the Vehicle Identification Number or Engine Serial Number.
9. Use of parts not sold or approved by Toro.
10. Damage due to improper transportation.

Toro shall not be responsible for and this limited warranty excludes recovery of economic, punitive, consequential and incidental damages, lost profits, and loss of use. Some states or provinces do not allow the exclusion or limitation of incidental or consequential damages, so the above limitation may not apply to you. Toro's aggregate liability may not exceed the price of the product. The law of the State of Minnesota shall apply to all claims or disputes, exclusive of its conflicts of law provisions.

IMPLIED WARRANTY EXCLUSION AND DISCLAIMER

To the fullest extent permitted by law, Toro excludes and disclaims all implied warranties of merchantability and fitness for a particular purpose.

If you are not satisfied with warranty service or repairs, you should contact The Toro Company at 844-521-2383.

Warranty Procedure/Owner Responsibility

At the time of sale, an Owner Registration form is to be completed by the selling dealer and consumer. The receipt of the form by Toro is a condition precedent to warranty coverage. It is the selling dealer's responsibility to retain and/or submit appropriate copies of the form to the appropriate place(s) to initiate warranty coverage.

The dealer will furnish to the consumer a signed copy of the form which must be presented to the dealer when requesting warranty service. The registration form is the consumer's proof of ownership and warranty eligibility. The form is used by the dealer to validate the warranty claim. Retain your copy of the form and keep it in a safe place.

When warranty repair is suspected, the ROV should be taken to the selling dealer, who has the primary responsibility to perform warranty repairs. Subject to the limitations set forth in the Limited Warranty, in the event the selling dealer has ceased to do business, you have moved, or you are in a location away from your selling dealer, warranty may be performed by any authorized Toro ROV dealer.

The authorized Toro ROV dealer will examine the ROV or part to determine if, in his opinion, a warrantable condition exists. If a warrantable condition appears to exist, the dealer will repair or replace, at Toro's option, free of charge, including any related labor costs, all parts that are found to be warrantable and any other parts which the warrantable part caused to be damaged. You, the owner, will then be asked to sign a warranty form to ensure Toro that the warranty work was actually performed.

It is the owner's responsibility to maintain and service the ROV in accordance with Toro's recommendations in the Operator's Manual. To protect yourself and your ROV, follow all safety and service tips. Toro will NOT warrant repairs required as a result of not performing standard operator maintenance, storage procedures, and service as outlined in the Operator's Manual.

Should you have any questions concerning the warranty, contact an authorized Toro ROV dealer.

U.S. EPA Emission Control Statement/Warranty Coverage (U.S. Only)

STATEMENT/WARRANTY

The Toro Company warrants to the original retail purchaser, and each subsequent purchaser, that all U.S. EPA-certified Toro ROV's are designed, built, and equipped to conform to all U.S. EPA Emission Control Regulations. Please read the following information completely.

Your authorized Toro ROV dealer will repair or replace any defective emission-related component at no cost to you during the warranty period. You may have non-warranty service performed by any repair establishment that uses equivalent components. The regulations provide significant civil penalties for tampering that causes your ROV to no longer meet U.S. EPA emission standards.

Toro further warrants that the engine and its emission-related components are free from defects in materials or workmanship that could cause the engine to fail to comply with applicable regulations during the warranty period.

If you have any questions about this information, or the emission warranty coverage statement, contact your local authorized Toro ROV dealer.

WARRANTY PERIOD

The emission warranty period for this ROV begins on the same date as the standard warranty coverage and continues for 30 months or 3100 miles, whichever comes first.

COMPONENTS COVERED

The emissions warranty covers major emissions control components and emission-related components listed as follows:

Engine Management and Sensors

Barometric Pressure Sensor
Camshaft Position Sensor
Engine Control Module (ECM)
Engine Coolant Temperature Sensor
Intake Air Temperature Sensor
Manifold Absolute Pressure Sensor
Oxygen Sensor
Throttle Position Sensor
Crankshaft Position Sensor
Exhaust Temperature Sensor

Ignition System

Ignition Coil
Knock Sensor System
Spark Plugs
Capacitive Discharge Ignition (CDI) Module
Magneto Pick-Up

Fuel/Air System

Fuel Injectors
Fuel Pressure Regulator
Fuel Pump
Carburetor(s)
Turbocharger Assembly
Air Bypass Valve
Turbo Waste Gate Control Valve
Crankcase Ventilation System
ISC Valve

Miscellaneous Items Used in Aforementioned Systems

Connectors
Switches
Grommets
Clamps
Hoses
Ties
Gaskets
Wiring

OWNER'S RESPONSIBILITIES

The owner of any ROV warranted under this Toro Emission Control Statement is responsible for the proper maintenance and use of the ROV as stated in the Operator's Manual. Proper maintenance generally includes replacement and service, at the owner's choosing, such items as air filter, oil and oil filter, or any other part, item, or device related to emissions control as specified in the Operator's Manual. It is the owner's responsibility to ensure that the ROV is used in a manner for which it was designed.

NOTES

Change of Address, Ownership, or Warranty Transfer

The Toro Company keeps on file the current name and address of the owner of this vehicle. This allows Toro to reach the current owner with any important safety information which may be necessary to protect customers from personal injury or property damage. Please make sure a copy of this form is completed and returned to Toro if you move or if the vehicle is sold to another party.

This form may also be used to transfer the unused portion of the original warranty to a second party. In order to transfer warranty, fill out this form completely; then return a copy of this form to Toro. Toro will then process the application and issue warranty for the balance of the time remaining of the original warranty. Warranty coverage is only available in the country in which the original retail purchase occurs to the original retail purchaser resident in that country or to a transferee resident in that country of the balance of the remaining warranty.

- Address Change
- Ownership Change
- Warranty Transfer

**CHANGE OF ADDRESS/OWNERSHIP/
WARRANTY TRANSFER TO:**

Name _____
Address _____
City/State (Province)/Zip Code (Postal Code) _____
Phone # () _____
Email _____
Year and Model Number _____
Serial Number _____

Fold Back

CHANGE OF ADDRESS/OWNERSHIP

Place
Stamp
Here

The Toro Company
Warranty Dept.
8111 Lyndale Ave. S
Bloomington, MN 55420

Identification Numbers Record

This vehicle has three identification numbers: Model Number, Serial Number, and Engine Serial Number (ESN).

These numbers are required by the dealer to complete warranty claims properly. No warranty will be allowed by Toro if the numbers are removed or mutilated in any way.

Always provide the name, Model Number, Serial Number, and ESN when contacting an authorized Toro ROV dealer for parts, service, accessories, or warranty. If a complete engine must be replaced, ask the dealer to notify Toro for correct registration information.

Record the Model Number, Serial Number, and ESN in the spaces provided to assist you in ordering parts from your authorized Toro ROV dealer or for reference in case this vehicle is stolen.

1. MODEL NUMBER:

The Model Number is located at the rear of the vehicle on the verticle frame tube.

2. SERIAL NUMBER:

The Serial Number is located on the frame support tube under the cargo box facing the rear of the vehicle.

3. ENGINE SERIAL NUMBER (ESN):

The ESN is located on the left-side of the engine crankcase near the bottom of the crankcase.





WARNING

Improper use can result in **SEVERE INJURY** or **DEATH**



ALWAYS USE
AN APPROVED
HELMET AND
PROTECTIVE
GEAR



NEVER USE
ON PUBLIC
HIGHWAYS



OPERATORS
MUST BE 16
YEARS OLD
OR OLDER AND
HAVE VALID
DRIVER'S LICENSE



NEVER USE
WITH DRUGS
OR ALCOHOL

NEVER USE:

- before reading the Operator's Manual carefully.
- at speeds too fast for your skills or the conditions.
- on public highways where a collision with cars or trucks can occur.
- operate through water deeper than floorboard level or fast flowing water.

ALWAYS:

- use proper driving techniques to avoid overturns on hills and rough terrain and in turns.
- wear your seat belt and require others to wear their seat belt.
- keep arms and legs inside the structure.

Operators must be 16 years or older and have a valid driver's license, and minors must be supervised by an adult.

Vehicle Capacity: 1 Operator, 2 Passengers with seat belts

**LOCATE AND READ OPERATOR'S MANUAL
FOLLOW ALL INSTRUCTIONS AND WARNINGS**