

TORO[®]**SIDE DISCHARGE KIT**

MODEL NO. 59199

**INSTALLATION
INSTRUCTIONS**

Since this instruction sheet covers only a minimal amount of information necessary to maintain and operate your mower, we suggest that you keep this material with your Operator's Manual so that both may be referred to for instructions concerning safe operation and proper maintenance procedures.

Kit Contents

DESCRIPTION	QTY.
Side Discharge Chute	1
Installation Instruction Sheet	1

Operation

Using Side Discharge Chute

1. Stop the engine and wait for all moving parts to stop.
2. Ensure discharge door handle is fully forward (Fig. 1).

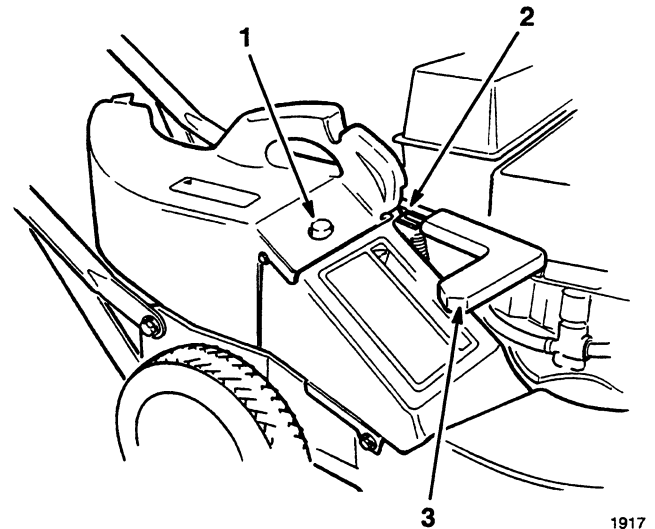
**Figure 1**

1. Chute frame on retaining post
2. Pin
3. Handle fully forward—discharge door closed

3. **INSTALLING CHUTE**—Slide hole in side discharge chute onto retaining post on discharge tunnel (Fig. 1).

IMPORTANT: Chute tab must be positioned in front of wide portion of rear housing wall as shown in Figure 2.

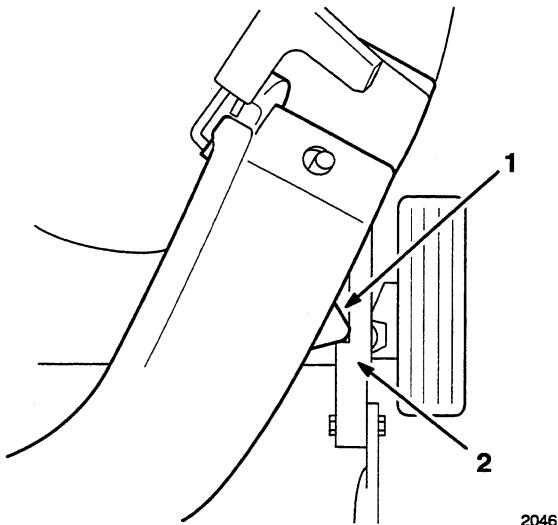
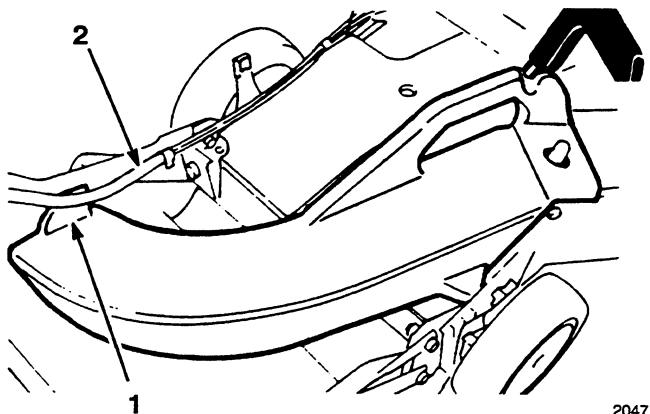

Figure 2

1. Chute tab
2. Wide portion of rear housing wall

IMPORTANT: On self-propelled mowers, hook the control cables behind the cable tab on the end of the side discharge chute (Fig. 3).



Self-propelled models

Figure 3

1. Cable tab
2. Control cables

4. Pull discharge door handle forward until pin clears catch and move handle rearward until pin locks in chute notch (Fig. 4). Discharge door in mower housing is now open.

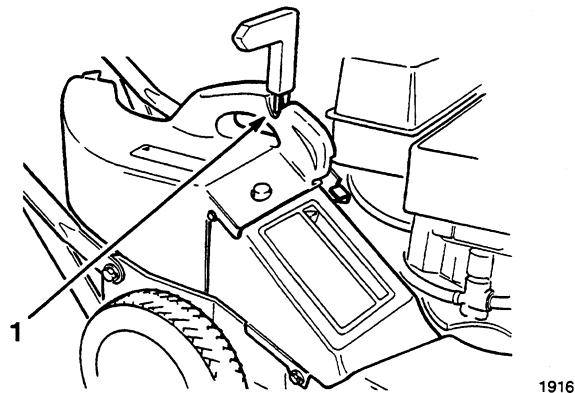

Figure 4

1. Pin in chute notch

! DANGER

POTENTIAL HAZARD

- Grass clippings and other objects can be thrown from an open discharge tunnel.

WHAT CAN HAPPEN

- Objects thrown with enough force could cause serious personal injury or death to operator or bystander.

HOW TO AVOID THE HAZARD

- Never open door on discharge tunnel when engine is running unless the side discharge chute, discharge tunnel plug or optional grass bag is securely installed.

! DANGER

POTENTIAL HAZARD

- Thrown objects may result if discharge door does not close completely.

WHAT CAN HAPPEN

- Thrown objects can cause serious personal injury or death.

HOW TO AVOID THE HAZARD

- If discharge door cannot be closed because grass clippings clog discharge area, stop engine and gently move discharge door handle back and forth until door can be closed completely. If door still cannot be closed, remove obstruction with a stick, not your hand.