



GARDEN TRACTOR

416-8E

**SET UP
INSTRUCTIONS**

Loose Parts

Note: Use the chart below to identify parts for assembly.

DESCRIPTION	QTY.	USE
Front Wheel Assemblies	2	Installing the front wheels
Shim Washer – .015" (.38 mm) thick	2	
Shim Washer – .050" (1.27 mm) thick	4	
Hubcap Washer	2	
Cotter Pin	2	
Hubcap	2	
Logo Hubcap (optional on some models)	2	
Rear Wheel Assembly	2	Installing the rear wheels
Wheel Bolt	10	
Logo Hubcap (optional on some models)	2	
Steering Wheel	1	Installing the steering wheel
Flat Washer – .120" (3 mm) thick	2	
Bowed Washer	1	
Roll Pin	1	
Seat Assembly	1	Installing the seat
Spacer - small I.D.	2	
Spacer - large I.D.	2	
Shoulder Bolt	2	
Hand Knob	2	
Flat Washer	2	
Bolt – 1/4"-20 x 3/4" (19 mm)	2	Attaching the battery cables
Hex Nut – 1/4"-20	2	

DESCRIPTION	QTY.	USE
Hitch Pin	1	Installing the hitch pin
Hairpin Cotter	1	
Flat Washer – 1/2" (13 mm)	1	
Hairpin Cotter	1	Attaching accessory to lift bar
Flat Washer – 1/2" (13 mm)	1	
Spare Key	1	Use in ignition switch
Operator's Manual	1	Attach to tractor
Set Up Instructions	1	Setting up tractor
Maintenance Checklist	1	Attach to underside of hood
Riding Mower Safety Video	1	Attach to tractor

Installing the Front Wheels

1. Install one .050" (1.27 mm) thick shim washer onto each spindle, then install the front wheels onto the spindles with the valve stems facing inward (Fig 1).
2. Install one 1-1/2" (38 mm) O.D. hubcap washer onto each spindle, then insert the cotter pin into the hole in the spindle (Fig. 1).
3. Check the front wheel end play. Install shim washers between the wheels and hubcap washers as necessary so the end play on both front wheels is 0–.015" (0–.4 mm) (Fig 1).
4. Secure the wheels to the spindles with the cotter pins. Bend the ends of the cotter pins around the spindles as shown in the detail drawing in Fig. 1.
5. Install the hubcaps onto the hubcap washers. If the tractor is equipped with logo hubcaps, install the logo hubcaps onto the front wheels (Fig. 1).
6. Grease the wheel bearing fittings to make sure the bearings are packed with grease. Wipe off any excess grease.

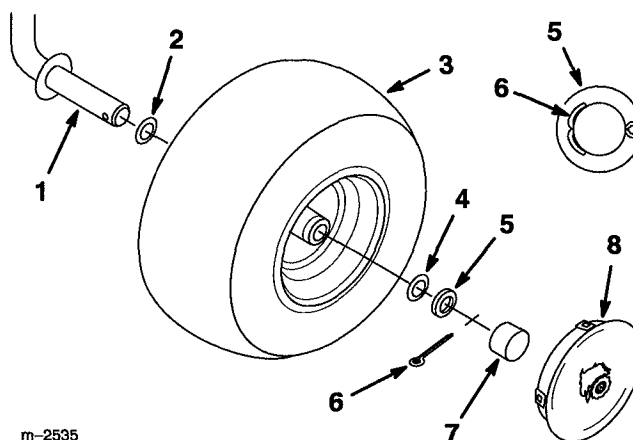

m-2535

Figure 1

- | | |
|--------------------------------|---------------------------|
| 1. Spindle | 5. Hubcap Washer |
| 2. .050" (1.27 mm) Shim Washer | 6. Cotter Pin |
| 3. Front Wheel | 7. Hubcap (standard) |
| 4. Shim Washer (as needed) | 8. Logo Hubcap (optional) |

7. With the tractor on a level surface, check to make sure the front wheel toe-in is between 1/8" and 1/4" (3–6 mm). For instructions on adjusting the toe-in, refer to the Maintenance section in the Operator's manual.

Installing the Rear Wheels

1. Remove the wheel bolts holding the rear shipping brackets to the rear hubs.
2. Before you install the rear wheels, loosen the two jam nuts on the inside of both rear hubs and make sure the two square-head setscrews are torqued to 28–32 ft-lb (38–43 N•m). Tighten the jam nuts to 13–21 ft-lb (18–28 N•m).
3. Install the wheels onto the hubs with the valve stems facing inward (Fig. 2).
4. Torque the wheel bolts to 75–80 ft-lb (105–112 N•m).
5. If the tractor is equipped with logo hubcaps, install the logo hubcaps onto the rear wheels (Fig. 2).

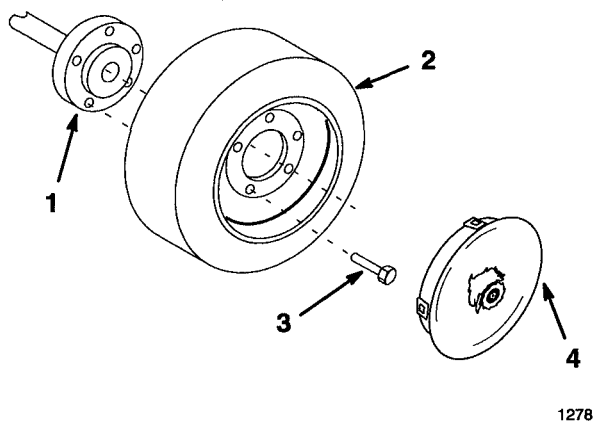

Figure 2

- | | |
|---------------|---------------------------|
| 1. Hub | 3. Wheel Bolt (5) |
| 2. Rear Wheel | 4. Logo Hubcap (optional) |

Checking the Tire Pressure

Check the front and rear tire pressure. The correct front and rear tire pressure is 12 psi (0.8 bar).

Installing the Drawbar Hitch Pin

Insert the drawbar hitch pin into the drawbar hitch and secure it with a 1/2" (13 mm) flat washer and hairpin cotter (Fig. 3).

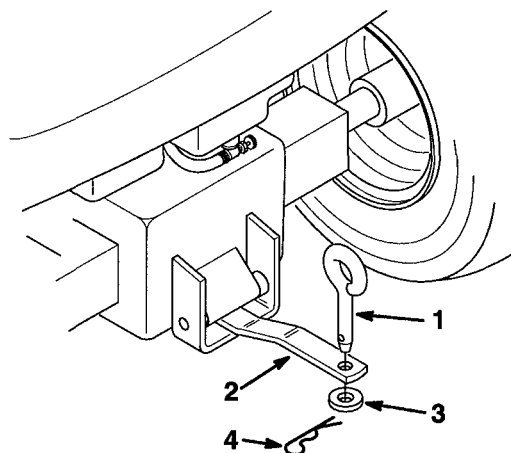

Figure 3

- | | |
|----------------------|-----------------------------|
| 1. Drawbar Hitch Pin | 3. 1/2" (13 mm) Flat Washer |
| 2. Drawbar Hitch | 4. Hairpin Cotter |

Attaching the Washer and Hairpin Cotter onto the Lift Bar

Install a 1/2" (13 mm) flat washer and hairpin cotter onto the lift bar (Fig 4).

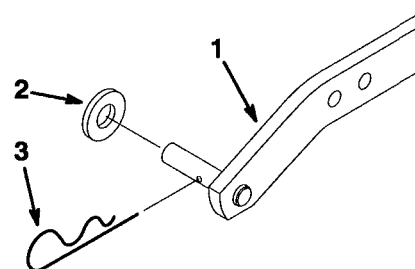

Figure 4

- | | |
|-----------------------------|-------------------|
| 1. Lift Bar | 3. Hairpin Cotter |
| 2. 1/2" (13 mm) Flat Washer | |

Activating the Battery

⚠ DANGER

POTENTIAL HAZARD

- Battery electrolyte contains sulfuric acid which is a deadly poison and it causes severe burns.

WHAT CAN HAPPEN

- If you carelessly drink electrolyte you could die or if it gets onto your skin you will be burned.

HOW TO AVOID THE HAZARD

- Do not drink electrolyte and avoid contact with skin, eyes or clothing. Wear safety glasses to shield your eyes and rubber gloves to protect your hands.
- Fill the battery where clean water is always available for flushing the skin.
- Follow all instructions and comply with all safety messages on the electrolyte container.

1. Remove the battery from the tractor.

Note: Never fill the battery with electrolyte with the battery installed in the tractor.

2. Remove the filler caps from the battery. Slowly pour electrolyte into each cell until the electrolyte level is up to the lower part of the tube (Fig. 5). Use an electrolyte with a specific gravity of 1.265.

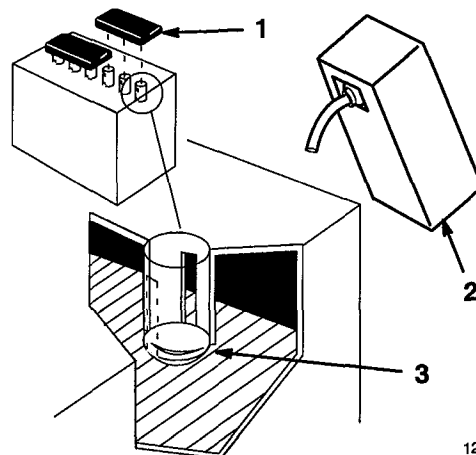

Figure 5

1. Filler Caps
2. Electrolyte
3. Lower part of the tube

⚠ WARNING

POTENTIAL HAZARD

- Charging battery produces gasses.

WHAT CAN HAPPEN

- Battery gasses can explode.

HOW TO AVOID THE HAZARD

- Keep cigarettes, sparks and flames away from battery.

3. Leave the filler caps off and connect a 3–4 amp battery charger to the battery posts (Fig. 6). Charge the battery at a rate of 4 amperes or less for 4 hours (12 volts).
4. When the battery is fully charged, unplug the charger from the electrical outlet, then disconnect the charger leads from the battery posts (Fig. 6).
5. Slowly pour electrolyte into each cell until the level is once again up to the “UPPER” line on the battery case (Fig. 5), then install the filler caps.
6. Install the battery in the tractor and connect the battery cables. (Refer to the Operator’s Manual – Installing the Battery.)

Note: Do not run the tractor with the battery disconnected.

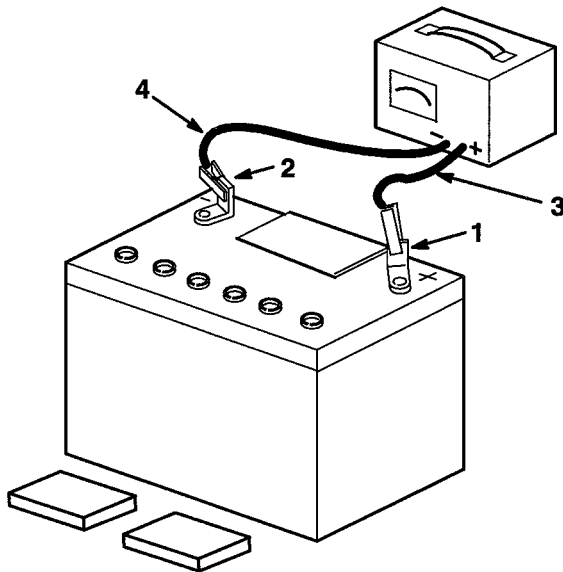

1254

Figure 6

- | | |
|--------------------------|---------------------------|
| 1. Positive Battery Post | 3. Red (+) Charger Lead |
| 2. Negative Battery Post | 4. Black (-) Charger Lead |

Installing the Steering Wheel

1. Position the front wheels so they point straight ahead.
2. Install the steering tube onto the steering wheel shaft with the beveled end down (Fig 7).
3. Install one .120" (3 mm) thick flat washer and the bowed washer onto the steering wheel shaft (Fig 7).

Note: A second flat washer has been provided if needed.
4. Install the steering wheel onto the shaft and align the center spoke (with the TORO logo) with the seat.
5. Secure the steering wheel to the shaft with the roll pin (Fig. 7).
6. If the gap between the steering tube and steering wheel is excessive, remove the steering wheel and install the second .120" (3 mm) thick flat washer underneath the bowed washer (Fig. 7).

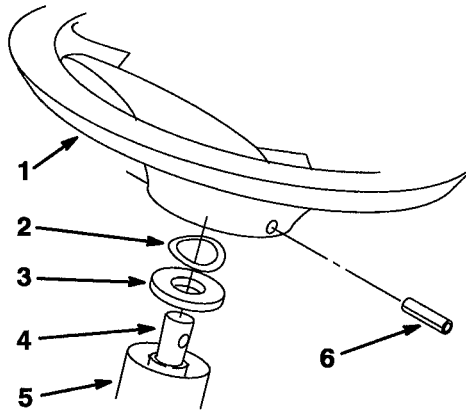

m-2503

Figure 7

- | | |
|-----------------------------------|-------------------------|
| 1. Steering Wheel | 4. Steering Wheel Shaft |
| 2. Bowed Washer | 5. Steering Tube |
| 3. .120" (3 mm) Thick Flat Washer | 6. Roll Pin |

Installing the Seat

1. Install the shoulder bolts and large I.D. spacers into the rear holes in the seat (Fig. 8).
2. Position the seat onto the seat base by inserting the two shoulder bolts through the keyhole openings in the seat base slots. Make sure the large I.D. spacers are positioned between the seat and the seat base (Fig. 8).
3. Locate the small I.D. spacers between the seat and seat base, then thread the hand knobs and flat washers into the front holes in the seat (Fig. 8). Adjust the seat and tighten the knobs.
4. Make sure the seat switch wire is routed correctly through the center slot in the seat base, then push the seat switch connector fully into the wire harness connector on the tractor (Fig. 8).

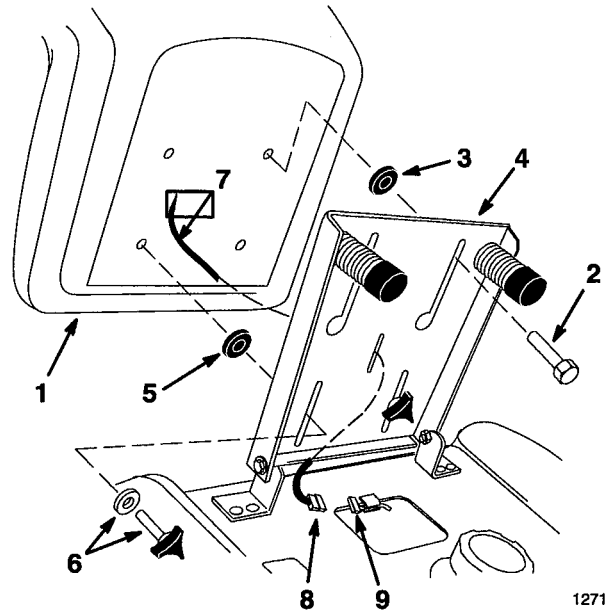

1271

Figure 8

- | | |
|----------------------------|----------------------------------|
| 1. Seat | 6. Hand Knob and Flat Washer (2) |
| 2. Shoulder Bolt (2) | 7. Seat Switch Wire |
| 3. Spacer - Large I.D. (2) | 8. Seat Switch Connector |
| 4. Seat Base | 9. Wire Harness Connector |
| 5. Spacer - Small I.D. (2) | |

Checking the Wiring and Fasteners

- Inspect the tractor for any loose electrical connections and secure as required. Check the wire routing to make sure no moving parts interfere with the wires to cause a short.
- Check all fasteners to make sure they're tight.

Attaching the Maintenance Chart

Attach the MAINTENANCE CHART to the underside of the hood.

Test Driving the Tractor

1. Check the oil level in the crankcase. Refer to the Operator's Manual for oil type, viscosity and crankcase capacity.

Note: When checking the oil level, slide the dipstick all the way into the filler tube, but don't screw the dipstick onto the filler tube.

2. Check the oil level in the transaxle. Refer to the Operator's Manual for oil type, viscosity and capacity.
3. Check to make sure all lubrication points have been greased as shown in the Maintenance section of the Operator's Manual. These points include the front axle, tie rods, foot pedal and steering gear.
4. Fill the tank with unleaded regular gasoline with an octane rating of at least 85. Open the fuel shutoff valve and check the fuel hose and fittings for leaks.

5. As applicable, check and test the operation of the following:

- Engine, choke and throttle controls
- Gauges
- Headlights and taillights
- Indicator lights
- PTO clutch and brake
- Lift system
- Service and parking brakes
- Transmission controls
- Steering
- Tractor operation in forward and reverse

6. Test the operation of the safety interlock system. The engine should **not** crank if:

- The seat is unoccupied
- The clutch is not depressed
- The PTO lever is in the ENGAGED position
- The parking brake is not on

