



REINFORCING KIT for 42" Mower Spindles

PART NO. 93-3105

**INSTALLATION
INSTRUCTIONS**

Loose Parts

Note: Use the chart below to verify all parts have been shipped.

DESCRIPTION	QTY.	USE
Deck Plate-Center	1	Weld onto deck at center spindle.
Deck Plate-Outside	2	Weld onto deck at outer spindles.
Spindle Plate	3	Weld on top of each deck plate.
Washer	2	Spacer between deck and front mount.

Note: Care has been taken in locating deck and spindle plates on the mower deck so mounting holes will line up with existing holes in the deck. Before welding double check that all holes line up and there will be no interference.

Pre-Installation

- 1 Remove mower unit (see Operator's Manual for instructions).
- 2 Thoroughly clean mower deck. All debris must be removed to ensure plates will fit properly against mower deck.
- 3 Repair all bent or damaged areas of mower deck and replace any missing parts.

Installation

- 1 Remove belt covers, blades, anti-scalp cups, spindles and all other brackets or hardware that will interfere with deck plates from mower.
- 2 Remove front belt tightener plate from mower (Fig. 2).
- 3 Place deck plates over center and outside spindle openings as shown (Fig. 1). Align plate bolt holes with bolt holes of mower deck spindle

openings (Fig. 1). Install spindles and clamp deck plates securely in position with mounting hardware previously removed.

- 4 Weld deck plates to mower at center and edges with 1/8" weld bead 1" long at each – (Fig. 1). Do not weld all around. Alternate from side to side to prevent heat build-up and distortion of mower.

Note: Too much heat concentration in one are will cause mower warpage.

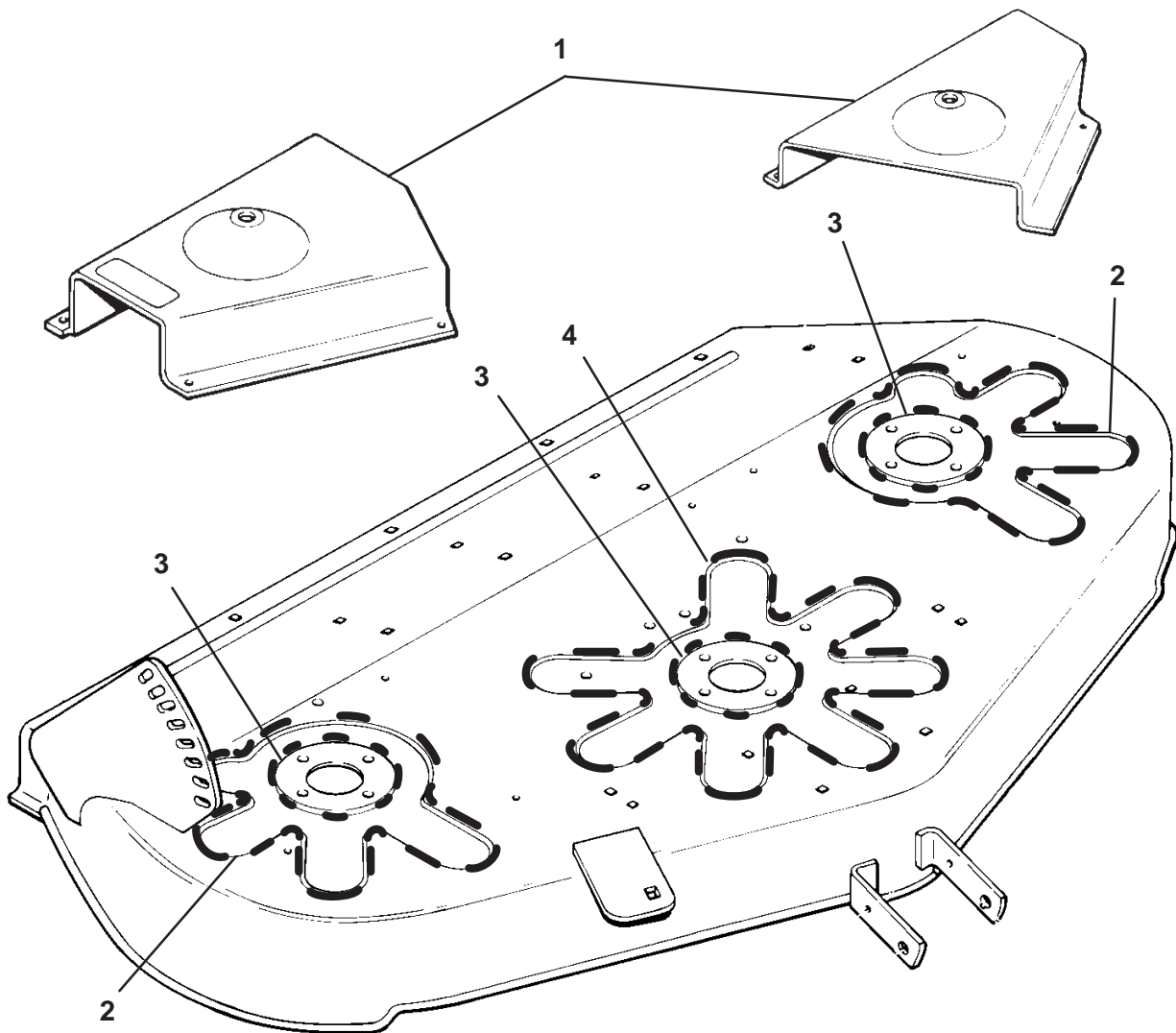

Figure 1

- | | |
|----------------------|---------------------|
| 1 Belt cover | 3 Center deck plate |
| 2 Outside deck plate | 4 Spindle plate |

1542

- 5 Use spacer washers at front holes when mounting front plate over reinforcing plate (Fig. 2).
- 6 Install blades and anti-scalp cups.
- 7 Tighten the blade mounting bolts to 85–110 ft-lb (115–150 Nm).
- 8 Turn mower deck over and install all brackets, hardware and belt covers removed in step 1.
- 9 Install mower deck onto traction unit (see Operator's Manual for instructions).

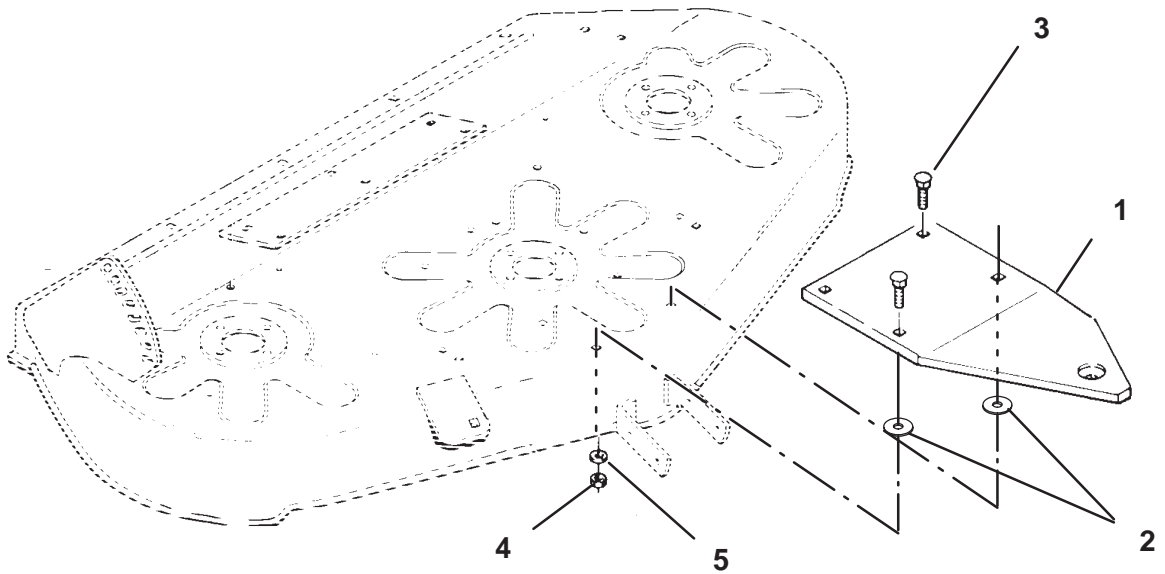

Figure 2

- | | |
|-----------------|----------|
| 1 Plate | 4 Nut |
| 2 Spacer washer | 5 Washer |
| 3 Bolt | |

1543