

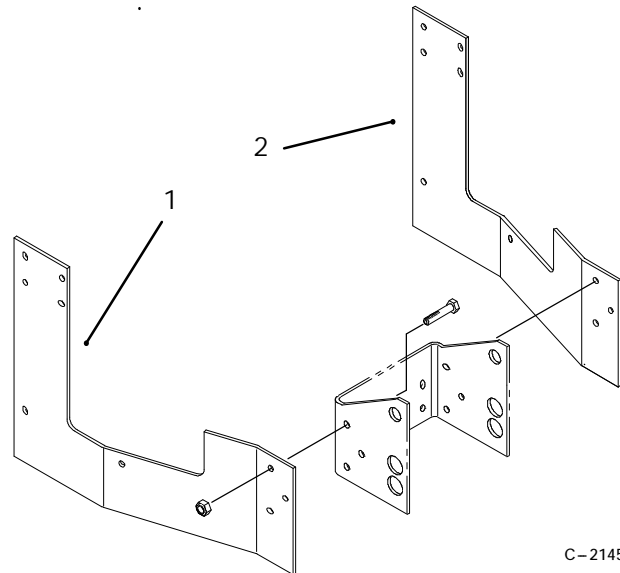

PART NO. 93-3806

INSTALLATION
INSTRUCTIONS

1544 SNOW BLADE ADAPTER KIT



C-2145

1. Bracket - R.H.

2. Bracket - L.H.

Installation

When installing snow blade on 1544 Lawn Tractor, use brackets from kit to mount to frame, in place of brackets shipped with blade.

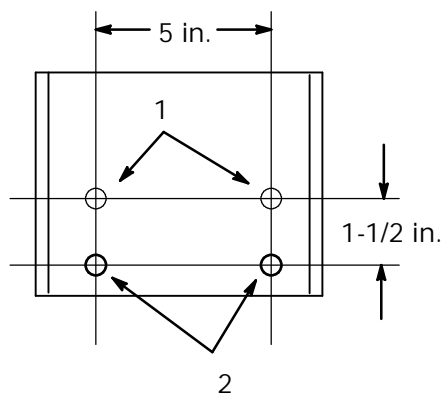

1. Existing holes

2. Lower mounting holes, drill 11/32 in. (.344)

Mount front bracket to tractor using lower mounting holes.

Note: If required, drill two (2) 11/32 in. (.344) holes in front bracket at locations shown.

Follow remaining instructions for snow blade installation in Operator's Manual.