



**Count on it.**

**Operator's Manual**

# GreensPro™ 1240 Greens Roller

Model No. 44912—Serial No. 31500001 and Up

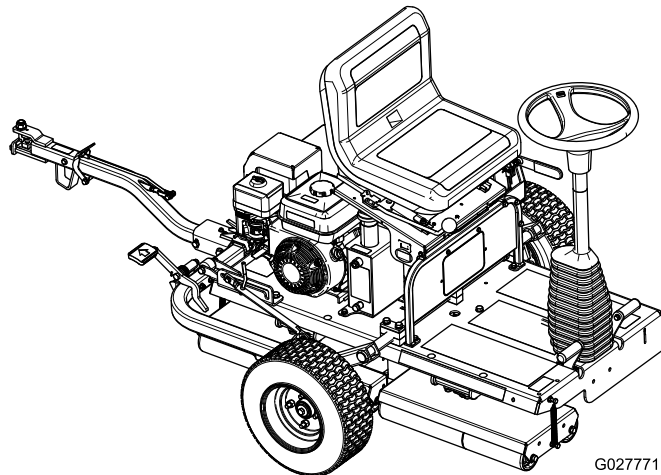

G027771



This product complies with all relevant European directives. For details, please see the separate product specific Declaration of Conformity (DOC) sheet.

**▲ WARNING**

**CALIFORNIA  
Proposition 65 Warning**

**This product contains a chemical or chemicals known to the State of California to cause cancer, birth defects, or reproductive harm.**

**The engine exhaust from this product contains chemicals known to the State of California to cause cancer, birth defects, or other reproductive harm.**

**Important:** This engine is equipped with a spark arrester muffler. It is a violation of California Public Resource Code Section 4442 to use or operate the engine on any forest-covered, brush-covered, or grass-covered land without a spark arrester muffler maintained in working order, or the engine constricted, equipped, and maintained for the prevention of fire. Other states or federal areas may have similar laws.

This spark ignition system complies with Canadian ICES-002.

# Introduction

This machine is a ride-on, greens roller intended to be used by professional, hired operators in commercial applications. It is primarily designed for rolling greens, tennis courts, and other fine turf surfaces on well-maintained lawns in parks, golf courses, sports fields, and on commercial grounds.

Read this information carefully to learn how to operate and maintain your product properly and to avoid injury and product damage. You are responsible for operating the product properly and safely.

You may contact Toro directly at [www.Toro.com](http://www.Toro.com) for product and accessory information, help finding a dealer, or to register your product.

Whenever you need service, genuine Toro parts, or additional information, contact an Authorized Service Dealer or Toro Customer Service and have the model and serial numbers of your product ready. [Figure 1](#) identifies the location of the model and serial numbers on the product. Write the numbers in the space provided.

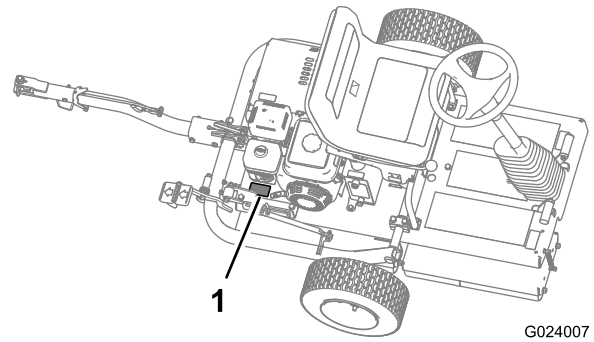

**Figure 1**

1. Location of the model and serial numbers

Model No. \_\_\_\_\_

Serial No. \_\_\_\_\_

This manual identifies potential hazards and has safety messages identified by the safety alert symbol ([Figure 2](#)), which signals a hazard that may cause serious injury or death if you do not follow the recommended precautions.



**Figure 2**

1. Safety alert symbol

This manual uses 2 words to highlight information.

**Important** calls attention to special mechanical information and **Note** emphasizes general information worthy of special attention.

# Contents

Safety .....	4	Brake Maintenance .....	34
Safe Operating Practices .....	4	Checking and Adjusting the Parking Brake .....	34
Toro Safety .....	6	Storage .....	34
Sound Power Level .....	6		
Sound Pressure Level .....	6		
Vibration Level .....	6		
Safety and Instructional Decals .....	7		
Setup .....	11		
1 Installing the Transport Wheels .....	11		
2 Installing the Hitch Assembly .....	12		
3 Replacing the Warning Decal .....	13		
4 Removing the Machine from the Pallet .....	13		
5 Lubricating the Machine .....	14		
Product Overview .....	15		
Controls .....	15		
Engine Controls .....	16		
Specifications .....	17		
Attachments/Accessories .....	17		
Operation .....	17		
Think Safety First .....	17		
Preparing to Use the Machine .....	17		
Checking the Engine-Oil Level .....	17		
Checking the Hydraulic-Fluid Level .....	17		
Checking the Tire Pressure .....	17		
Filling the Fuel Tank .....	18		
Starting and Stopping the Engine .....	19		
Checking the Safety-Interlock System .....	19		
Using the Hitch Lock .....	20		
Transporting the Machine .....	20		
Think Safety First .....	21		
Operating the Machine .....	21		
Operating Tips .....	22		
Maintenance .....	23		
Recommended Maintenance Schedule(s) .....	23		
Notation for Areas of Concern .....	25		
Daily Maintenance Checklist .....	25		
Pre-maintenance Procedures .....	26		
Removing the Cover .....	26		
Lubrication .....	26		
Lubricating the Drive-Roller Bearings and the			
Steering Heads .....	26		
Lubricating the Linkage Pivot Points .....	27		
Lubricating the Drive Chain .....	27		
Engine Maintenance .....	27		
Engine Oil .....	27		
Servicing the Air Cleaner .....	28		
Servicing the Spark Plug .....	29		
Checking and Adjusting the Valve Clearance .....	30		
Fuel System Maintenance .....	30		
Cleaning the Sediment Cup .....	30		
Drive System Maintenance .....	31		
Servicing the Hydraulic Fluid .....	31		
Changing the Hydraulic Fluid and Filter			
.....	32		
Checking and Adjusting the Drive Chain			
Tension .....	33		

# Safety

This machine has been designed in accordance with EN ISO 12100:2010 and ANSI B71.4-2012.

Improperly using or maintaining the machine can result in injury. To reduce the potential for injury, comply with these safety instructions and always pay attention to the safety alert symbol, which means Caution, Warning, or Danger—personal safety instruction. Failure to comply with the instruction may result in personal injury or death.

## Safe Operating Practices

### Training

- Read the *Operator's Manual* and other training material carefully. Be familiar with the controls, safety signs, and the proper use of the machine.
  - If the operator(s) or mechanic(s) cannot read or understand the information it is the owner's responsibility to explain this material to them.
  - All operators and mechanics should be trained. The owner is responsible for training the users.
  - Never allow children or people unfamiliar with these instructions to use or service the machine. Local regulations may restrict the age of the operator.
  - Never operate the machine while people, especially children, or pets are nearby.
  - Keep in mind that the operator or user is responsible for accidents or hazards occurring to other people or their property.
  - The owner/user can prevent and is responsible for accidents or injuries occurring to people or damage to property
  - Do not carry passengers.
  - All drivers should seek and obtain professional and practical instruction. Such instruction should emphasize:
    - The need for care and concentration when working with ride-on machines;
    - Control of a ride-on machine sliding on a slope will not be regained by the application of the transmission pedals.
- The main reasons for loss of control are:
- Insufficient roller grip;
  - Being driven too fast;
  - Inadequate braking;
  - The type of machine is unsuitable for the task;
  - Lack of awareness of the effect of ground conditions, especially slopes
- Watch out for traffic when crossing or near roadways.

### Preparation

- While operating the machine, always wear substantial, slip-resistant footwear, long trousers, hard hat, safety glasses, and ear protection. Long hair, loose clothing, or jewelry may get tangled in moving parts. Do not operate the machine when barefoot or wearing open sandals.
- Thoroughly inspect the area where the machine is to be used, and remove all objects which may be damaged by the machine or which may cause damage to the machine.
- Replace worn or damaged silencers.
- Evaluate the terrain to determine what accessories and attachments are needed to properly and safely perform the job. Only use accessories and attachments approved by the manufacturer.
- Check that all safety shields are attached and functioning properly. Do not operate unless they are functioning properly.

### Operation

- Do not operate the engine in a confined space where dangerous carbon monoxide and other exhaust gasses can collect.
- Operate the machine only in daylight or in good artificial light.
- Stay alert for holes in the terrain and other hidden hazards.
- Avoid operating the machine in wet grass, where feasible.
- Exercise extreme caution when changing direction on slopes.
- Do not use on excessively steep slopes.
- Remember that there is no such thing as a safe slope. Travel on grass slopes requires particular care. To guard against overturning:
  - Do not stop or start suddenly when going up or downhill.
  - Engage the transmission slowly.
  - Stay alert for humps and hollows and other hidden hazards.
- Before dismounting the machine, ensure that it is parked on a level surface and set the parking brake so that it does not roll away.
- Slow down and use extra care on hillsides. Turf conditions can affect the stability of the machine. Use caution while operating near drop-offs.
- Shut off the fuel while storing or transporting the machine. Do not store fuel near flames or drain indoors.
- Park the machine on level ground. Chock the wheels or set the parking brake as required. Never allow untrained personnel to service the machine.
- Use jack stands to support components when required.

- Carefully release pressure from components with stored energy.
- Never allow anyone near the machine while in operation.
- Never operate the machine with damaged guards or without guards in place. Be sure that all guards are functioning properly.
- Do not change the engine governor settings or over speed the engine. Operating the engine at excessive speed may increase the hazard of personal injury.
- Before leaving the operator's position:
  - Stop on level ground.
  - Set the parking brake.
  - Turn the engine speed to idle, and allow it to run for 10 to 20 seconds.
  - Stop the engine.
- Stop the engine:
  - Before fueling;
  - Before checking, cleaning, or working on the machine;
  - After striking a foreign object or if an abnormal vibration occurs. Inspect the machine for damage and make repairs before starting again and operating the machine.
- Reduce the throttle setting before stopping engine and turn the fuel-shutoff valve off at the conclusion of operation.
- Keep hands and feet away from the rollers.
- Do not operate the machine under the influence of alcohol or drugs.
- Lightning can cause severe injury or death. If lightning is seen or thunder is heard in the area, do not operate the machine; seek shelter.
- Use care when loading or unloading the machine into or out of a trailer or a truck.
- Remove equipment from the truck or trailer and refuel it on the ground. If this is not possible, then refuel such equipment with a portable container, rather than from a fuel dispenser nozzle.
- Keep the nozzle in contact with the rim of the fuel tank or container opening at all times until fueling is complete.
- Do not use a nozzle lock open device.
- If fuel is spilled on clothing, change clothing immediately.
- Never overfill fuel tank. Replace fuel cap and tighten securely.

## Maintenance and Storage

- Close the fuel-shutoff valve while storing or transporting the machine. Do not store fuel near flames or drain fuel indoors.
- Park the machine on level ground. Set the parking brake and chock the trailer wheels as required. Never allow untrained personnel to service the machine.
- Use jack stands to support components when required.
- Carefully release pressure from components with stored energy.
- Keep all nuts, bolts, and screws tight to be sure that the machine is in safe working condition. Replace all worn or damaged nuts, bolts, and screws.
- Never store the machine with fuel in the tank inside a building where fumes may reach an open flame or spark.
- Allow the engine to cool before storing the machine in any enclosure, and do not store it near a flame.
- To reduce the risk of fire, keep the engine, silencer, and fuel-storage area free of grass, leaves, or excessive grease.
- Keep all parts in good working condition and all hardware and hydraulic fittings tightened. Replace all worn or damaged parts and decals.
- If the fuel tank has to be drained, do this outdoors.
- Be careful during adjustment of the machine to prevent entrapment of the fingers between moving and fixed parts of the machine.
- Stop the engine and disconnect the spark-plug wire. Wait for all movement to stop before adjusting, cleaning, or repairing.
- Clean grass and debris from rollers, drives, mufflers, and engine to help prevent fires. Clean up oil or fuel spillage.
- Keep hands and feet away from moving parts. If possible, do not make adjustments with the engine running.

## Safe Handling of Fuels

- To avoid personal injury or property damage, use extreme care in handling gasoline. Gasoline is extremely flammable and the vapors are explosive.
- Extinguish all cigarettes, cigars, pipes, and other sources of ignition.
- Use only an approved fuel container.
- Never remove fuel cap or add fuel with the engine running.
- Allow engine to cool before refueling.
- Never refuel the machine indoors.
- Never store the machine or fuel container where there is an open flame, spark, or pilot light such as on a water heater or on other appliances.
- Never fill containers inside a vehicle or on a truck or trailer bed with a plastic liner. Always place containers on the ground away from your vehicle before filling.

## Hauling

- Use care when loading or unloading the machine into a trailer or truck.
- Use full width ramps for loading machine into trailer or truck.
- Tie the machine down securely using straps, chains, cable, or ropes. Both front and rear straps should be directed down and outward from the machine.

## Toro Safety

The following list contains safety information specific to Toro products or other safety information that you must know that is not included in the CE, ISO, or ANSI standard.

Always follow all safety instructions to avoid serious injury or death.

Use of this product for purposes other than the intended use could prove dangerous to user and bystanders.

- The direction on the machine (right or left) is determined from the seated operators position.
- Know how to stop the engine quickly.
- Do not operate the machine while wearing tennis shoes or sneakers.
- Wearing safety shoes and long pants is advisable and required by some local ordinances and insurance regulations.
- Handle gasoline carefully. Wipe up any spills.
- Using the machine demands attention. To prevent loss of control:
  - Do not drive close to sand traps, ditches, creeks, or other hazards.
  - Reduce speed when making sharp turns. Avoid sudden stops and starts.
- Do not touch the engine, muffler, or exhaust pipe while the engine is running or soon after it has stopped because these areas could be hot enough to cause burns.
- When a person or pet appears unexpectedly in or near the work area, stop operation.

## Maintenance and Storage

- Check all fuel lines for tightness and wear on a regular basis. Tighten or repair them as needed.
- If the engine must be running to perform a maintenance adjustment, keep hands, feet, clothing, and any parts of the body away from the rollers, attachments, and any moving parts. Keep everyone away.
- To ensure safety and accuracy, have an Authorized Toro Distributor check the maximum engine speed with a tachometer. The maximum-governed engine speed should be 3600 rpm.
- If major repairs are ever needed or if assistance is desired, contact an Authorized Toro Distributor.
- To ensure optimum performance and continued safety certification of the machine, use only genuine Toro replacement parts and accessories. Replacement parts and accessories made by other manufacturers could be dangerous, and such use could void the product warranty.

## Sound Power Level

This unit has a guaranteed sound power level of 100 dBA, which includes an Uncertainty Value (K) of 2 dBA.

Sound power level was determined according to the procedures outlined in EN ISO 3744.

## Sound Pressure Level

This unit has a sound pressure level at the operator's ear of 87 dBA, which includes an Uncertainty Value (K) of 3 dBA.

Sound pressure level was determined according to the procedures outlined in EN ISO 11201.

Wear hearing protection.

## Vibration Level

### Hand-Arm

Measured vibration level for right hand = 4.3 m/s<sup>2</sup>

Measured vibration level for left hand = 3.4 m/s<sup>2</sup>

Uncertainty Value (K) = 2.1 m/s<sup>2</sup>

Measured values were determined according to the procedures outlined in EN ISO 20643.

# Safety and Instructional Decals



Safety decals and instructions are easily visible to the operator and are located near any area of potential danger. Replace any decal that is damaged or lost.

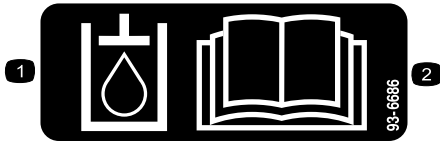

93-6686

1. Hydraulic oil
2. Read the *Operator's Manual*.

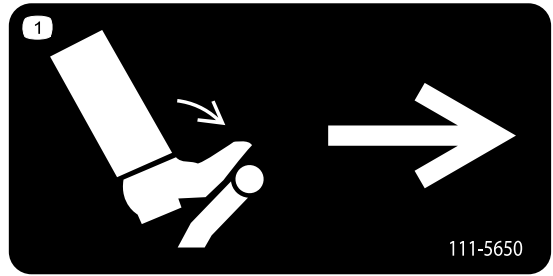

111-5650

1. Traction pedal, push to move right.

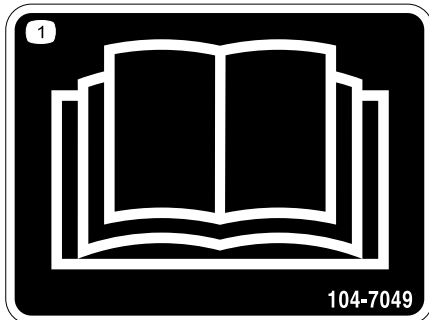

104-7049

1. Read the *Operator's Manual*.



117-2718

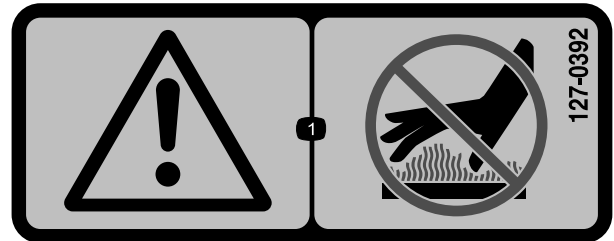

127-0392

1. Warning—keep away from hot surfaces.

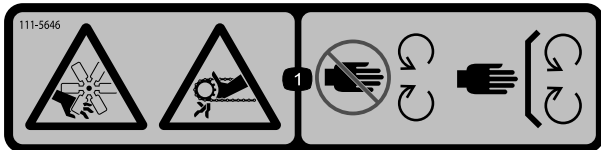

111-5646

1. Cutting/dismemberment hazard, fan; entanglement hazard, belt—keep away from moving parts; keep all guards in place.

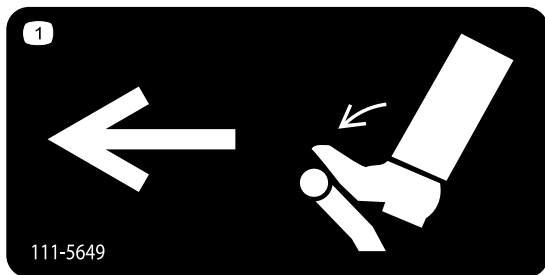

111-5649

1. Traction pedal, push to move left.

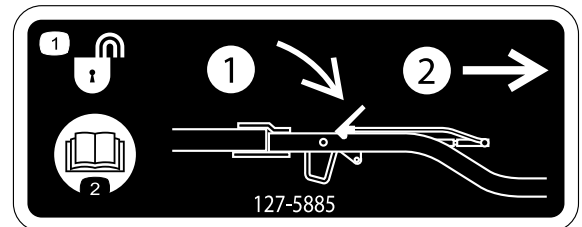

127-5885

1. Hitch unlock—1) push down on the latch; 2) pull out the hitch.
2. Read the *Operator's Manual*.

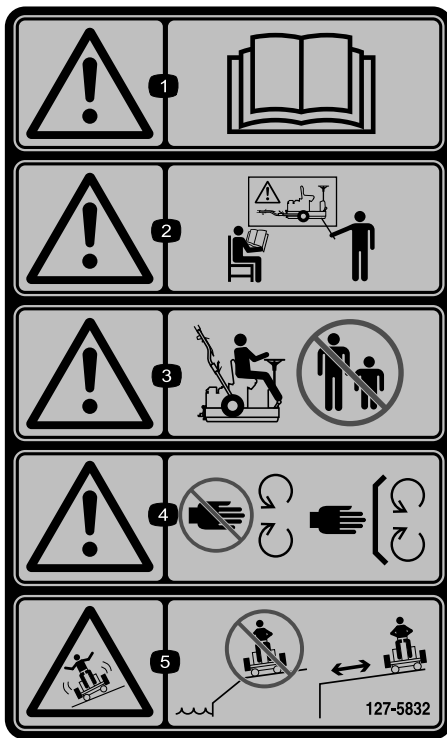

127-5832

1. Warning—read the *Operator's Manual*.
2. Warning—do not operate the machine unless you have received instruction.
3. Warning—keep bystanders away from the machine.
4. Warning—keep hands away from moving parts; keep all guards and safeties in place.
5. Sliding and loss of control hazard—do not operate near drop-offs; use the machine a safe distance from drop-offs.

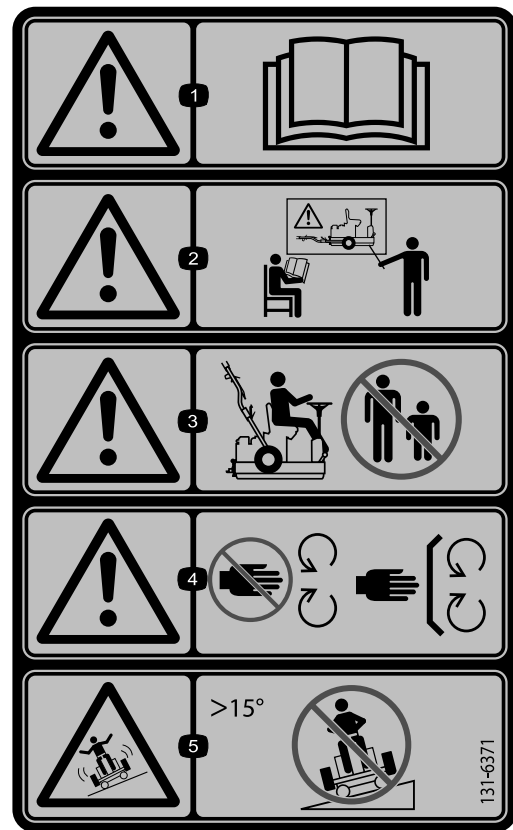

131-6371

CE only

1. Warning—read the *Operator's Manual*.
2. Warning—receive training before operating the machine.
3. Warning—keep bystanders away from the machine.
4. Warning—keep away from moving parts; keep all guards and shields in place.
5. Tipping hazard—do not drive across slopes greater than 15 degrees.

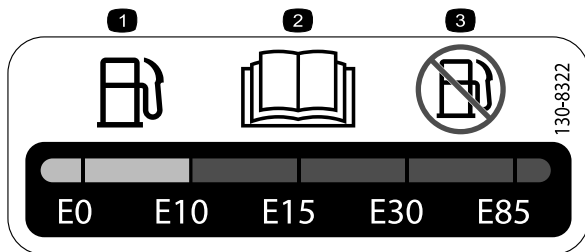

130-8322

1. Only use gasoline that contains 10% ethanol by volume (E10) or less.
2. Read the *Operator's Manual*.
3. Do not use gasoline that contains more than 10% ethanol by volume (E10).

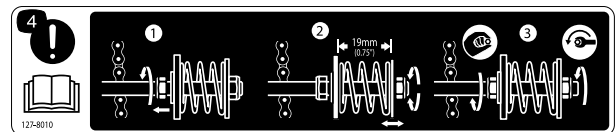

127-8010

1. Loosen the jam nut on the tensioning rod.
2. Adjust the tensioning nut until the distance between the spacer and the fixed bracket is 19 mm (0.75 inches).
3. Hand-tighten the jam nut against the fixed bracket. While holding the jam nut stationary, tighten the tensioning nut to lock the adjustment.
4. Attention—read the *Operator's Manual* for additional adjustment instructions.

# GREENSPRO 1240 QUICK REFERENCE AID

127-5867



SEE OPERATOR'S MANUAL

## CHECK/SERVICE (daily)

1. OIL LEVEL, ENGINE
2. OIL LEVEL, HYDRAULIC TANK
3. AIR CLEANER
4. COOLING FINS
5. GREASE- LUBE POINTS (4)
6. CHAIN TENSION
7. CHAIN LUBRICATION
8. TIRE PRESSURE (10 PSI)

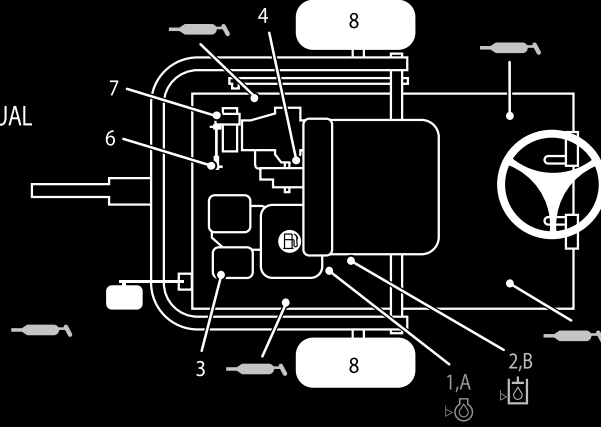

## FLUID SPECIFICATIONS / CHANGE INTERVALS

See operator's manual for initial change	FLUID TYPE	CAPACITY		CHANGE INTERVALS		FILTER PART NO.
		L	QTS.	FLUID	FILTER	
A. ENGINE OIL	SAE 30, SAE 5W30 SAE 10W-30	0.6	0.63	100 HRS.	_____	_____
B. HYDRAULIC OIL	ISO VG 46	2.5	2.64	800 HRS.	800 HRS.	111-5750
C. AIR FILTER	_____	_____	_____	_____	50 HRS.	_____
D. FUEL SEDIMENT CUP	_____	_____	_____	_____	100 HRS.	_____

127-5867

1. Read the *Operator's Manual*.

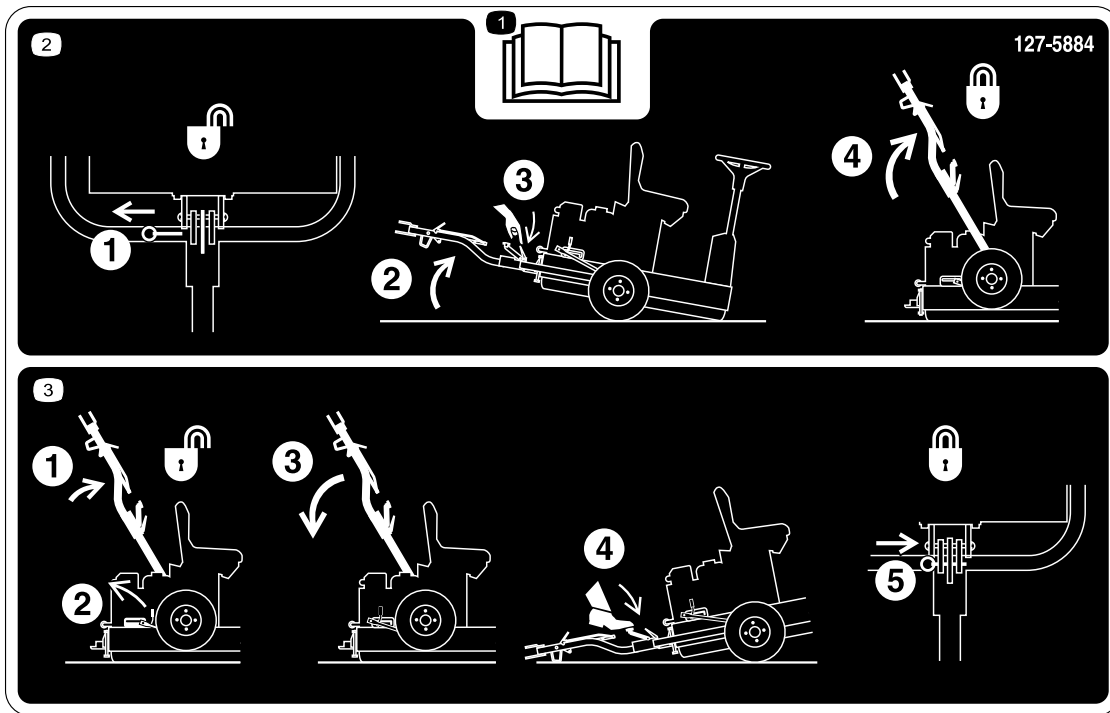

127-5884

1. Read the *Operator's Manual*.
2. 1) Pull the lock pin; 2) Tip the machine up; 3) Unlatch the hitch; 4) Raise the hitch until the lever latch locks in the slide.
3. 1) Push the hitch up; 2) Release the latch lever; 3) Pull the hitch down; 4) Step on the foot pedal until the hitch snaps into place; 5) Insert the lock pin.

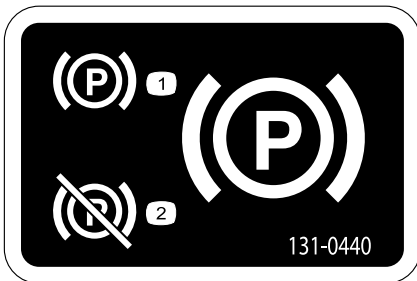

131-0440

1. Parking brake—engage
2. Parking brake—disengage

# Setup

## Loose Parts

Use the chart below to verify that all parts have been shipped.

Procedure	Description	Qty.	Use
<b>1</b>	Transport wheel	2	Install the transport wheels.
<b>2</b>	Hitch assembly Bolt (M10 x 100 mm) Washer (M10) Nut (M10) Bolt (M12 x 100 mm) Washer (M12) Nut (M12) Spacer washer (when applicable)	1 1 2 1 1 2 1 2	Install the hitch assembly.
<b>3</b>	Warning decal	1	Replace the warning decal.
<b>4</b>	No parts required	–	Remove the machine from the pallet.
<b>5</b>	Lubricants (not included)	–	Lubricate the machine.

## Media and Additional Parts

Description	Qty.	Use
Operator's Manual	1	Read the manuals before operating the machine.
Engine owner's manual	1	
Parts catalog	1	Use the catalog to reference part numbers.
Certificate of Compliance	1	The certificate is required for European CE compliance.

# 1

## Installing the Transport Wheels

Parts needed for this procedure:

2	Transport wheel
---	-----------------

## Procedure

1. Remove the lug nuts securing the wheel hubs to the shipping brackets ([Figure 3](#)). Also, remove the nuts threaded onto the stud of each wheel hub.

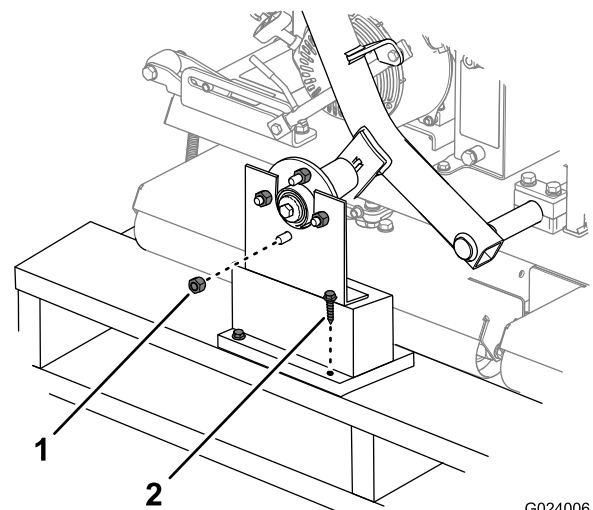

**Figure 3**

G024006

1. Lug nut
2. Shipping bracket

2. Carefully remove the shipping brackets from the crates.

3. Install the transport wheels onto the wheel hubs with the lug nuts. Hand-tighten the lug nuts.

**Note:** The lug nuts will be torqued at the completion of step 2.

4. Adjust the tire pressure to 69 kPa (10 psi).

# 2

## Installing the Hitch Assembly

### Parts needed for this procedure:

1	Hitch assembly
1	Bolt (M10 x 100 mm)
2	Washer (M10)
1	Nut (M10)
1	Bolt (M12 x 100 mm)
2	Washer (M12)
1	Nut (M12)
2	Spacer washer (when applicable)

### Procedure

1. Secure the hitch to the hitch pivot bracket with the appropriate hardware; refer to [Figure 4](#).
  - In the front holes, use a bolt (M10 x 100 mm), 2 washers (M10), and a nut (M10).
  - In the rear holes, use a bolt (M12 x 100 mm), 2 washers (M12), and a nut (M12).
  - If your machine has a 3rd washer included with each bolt, use those washers as spacers between the hitch and the inside of the hitch pivot bracket ([Figure 5](#)).

**Note:** Use the holes in the hitch pivot bracket to match the hitch height of the tow-vehicle hitch.

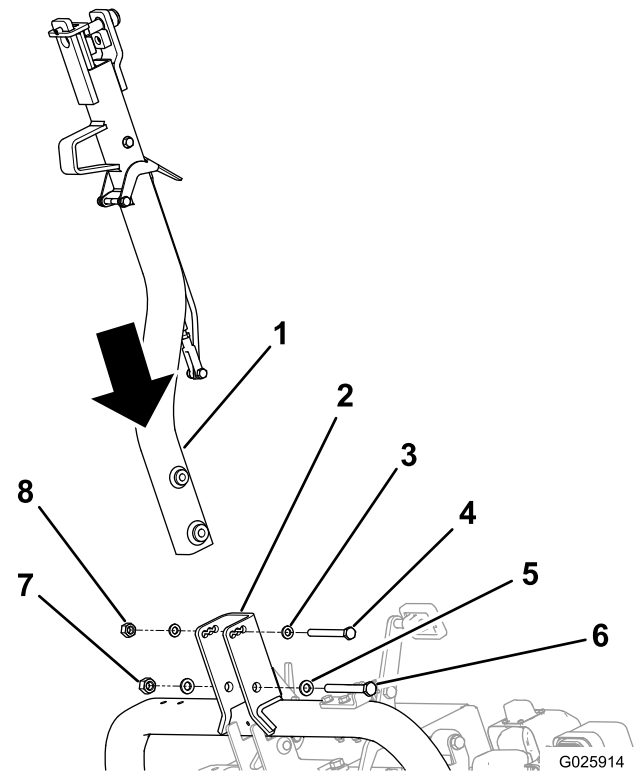

**Figure 4**

- |                        |                    |
|------------------------|--------------------|
| 1. Hitch               | 5. Washer (M12), 2 |
| 2. Hitch pivot bracket | 6. Bolt (M12)      |
| 3. Washer (M10), 2     | 7. Nut (M12)       |
| 4. Bolt (M10)          | 8. Nut (M10)       |

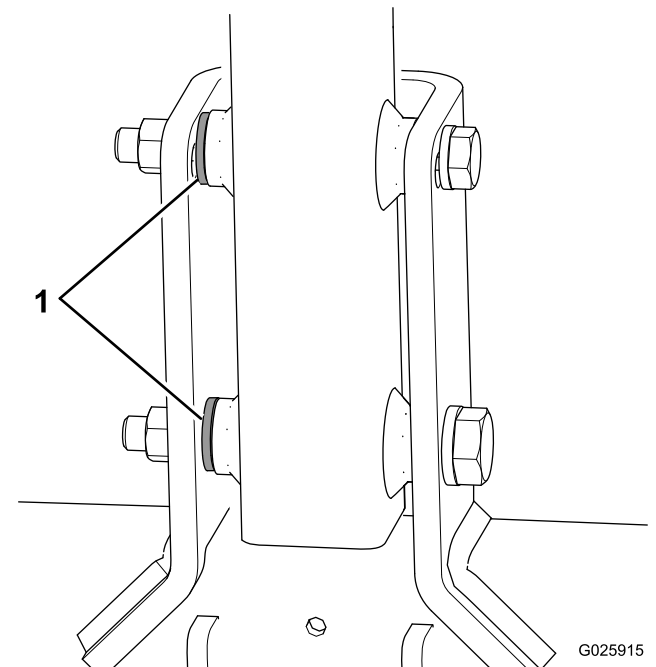
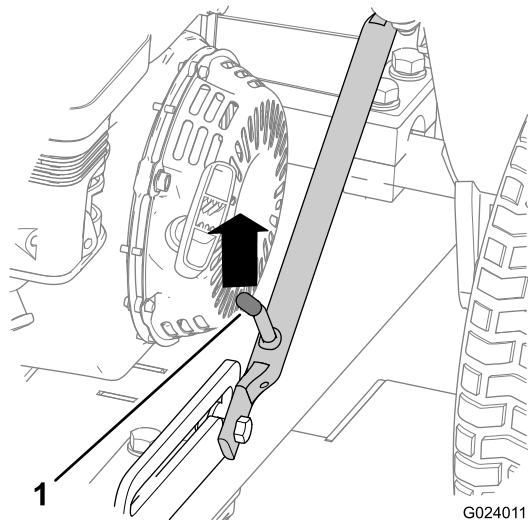

**Figure 5**

1. Spacer washers

2. Tighten the front bolts to 73 N-m (54 ft-lb) and the back bolts to 171 N-m (126 ft-lb).

- Push up on the hitch assembly until the latch lever is unlocked from the slide detent (Figure 6).



**Figure 6**

- Latch lever

- Pull the hitch down.
- Step on the hitch pedal until the hitch locks into place (Figure 7).

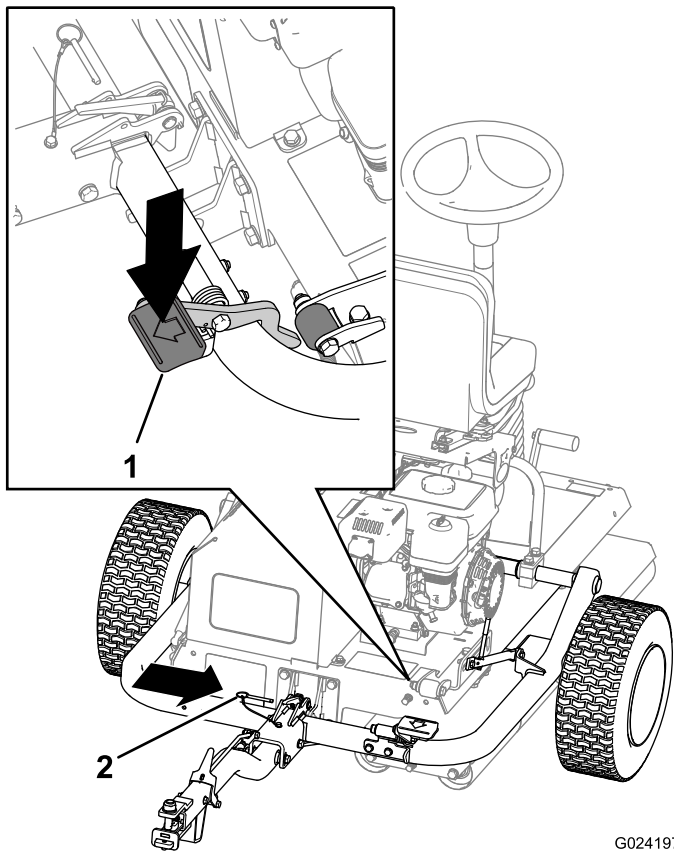

**Figure 7**

- Hitch pedal
- Locking pin

- Insert the locking pin (Figure 7).
- Torque the lug nuts on the transport wheels to 108 N-m (80 ft-lb).

# 3

## Replacing the Warning Decal

Parts needed for this procedure:

1	Warning decal
---	---------------

### Procedure

On machines requiring European CE compliance, replace the warning decal, part number 127-5832 with the warning decal, part number 131-6371.

# 4

## Removing the Machine from the Pallet

No Parts Required

### Procedure

- Remove the wood blocks at the hitch end of the pallet.

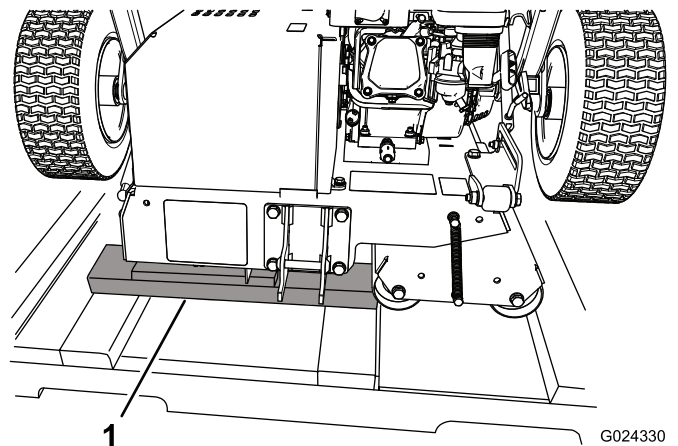

**Figure 8**

- Wood blocks
- Place some wood boards on the ground at the end of the pallet.

**Note:** The height of the wood boards should be slightly lower than the pallet. You can use pieces removed from the sides and/or ends of the crate.

- Carefully roll the machine off the pallet, onto the wood boards, and then to the ground.

**Important:** Ensure that the rollers do not contact the pallet as the machine drops to the ground.

- Remove any remaining packaging.

# 5

## Lubricating the Machine

### Parts needed for this procedure:

-	Lubricants (not included)
---	---------------------------

### Procedure

Before you operate the machine, lubricate it to ensure proper operating characteristics; refer to [Lubrication \(page 26\)](#). Failure to properly lubricate the machine will result in premature failure of critical parts.

# Product Overview

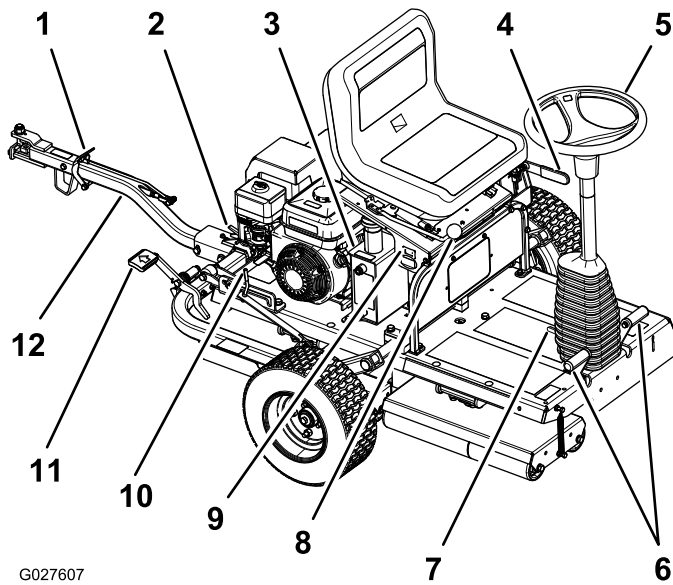

G027607

**Figure 9**

- |                         |                          |
|-------------------------|--------------------------|
| 1. Hitch-lock lever     | 7. Tilt-steering pedal   |
| 2. Hitch latch          | 8. Seat-adjustment lever |
| 3. Hydraulic-fluid tank | 9. Hour meter            |
| 4. Parking brake        | 10. Latch lever          |
| 5. Steering wheel       | 11. Hitch pedal          |
| 6. Motion pedals        | 12. Hitch assembly       |

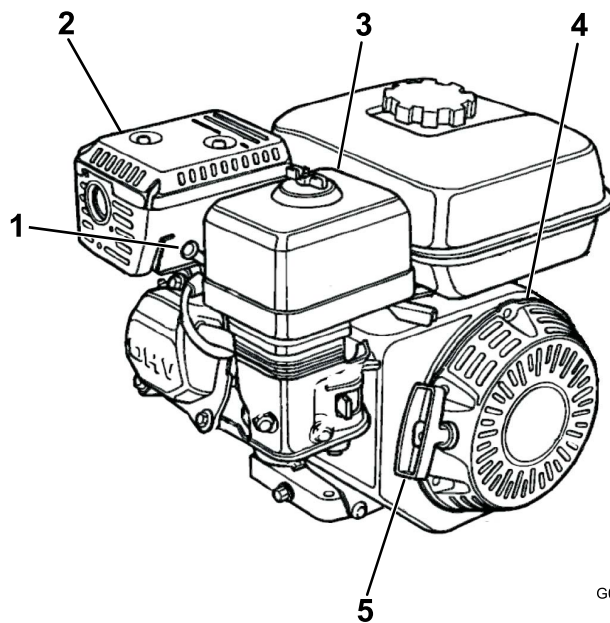

G019903

**Figure 10**

- |                |                        |
|----------------|------------------------|
| 1. Spark plug  | 4. Recoil starter      |
| 2. Muffler     | 5. Recoil-start handle |
| 3. Air cleaner |                        |

## Controls

**Note:** Refer to your engine operator's manual for complete control information.

### Parking Brake

Set the parking brake to allow the machine to start. To set the parking brake (Figure 11), pull back on the parking-brake lever. To release it, push the lever forward.

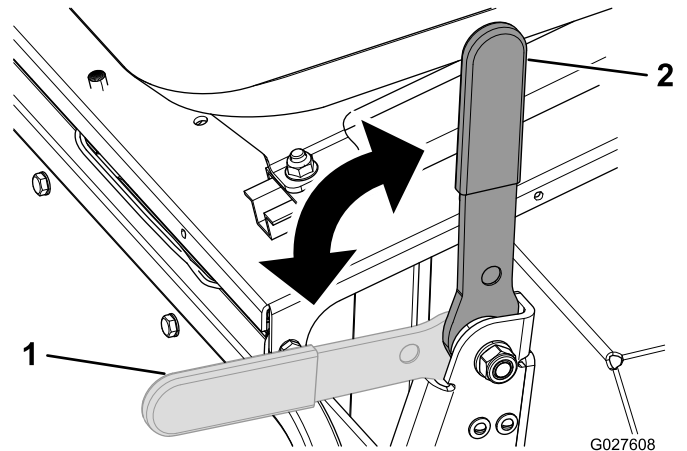

G027608

**Figure 11**

- |                           |                      |
|---------------------------|----------------------|
| 1. Parking brake—released | 2. Parking brake—set |
|---------------------------|----------------------|

### Steering Wheel

Turn the steering wheel (Figure 9) clockwise to turn the machine in the forward direction.

Turn the steering wheel counterclockwise to turn the machine in the rearward direction.

**Note:** As the direction changes at the end of every run, you will need to practice with the machine to become accustomed to the steering.

The steering wheel controls the angle of the smoothing rollers, which in turn steer the machine. The amount the wheel can be turned is limited, so the turning circle of the machine is relatively large.

### Tilt-Steering Pedal

To tilt the steering wheel towards you, press the foot pedal (Figure 9) down, and pull the steering tower toward you to the most comfortable position, and then release the pedal.

### Motion Pedals

The foot-operated motion pedals (Figure 9), located to either side of the base of the steering wheel, control the motion of the drive roller. The pedals are connected so that they cannot both be pressed down at the same time, you can press only 1 pedal at a time. If you press down on the right pedal the machine moves to the right, and if you press down on the left

pedal the machine moves to the left. The further you press a pedal, the faster your speed will be in that direction.

**Note:** When changing machine direction, do not abruptly change pedal direction. Doing so overstresses the traction drive line, resulting in premature failure of drive-line components. Actuate the pedals slowly and smoothly to avoid potential turf scuffing damage as well as drive-line component damage.

When operating the machine on hills, ensure that the drive roller is on the downhill side for adequate traction. Failure to do so may result in turf damage.

## Hitch Assembly

The hitch assembly (Figure 9) is used to tow the machine and to lower/raise the transport wheels.

## Seat-Adjustment Lever

The seat can be moved forward or back to adjust for the height of the operator. Simply move the seat-adjustment lever (Figure 9) to the left and slide the seat forward or back to suit, then release the lever.

## Hour Meter

The hour meter (Figure 9) indicates the total hours of machine operation.

## Engine Controls

### On/Off Switch

The On/Off switch (Figure 12) allows the operator of the machine to start and stop the engine. This switch is located on the front of the engine. Rotate the On/Off switch to the ON position to start and run the engine. Rotate the On/Off switch to the OFF position to stop the engine.

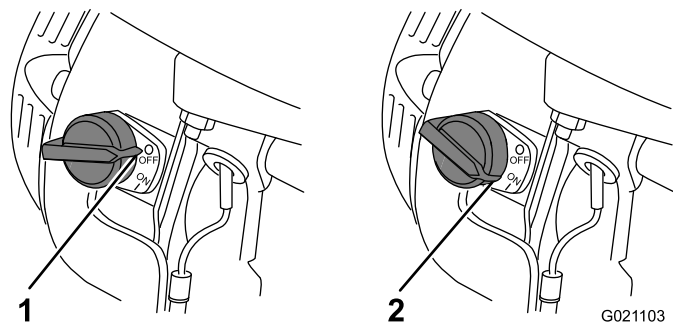

1. OFF position

2. ON position

### Choke Lever

The choke lever (Figure 13) is required when starting a cold engine. Before pulling the recoil-start handle, move the choke

lever to the CLOSED position. Once the engine is running, move the choke lever to the OPEN position. Do not use the choke if the engine is already warmed up or if the air temperature is high.

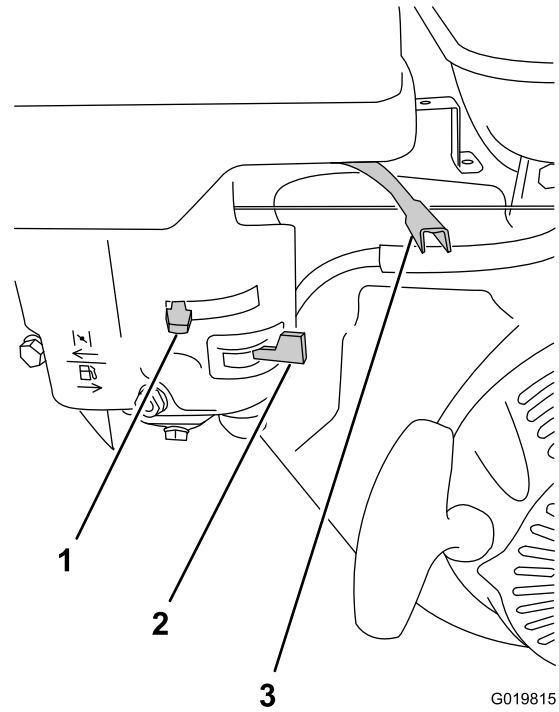

Figure 13

1. Choke lever

2. Fuel-shutoff valve

3. Throttle lever

### Throttle Lever

The throttle lever (Figure 13) is located next to the choke control, and it controls the speed of the engine therefore can increase and decrease the speed of the machine. For best rolling performance, set this control to the FAST position.

### Fuel-Shutoff Valve

The fuel-shutoff valve (Figure 13) is located underneath the choke lever. Move it to the open position before attempting to start the engine. Once you have finished using the machine and you have turned the engine off, move the fuel-shutoff valve to the CLOSED position.

### Recoil-Start Handle

To start the engine, pull the recoil-start handle (Figure 10) quickly to turn the engine over. The controls on the engine described above must all be set correctly for the engine to start.

### Oil-Level Switch

The oil-level switch is located inside the engine; it prevents the engine from running if the oil level falls below the safe operating limit.

## Specifications

Weight	313 kg (691 lb)
Length	136 cm (53.5 inches)
Width	122 cm (48.0 inches)
Height	107 cm (42.2 inches)
Maximum speed	12.8 km/h (8 mph) @ 3600 rpm

## Attachments/Accessories

A selection of Toro approved attachments and accessories is available for use with the machine to enhance and expand its capabilities. Contact your Authorized Service Dealer or Distributor or go to [www.Toro.com](http://www.Toro.com) for a list of all approved attachments and accessories.

To best protect your investment and maintain optimal performance of your Toro equipment, count on Toro genuine parts. When it comes to reliability, Toro delivers replacement parts designed to the exact engineering specification of our equipment. For peace of mind, insist on Toro genuine parts.

## Operation

**Note:** Determine the left and right sides of the machine from the normal operating position.

## Think Safety First

Please carefully read all of the safety instructions and decals in the safety section. Knowing this information could help you or bystanders avoid injury.

### **⚠ DANGER**

**If you operate the machine before reading and understanding this *Operator's Manual*, you or a bystander could be injured.**

**Do not operate the machine until you have completely read this manual.**

## Preparing to Use the Machine

1. Clear any debris from above and underneath the machine.
2. Ensure that any scheduled maintenance has been completed.
3. Ensure that all guards and covers are in place and firmly attached.
4. Check the engine oil level.
5. Ensure that there is gasoline in the fuel tank.
6. Ensure that the parking brake is set.
7. Lift the transport wheels clear of the ground and ensure that they are locked in place.

## Checking the Engine-Oil Level

Check the engine-oil level before each use or daily; refer to [Checking the Engine-Oil Level \(page 27\)](#) in [Maintenance \(page 23\)](#).

## Checking the Hydraulic-Fluid Level

Check the hydraulic-fluid level before each use or daily; refer to [Checking the Hydraulic-Fluid Level \(page 32\)](#) in [Maintenance \(page 23\)](#).

## Checking the Tire Pressure

Make sure that the transport tires are inflated to 69 kPa (10 psi).

# Filling the Fuel Tank

- For best results, use only clean, fresh (less than 30 days old), unleaded gasoline with an octane rating of 87 or higher ((R+M)/2 rating method).
- Ethanol: Gasoline with up to 10% ethanol (gasohol) or 15% MTBE (methyl tertiary butyl ether) by volume is acceptable. Ethanol and MTBE are not the same. Gasoline with 15% ethanol (E15) by volume is not approved for use. **Never use** gasoline that contains more than 10% ethanol by volume, such as E15 (contains 15% ethanol), E20 (contains 20% ethanol), or E85 (contains 85% ethanol). Using unapproved gasoline may cause performance problems and/or engine damage which may not be covered under warranty.
- **Do not** use gasoline containing methanol.
- **Do not** store fuel either in the fuel tank or fuel containers over the winter unless a fuel stabilizer is used
- **Do not** add oil to gasoline.

## **⚠ WARNING**

Gasoline is harmful or fatal if swallowed. Long-term exposure to vapors can cause serious injury and illness.

- Avoid prolonged breathing of vapors.
- Keep face away from nozzle and gas tank or conditioner opening.
- Keep gas away from eyes and skin.

## **⚠ DANGER**

In certain conditions, gasoline is extremely flammable and highly explosive. A fire or explosion from gasoline can burn you and others and can damage property.

- Fill the fuel tank outdoors, in an open area, when the engine is cold. Wipe up any gasoline that spills.
- Do not fill the fuel tank completely full. Add gasoline to the fuel tank until the level is 25 mm (1 inch) below the top of the tank. This empty space in the tank allows the gasoline to expand.
- Never smoke when handling gasoline, and stay away from an open flame or where gasoline fumes may be ignited by a spark.
- Store gasoline in an approved container and keep it out of the reach of children. Do not buy more than a 30-day supply of gasoline.
- Always place gasoline containers on the ground away from your vehicle before filling.
- Do not fill gasoline containers inside a vehicle or on a truck or trailer bed, because interior carpets or plastic truck-bed liners may insulate the container and slow the loss of any static charge.
- When practical, remove gas-powered equipment from the truck or trailer and fuel the equipment with the wheels on the ground. If this is not possible, then fuel such equipment on a truck or trailer from a portable container, rather than from a gasoline dispenser nozzle.
- If a gasoline-dispenser nozzle must be used, keep the nozzle in contact with the rim of the fuel tank or container opening at all times until fueling is complete.

Fuel-Tank Capacity: 3.6 L (0.95 US gallons)

1. Clean around the fuel-tank cap and remove the cap from the tank (Figure 14). Using unleaded (87 pump octane minimum) gasoline, fill the fuel tank to approximately 25 mm (1 inch) below the top of the tank to allow for fuel expansion.

**Important:** Do not overfill the tank. Adding fuel in excess of the prescribed level will result in engine failure due to saturation of the vapor recovery system, resulting in engine performance failure. This is not a warrantable failure and will require replacement of the fuel-tank cap.

**Important:** Never use methanol, gasoline containing methanol, gasohol containing more than 10% ethanol, gasoline additives, premium gasoline, or white gas because the fuel system could be damaged. Do not mix oil with gasoline.

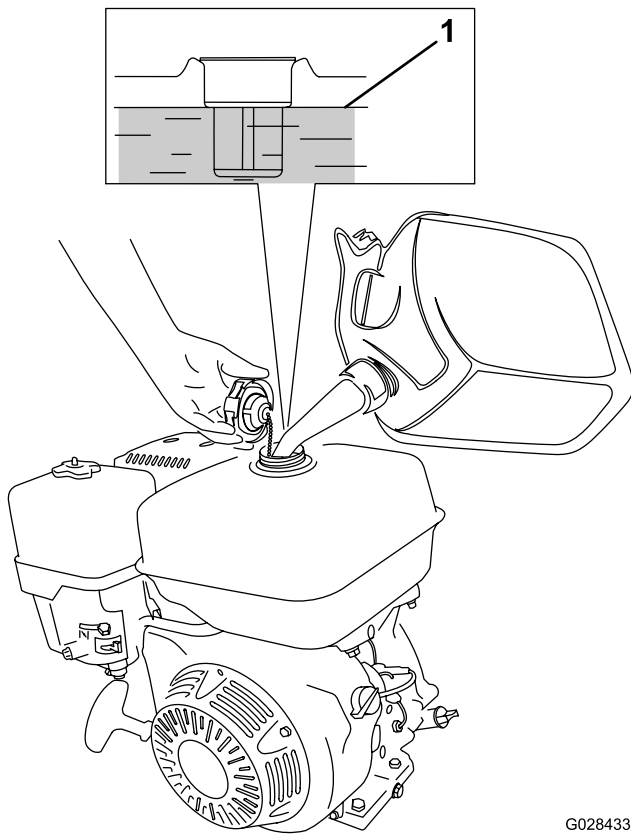

Figure 14

G028433

1. Maximum fuel level
- 
2. Install the fuel-tank cap and wipe up any spilled gasoline.

## Starting and Stopping the Engine

**Note:** For illustrations and descriptions of the controls referenced in this section, refer to [Controls \(page 15\)](#).

### Starting the Engine

**Note:** Make sure that the spark-plug wire is connected to the spark plug.

1. Ensure that the parking brake is set and that the motion pedals are in the NEUTRAL position.
2. Turn the On/Off switch to the ON position.
3. Turn the fuel-shutoff valve to the OPEN position.
4. Move the choke lever to the ON position when starting a cold engine.

**Note:** The choke may not be required when starting a warm engine.

5. Move the throttle control to the Fast position.
6. Stand at the rear of the machine, pull the recoil-start handle out until positive engagement results; then pull it vigorously to start the engine.

**Important:** Do not pull the recoil rope to the limit or let go of the starter handle when the rope is pulled out, because the rope may break or the recoil assembly may be damaged.

7. When the engine has started, push the choke lever to the OFF position.
8. Move the throttle lever to the FAST position, for best roller performance.

### Stopping the Engine

1. After operating the machine, return the motion pedals to the NEUTRAL position and set the parking brake.
2. Turn the engine speed to idle, and allow it to run for 10 to 20 seconds.
3. Turn the On/Off switch to the OFF position.
4. Turn the fuel-shutoff valve to the CLOSED position.

## Checking the Safety-Interlock System

### ⚠ CAUTION

If the safety-interlock switches are disconnected or damaged, the machine could operate unexpectedly, causing personal injury.

- Do not tamper with the interlock switches.
- Check the operation of the interlock switches daily, and replace any damaged switches before operating the machine.

**Important:** If the safety-interlock system does not operate as described below, have an Authorized Toro Distributor repair it immediately.

1. Set the parking brake, ensure that the motion pedals are in the NEUTRAL position, and start the engine.
2. Sit on the seat.
3. With the parking brake set, gently press a motion pedal down; the engine should stop after approximately 1 second.
4. With the engine running and the brake released, stand up and verify that the engine stops after 1 second.

**Note:** The safety-interlock system is also designed to stop the engine if the operator rises off the seat while the machine is moving.

# Using the Hitch Lock

## Connecting the Machine to the Tow Vehicle

Push down on the hitch-lock lever while inserting the hitch assembly onto the tow-vehicle hitch. Release the lever when the hitch and the hitch assembly are aligned (Figure 15).

**Important:** Ensure that the lever returns to the Up position and that the hitch and the hitch assembly are engaged.

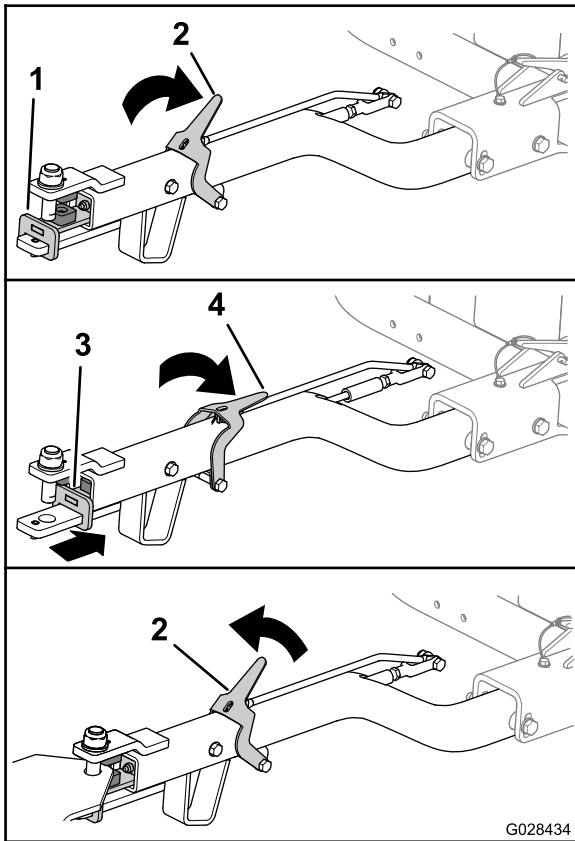

Figure 15

- 1. Hitch assembly (forward)
- 2. Hitch-lock lever (up)
- 3. Hitch assembly (backward)
- 4. Hitch-lock lever (down)

## Disconnecting the Machine from the Tow Vehicle

Push down on the hitch-lock lever while removing the hitch assembly from the tow-vehicle hitch (Figure 15). Release the latch when the hitch and the hitch assembly are disengaged.

# Transporting the Machine

1. Drive the machine to the transport vehicle.
2. Set the parking brake.
3. Move the throttle lever to the low-speed position, and allow the engine to run for 10 to 20 seconds.
4. Turn the On/Off switch to the OFF position.
5. Turn the fuel-shutoff valve to the CLOSED position.
6. Raise the machine onto the transport wheels as follows:
  - A. Push up on the hitch assembly until the latch lever is unlocked from the slide detent (Figure 16).

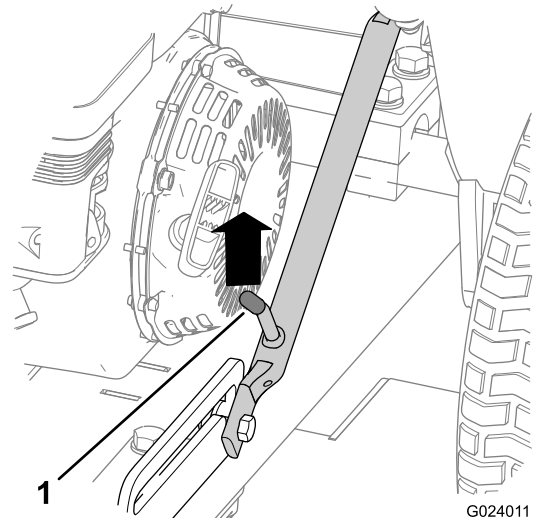

Figure 16

1. Latch lever

- B. Lift the latch lever so that it slides freely, and pull the hitch down.

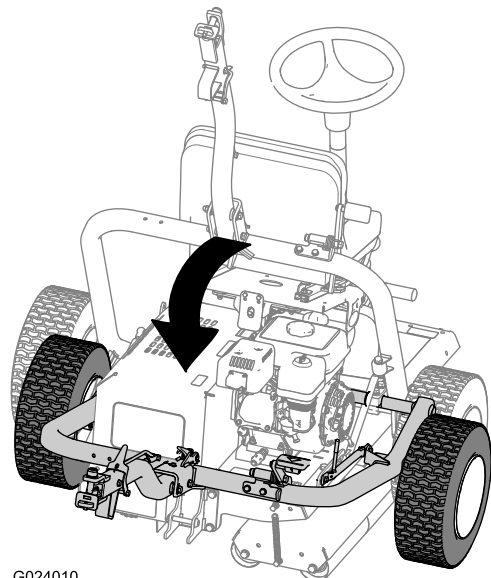
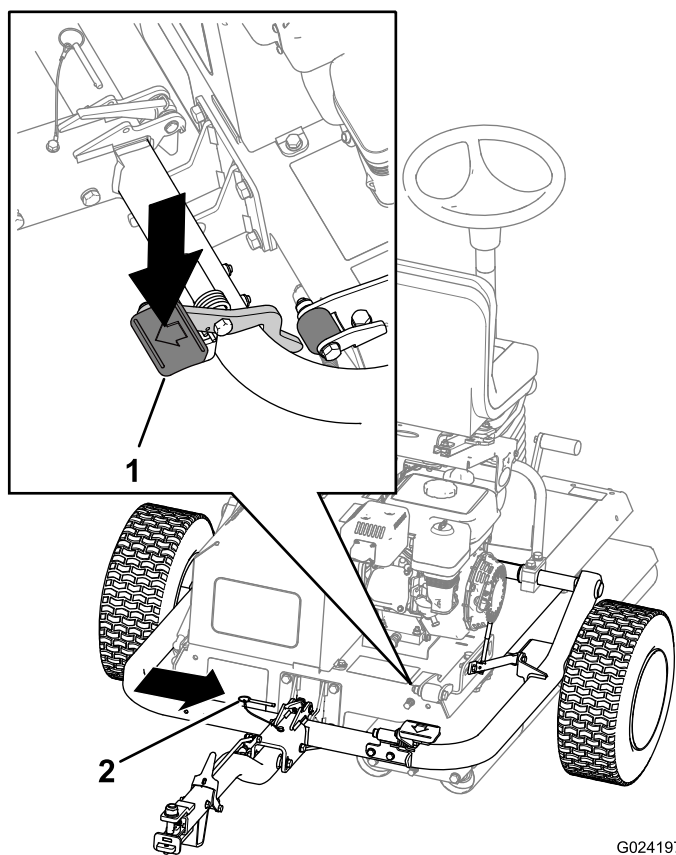

Figure 17

- C. Step on the hitch pedal until the hitch locks into place (Figure 18).

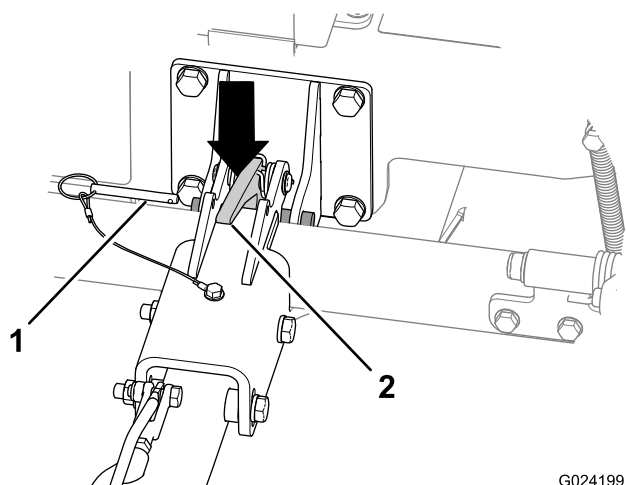

**Figure 18**

G024197

1. Hitch pedal
2. Locking pin

- D. Insert the locking pin (Figure 18).
7. Lower the machine onto the rollers as follows:
  - A. Remove the locking pin (Figure 19).



**Figure 19**

G024199

1. Locking pin
2. Hitch latch

- B. Lift up on the hitch assembly to tip the machine up slightly.
- C. Push down on the hitch latch to unlatch the hitch (Figure 19).

- D. Raise the hitch (Figure 20) until the latch lever locks in the slide detent (Figure 16).

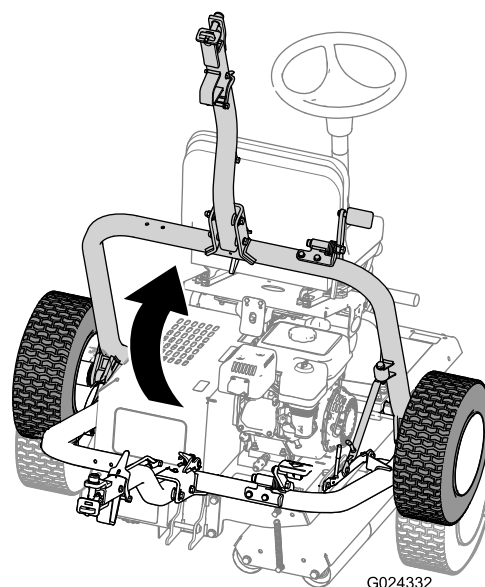

**Figure 20**

G024332

## Think Safety First

Carefully read all safety instructions and symbols in the safety section. Knowing this information could help you or bystanders avoid injury.

### ⚠ CAUTION

**This machine produces sound levels that can cause hearing loss through extended periods of exposure.**

**Wear hearing protection when operating this machine.**

The use of protective equipment for eyes, ears, hands, feet, and head is recommended.

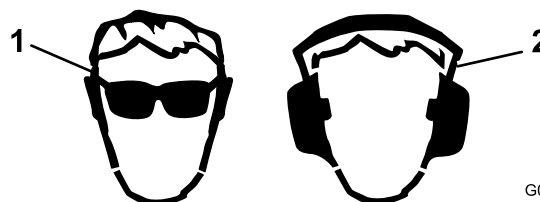

**Figure 21**

G009027

1. Wear safety glasses.
2. Wear hearing protection.

## Operating the Machine

1. Ensure that the parking brake is set.
2. Sit on the operator seat, taking care not to contact the motion pedals as you sit down.
3. Adjust the seat and the steering wheel to a comfortable operating position.

4. Release the parking brake.
5. Hold onto the steering wheel, and slowly press either the left or right motion pedal with your corresponding foot, in whichever direction you wish to move.

**Note:** The further you press the pedal, the faster you will travel in that direction.

6. To stop, release the foot pedal and the machine will stop.

**Note:** As you become familiar with the machine, you will get the feel for when you should release the foot pedal, which will be prior to where you want to finish the run, as the machine will continue to roll for a short time after you release the pedal. As you come to a complete stop, gently press the other foot pedal for your return pass.

**Note:** Do not press the foot pedals too quickly; this will result in possible skidding and scuffing of the turf under the drive roller as well as damage to the drive system. You should always operate the foot pedals in a controlled manner.

7. Turn the steering wheel clockwise to turn the machine in the forward direction.

Turn the steering wheel counterclockwise to turn the machine in the rearward direction.

**Note:** As the direction changes at the end of every run, you will need to practice with the machine to become accustomed to the steering.

**Important:** To stop the machine in an emergency, press the other pedal to the NEUTRAL position. As an example, with the right pedal pressed and traveling to the right, press the left pedal to the NEUTRAL position to bring the machine to a stop. This action must be firm but not sudden, as it may cause the machine to tip sideways.

8. Set the parking brake.
9. Before dismounting the machine, make sure that it is parked on a level surface.

## Operating Tips

- When operating the machine on hills, ensure that the drive roller is on the downhill side for adequate traction. Failure to do so may result in turf damage.
- For the best rolling effect, periodically remove any buildup that accumulates on the rollers.

# Maintenance

## Recommended Maintenance Schedule(s)

Maintenance Service Interval	Maintenance Procedure
After the first 5 hours	<ul style="list-style-type: none"><li>• Check the drive chain tension and adjust it as necessary.</li><li>• Check for any loose nuts, bolts, or fittings and tighten them as required.</li></ul>
After the first 20 hours	<ul style="list-style-type: none"><li>• Change the engine oil.</li><li>• Change the hydraulic fluid and filter.</li></ul>
Before each use or daily	<ul style="list-style-type: none"><li>• Check the safety-interlock system.</li><li>• Lubricate the drive-roller bearings and the bearings in the steering head pivots (lubricate immediately after washing).</li><li>• Lubricate the pivot points.</li><li>• Lubricate the drive chain.</li><li>• Check the engine-oil level.</li><li>• Check the air cleaner.</li><li>• Check the hydraulic-fluid level.</li><li>• Check the drive chain tension and adjust it as necessary.</li><li>• Ensure that the parking brake prevents the machine from rolling when it is parked.</li><li>• Check for any loose nuts, bolts, or fittings and tighten them as required.</li><li>• Check the fuel tank for fuel.</li></ul>
After each use	<ul style="list-style-type: none"><li>• Clear any debris on the roller, especially from around the engine.</li></ul>
Every 50 hours	<ul style="list-style-type: none"><li>• Clean the air cleaner (more often in dirty or dusty conditions).</li><li>• Check for correct tire pressure in the transport wheels.</li></ul>
Every 100 hours	<ul style="list-style-type: none"><li>• Change the engine oil.</li><li>• Check/adjust the spark plug.</li><li>• Clean the sediment cup.</li></ul>
Every 300 hours	<ul style="list-style-type: none"><li>• Replace the paper element.</li><li>• Replace the spark plug.</li><li>• Check and adjust the valve clearance.</li></ul>
Every 800 hours	<ul style="list-style-type: none"><li>• Change the hydraulic fluid and filter.</li></ul>
Before storage	<ul style="list-style-type: none"><li>• Paint chipped surfaces.</li></ul>
Monthly	<ul style="list-style-type: none"><li>• Check for correct tire pressure in the transport wheels.</li></ul>
Yearly	<ul style="list-style-type: none"><li>• Check over the entire machine, including ensuring that all nuts and bolts are tight.</li></ul>

**Important:** Refer to your engine operator's manual for additional maintenance procedures.

## **▲ WARNING**

If you are not careful with hazardous substances, they can cause serious personal injury.

- Read the labels and instructions for the materials that you use.
- Wear the necessary personal protective safety equipment, and use hazardous substances carefully.

The following fluids are identified as being hazardous:

<b>Substances</b>	<b>Assessed Risk</b>
Gasoline	Low
Lubricating oil	Low
Hydraulic fluid	Low
Grease	Low

- When using any of the above fluids it is recommended that eye protection and gloves are worn and that care is taken to prevent spillage.
- Avoid contact with skin; wash off spillage with soap and water.
- Avoid contact with eyes; wash with running water and seek medical attention if symptoms persist.
- Avoid ingestion; if swallowed seek medical attention.
- Keep clear of high-pressure fluid escaping from pinholes, cracked connections, etc. High-pressure fluid can penetrate the skin. Seek immediate medical advice if any fluid is injected into the skin.
- Always use a piece of cardboard or paper when searching for leaks.
- Waste products must not be allowed to contaminate surface water, drains, or sewer systems.

**Important: Prevent environmental damage. Dispose of hazardous substances correctly. When disposing of hazardous waste products, take them to an authorized disposal site.**

# Notation for Areas of Concern

Inspection performed by:		
Item	Date	Information
1		
2		
3		
4		
5		
6		
7		
8		

**Important:** Refer to your engine operator's manual for additional maintenance procedures.

# Daily Maintenance Checklist

Duplicate this page for routine use.

Maintenance Check Item	For the week of:						
	Mon.	Tues.	Wed.	Thurs.	Fri.	Sat.	Sun.
Check that pivot joints operate freely.							
Check the fuel level.							
Check the engine oil level.							
Check the hydraulic fluid level.							
Check the air filter.							
Check the safety interlock system.							
Clean the engine cooling fins.							
Check unusual engine noises.							
Check hoses for damage.							
Check for fluid leaks.							
Lubricate all grease fittings, pivot points and the drive chain							
Check the tire pressure.							
Touch up damaged paint.							

# Premaintenance Procedures

The performance of certain maintenance, adjustments, or repair operations will be determined by the owner's facilities.

Avoid tilting the machine too much. If you tilt the machine, there is a risk that engine oil can enter the cylinder head of the engine, and hydraulic fluid can leak from the cap located on top of the tank. These leaks may result in expensive repairs to the machine; therefore, do not tilt the machine unless it is absolutely necessary. For the purpose of under-deck servicing, lift the machine with a hoist or a small crane.

**Important:** The fasteners on the cover of this machine are designed to remain on the cover after removal. Loosen all the fasteners on the cover so that the cover is loose but still attached, then go back and loosen them until the cover comes free. This will prevent you from accidentally stripping the bolts free of the retainers.

## Removing the Cover

1. Remove the 2 screws securing the cover to the mounting panel.

**Note:** The screws remain on the cover.

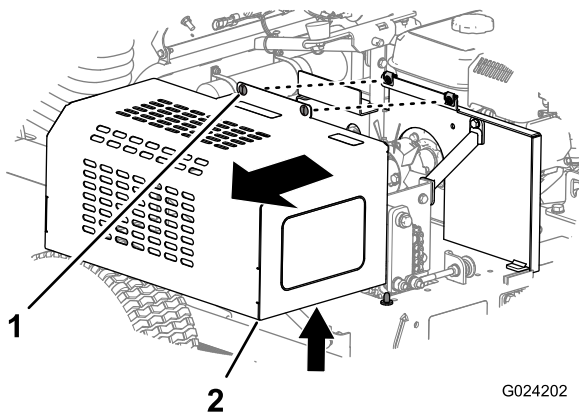

Figure 22

1. Screw (2)
2. Cover

2. Pull the cover upward and away from the mounting panel.

# Lubrication

## Lubricating the Drive-Roller Bearings and the Steering Heads

**Service Interval:** Before each use or daily (lubricate immediately after washing).

**Grease Type:** general-purpose, lithium-based grease

1. Wipe each area clean so that foreign matter cannot be forced into the bearing or bushing.
2. Pump grease into the areas as shown in Figure 23 and Figure 24.

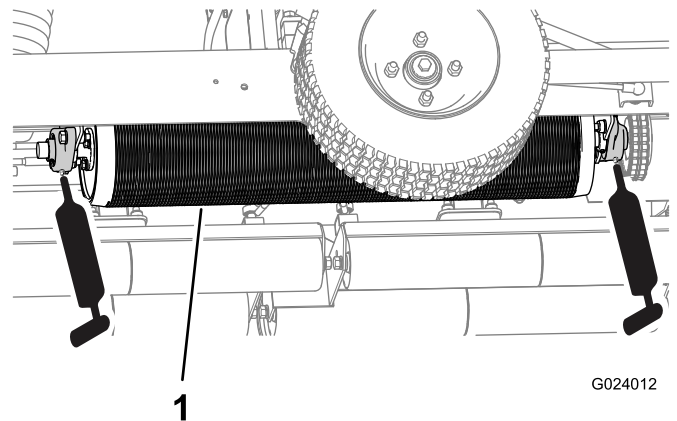

Figure 23

1. Drive roller

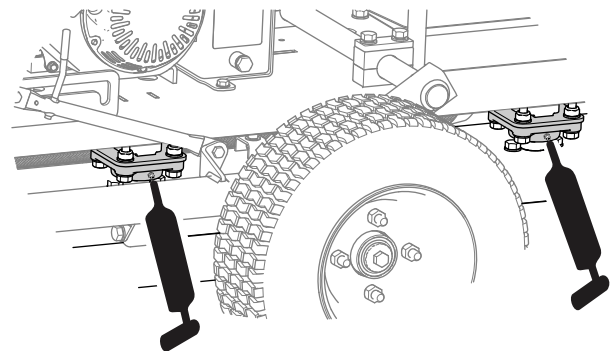

Figure 24

3. Wipe up any excess grease.

**Important:** After greasing, run the machine off the turf somewhere briefly to disperse any excess lubricant, to avoid damaging the turf.

# Lubricating the Linkage Pivot Points

**Service Interval:** Before each use or daily

Apply a few drops of SAE 30 engine oil or spray lubricant to all the pivot points after cleaning the machine.

**Important:** After oiling, run the machine off the turf somewhere briefly to disperse any excess lubricant, to avoid damaging the turf.

# Lubricating the Drive Chain

**Service Interval:** Before each use or daily

**Important:** Every 8 hours of use, or daily (whichever comes first), lightly lubricate the drive chain with Dri Slide® Multi-Purpose lubricant or an equivalent lubricant.

Chains and sprockets are maintenance items and are not covered under the warranty.

# Engine Maintenance

## Engine Oil

**Crankcase Capacity:** 0.60 L (0.63 US qt)

**Type:** API service classification SL, SM, SN, or higher

**Viscosity:** select according to ambient temperature; refer to Figure 25.

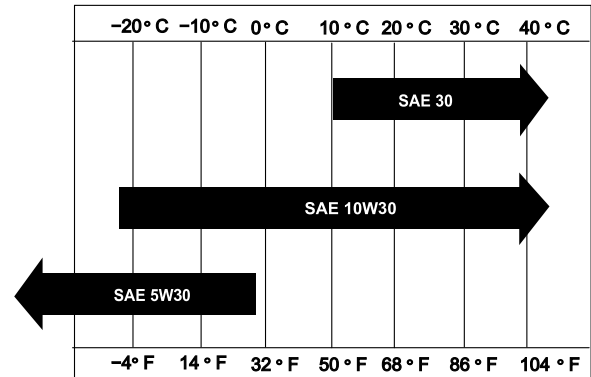

g018667

Figure 25

## Checking the Engine-Oil Level

**Service Interval:** Before each use or daily—Check the engine-oil level.

**Note:** The best time to check the engine oil is when the engine is cool before it has been started for the day. If it has already been run, allow the oil to drain back down to the sump for at least 10 minutes before checking.

1. Position the machine on a flat surface so that the engine is level.
2. Stop the engine, wait for it to cool, and clean the area around the oil filler cap/dipstick (Figure 26).

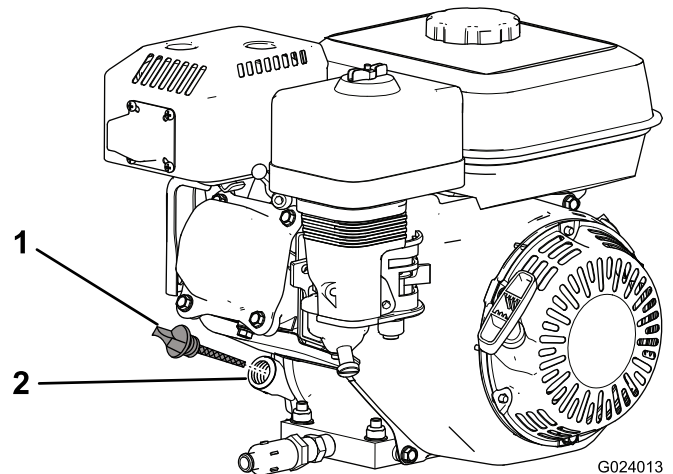

G024013

Figure 26

1. Oil-filler cap/dipstick
2. Filler port

- Remove the oil-filler cap/dipstick by rotating it counterclockwise.
- Wipe the oil-filler cap/dipstick clean and insert it into the filler port.

**Note:** Do not screw the dipstick into the port.

- Remove the dipstick and check the oil level.

**Note:** If the oil level is near or below the lower-limit mark on the dipstick, add only enough oil to raise level to the upper-limit mark (bottom edge of the oil-fill hole); refer to [Figure 27](#). Check the oil level again. Do not overfill the crankcase.

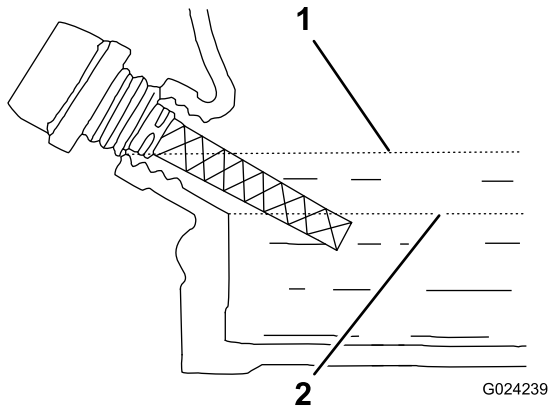

**Figure 27**

- Upper limit
- Lower limit

- Install the oil-filler cap/dipstick and wipe up any spilled oil.

**Note:** Running the engine with the oil level at the lower limit may induce nuisance engine shutdowns in operating situations where the machine is switching direction on an incline or decent.

## Changing the Engine Oil

**Service Interval:** After the first 20 hours—Change the engine oil.

Every 100 hours—Change the engine oil.

- Start and run the engine for a few minutes to warm the engine oil; then stop the engine.
- Raise the machine onto the transport wheels.
- Tilt the machine so that the end of the machine with the engine is closer to the ground, and support the other end to hold it in this position.
- Install the drain hose onto the engine-oil-drain valve ([Figure 28](#)).
- Place the other end of the hose into a suitable container for oil ([Figure 28](#)).

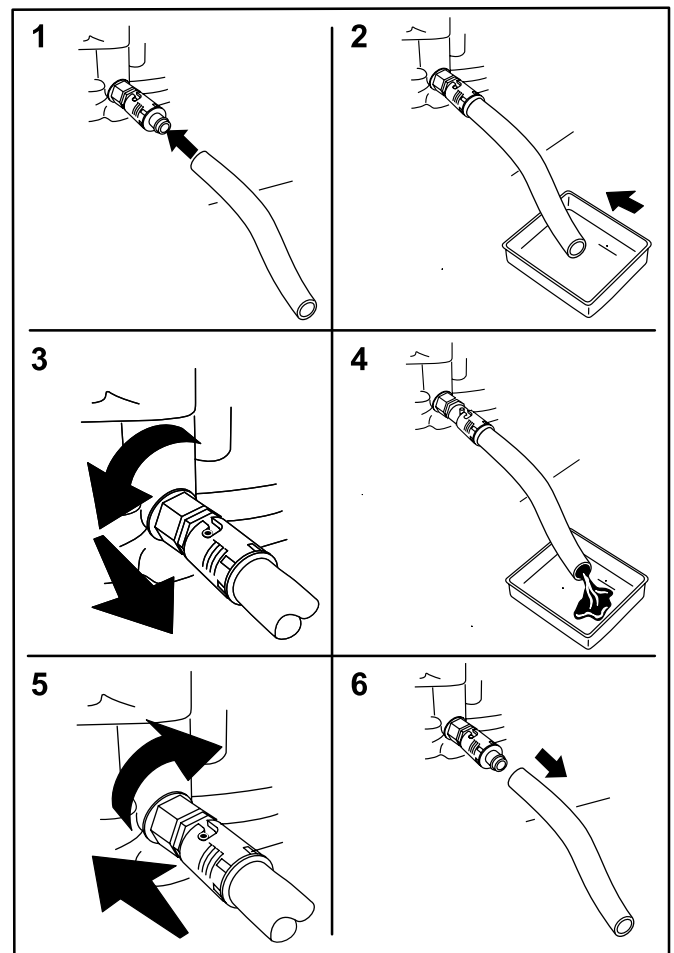

**Figure 28**

- Turn the oil drain valve 1/4 turn counterclockwise to start draining the oil ([Figure 28](#)).
- When all the oil is drained, turn the oil drain valve 1/4 turn clockwise to close the valve ([Figure 28](#)).
- Remove the drain hose and wipe any oil that may have spilled.
- Fill the crankcase with the specified oil; refer to [Engine Oil](#) (page 27).
- Dispose of the oil properly. Recycle it as per local codes.

## Servicing the Air Cleaner

**Service Interval:** Before each use or daily—Check the air cleaner.

Every 50 hours—Clean the air cleaner (more often in dirty or dusty conditions).

Every 300 hours—Replace the paper element.

- Disconnect the spark-plug wire from the spark plug.
- Remove the wing nut securing the air-cleaner cover to the air cleaner, and remove the cover ([Figure 29](#)).

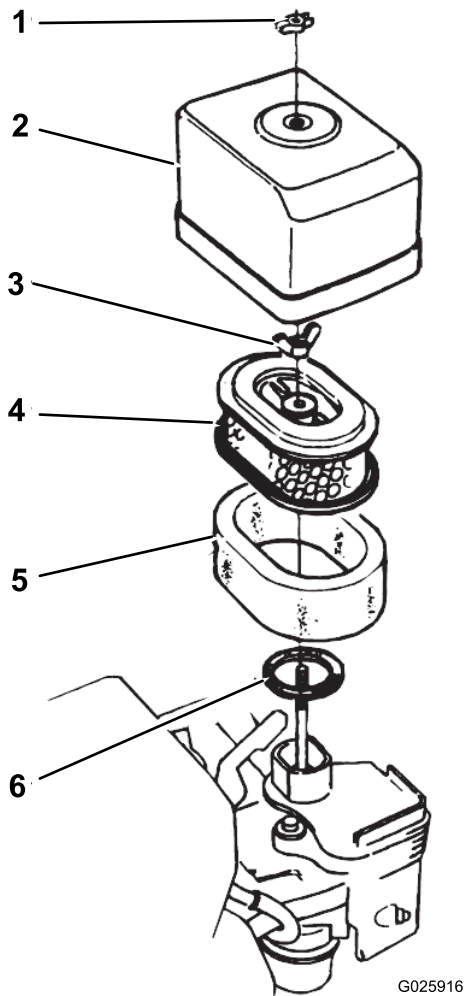

**Figure 29**

- |                      |                  |
|----------------------|------------------|
| 1. Wing nut          | 4. Paper element |
| 2. Air-cleaner cover | 5. Foam element  |
| 3. Wing nut          | 6. Gasket        |

3. Clean the cover thoroughly.
4. Remove the wing nut from the air filter, and remove the filter (Figure 29).
5. Remove the foam filter from the paper filter (Figure 29).
6. Inspect both air-filter elements, and replace them if they are damaged.

**Note:** Always replace the paper air-filter element at the scheduled interval.

7. Clean the foam element as follows:

- A. Wash the foam element in a solution of liquid soap and warm water.

**Note:** Squeeze the element to remove the dirt, but do not twist it, because the foam may tear.

- B. Dry it by wrapping it in a clean rag.

**Note:** Squeeze the rag and foam element to dry the element, but do not twist it, because the foam may tear.

- C. Saturate the element with clean engine oil.

**Note:** Squeeze the element to remove excess oil and to distribute the oil thoroughly. The foam element should be damp with oil.

8. Clean the paper element by tapping the filter element several times on a hard surface to remove the dirt.

**Note:** Never brush dirt off the element or use compressed air to remove dirt; brushing forces dirt into the fibers and compressed air will damage the paper filter.

9. Install the foam element, the paper element, and the air-cleaner cover.

**Important:** Do not operate the engine without the air-cleaner elements, because extreme engine wear and damage will likely result.

## Servicing the Spark Plug

**Service Interval:** Every 100 hours—Check/adjust the spark plug.

Every 300 hours—Replace the spark plug.

**Type:** NGK BPR6ES spark plug or equivalent

**Air Gap:** 0.70 to 0.80 mm (0.028 to 0.031 inch); refer to Figure 31

1. Disconnect the spark-plug wire from the spark plug (Figure 30).

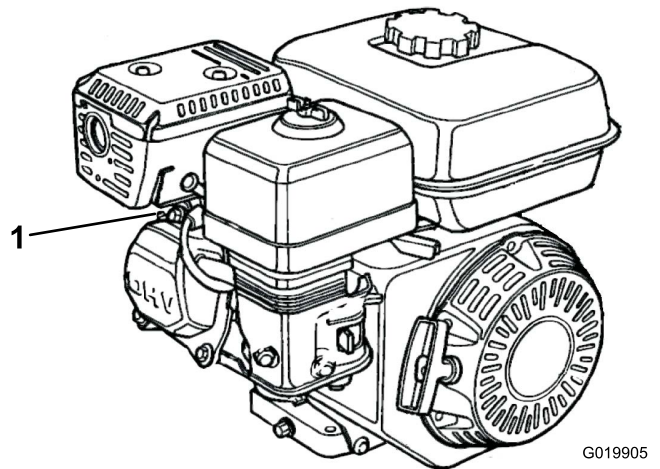

**Figure 30**

1. Spark-plug wire

2. Clean around the spark plug, and remove the plug from the cylinder head.

**Important:** Replace a cracked, fouled, or dirty spark plug. Do not sand blast, scrape, or clean the electrodes, because engine damage could result from grit entering the cylinder.

3. Set the air gap to 0.70 to 0.80 mm (0.028 to 0.031 inch) (Figure 31).

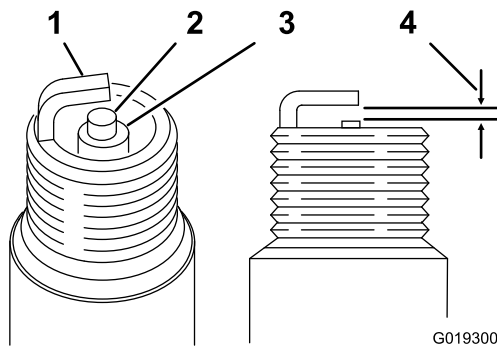

**Figure 31**

- |                     |  |
|---------------------|--|
| 1. Side electrode   | 3. Insulator                             |
| 2. Center electrode | 4. 0.70 to 0.80 mm (0.028 to 0.031 inch) |

- 
4. Install the correctly gapped spark plug carefully by hand, to avoid cross-threading.
  5. After the spark plug is seated, tighten it with a spark-plug wrench to compress the sealing washer.
    - When installing a new spark plug, tighten it 1/2 turn after the spark plug seats, to compress the washer.
    - When installing the original spark plug, tighten it 1/8 to 1/4 turn after the spark plug seats, to compress the washer.

**Note:** A loose spark plug can overheat and damage the engine. Overtightening the spark plug can damage the threads in the cylinder head.

6. Connect the spark-plug wire to the spark plug.

## Checking and Adjusting the Valve Clearance

**Service Interval:** Every 300 hours

**Important:** Refer to your engine operator's manual.

# Fuel System Maintenance

## Cleaning the Sediment Cup

**Service Interval:** Every 100 hours—Clean the sediment cup.

### **⚠ DANGER**

In certain conditions, gasoline is extremely flammable and highly explosive. A fire or explosion from gasoline can burn you and others and can damage property.

- Fill the fuel tank outdoors, in an open area, when the engine is cold. Wipe up any gasoline that spills.
- Do not fill the fuel tank completely full. Add gasoline to the fuel tank until the level is 25 mm (1 inch) below the top of the tank. This empty space in the tank allows the gasoline to expand.
- Never smoke when handling gasoline, and stay away from an open flame or where gasoline fumes may be ignited by a spark.
- Store gasoline in an approved container and keep it out of the reach of children. Do not buy more than a 30-day supply of gasoline.
- Always place gasoline containers on the ground away from your vehicle before filling.
- Do not fill gasoline containers inside a vehicle or on a truck or trailer bed, because interior carpets or plastic truck-bed liners may insulate the container and slow the loss of any static charge.
- When practical, remove gas-powered equipment from the truck or trailer and fuel the equipment with the wheels on the ground. If this is not possible, then fuel such equipment on a truck or trailer from a portable container, rather than from a gasoline dispenser nozzle.
- If a gasoline-dispenser nozzle must be used, keep the nozzle in contact with the rim of the fuel tank or container opening at all times until fueling is complete.

1. Move the fuel valve to the Off position, then remove the fuel sediment cup and O-ring (Figure 32).

# Drive System Maintenance

## Servicing the Hydraulic Fluid

The hydraulic system is filled at the factory with high-quality hydraulic fluid. **Check the level of the hydraulic fluid before the engine is first started and daily thereafter.**

**Note:** Before working on any part of the hydraulic drive system, stop the engine to depressurize the system. Before starting the engine after hydraulic system maintenance, and pressurizing the hydraulic lines, check all hoses and connectors for damage and to ensure that they are tight. Replace any damaged hoses and tighten any loose couplings as required.

Before operating the machine each day, check the level of the hydraulic fluid in the sight glass on the side of the hydraulic-fluid tank.

**Note:** The fluid level should be in the middle of the glass; if it is not, add the appropriate fluid.

**Recommended Hydraulic Fluid: Toro Premium All Season Hydraulic Fluid** (Available in 5 US gallon pails or 55 US gallon drums. Refer to the parts catalog or contact your Authorized Toro Distributor for part numbers.)

Alternative fluids: If the Toro fluid is not available, other **conventional, petroleum-based** fluids may be used, provided they meet all of the following material properties and industry specifications. Check with your oil supplier to see whether the oil meets these specifications.

**Note:** Toro will not assume responsibility for damage caused by improper substitutions, so use only products from reputable manufacturers who will stand behind their recommendation.

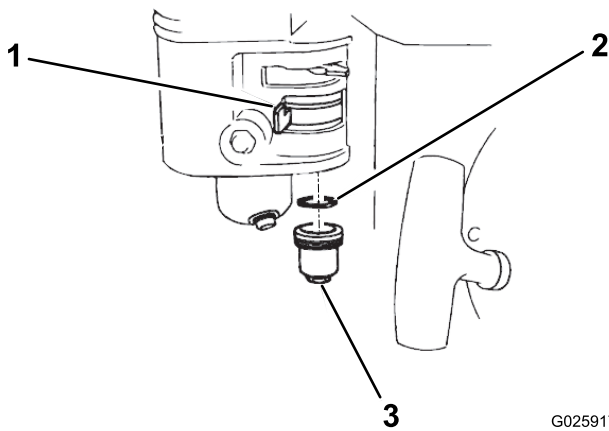

**Figure 32**

G025917

1. Shutoff valve
2. O-ring
3. Sediment cup

2. Wash the sediment cup and O-ring in nonflammable solvent, and dry them thoroughly.
3. Place the O-ring in the fuel valve, and install the sediment cup. Tighten the sediment cup securely.

High Viscosity Index/Low Pour Point Anti-wear Hydraulic Fluid, ISO VG 46 Multigrade	
Material Properties:	
Viscosity, ASTM D445	cSt @ 40°C (104°F) 44 to 48 cSt @ 100°C (212°F) 7.9 to 9.1
Viscosity Index ASTM D2270	140 or higher
Pour Point, ASTM D97	-37°C to -45°C (-34°F to -49°F)
FZG, Fail stage	11 or better
Water content (new fluid):	500 ppm (maximum)
Industry Specifications:	
Vickers I-286-S, Vickers M-2950-S, Denison HF-0, Vickers 35 VQ 25 (Eaton ATS373-C)	

The proper hydraulic fluids must be specified for mobile machinery (as opposed to industrial plant usage), multiweight-type, with ZnDTP or ZDDP anti-wear additive package (not an ashless-type fluid).

**Note:** Many hydraulic fluids are almost colorless, making it difficult to spot leaks. A red dye additive for the hydraulic system fluid is available in 20 ml (2/3 fl oz) bottles. One bottle is sufficient for 15 to 22 L (4 to 6 US gallons) of hydraulic fluid. Order part number 44-2500 from your Authorized Toro Distributor.

## Checking the Hydraulic-Fluid Level

**Service Interval:** Before each use or daily

1. Place the machine on a level surface.
2. Pull back on the seat latch, and tip the seat forward (Figure 33).

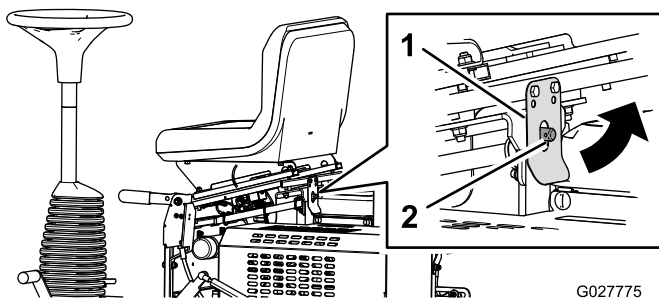

Figure 33

1. Seat latch
2. Latch pin

3. Locate the sight glass (Figure 34) on the side of the hydraulic-fluid tank.

**Note:** When the fluid level is correct, the fluid should be at the middle of the glass.

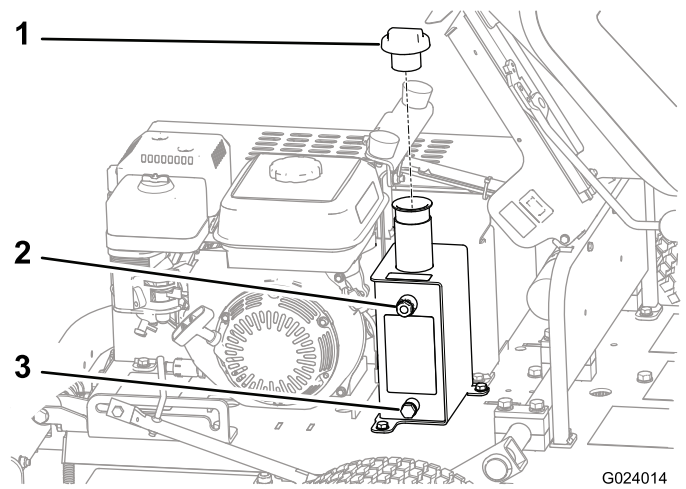

Figure 34

1. Tank cap
2. Sight glass
3. Tank drain

4. If the fluid level is low, remove the cap from the top of the tank (Figure 34), and add enough fluid to raise it to the proper level on the glass.
5. Install the tank cap.
6. Wipe up any spilled fluid.
7. Lower and latch the seat.

## Changing the Hydraulic Fluid and Filter

**Service Interval:** After the first 20 hours—Change the hydraulic fluid and filter.

Every 800 hours/Every 2 years (whichever comes first)—Change the hydraulic fluid and filter.

**Important:** Use only Toro Premium All Season Hydraulic Fluid (ISO VG 46) or an equivalent fluid. Other fluids could cause system damage.

1. Place a drain pan under the hydraulic-tank drain plug (Figure 34).
2. Remove the drain plug from the side of the tank (Figure 34).
3. When the fluid has drained completely, install the drain plug.
4. Clean the area around the filter mounting area.
5. Place a drain pan under the filter and remove the filter (Figure 35).

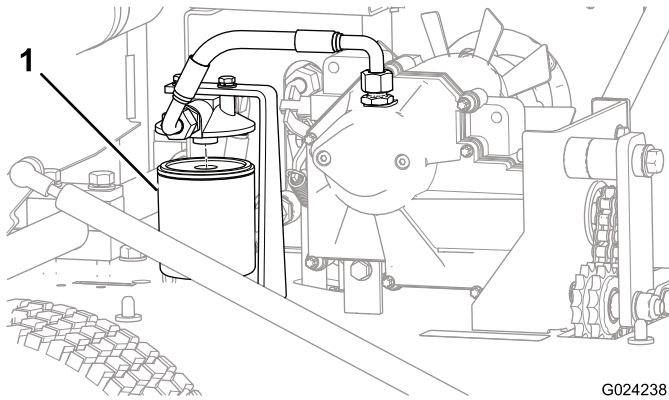

**Figure 35**

G024238

1. Fluid filter

6. Fill the replacement filter with the appropriate hydraulic fluid.
  7. Lubricate the sealing gasket, install the filter by hand until the gasket contacts the filter head, then tighten it 3/4 turn further.
- Note:** The filter should now be sealed.
8. Remove the fluid-tank cap (Figure 34).
  9. Fill the tank with the proper fluid; refer to [Checking the Hydraulic-Fluid Level](#) (page 17).
  10. Install the tank cap.
  11. Wipe up any spilled fluid.
  12. Start the machine and run it at low idle for 3 to 5 minutes to circulate the oil and remove any air trapped in the system.
  13. Stop the engine, check the hydraulic fluid level, and add fluid if necessary.
  14. Lower and latch the seat.
  15. Dispose of the fluid and filter properly. Recycle it according to local codes.

## Checking and Adjusting the Drive Chain Tension

**Service Interval:** After the first 5 hours—Check the drive chain tension and adjust it as necessary.

Before each use or daily—Check the drive chain tension and adjust it as necessary.

**Important:** Chains and sprockets are maintenance items and are not covered under the warranty.

**Drive chain deflection:** 5 to 8 mm (0.200 to 0.300 inch)

**Important:** Check the drive chain tension every 8 hours, or daily (whichever comes first). If you can no longer tension the chain per the deflection specification, replace it. The drive chain is a regular wear item; you need to replace it periodically.

**Note:** The drive chain has stretched (worn) past its useful service life when a direction change of the machine causes the chain to ratchet with proper chain tension, or when the tensioning assembly is properly adjusted, but nevertheless the chain contacts itself.

The drive chain is located under the cover and is tensioned by the idler sprockets, which are mounted to an idler arm. You can tension this arm further if the chain has stretched.

1. Remove the cover and set it aside; refer to [Removing the Cover](#) (page 26).
  2. Set the tension on the drive chain as follows:
    - Loosen the jam nut on the tensioning rod (Figure 36).
    - Loosen or tighten the tensioning nut until the distance between the spacer and the fixed bracket is 19 mm (3/4 inch); refer to Figure 36.
- Note:** The 19 mm (3/4 inch) distance is only measured when the jam nut is loose. The measurement will be less when the tensioning nut is tight.
- Hand-tighten the jam nut against the fixed bracket.
  - While holding the jam nut stationary, tighten the tensioning nut to lock the adjustment.

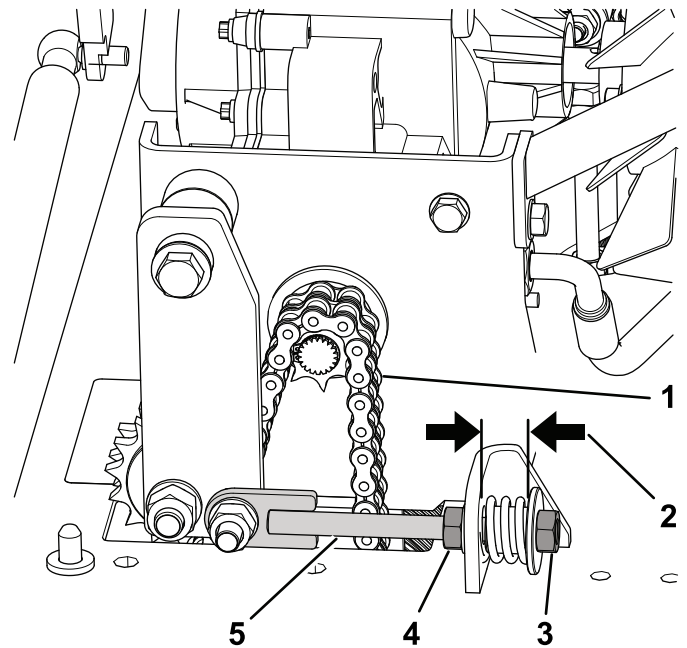

**Figure 36**

G024015

1. Chain
2. 19 mm (3/4 inch) when the jam nut is loose
3. Tensioning nut
4. Jam nut
5. Tensioning rod

3. Install the cover.

# Brake Maintenance

## Checking and Adjusting the Parking Brake

**Service Interval:** Before each use or daily

Ensure that the parking brake prevents the machine from rolling when it is parked.

Adjust the parking brake as follows:

- To increase the brake force, tighten the brake locknut (Figure 37).
- To decrease the brake force, loosen the brake locknut (Figure 37).

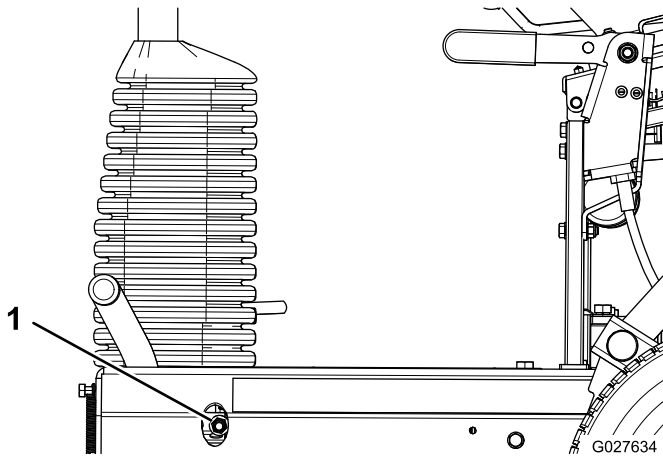

**Figure 37**

1. Brake locknut

**Note:** Ensure that the brake fully releases when the brake handle is in the released position.

# Storage

1. Remove grass clippings, dirt, and grime from the external parts of the entire machine, especially the rollers and the engine. Clean dirt and chaff from the outside of the cylinder-head fins and the blower housing on the engine.

**Important:** You can wash the machine with mild detergent and water. Do not pressure wash the machine. Avoid excessive use of water, especially near the engine.

2. For long-term storage (more than 90 days) add stabilizer/conditioner additive to fuel in the tank.
  - A. Run the engine to distribute the conditioned fuel through the fuel system (5 minutes).
  - B. Either stop the engine, allow it to cool, and drain the fuel tank, or operate the engine until it stops.
  - C. Start the engine and run it until it stops. Repeat the procedure with the choke on, until the engine will not start again.
  - D. Dispose of fuel properly. Recycle it according to local codes.
3. Check and tighten all bolts, nuts, and screws. Repair or replace any part that is worn or damaged.
4. Paint all scratched or bare metal surfaces. Paint is available from your Authorized Service Distributor.
5. Store the machine in a clean, dry garage or storage area. Cover the machine to protect it and keep it clean.

## International Distributor List

<b>Distributor:</b>	<b>Country:</b>	<b>Phone Number:</b>	<b>Distributor:</b>	<b>Country:</b>	<b>Phone Number:</b>
Agrolanc Kft	Hungary	36 27 539 640	Maquiver S.A.	Colombia	57 1 236 4079
Balama Prima Engineering Equip.	Hong Kong	852 2155 2163	Maruyama Mfg. Co. Inc.	Japan	81 3 3252 2285
B-Ray Corporation	Korea	82 32 551 2076	Mountfield a.s.	Czech Republic	420 255 704 220
Casco Sales Company	Puerto Rico	787 788 8383	Mountfield a.s.	Slovakia	420 255 704 220
Ceres S.A.	Costa Rica	506 239 1138	Munditol S.A.	Argentina	54 11 4 821 9999
CSSC Turf Equipment (pvt) Ltd.	Sri Lanka	94 11 2746100	Norma Garden	Russia	7 495 411 61 20
Cyril Johnston & Co.	Northern Ireland	44 2890 813 121	Oslinger Turf Equipment SA	Ecuador	593 4 239 6970
Cyril Johnston & Co.	Republic of Ireland	44 2890 813 121	Oy Hako Ground and Garden Ab	Finland	358 987 00733
Equiver	Mexico	52 55 539 95444	Parkland Products Ltd.	New Zealand	64 3 34 93760
Femco S.A.	Guatemala	502 442 3277	Perfetto	Poland	48 61 8 208 416
ForGarder OU	Estonia	372 384 6060	Pratoverde SRL.	Italy	39 049 9128 128
G.Y.K. Company Ltd.	Japan	81 726 325 861	Prochaska & Cie	Austria	43 1 278 5100
Geomechaniki of Athens	Greece	30 10 935 0054	RT Cohen 2004 Ltd.	Israel	972 986 17979
Golf international Turizm	Turkey	90 216 336 5993	Riversa	Spain	34 9 52 83 7500
Guandong Golden Star	China	86 20 876 51338	Lely Turfcare	Denmark	45 66 109 200
Hako Ground and Garden	Sweden	46 35 10 0000	Solvart S.A.S.	France	33 1 30 81 77 00
Hako Ground and Garden	Norway	47 22 90 7760	Spypros Stavrinides Limited	Cyprus	357 22 434131
Hayter Limited (U.K.)	United Kingdom	44 1279 723 444	Surge Systems India Limited	India	91 1 292299901
Hydroturf Int. Co Dubai	United Arab Emirates	97 14 347 9479	T-Markt Logistics Ltd.	Hungary	36 26 525 500
Hydroturf Egypt LLC	Egypt	202 519 4308	Toro Australia	Australia	61 3 9580 7355
Irrimac	Portugal	351 21 238 8260	Toro Europe NV	Belgium	32 14 562 960
Irrigation Products Int'l Pvt Ltd.	India	0091 44 2449 4387	Valtech	Morocco	212 5 3766 3636
Jean Heybroek b.v.	Netherlands	31 30 639 4611	Victus Emak	Poland	48 61 823 8369

### European Privacy Notice

#### The Information Toro Collects

Toro Warranty Company (Toro) respects your privacy. In order to process your warranty claim and contact you in the event of a product recall, we ask you to share certain personal information with us, either directly or through your local Toro company or dealer.

The Toro warranty system is hosted on servers located within the United States where privacy law may not provide the same protection as applies in your country.

**BY SHARING YOUR PERSONAL INFORMATION WITH US, YOU ARE CONSENTING TO THE PROCESSING OF YOUR PERSONAL INFORMATION AS DESCRIBED IN THIS PRIVACY NOTICE.**

#### The Way Toro Uses Information

Toro may use your personal information to process warranty claims, to contact you in the event of a product recall and for any other purpose which we tell you about. Toro may share your information with Toro's affiliates, dealers or other business partners in connection with any of these activities. We will not sell your personal information to any other company. We reserve the right to disclose personal information in order to comply with applicable laws and with requests by the appropriate authorities, to operate our systems properly or for our own protection or that of other users.

#### Retention of your Personal Information

We will keep your personal information as long as we need it for the purposes for which it was originally collected or for other legitimate purposes (such as regulatory compliance), or as required by applicable law.

#### Toro's Commitment to Security of Your Personal Information

We take reasonable precautions in order to protect the security of your personal information. We also take steps to maintain the accuracy and current status of personal information.

#### Access and Correction of your Personal Information

If you would like to review or correct your personal information, please contact us by email at [legal@toro.com](mailto:legal@toro.com).

### Australian Consumer Law

Australian customers will find details relating to the Australian Consumer Law either inside the box or at your local Toro Dealer.



# The Toro Total Coverage Guarantee

## A Limited Warranty

### Conditions and Products Covered

The Toro® Company and its affiliate, Toro Warranty Company, pursuant to an agreement between them, jointly warrant your Toro Commercial product ("Product") to be free from defects in materials or workmanship for two years or 1500 operational hours\*, whichever occurs first. This warranty is applicable to all products with the exception of Aerators (refer to separate warranty statements for these products). Where a warrantable condition exists, we will repair the Product at no cost to you including diagnostics, labor, parts, and transportation. This warranty begins on the date the Product is delivered to the original retail purchaser.

\* Product equipped with an hour meter.

### Instructions for Obtaining Warranty Service

You are responsible for notifying the Commercial Products Distributor or Authorized Commercial Products Dealer from whom you purchased the Product as soon as you believe a warrantable condition exists. If you need help locating a Commercial Products Distributor or Authorized Dealer, or if you have questions regarding your warranty rights or responsibilities, you may contact us at:

Commercial Products Service Department  
Toro Warranty Company  
8111 Lyndale Avenue South  
Bloomington, MN 55420-1196  
E-mail: commercial.warranty@toro.com

### Owner Responsibilities

As the Product owner, you are responsible for required maintenance and adjustments stated in your Operator's Manual. Failure to perform required maintenance and adjustments can be grounds for disallowing a warranty claim.

### Items and Conditions Not Covered

Not all product failures or malfunctions that occur during the warranty period are defects in materials or workmanship. This warranty does not cover the following:

- Product failures which result from the use of non-Toro replacement parts, or from installation and use of add-on, or modified non-Toro branded accessories and products. A separate warranty may be provided by the manufacturer of these items.
- Product failures which result from failure to perform recommended maintenance and/or adjustments. Failure to properly maintain your Toro product per the Recommended Maintenance listed in the *Operator's Manual* can result in claims for warranty being denied.
- Product failures which result from operating the Product in an abusive, negligent or reckless manner.
- Parts subject to consumption through use unless found to be defective. Examples of parts which are consumed, or used up, during normal Product operation include, but are not limited to, brakes pads and linings, clutch linings, blades, reels, bed knives, tines, spark plugs, castor wheels, tires, filters, belts, and certain sprayer components such as diaphragms, nozzles, and check valves, etc.
- Failures caused by outside influence. Items considered to be outside influence include, but are not limited to, weather, storage practices,

contamination, use of unapproved coolants, lubricants, additives, fertilizers, water, or chemicals, etc.

- Normal noise, vibration, wear and tear, and deterioration.
- Normal "wear and tear" includes, but is not limited to, damage to seats due to wear or abrasion, worn painted surfaces, scratched decals or windows, etc.

### Parts

Parts scheduled for replacement as required maintenance are warranted for the period of time up to the scheduled replacement time for that part. Parts replaced under this warranty are covered for the duration of the original product warranty and become the property of Toro. Toro will make the final decision whether to repair any existing part or assembly or replace it. Toro may use remanufactured parts for warranty repairs.

### Note Regarding Deep Cycle Battery Warranty:

Deep cycle batteries have a specified total number of kilowatt-hours they can deliver during their lifetime. Operating, recharging, and maintenance techniques can extend or reduce total battery life. As the batteries in this product are consumed, the amount of useful work between charging intervals will slowly decrease until the battery is completely worn out. Replacement of worn out batteries, due to normal consumption, is the responsibility of the product owner. Battery replacement may be required during the normal product warranty period at owner's expense.

### Maintenance is at Owner's Expense

Engine tune-up, lubrication cleaning and polishing, replacement of Items and Conditions Not Covered filters, coolant, and completing Recommended Maintenance are some of the normal services Toro products require that are at the owner's expense.

### General Conditions

Repair by an Authorized Toro Distributor or Dealer is your sole remedy under this warranty.

**Neither The Toro Company nor Toro Warranty Company is liable for indirect, incidental or consequential damages in connection with the use of the Toro Products covered by this warranty, including any cost or expense of providing substitute equipment or service during reasonable periods of malfunction or non-use pending completion of repairs under this warranty. Except for the Emissions warranty referenced below, if applicable, there is no other express warranty.**

All implied warranties of merchantability and fitness for use are limited to the duration of this express warranty. Some states do not allow exclusions of incidental or consequential damages, or limitations on how long an implied warranty lasts, so the above exclusions and limitations may not apply to you.

This warranty gives you specific legal rights, and you may also have other rights which vary from state to state.

### Countries Other than the United States or Canada

Customers should contact their Toro Distributor (Dealer) to obtain guarantee policies for your country, province, or state. If for any reason you are dissatisfied with your Distributor's service or have difficulty obtaining guarantee information, contact the Toro importer. If all other remedies fail, you may contact us at Toro Warranty Company.