



Count on it.

Parts Catalog

CM-1258Y-SD

Concrete Mixer

Model No. 68011—Serial No. 316000001 and Up



Ordering Replacement Parts

To order replacement parts, please supply the part number, the quantity, and the description of each part desired.

Understanding Reference Numbers

Each identified part in an illustration has a reference number. The reference number for a part also appears in the parts list, along with other information about the part.

This catalog uses two special reference number formats, one to indicate parts in a service assembly and another to indicate the quantity of a given part in an illustration.

Service Assembly Reference Numbers

Parts in service assemblies have reference numbers in the form a:b. The a represents the reference number of the entire service assembly and the b represents a sequential number unique to each part within the service assembly.

For example, a wheel assembly might be identified by reference number 6, the tire by 6:1, the valve by 6:2, and the wheel by 6:3. When you order the assembly identified by reference number 6, you receive all parts identified by reference numbers 6:1, 6:2, and 6:3. However, you may also order any part individually. Reference numbers of this type appear in illustration and in parts lists.

Reference Numbers Indicating Quantity

In an illustration, if a reference number indicates more than one part, the reference number has the form nX y. The n represents the quantity of the part, the X is the multiplication symbol, and the y represents the reference number.

For example, in an illustration, the reference number 2X 37 means that two of the parts identified by reference number 37 are indicated.

List of Abbreviations

AR: as required

ASM: assembly

BBC: blade brake control

BHTF: button head thread forming

CARR: carriage

CCW: counter clockwise

CW: clockwise

DEG: degrees

DPA: Dual Point Adjustment

ECM: electronic control module

EXT: external

FH: flat head

GA: gauge

HD: heavy-duty

HF: hex flange

HH: hex head

HHF: hex head flange

HHFTF: hex head flange thread forming

HJ: hex jam

HLH: hex lag head

HOC: height-of-cut

HP: high pressure

HSBH: hex socket button head

HSFH: hex socket flat head

HSH: hex socket head

HWH: hex washer head

HWHTF: hex washer head thread forming

HYD: hydraulic

LH: left hand

LP: low pressure

LPG: Liquefied Petroleum Gas

NI: nylon insert

NPTF: national pipe thread fine

PFH: phillips flat head

PPH: phillips pan head

PPHTF: phillips pan head thread forming

PRH: phillips round head

PTH: phillips truss head

PTO: power-take-off

RH: right hand

ROPS: roll-over protection system

RRB: rear roller brush

SFH: slotted fillister head

SHH: slotted hex head

SHWH: slotted hex washer head

SPH: slotted pan head

SQH: square head

SRH: slotted round head

STD: standard

TAP: self tapping

TTH: torx truss head

Contents

- Frame Assembly..... 4
- Axle Assembly 6
- Hub Assembly No. 125-8171 8
- Engine and Drive Assembly 10
- Drum Assembly 12
- Cowl Assembly 14
- Attachments and Accessories 16

Frame Assembly

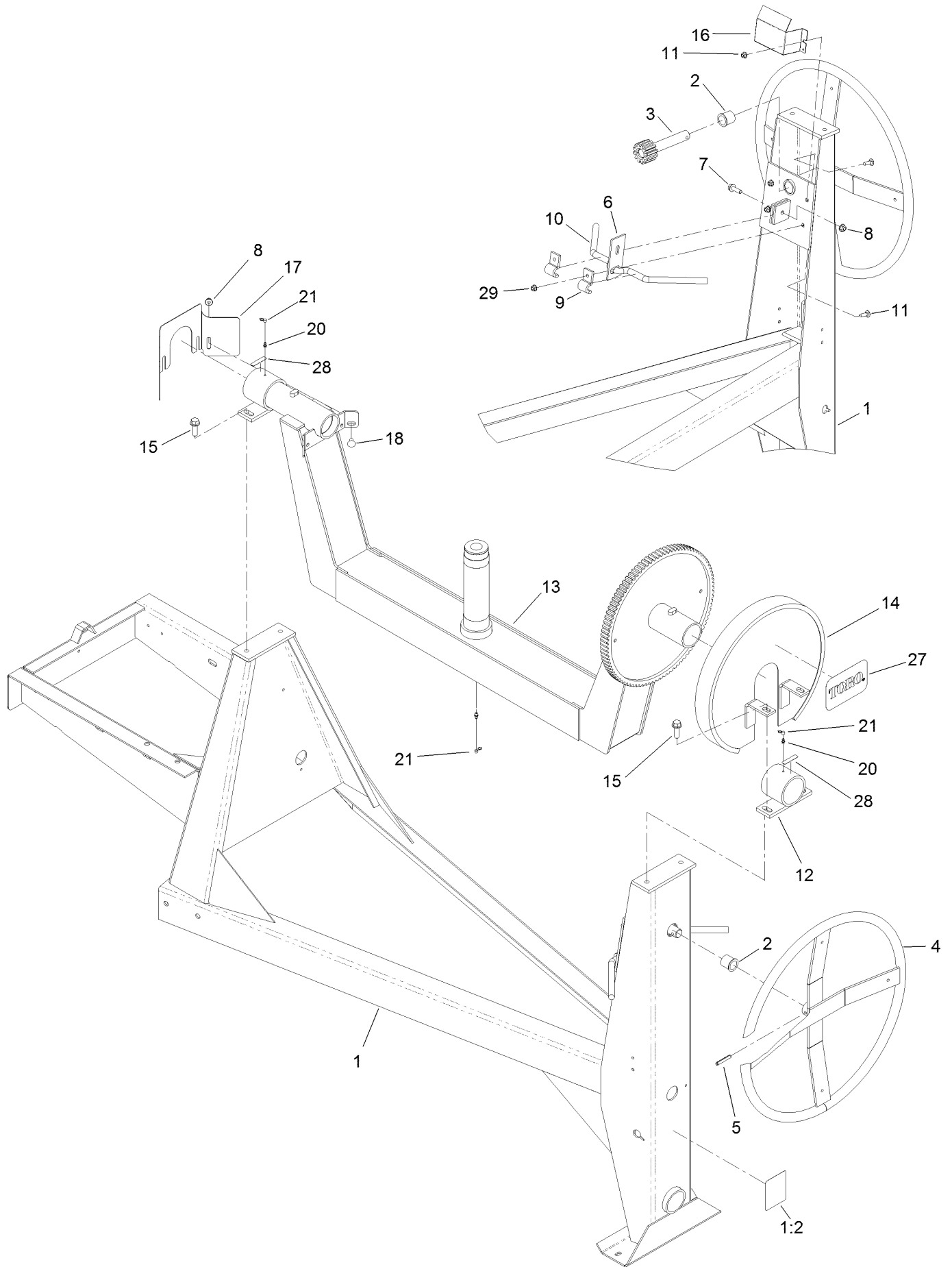

Frame Assembly (continued)

<i>Ref.</i>	<i>Part Number</i>	<i>Qty.</i>	<i>Description</i>	<i>Ref.</i>	<i>Part Number</i>	<i>Qty.</i>	<i>Description</i>
1	127-2815	1	Frame ASM	12	ST24349-03	2	Trunnion
1:2	125-8216	1	Decal-Safety Chain, Towing	13	125-8693	1	Yoke ASM
2	ST32032	2	Bushing-Nylon	14	ST27617-03	1	Guard-Brake, Upper
3	ST22029	1	Shaft-Tilt	15	ST80031	4	Screw-HWH
4	ST22096-03	1	Handwheel	16	ST27618-03	1	Guard-Brake, Lower
5	32121-27	1	Pin-Roll	17	130-2208-03	1	Guard-Pinion
6	ST27619-03	1	Dog-Brake	18	3231-21	2	Screw-CARR
7	3234-24	1	Screw-HHF	20	ST46042	2	Fitting-Grease
8	104-8301	3	Nut-Flange, NI	21	ST47001	3	Cap-Plug
9	ST27559-03	2	Bracket-Handle	27	99-4693	1	Decal
10	ST27621	1	Handle-Brake	28	125-8175	2	Decal-Grease
11	3230-2	4	Bolt-CARR	29	104-8300	4	Nut-Flange, NI

Axle Assembly

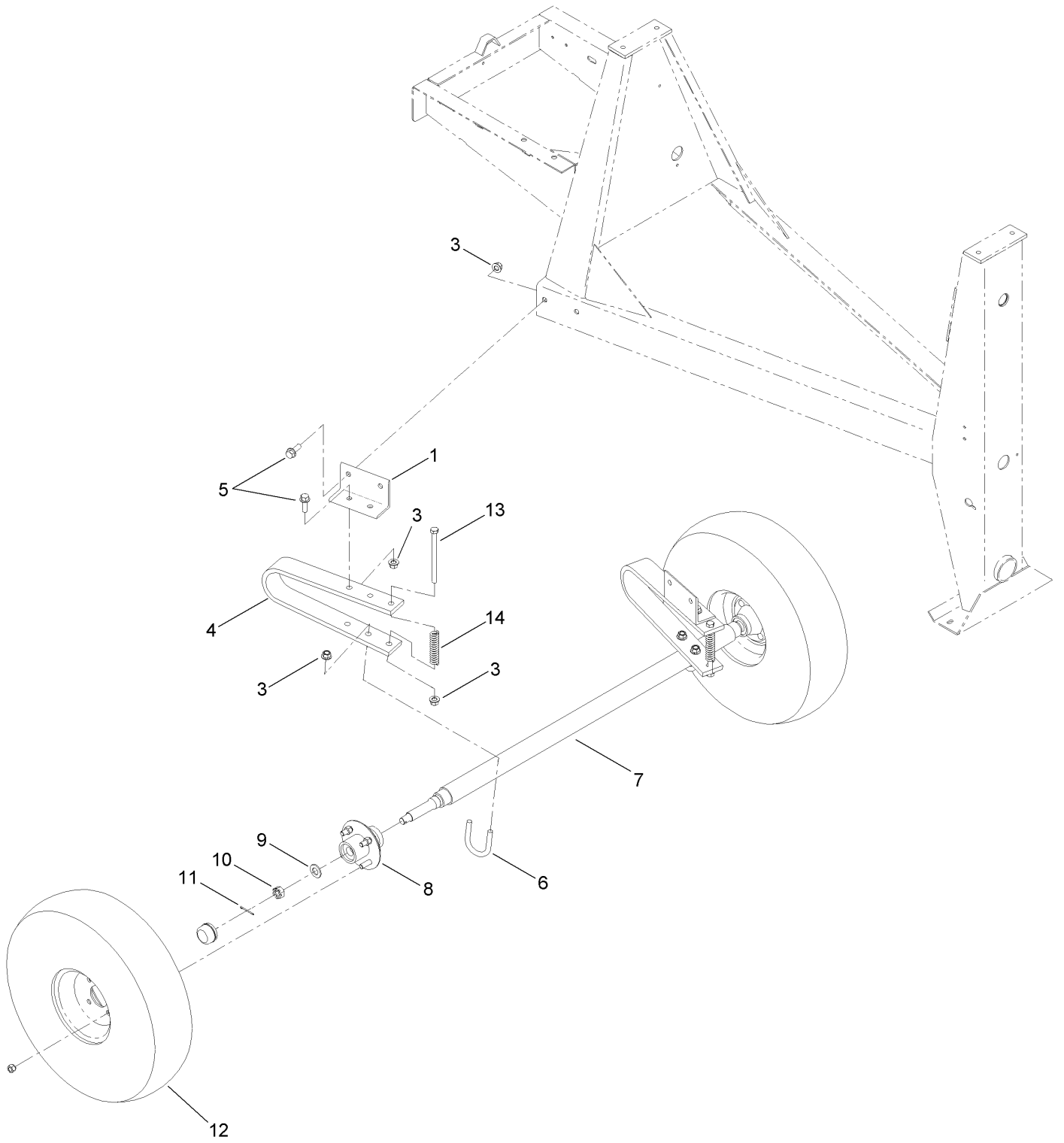

Axle Assembly (continued)

<i>Ref.</i>	<i>Part Number</i>	<i>Qty.</i>	<i>Description</i>	<i>Ref.</i>	<i>Part Number</i>	<i>Qty.</i>	<i>Description</i>
1	ST26949-03	2	Bracket-Axle, Spring	9	3256-28	2	Washer-Flat
3	99-5107	14	Nut-Lock	10	ST80054	2	Nut
4	ST26971	2	Spring-Leaf	11	3272-13	2	Pin-Cotter
5	100-6116	8	Screw-HHF	12	ST32307	2	Tire And Rim ASM
6	ST26195	2	Bolt-U	13	325-33	2	Screw-HH
7	ST21460-03	1	Axle-Spring	14	ST34972	2	Spring-Coil
8	125-8171	2	Hub ASM				

Hub Assembly No. 125-8171

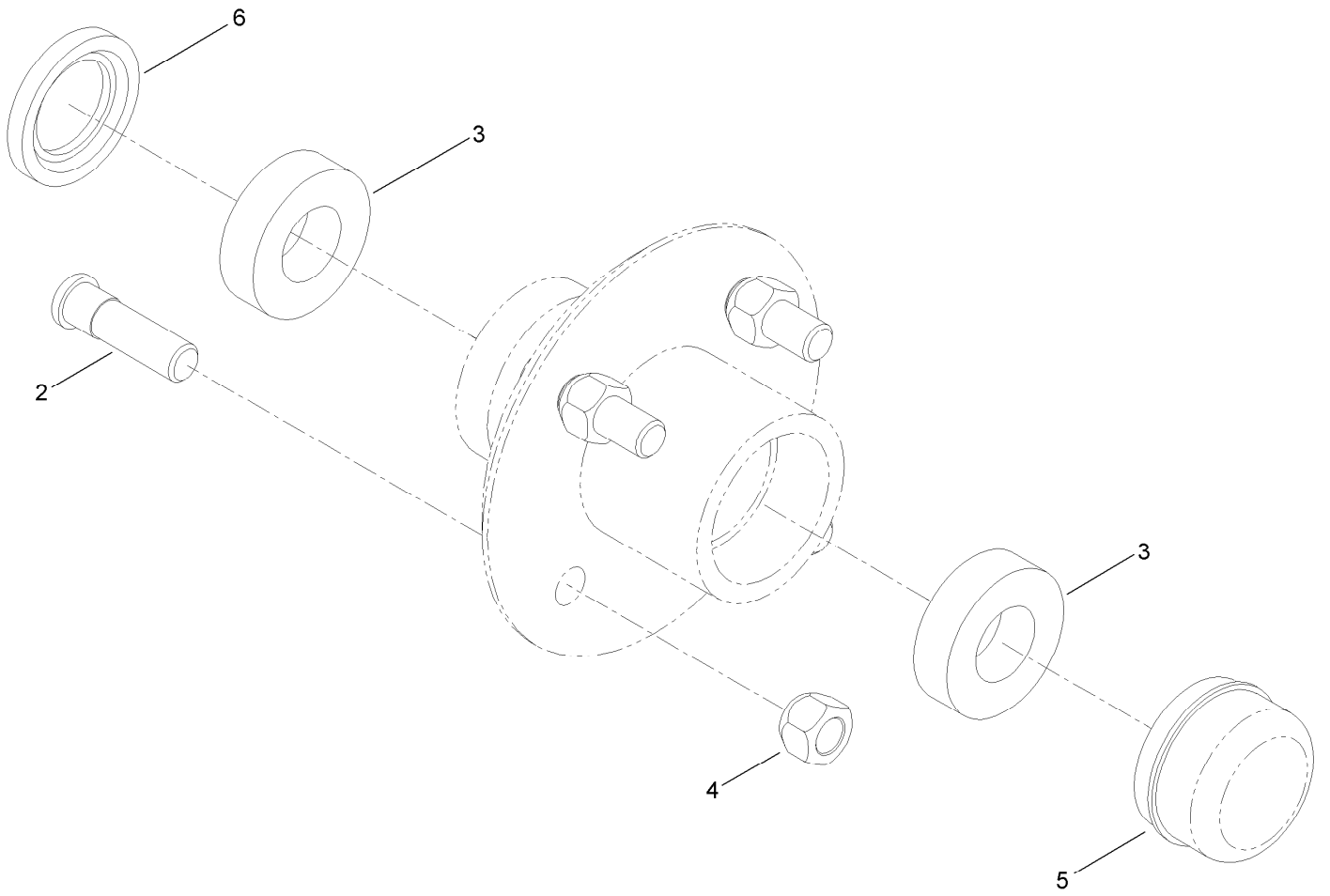

Hub Assembly No. 125-8171 (continued)

<i>Ref.</i>	<i>Part Number</i>	<i>Qty.</i>	<i>Description</i>
2	ST39190	4	Stud-Wheel
3	ST32233	2	Bearing-Roller
4	ST80045	4	Nut-Lug

<i>Ref.</i>	<i>Part Number</i>	<i>Qty.</i>	<i>Description</i>
5	ST34573	1	Cap-Dust
6	ST32052	1	Seal-Hub, Wheel

Engine and Drive Assembly

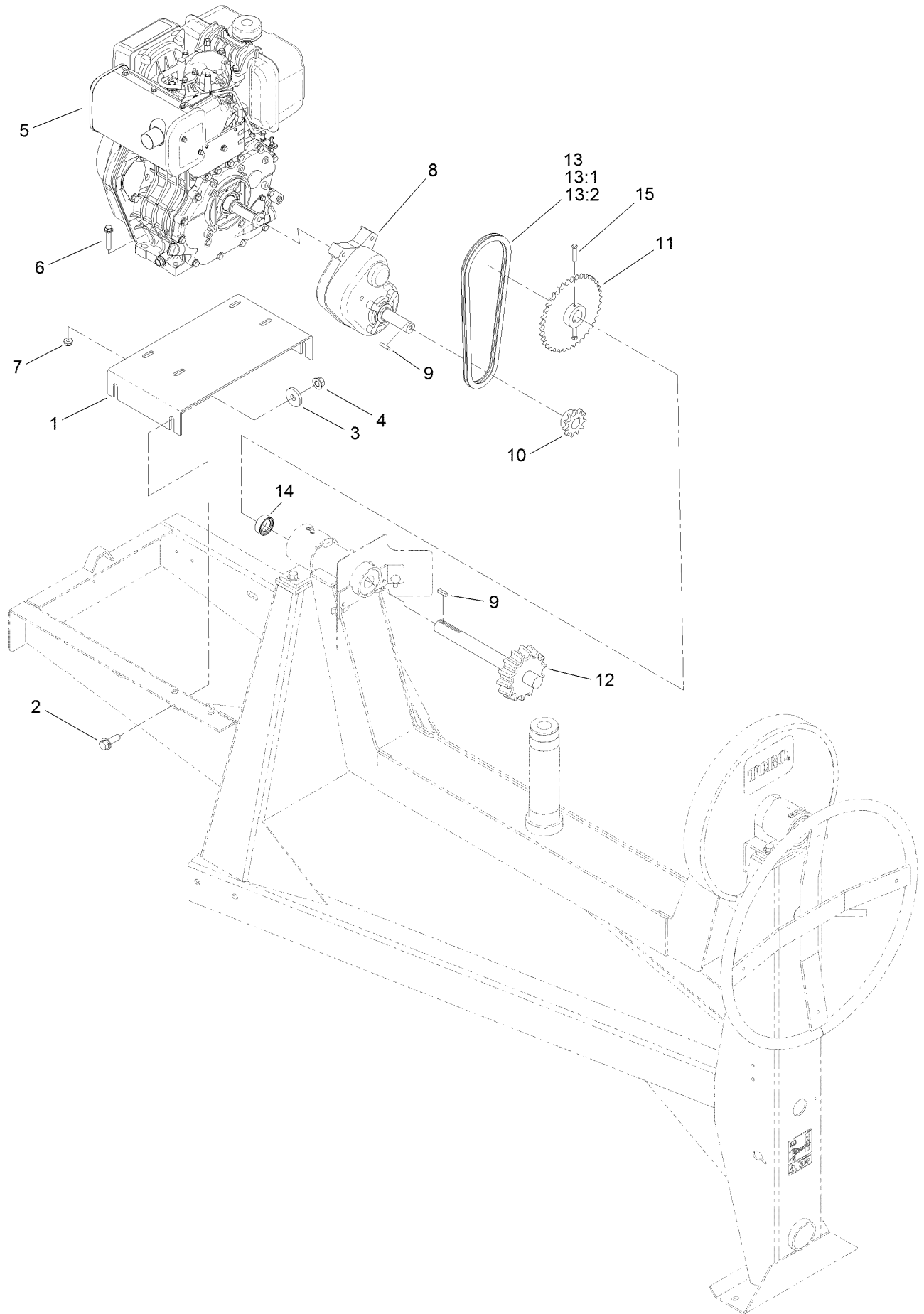

Engine and Drive Assembly (continued)

<i>Ref.</i>	<i>Part Number</i>	<i>Qty.</i>	<i>Description</i>	<i>Ref.</i>	<i>Part Number</i>	<i>Qty.</i>	<i>Description</i>
1	ST39665-03	1	Base-Motor	9	5-7280	2	Key
2	100-6116	4	Screw-HHF	10	ST35284	1	Sprocket
3	ST26326	4	Washer-Flat	11	ST34099	1	Sprocket
4	99-5107	4	Nut-Lock	12	ST21487	1	Shaft-Drive
5	131-2936	1	Engine-Diesel (Yanmar L100W)	13	ST22040	1	Chain Set
6	108-3742	4	Screw-HHF	13:1	ST34102	3	Chain
7	104-8301	4	Nut-Flange, NI	13:2	ST34104	1	Link-Connecting, No. 50
8	ST39667	1	Reducer-Gear	14	ST32176	1	Collar-Locking
				15	909546	2	Screw-Set

Drum Assembly

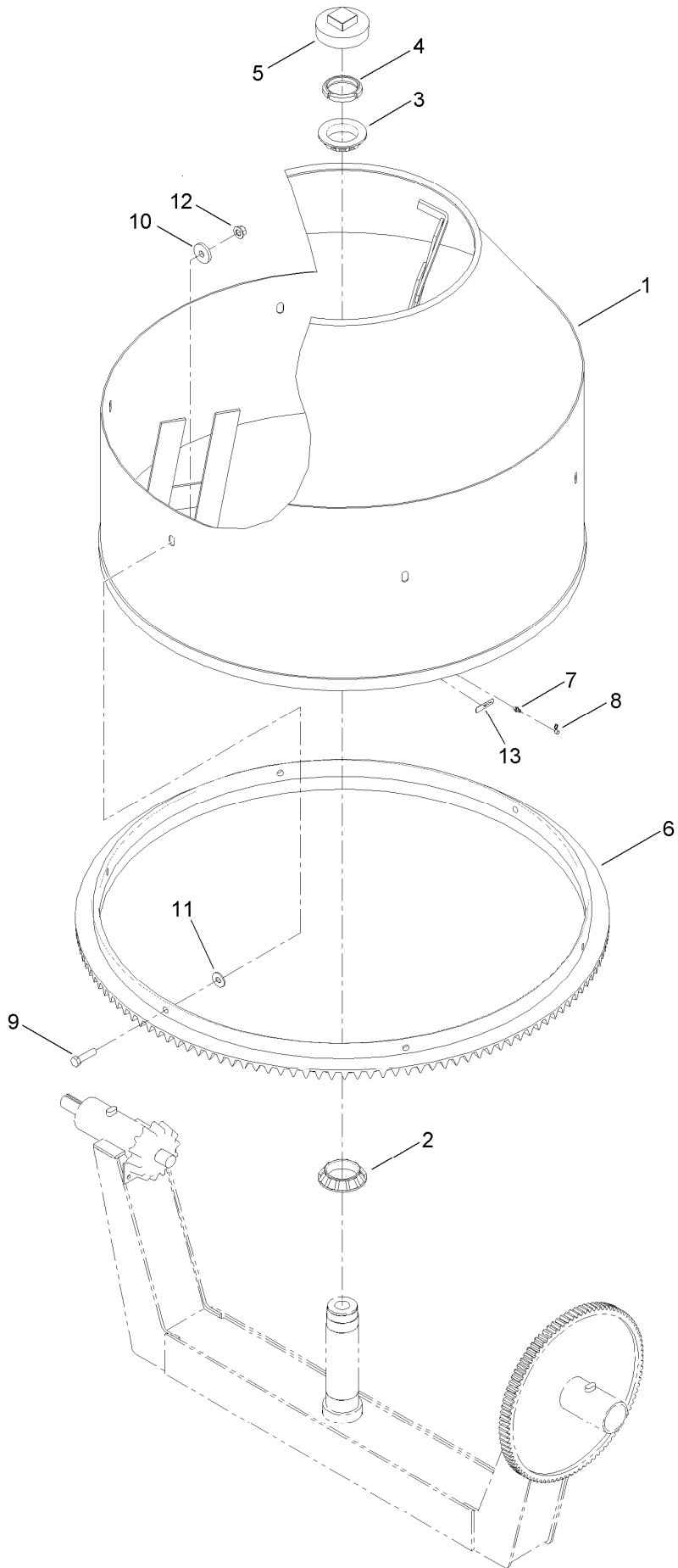

Drum Assembly (continued)

<i>Ref.</i>	<i>Part Number</i>	<i>Qty.</i>	<i>Description</i>	<i>Ref.</i>	<i>Part Number</i>	<i>Qty.</i>	<i>Description</i>
1	125-8687-01	1	Drum	8	ST47001	1	Cap-Plug
2	ST32283	1	Bearing	9	325-8	6	Screw-HH
3	ST32282	1	Bearing	10	ST26326	6	Washer-Flat
4	ST32285	1	Nut-Lock	11	3256-6	6	Washer-Flat
5	ST32287	1	Plug-Pipe	12	99-5107	6	Nut-Lock
6	ST39078-01	1	Gear-Ring	13	125-8175	1	Decal-Grease
7	ST46057	1	Fitting				

Cowl Assembly

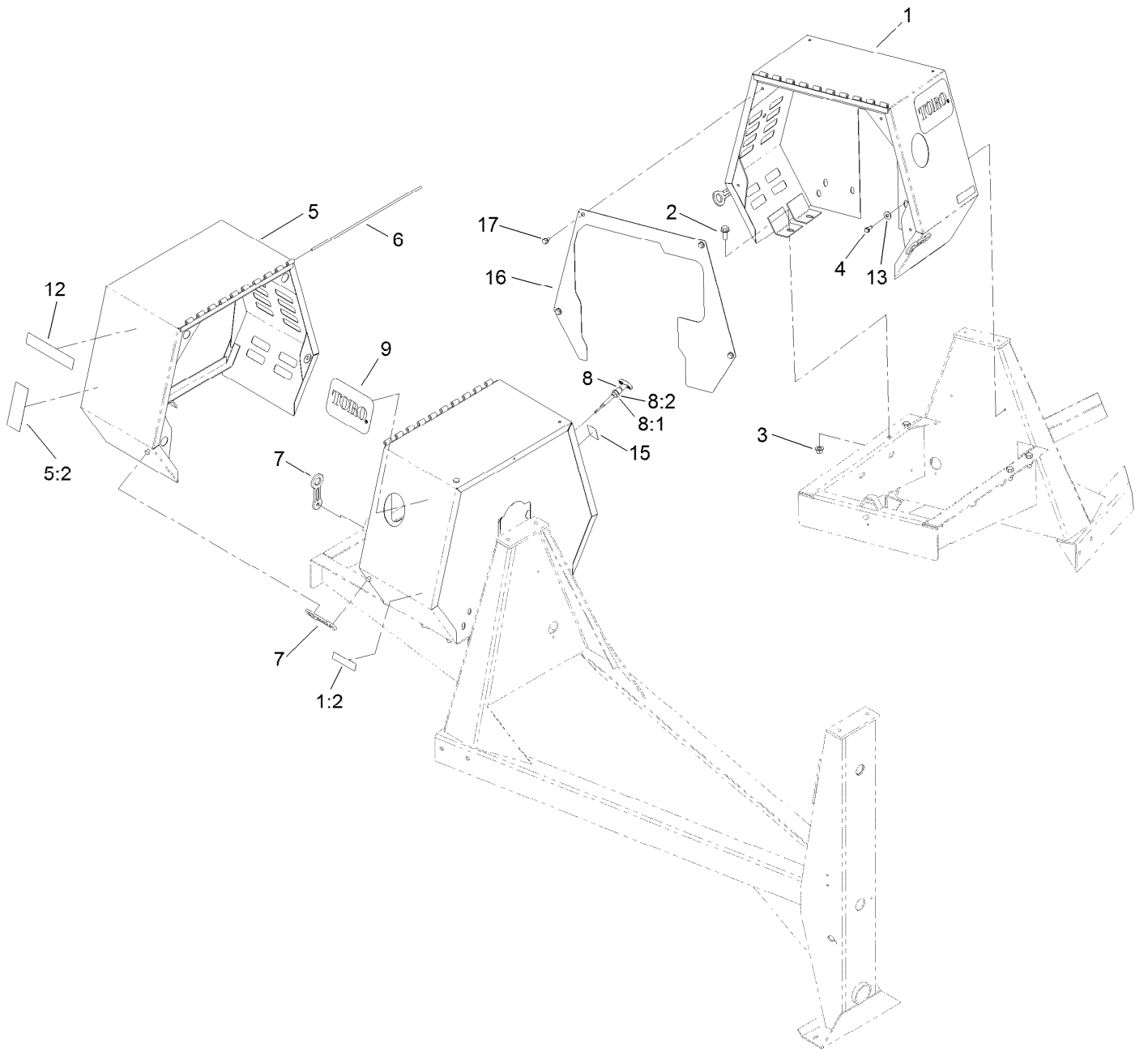

Cowl Assembly (continued)

<i>Ref.</i>	<i>Part Number</i>	<i>Qty.</i>	<i>Description</i>	<i>Ref.</i>	<i>Part Number</i>	<i>Qty.</i>	<i>Description</i>
1	132-7177	1	Cowl ASM	8	132-7173	1	Cable-Throttle, 125Cm
1:2	117-2718	1	Decal-Arrester, Spark	8:1	3220-11	1	Nut-Jam
2	3234-38	4	Screw-HHF	8:2	218-447	1	Washer-Lock
3	99-5107	4	Nut-Lock	9	67-7320	2	Decal
4	701243	2	Screw-HWHTF	12	125-4938	2	Decal
5	127-1685	1	Movable Cowl ASM	13	3256-4	2	Washer-Flat
5:2	125-4939	1	Decal-Warning	15	132-7176	1	Decal-Throttle, Diesel
6	ST44368	1	Pin	16	132-7179-03	1	Plate-Drive, Guard
7	ST47182	3	Latch-Rubber	17	110-9380	4	Screw-HWH

Attachments and Accessories

For 68011 CM-1258Y-SD Concrete Mixer

Product Name	Model/Part
50in Forged Tow Pole Hitch	68057
50in Pintel Tow Pole Hitch	68059
50in Stamped Tow Pole Hitch	68061
Trailer Light Kit.....	68062

Notes:

Notes:

Notes:



Count on it.