



Wheel Horse®
523Dxi Tractor

Model No. 73550 – 8900001 & Up

Operator's Manual

IMPORTANT: Read this manual carefully. It contains information about your safety and the safety of others. Also become familiar with the controls and their proper use before you operate the product.

Introduction

Thank you for purchasing a Toro product.

All of us at Toro want you to be completely satisfied with your new product, so feel free to contact your local Authorized Service Dealer for help with service, genuine replacement parts, or other information you may require.

Whenever you contact your Authorized Service Dealer or the factory, always know the model and serial numbers of your product. These numbers will help the Service Dealer or Service Representative provide exact information about your specific product. You will find the model and serial number plate located in a unique place on the product as shown below.

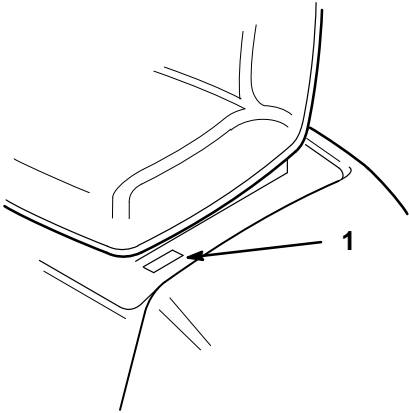

m-2345

1. Model and Serial Number Plate

For your convenience, write the product model and serial numbers in the space below.

Model No. _____
Serial No. _____

Read this manual carefully to learn how to operate and maintain your product correctly. Reading this manual will help you and others avoid personal injury and damage to the product. Although we design, produce and market safe, state-of-the-art products, you are responsible for using the product properly and safely. You are also responsible for training persons, who you allow to use the product, about safe operation.

The warning system in this manual identifies potential hazards and has special safety messages that help you and others avoid personal injury, even death. **DANGER**, **WARNING** and **CAUTION** are signal words used to identify the level of hazard. However, regardless of the hazard, be extremely careful.

DANGER signals an extreme hazard that will cause serious injury or death if the recommended precautions are not followed.

WARNING signals a hazard that may cause serious injury or death if the recommended precautions are not followed.

CAUTION signals a hazard that may cause minor or moderate injury if the recommended precautions are not followed.

Two other words are also used to highlight information. “Important” calls attention to special mechanical information and “Note” emphasizes general information worthy of special attention.

The left and right side of the machine is determined by sitting on the seat in the normal operator’s position.

! WARNING: !
The engine exhaust from this product contains chemicals known to the State of California to cause cancer, birth defects, or other reproductive harm.

Contents

	Page		Page
Safety	2	Re-centering the Steering Wheel	20
Safe Operating Practices	2	Attachment Power Lift	21
Slope Chart	5	Positioning the Seat	22
Safety and Instruction Decals	7	Headlights and Taillights	22
Check Before Operating	8	Positioning the Tilt Steering Wheel	22
Opening the Hood	8	Using the Cruise Control	23
Closing the Hood	9	The Smart Turn™ Steering Feature	24
Removing the Side Panels	9	Pushing the Machine by Hand	24
Adding Fuel	10	Maintenance	25
Draining Water from the Fuel Filter/Water Separator	11	Service Interval Chart	25
Check the Engine Oil Level	11	Engine Oil	27
Check the Cooling System	12	Changing the Engine Coolant	29
Check for Debris	13	Greasing and Lubrication	30
Check the Safety Interlock System	14	Tire Pressure	31
Check the Brake	14	Brake	32
Operation	15	Fuel Tank	33
Think Safety First	15	Fuel Filter	34
Controls	15	Front Wheel Toe-In	34
Parking Brake	15	Transaxle Fluid	35
Starting and Stopping the Engine	16	Fuses	37
Operating the Power Take Off (PTO)	17	Headlights	37
Check the Safety Interlock System	17	Taillights	38
Gauges and Indicator Lights	18	Battery	39
Driving Forward or Backward	19	Wiring Diagram	42
Stopping the Machine	20	Cleaning and Storage	44
		Troubleshooting	45

Safety

This machine meets or exceeds the B71.1–1996 specifications of the American National Standards Institute, in effect at the time of production. However, improper use or maintenance by the operator or owner can result in injury. To reduce the potential for injury, comply with these safety instructions and always pay attention to the safety alert  symbol, which means CAUTION, WARNING, or DANGER—“personal safety instruction.” Failure to comply with the instruction may result in personal injury or death.

Safe Operating Practices

This product is capable of amputating hands and feet and throwing objects. Always follow all safety instructions to avoid serious injury or death.

 WARNING
POTENTIAL HAZARD <ul style="list-style-type: none">• Engine exhaust contains carbon monoxide, which is an odorless, deadly poison.
WHAT CAN HAPPEN <ul style="list-style-type: none">• Carbon monoxide can kill you and is also known to the State of California to cause birth defects.
HOW TO AVOID THE HAZARD <ul style="list-style-type: none">• Do not run engine indoors or in an enclosed area.

General Operation

1. Read, understand, and follow all instructions in the operator’s manual and on the machine before starting.
2. Allow only responsible adults who are familiar with the instructions to operate the machine.
3. Clear the area of objects such as rocks, toys, wire, etc., which could be picked up and thrown by the blade.
4. Be sure the area is clear of other people before mowing. Stop the machine if anyone enters the area.
5. Never carry passengers.
6. Do not mow in reverse unless absolutely necessary. Always look down and behind before and while backing.
7. Be aware of the mower discharge direction and do not point it at anyone. Do not operate the mower without either the entire grass catcher or the guard in place.
8. Slow down before turning. Sharp turns on any terrain may cause loss of control.
9. Never leave a running machine unattended. Always turn off blades, set parking brake, stop engine, and remove key before dismounting.
10. Turn off blades when not mowing.
11. Keep hands, feet, hair and loose clothing away from attachment discharge area, underside of mower and any moving parts while engine is running.
12. Stop the engine before removing the grass catcher or unclogging the chute.

13. Mow only in daylight or good artificial light.
14. Do not operate the machine while under the influence of alcohol or drugs.
15. Watch for traffic when operating near or crossing roadways.
16. Use extra care when loading or unloading the machine onto a trailer or truck.
17. Do not touch equipment or attachment parts which may be hot from operation. Allow to cool before attempting to maintain, adjust or service.

Slope Operation

Slopes are a major factor related to loss-of-control and tip-over accidents, which can result in severe injury or death. All slopes require extra caution. If you cannot back up the slope or if you feel uneasy on it, do not mow it.

DO

- Mow up and down slopes greater than 5°, not across.
- Mow downhill only on slopes above 10°, never mow uphill. If a steep slope must be ascended, back up the hill, and drive forward down the hill, keeping the machine in gear.
- Remove obstacles such as rocks, tree limbs, etc. from the mowing area. Watch for holes, ruts or bumps, as uneven terrain could overturn the machine. Tall grass can hide obstacles.
- Use slow speed. Choose a low gear so that you will not have to stop or shift while on the slope.
- Follow the manufacturer's recommendations for wheel weight or counterweights to improve stability.
- Use extra care with grass catchers or other attachments. These can change the stability of the machine.

- Keep all movement on slopes slow and gradual. Do not make sudden changes in speed or direction.
- Avoid starting or stopping on a slope. If tires lose traction, disengage the blades and proceed slowly straight down the slope.

DO NOT

- Do not operate machine on hillsides or slopes exceeding 15°.
- Avoid turning on slopes. If you must turn, turn slowly and gradually downhill, if possible.
- Do not mow near drop-offs, ditches, or embankments. The machine could suddenly turn over if a wheel goes over the edge of a cliff or ditch, or if an edge caves in.
- Do not mow on wet grass. Reduced traction could cause sliding.
- Do not try to stabilize the machine by putting your foot on the ground.
- Do not use a grass catcher on steep slopes. Heavy grass bags could cause loss of control or overturn the machine.

Children

Tragic accidents can occur if the operator is not alert to the presence of children. Children are often attracted to the machine and the mowing activity. Never assume that children will remain where you last saw them. The following requirements must be followed to prevent injury to children.

1. Keep children out of the mowing area and under the watchful care of another responsible adult.
2. Be alert and turn the machine off if children enter the area.
3. Before and while backing, look behind and down for small children.
4. Never carry children. They may fall off and be seriously injured or interfere with safe machine operation.
5. Never allow children to operate the machine.
6. Use extra care when approaching blind corners, shrubs, trees, the end of a fence or other objects that may obscure vision.

Service

1. Stop the engine, set the parking brake, and remove the key from the ignition switch before performing any service, repairs, maintenance or adjustments.
2. Use extra care when handling gasoline and other fuels. They are flammable and vapors are explosive.
 - A. Use only an approved container.
 - B. Never remove the gas cap or add fuel when the engine is running. Allow the engine to cool before refueling. Do not smoke.
 - C. Never refuel the machine indoors.
 - D. Never store the machine or fuel container inside where there is an open flame, such as near a water heater or furnace.

3. Never run a machine inside a closed area.
4. Keep nuts and bolts tight, especially the blade attachment bolts. Keep equipment in good condition.
5. Never tamper with safety devices. Check safety systems for proper operation before each use.
6. Keep the machine free of grass, leaves, or other debris build-up. Clean up oil or fuel spillage. Allow the machine to cool before storing.
7. Stop and inspect the equipment if you strike an object. Repair, if necessary, before restarting.
8. Grass catcher components are subject to wear, damage and deterioration, which could expose moving parts or allow objects to be thrown. Frequently check components and replace with manufacturer's recommended parts, when necessary.
9. Mower blades are sharp and can cut. Wrap the blade(s) or wear gloves, and use extra caution when servicing them.
10. Use only genuine replacement parts to ensure that original standards are maintained.
11. Check brake operation frequently. Adjust and service as required.
12. Battery acid is poisonous and can cause burns. Avoid contact with skin, eyes and clothing. Protect your face, eyes and clothing when working with a battery.
13. Battery gases can explode. Keep cigarettes, sparks and flames away from battery.

Slope Chart

Read all safety instructions on pages 2-4.

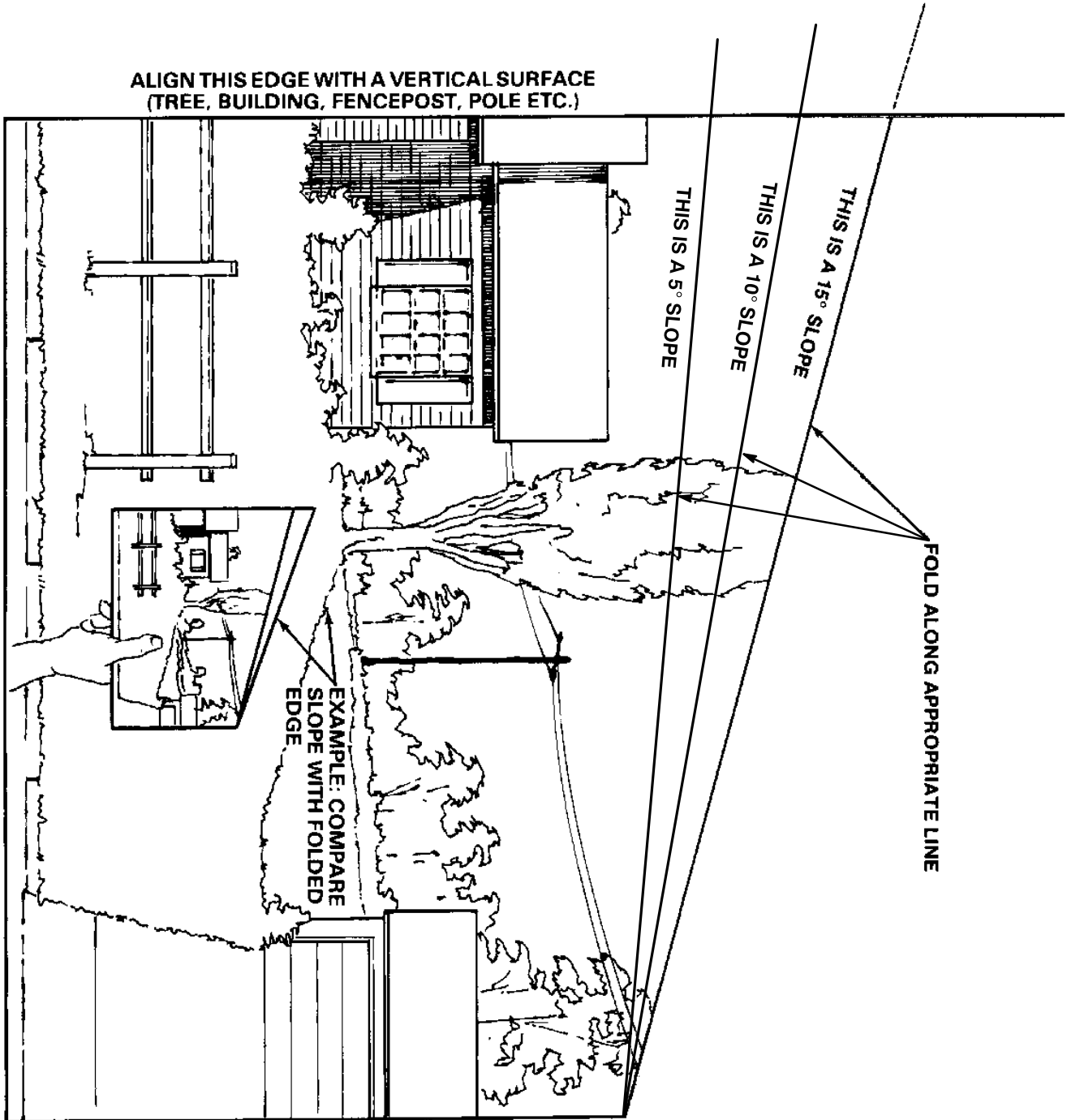

Safety and Instruction Decals



Safety decals and instructions are easily visible to the operator and are located near any area of potential danger. Replace any decal that is damaged or lost.

ON DRIVE SHAFT COVER
(Part No. 95-4263)

<p>TRACTION CONTROL PEDAL</p>		<p>BRAKE PEDAL</p>
<p>⚠ DANGER</p> <p>TO AVOID SERIOUS INJURY OR DEATH,</p> <ul style="list-style-type: none"> • READ AND UNDERSTAND THE OPERATOR'S MANUAL. • KNOW LOCATION AND FUNCTION OF CONTROLS. • NEVER USE WHEN UNDER THE INFLUENCE OF ALCOHOL OR DRUGS. • USE SAFELY; MACHINE IS NOT A TOY; NEVER LET CHILDREN OPERATE. • KEEP SAFETY DEVICES IN PLACE & WORKING; CHECK BEFORE EACH USE. • SAFETY INTERLOCKS CAN FAIL; NEVER ASSUME BLADE IS STOPPED. • STOP ENGINE, SET PARKING BRAKE & REMOVE KEY IF LEAVING MACHINE. • REMOVE OBJECTS THAT COULD BE THROWN BY THE BLADE. • GO UP AND DOWN SLOPES, NOT ACROSS. • AVOID SHARP OR SUDDEN TURNS AND SLIPPERY OR STEEP AREAS. • IF MACHINE STOPS GOING UPHILL, STOP BLADE & BACK SLOWLY DOWN. 		
<ul style="list-style-type: none"> • ROTATING BLADES CAN CUT OFF ARMS AND LEGS. • NEVER MOW WHEN CHILDREN OR OTHERS ARE NEAR. • NEVER CARRY CHILDREN OR OTHER PASSENGERS; THEY FALL OFF. • LOOK DOWN AND BEHIND BEFORE AND WHILE BACKING UP. <p>REPLACEMENT MANUAL AVAILABLE BY SENDING COMPLETE MODEL NUMBER TO: THE TORO CO., 8111 LYNDALE AVE. S., BLOOMINGTON, MN 55420-1196 U.S.A. 99-4263</p>		

ON REAR FENDER
(Part No. 98-3088)



ON RADIATOR FAN SHROUD
(Part No. 95-4143)



ON DRIVE SHAFT TUNNEL
(Part No. 80-8760)

<p>⚠ DANGER</p>
<p>DO NOT OPERATE THIS UNIT. 80-8760 DRIVE SHAFT GUARD IS NOT IN PLACE.</p>

(2) UNDER SIDE SHIELD
(Part No. 98-5014)

<p>⚠ WARNING</p>	98-5014
<p>DO NOT OPERATE THIS UNIT UNLESS HOOD SIDE PANELS ARE IN PLACE.</p>	

(2) INSIDE FRONT GRILL
(Part No. 93-8069)

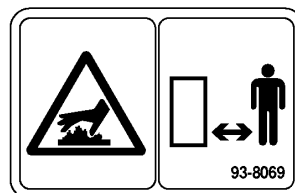

Check Before Operating

Each time before operating your tractor, check the following:

- Fuel level
- Water drained from the fuel filter
- Engine oil level
- Cooling system fluid level and radiator screen
- Debris on the (3) air intake screens
- Debris in the engine area
- Debris on the rear transaxle cover
- The safety interlock system
- The brake

Some of these steps will require that you open the hood or remove the side panels on the tractor.

Opening the Hood

To open the hood:

1. Park the machine on a level surface, disengage the power take off (PTO), set the parking brake, lower the attachment lift, and turn the ignition key to “STOP” to stop the engine. Remove the key.
2. Push the hood latch (Fig. 1), located just above the indicator light panel, to the left.
3. Raise the hood to full height.

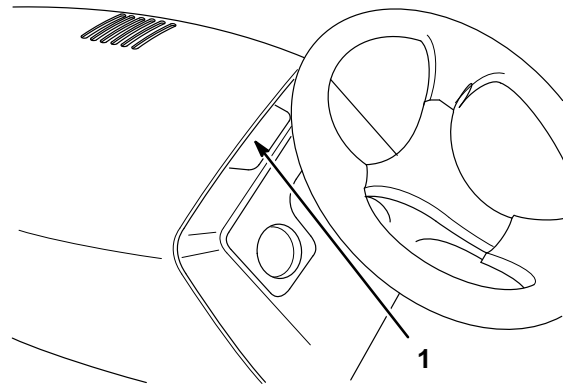

m-3314

Figure 1

1. Hood latch

CAUTION

POTENTIAL HAZARD

- **Components under the hood will be hot if the tractor has been running.**

WHAT CAN HAPPEN

- **Touching hot components can cause burns.**

HOW TO AVOID THE HAZARD

- **Allow the tractor to cool before performing maintenance or touching components under the hood.**

Closing the Hood

1. Lift up on the prop rod as you begin to lower the hood.
2. Push the hood down until the latch closes.

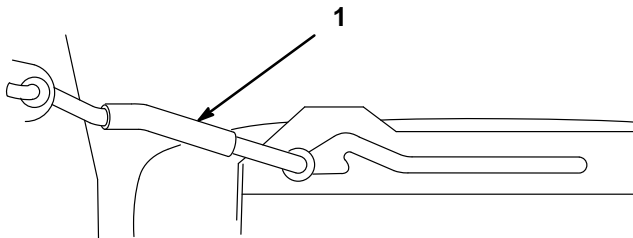

m-3438

Figure 2

1. Prop rod

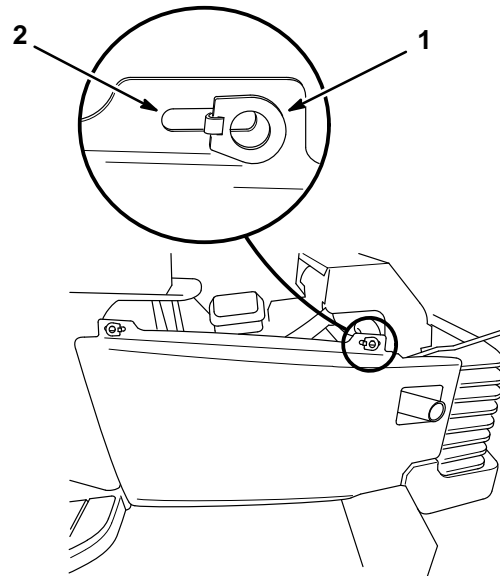

m-3318

Figure 3

1. Side panel latch
2. Open slot

Removing the Side Panels

1. Park the machine on a level surface, disengage the power take off (PTO), set the parking brake, lower the attachment lift, and turn the ignition key to "STOP" to stop the engine. Remove the key.
2. Raise the hood.
3. To remove a side panel:
 - A. Lift up and twist each of the two side panel latches 90°, or until they line up with the open slot (Fig. 3).
 - B. Pull the top of the side panel toward you until the side panel latches pass through the open slot.
 - C. Lift the side panel from the tractor.

DANGER

POTENTIAL HAZARD

- Rotating fan and drive shaft can cause injury.

WHAT CAN HAPPEN

- Fingers, hands or loose clothing can get caught by rotating fan and drive shaft.

HOW TO AVOID THE HAZARD

- Do not operate the tractor without the side panels and hood in place.
- Keep fingers, hands and clothing clear of rotating fan and drive shaft.
- Shut off the engine and remove the key before performing maintenance.

Adding Fuel

The engine runs on clean, fresh diesel fuel with a minimum cetane rating of 40. Purchase fuel in quantities that can be used within 30 days to assure fuel freshness.

Use summer grade diesel fuel (No. 2-D) at temperatures above 20° F (-7° C) and winter grade diesel fuel (No. 1-D or No. 1-D/2-D blend) below 20° F (-7° C). Use of winter grade diesel fuel at lower temperatures provides lower flash point and pour point characteristics, therefore easing startability and lessening chances of chemical separation of the fuel due to lower temperatures (wax appearance, which may plug filters).

Use of summer grade diesel fuel above 20° F (-7° C) will contribute toward longer life of the pump components.

IMPORTANT: Do not use kerosene or gasoline instead of diesel fuel. Failure to observe this caution will damage the engine.

DANGER

POTENTIAL HAZARD

- Under certain conditions, fuel is extremely flammable and highly explosive.

WHAT CAN HAPPEN

- A fire or explosion from fuel can burn you, others, and cause property damage.

HOW TO AVOID THE HAZARD

- Use a funnel and fill the fuel tank outdoors, in an open area, when the engine is cold. Wipe up any fuel that spills.
- Do not fill the fuel tank completely full. Add fuel to the fuel tank until the level is 1/4" to 1/2" (6 mm to 13 mm) below the bottom of the filler neck. This empty space in the tank allows fuel to expand.
- Never smoke when handling fuel, and stay away from an open flame or where fuel fumes may be ignited by a spark.
- Store fuel in an approved container and keep it out of the reach of children. Never buy more than a 30-day supply.

1. Park the machine on a level surface, disengage the power take off (PTO), set the parking brake, lower the attachment lift, and turn the ignition key to "STOP" to stop the engine. Remove the key.
2. Clean around the fuel tank cap and remove the cap. Use a funnel and add fuel until the fuel level is 1/4 to 1/2 inch (6 mm to 13 mm) below the bottom of the filler neck. This space in the tank allows fuel to expand. Do not fill the fuel tank completely.
3. Install the fuel cap securely. Wipe up any fuel that may have spilled.
4. If possible, fill the fuel tank after each use. This will minimize possible buildup of condensation inside the fuel tank.

Draining Water from the Fuel Filter/Water Separator

Any water accumulation should be drained from the fuel filter/water separator before each use.

1. Park the machine on a level surface, disengage the power take off (PTO), set the parking brake, lower the attachment lift, and turn the ignition key to “STOP” to stop the engine. Remove the key.
2. Open the hood.
3. Remove the left-hand side panel.
4. Open the drain valve on the fuel filter/water separator and drain any accumulated water (Fig. 4).

Note: Because the accumulated water will be mixed with diesel fuel, drain the fuel filter into a suitable container and dispose of properly.

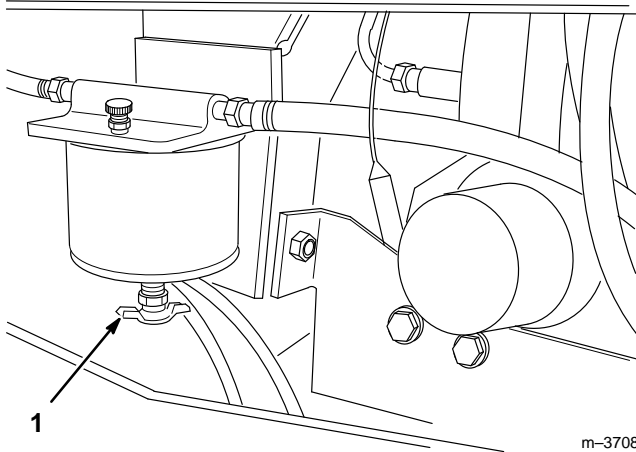

Figure 4

1. Fuel filter drain valve

Check the Engine Oil Level

1. Park the machine on a level surface, disengage the power take off (PTO), set the parking brake, lower the attachment lift, and turn the ignition key to “STOP” to stop the engine. Remove the key.
2. Open the hood.
3. Clean around the oil dipstick (Fig. 5) so dirt cannot fall into the dipstick hole and damage the engine.
4. Pull out the oil dipstick and wipe the metal end clean (Fig. 6).
5. Slide the oil dipstick fully into the tube. Pull the dipstick out and look at the metal end. If the oil level is near or below the lower hole on the dipstick, remove the filler cap and add oil only to the upper hole on the dipstick. (Refer to Engine Oil, page 27, for the correct oil type and viscosity to use in different temperature conditions).
6. After filling with or changing the oil, close the hood, start the engine, and run it at idle for 30 seconds. Shut off the engine. Wait 30 seconds and check the oil level. Add oil, if required, to bring the level to the upper hole on the dipstick.

IMPORTANT: Do not overfill the crankcase with oil because this may result in engine damage.

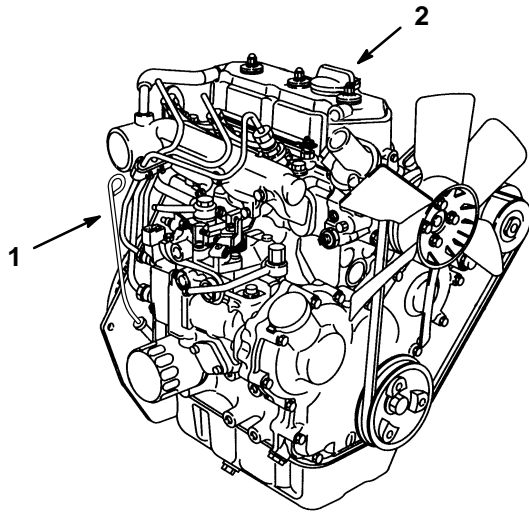

m-3741

Figure 5

1. Dipstick 2. Filler Cap

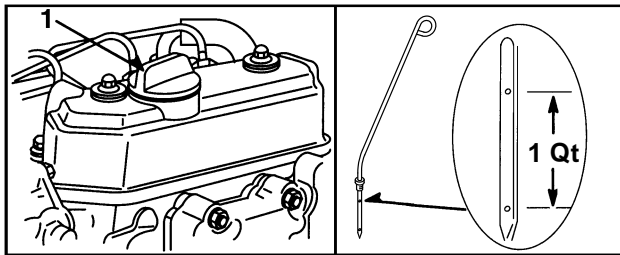

m-3742

Figure 6

1. Filler Cap

Check the Cooling System

Check Radiator Coolant

The cooling system is filled with a 50/50 solution of water and permanent ethylene glycol anti-freeze. Check the level of coolant at the beginning of each day before starting the engine.

! DANGER

POTENTIAL HAZARD

- Coolant is hot and pressurized.

WHAT CAN HAPPEN

- Discharge of hot pressurized coolant can cause severe burns.

HOW TO AVOID THE HAZARD

- Do not remove the radiator cap to check coolant. Follow the directions below for checking coolant.
- Do not remove the radiator cap when the engine is hot. Always allow the engine to cool at least 15 minutes or until the radiator cap is cool enough to touch without burning your hand before removing the radiator cap.

1. Park the machine on a level surface, disengage the power take off (PTO), set the parking brake, lower the attachment lift, and turn the ignition key to "STOP" to stop the engine. Remove the key.
2. Open the hood.
3. Check coolant level. Coolant should be between the two lines on the reserve tank when the engine is cold (Fig. 7).

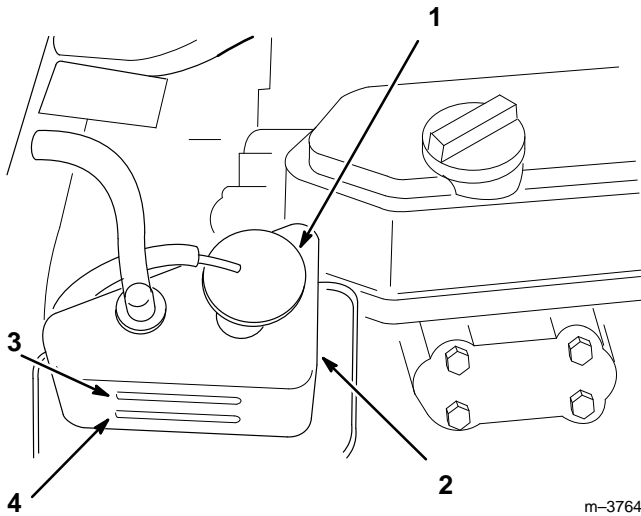

Figure 7

- | | |
|---------------------|------------------------------|
| 1. Reserve tank cap | 3. Maximum level line (cold) |
| 2. Reserve tank | 4. Minimum level line (cold) |

- If coolant is low, remove the reserve tank cap and add a 50/50 mixture of water and permanent ethylene glycol anti-freeze. **DO NOT OVERFILL.**
- Install the reserve tank cap.

Check for Debris

IMPORTANT: Operating the engine with a blocked grass screen and/or cooling shrouds removed, will result in engine damage from overheating.

- Park the machine on a level surface, disengage the power take off (PTO), set the parking brake, lower the attachment lift, and turn the ignition key to “STOP” to stop the engine. Remove the key.
- Check for debris on the (3) air intake screens (Fig. 8). Wipe away debris before each use and/or during use, if required.

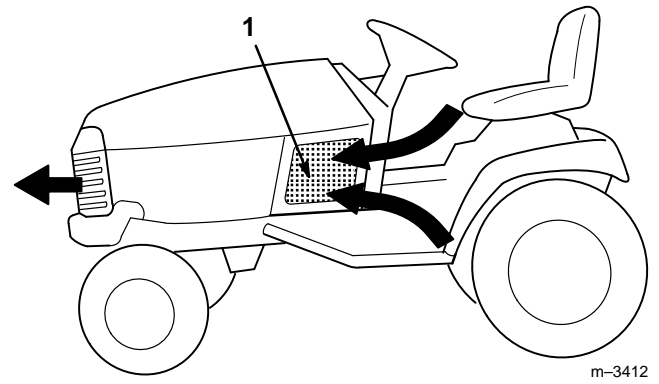

Figure 8

Arrows show air intake and exhaust path

- Air intake screens (1 of 3 shown)

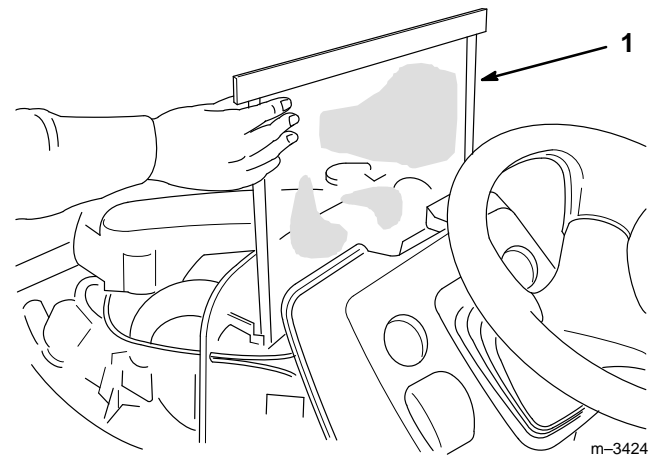

Figure 9

- Radiator screen

- The radiator screen (Fig. 9) is located between the radiator and the dash in the tractor. To remove it, pull it up from its retention slot. Wipe or wash off all accumulated debris from the screen, then reinstall it.
- Debris can build up in the engine area. Clean any debris build-up with a brush or blower before each use.

IMPORTANT: It is preferable to blow dirt out (Fig. 10), rather than washing it out. If water is used, keep it away from electrical items.

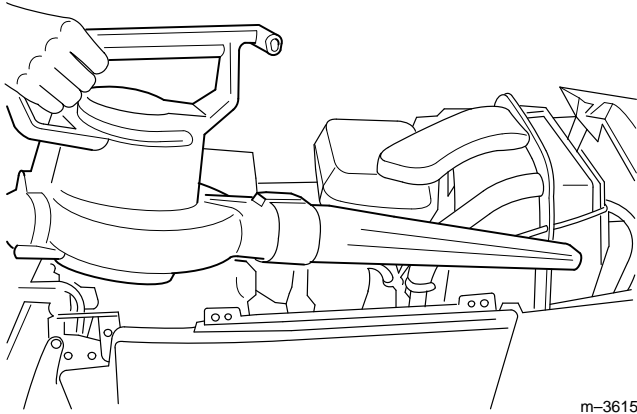

Figure 10

IMPORTANT: DO NOT HIGH-PRESSURE WASH. High-pressure washing can damage the electrical system or deplete grease.

5. The rear transaxle cover is an air intake area for cooling the transaxle. Clean debris from the rear transaxle cover before operating the tractor (Fig. 11).

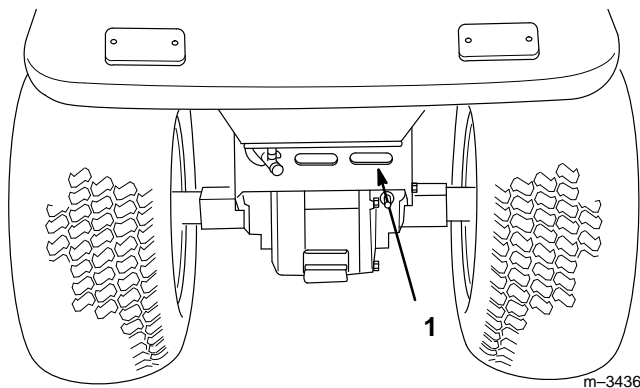

Figure 11

1. Rear transaxle cover

Check the Safety Interlock System

Always check the interlock system before operating the tractor. Instructions for checking the interlock system are found in the Operation section, page 15.

Check the Brake

Refer to Checking and Adjusting the Brake, page 32.

Operation

Think Safety First

Please carefully read all the safety instructions on pages 2–7. Knowing this information could help you, your family, pets or bystanders avoid injury.

Controls

Become familiar with all the controls (Fig. 12) before you start the engine and operate the machine.

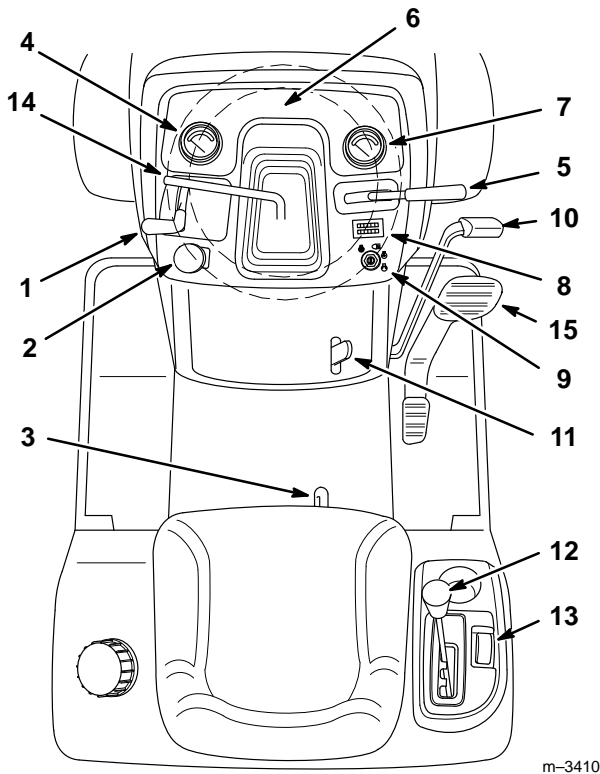

Figure 12

m-3410

- | | |
|-------------------------------------|-------------------------------|
| 1. Throttle | 8. Hour meter |
| 2. PTO switch | 9. Ignition switch |
| 3. Seat adjustment lever | 10. Brake pedal |
| 4. Engine coolant temperature gauge | 11. Parking brake lever |
| 5. Attachment lift lever | 12. High-Low range lever |
| 6. Indicator lights | 13. Cruise control switch |
| 7. Fuel gauge | 14. Steering wheel tilt lever |
| | 15. Traction control pedal |

Parking Brake

Always set the parking brake when you stop the machine or leave it unattended.

Setting the Parking Brake

1. Push the brake pedal (Fig. 12) down and hold it in the depressed position.
2. Lift the parking brake lever (Fig. 12) up and gradually take your foot off the brake pedal. The brake pedal should stay in the depressed (locked) position.

Releasing the Parking Brake

1. Push down on the brake pedal (Fig. 12). The parking brake lever should release.
2. Release the brake pedal.

Starting and Stopping the Engine

Starting in Normal Weather

1. Sit down on the seat.

2. Depress the brake pedal.

Note: The engine will not start unless you fully depress the brake pedal.

3. Push the PTO (power take off) switch to OFF (Fig. 13).

4. Move the throttle lever to SLOW (Fig. 13).

5. Turn the ignition key clockwise to the RUN position (Fig. 14). The glow plug indicator light will come on.

6. After the glow plug indicator light goes out, turn the key to the START position. When the engine starts, release the key.

IMPORTANT: Use starting cycles of no more than 30 seconds per minute to avoid overheating the starter motor.

7. If the engine does not start immediately, move the throttle control to FAST and turn the key to the START position.

Note: Additional starting cycles may be required when starting the engine for the first time after the fuel system has been completely without fuel.

8. Move the throttle to the SLOW position (if in FAST) and let the engine warm up a few minutes before applying load.

Starting in Cold Weather (Below 20°F or -7°C)

Note: Use the correct engine oil for the starting temperature; refer to Engine Oil, page 27.

1. Start the engine with the throttle in the FAST position.

Note: Do not use fuel left over from summer. Use only fresh winter grade diesel fuel.

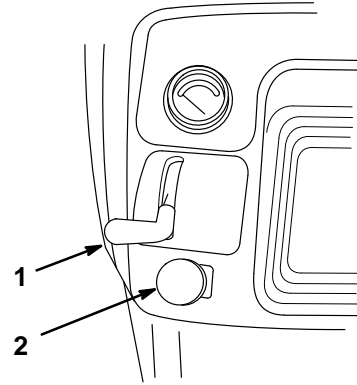

m-3411

Figure 13

1. Throttle

2. PTO switch

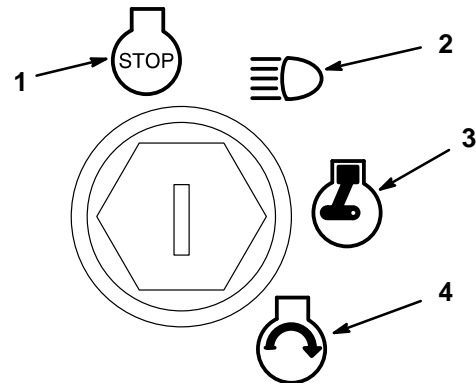

m-3312

Figure 14

1. Stop

2. Run with lights

3. Run (and glow plug)

4. Start

Stopping

1. Move the throttle lever to SLOW (Fig. 13).

2. Allow the engine to run for a short time to cool down.

3. Turn the ignition key to STOP (Fig. 14).

4. Always remove the key from the starter switch when equipment is not in use or unattended.

Operating the Power Take Off (PTO)

The power take-off (PTO) switch engages and disengages power to the electric clutch.

If the ignition key is in the RUN or LIGHTS position and the power take off (PTO) is engaged, the PTO indicator light will be on. When this light is on, it is a reminder: the implement is being powered and the starter will not crank while the PTO is engaged. Always turn off the PTO before getting off the seat.

Engaging the Power Take Off (PTO)

1. Depress the brake pedal to stop the machine.
2. Move the throttle lever to FAST.

IMPORTANT: For best performance, always use full throttle when the power take off (PTO) switch is ON.

3. Pull the power take off (PTO) switch to ON (Fig. 15).

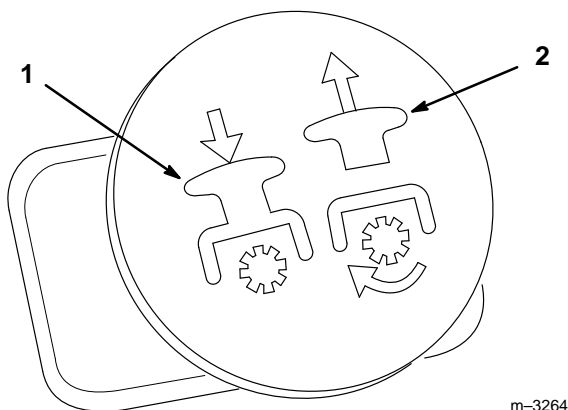

Figure 15

1. Push (off-disengaged)
2. Pull (on-engaged)

Disengaging the Power Take Off (PTO)

1. Push the power take off (PTO) switch to OFF.

Check the Safety Interlock System

Understanding the Safety Interlock System

The safety interlock system is designed to prevent the engine from starting unless:

- You are sitting on the seat
- The brake pedal is depressed
- The power take off (PTO) is OFF

The safety interlock system will stop the engine if you rise from the seat when the brake pedal is released or the power take off (PTO) is ON.

Testing the Safety Interlock System

Test the safety interlock system each time before you use the machine. Do not operate the machine if the safety system is not functioning properly. If the safety system does not operate as described below, have an Authorized Service Dealer repair the safety system immediately.

1. Fully depress the brake pedal. Pull the power take-off (PTO) switch to ON. Now turn the ignition key to START. The starter should not crank.
2. Push the power take-off (PTO) switch to OFF and release the brake pedal. Now turn the ignition key to START; the starter should not crank.
3. Fully depress the brake pedal and set the parking brake. Push the PTO switch to OFF and rise from the seat. Now turn the key to START. The starter should not crank.
4. Fully depress the brake pedal and set the parking brake. Push the power take-off (PTO) switch to OFF. Now start the engine. While the engine is running, release the parking brake and rise slightly from the seat; the engine should stop.

- Fully depress the brake pedal, set the parking brake, push the PTO switch to OFF and start the engine. Pull the PTO switch to ON. Rise slightly from the seat; the engine should stop.

Gauges and Indicator Lights

The indicator lights (Fig. 16) illuminate when certain controls are activated and when major malfunctions occur that need immediate attention.

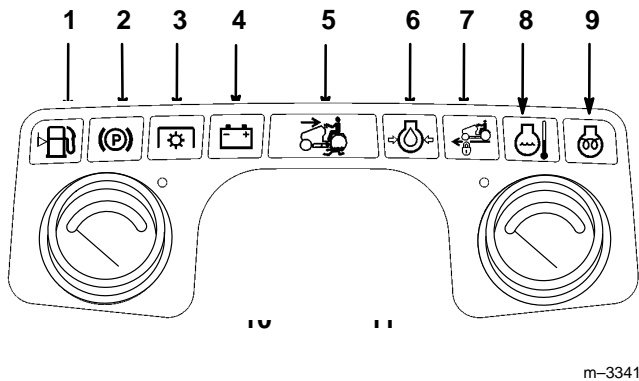

Figure 16

- | | |
|-------------------------------|--------------------------------------|
| 1. Low fuel warning light | 7. Cruise control light |
| 2. Parking brake light | 8. Coolant temperature light |
| 3. PTO (power take off) light | 9. Glow plug indicator light |
| 4. Battery light | 10. Engine coolant temperature gauge |
| 5. Reverse with PTO on light | 11. Fuel gauge |
| 6. Oil pressure light | |

Parking Brake Light

When the parking brake light is ON it indicates the parking brake is set. The machine will not drive while the parking brake is set.

PTO (Power Take Off) Light

When the PTO (power take off) light is ON it indicates the implement is being powered. The PTO clutch must be disengaged before the engine will start.

Battery Light

The battery light will be ON when the key is in the RUN or LIGHTS positions if the battery voltage is below 12.1 volts or above 15.0 volts. If the light comes on at a higher RPM, it is important to have your battery and electrical system checked and the problem corrected.

Flashing Reverse Light

When the reverse light flashes it indicates the PTO is engaged and the tractor is operating in reverse. **When the light is flashing, look behind and use extra caution when backing. Be especially watchful for children and pets.**

Oil Pressure Light

When the oil light is ON it indicates the engine oil pressure is low. After the engine starts the light should go out. When the engine is running, the light comes ON if the oil pressure drops below a safe operating level. If the light comes on while the engine is running, **stop the engine immediately and correct the cause of low oil pressure.**

Cruise Control Light

The cruise control light indicates that the cruise control system is activated.

Coolant Temperature Light

The coolant temperature light shows when the engine cooling system is overheated. The light indicates to check the gauge and follow the cautions, below.

Engine Coolant Temperature Gauge

This gauge shows the coolant temperature in the engine. If the gauge enters the red zone, disengage the PTO and allow the engine to cool while continuing to run the engine.

If the gauge does not show temperatures dropping, **stop the engine immediately, clean the air intake screens, clean the radiator screen, and/or correct the cause of high temperature.**

Glow Plug Indicator Light

The glow plug indicator light comes on when the ignition switch is in the RUN or RUN WITH LIGHTS position but should be out when the engine is running.

Fuel Level Gauge

This gauge shows the level of fuel remaining.

Low Fuel Light

The low fuel light comes on when the fuel level is low.

Hour Meter

The hour meter (Fig. 12) records the amount of time the engine has run. Use it to schedule regular maintenance.

Driving Forward or Backward

1. Stop the tractor.

IMPORTANT: Never attempt to shift gears with the tractor in motion. Internal transmission damage may result.

IMPORTANT: Do not force the shift lever. Applying slight pressure to the traction control pedal while shifting will help the gears engage.

2. Shift into high “H” or low “L” forward speed with the High–Low lever (Fig. 12). Use Low for best mowing performance and smoothest operation with all attachments. Use High for transporting or where conditions permit higher speed.

DANGER

POTENTIAL HAZARD

- Excessive speed on slopes can result in rollover accidents or loss of control.

WHAT CAN HAPPEN

- Rollover accidents or loss of control can result in serious injury or death.

HOW TO AVOID THE HAZARD

- Never shift into neutral while moving.
- Never allow tractor to roll freely in neutral on slopes.
- Read, understand, and follow all instructions in the operator’s manual and on the machine before starting.

3. Place the throttle control in the FAST position for best performance. (The throttle control regulates engine revolutions per minute.)
4. Place your foot on the traction control pedal and slowly press on the top of the pedal to move forward, or on the bottom of the pedal to move backward (Fig. 17). The farther you move the pedal in either direction, the faster the machine will move in that direction.

- To slow down, release the pressure on the traction control pedal and step on the brake pedal.

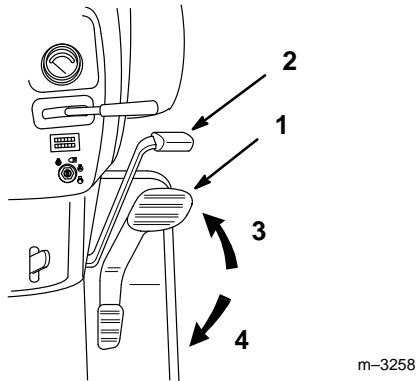

Figure 17

- | | |
|---------------------------|-------------|
| 1. Traction control pedal | 3. Forward |
| 2. Brake pedal | 4. Backward |

m-3258

Stopping the Machine

To stop the machine, release the traction control pedal, step on the brake pedal, disengage the power take off (PTO), lower the attachment lift, and turn the ignition key to STOP. Also set the parking brake if you leave the machine unattended; refer to Setting the Parking Brake, page 15. Remember to remove the key from the ignition switch.

Re-centering the Steering Wheel

The power steering will not always return the steering wheel to the centered position. When this happens, the steering wheel will appear to be un-centered when the front wheels return to the straight-ahead position.

This is not a mechanical problem, but if it happens to your vehicle and you wish to re-center the steering wheel, you may do so:

- Note the degree to which the steering wheel is out of center, then turn the steering wheel all the way in the opposite direction until the front wheels no longer turn.
- Continue turning the steering wheel by the degree to which it is off center.
- Now turn the steering wheel in the other direction until the front wheels aim straight ahead. The steering wheel should now be centered.

CAUTION

POTENTIAL HAZARD

- Someone could move or attempt to operate the tractor while it is unattended.

WHAT CAN HAPPEN

- Children or bystanders may be injured if they use the tractor.

HOW TO AVOID THE HAZARD

- Always remove the ignition key and set the parking brake when leaving the machine unattended, even if just for a few minutes.

Attachment Power Lift

The attachment power lift (Fig. 18) is used to raise and lower attachments.

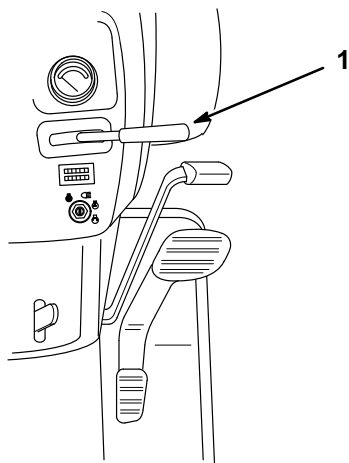

Figure 18

m-3258

1. Attachment power lift

Raising Attachments

1. Start the tractor.
2. Pull the lift lever UP to raise the attachment (Fig. 19). This will lift and hold the attachment in the raised position.

WARNING

POTENTIAL HAZARD

- When the engine is off, attachments in the raised position can gradually lower.

WHAT CAN HAPPEN

- Someone nearby may be pinned or injured by the attachment as it lowers.

HOW TO AVOID THE HAZARD

- Always lower the attachment lift each time you shut off the tractor.

Lowering Attachments

1. Start the tractor.
2. Push the lift lever DOWN to lower the attachment (Fig. 19).

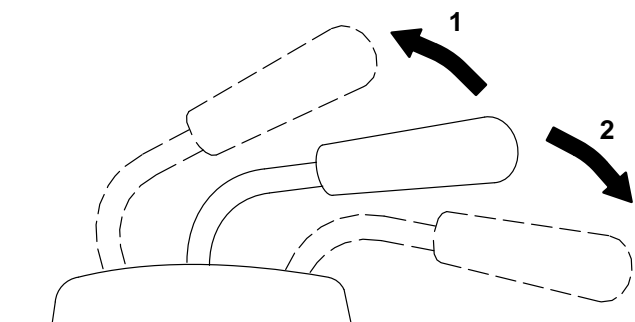

Figure 19

1. Lift lever-Up
2. Lift lever-Down

Positioning the Seat

The seat can move forward and backward. Position the seat where you have the best control of the machine and are most comfortable.

1. To adjust, move the lever sideways to unlock seat (Fig. 20).
2. Slide the seat to the desired position and release the lever to lock the seat into position.

IMPORTANT: Be sure that the seat is locked in position before operating.

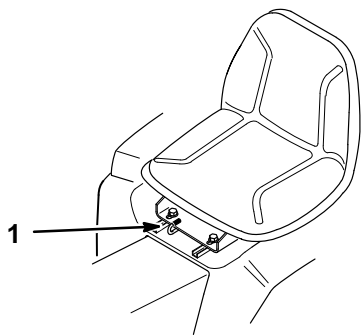

Figure 20

m-3320

1. Adjustment lever
-

Positioning the Tilt Steering Wheel

The steering wheel has four tilt locations. Position the steering wheel where you have the best control of the machine and are most comfortable.

1. Lift the tilt lever to release the lock (Fig. 22).
2. Move the steering wheel to a comfortable position; then release the lever to lock it in place.

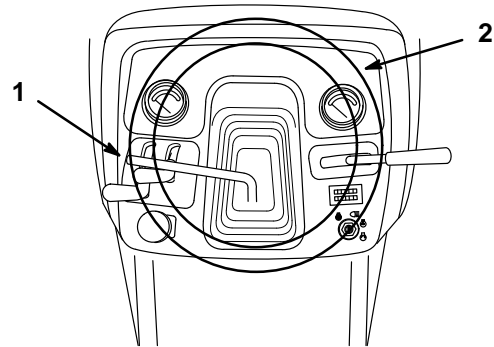

Figure 22

m-3259

1. Tilt lever
 2. Steering wheel
-

Headlights and Taillights

The headlights and taillights are turned on by turning the ignition key to the LIGHTS position. They can be turned on even if the engine is not running. Remove the key when leaving the machine unattended so that the headlights cannot be turned on and discharge the battery.

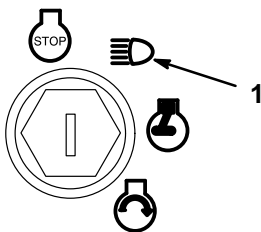

Figure 21

m-3312

1. Lights
-

Using the Cruise Control

The cruise control is a switch (Fig. 23) on the right fender that maintains a set traction control position without foot pressure. The cruise control only operates when moving forward.

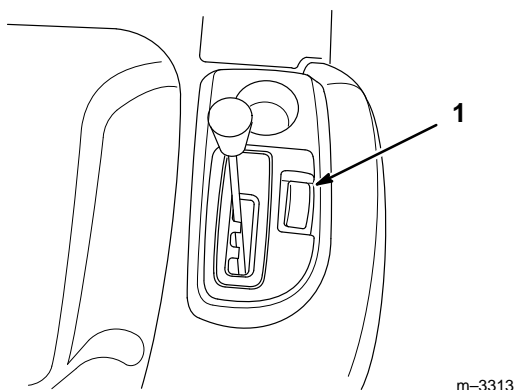

Figure 23

1. Cruise control

Engaging the Cruise Control

1. Begin driving the tractor; refer to Driving Forward or Backward, page 19. While holding your foot steady on the traction control pedal, push the cruise control switch (Fig. 23) to the “SET” position. This locks the traction control in position and your foot can then be removed from the traction control. A constant pedal position will be maintained.
2. The cruise control has a “speed-up” feature: If you initially set it to any speed other than full speed, you can speed up with your foot on the traction pedal for as long as you wish. When you release the traction pedal, the pre-selected cruise speed resumes automatically.

Disengaging the Cruise Control

1. While holding your foot steady on the traction control pedal, move the cruise control switch (Fig. 12) to the “OFF” position.
2. This unlocks the traction control. You must now use the traction control to move forward.
3. For quick stops, just press the brake pedal. This automatically disengages the cruise control and applies the brake at the same time.

IMPORTANT: If you accidentally press the cruise control while the engine is running and you are not moving, the machine will subsequently operate at partial speed in forward and will not operate in reverse.

To correct this situation, press the cruise control switch to “OFF,” or press the brake pedal to disengage the cruise control.

The Smart Turn™ Steering Feature

The Smart Turn™ Steering feature automatically lowers the speed of the tractor in tight turns. The decrease in speed is directly proportional to the sharpness of the turn, up to a maximum speed reduction of 40 percent. This allows you to make turns at higher speeds without having to change the speed control position. After the turn, the original speed is automatically restored.

The Smart Turn™ Steering feature does not affect engine speed.

This system was set at the factory and should not need adjustment.

DANGER

POTENTIAL HAZARD

- Excessive speed when turning can result in rollover accidents.

WHAT CAN HAPPEN

- Rollover accidents can result in serious injury or death.

HOW TO AVOID THE HAZARD

- Do not rely on the Smart Turn™ Steering feature to avoid accidents while turning.
- Do not set the cruise control at higher speeds when operating on uneven terrain or slopes.
- Read, understand, and follow all instructions in the operator's manual and on the machine before starting.

Pushing the Machine by Hand

IMPORTANT: Always push the machine by hand. Never tow the machine because transmission damage may occur.

To Push the Machine

1. Disengage the power take off (PTO) and turn the ignition key to "STOP" to stop the engine.
2. Move the High–Low range lever to the neutral position "N." This allows the rear wheels to turn freely.
3. Place the lever back in High or Low after moving the machine, and set the parking brake.

Maintenance

Service Interval Chart

Service Operation	Each Use	5 Hours	25 Hours	50 Hours	100 Hours	200 Hours	Storage Service
Engine Oil—check level	X						X
Engine Coolant—check level	X						X
Radiator Screen—check for debris*	X						X
Brake—check	X						X
Safety System—check	X						X
(3) Air Intake Screens—clean*	X						X
Engine Area—clean*	X						X
Rear Transaxle Cover—clean*	X						X
Fuel Filter—drain water	X						X
Engine Oil—change				Initial	X		X
Engine Oil Filter—change				Initial		X	X
Tires—check pressure			X				X
Battery—check electrolyte level			X				X
Transaxle—check oil level			X				
Transaxle—change oil				Initial		X	X
Transaxle—change oil filter				Initial		X	X
Power Steering Filter—clean				Initial		X	X
Lubrication				X			X
PTO (Power Take Off) Belt—check tension		Initial		X			X
Engine Air Filter—replace*					X		X
Fan Belt—check					X		X
Radiator and Hoses—inspect						X	X
Chipped Surfaces—paint						X	X
Fuel Filter—replace						X	
Radiator—flush and change coolant (every 400 hours or 2 years)							X
* More often in dusty, dirty conditions							

⚠ CAUTION

POTENTIAL HAZARD

- If you leave the key in the ignition switch, someone could start the engine.

WHAT CAN HAPPEN

- Accidental starting of the engine could seriously injure you or other bystanders.

HOW TO AVOID THE HAZARD

- Set the parking brake and remove the key from the ignition switch before you do any maintenance.

Air Cleaner

Service Interval/Specification

Clean the air filter cartridge after every 25 operating hours. Service it more often (every few hours) if operating conditions are extremely dusty or sandy.

Replace the cartridge after every 100 operating hours, or yearly.

Removing the Air Cleaner Cartridge

1. Unlock the clamps and remove the cover.
2. Remove the cartridge from the air cleaner body.

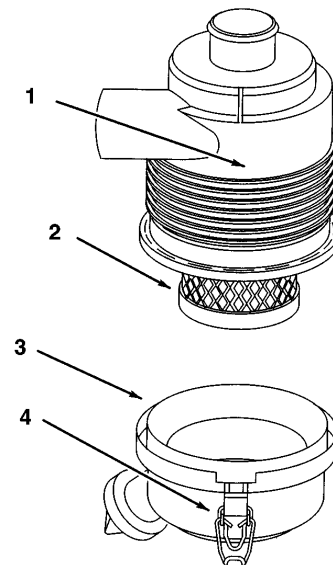

Figure 24

- | | |
|---------------------|-----------|
| 1. Air cleaner body | 3. Cover |
| 2. Cartridge | 4. Clamps |

Cleaning the Air Filter Cartridge

Clean the cartridge by tapping gently on its end with the handle of a screwdriver. Replace the cartridge if it is very dirty or damaged.

Installing the Air Filter Cartridge

1. Install the cartridge in the body.
2. Install the cover and lock the clamps.

Engine Oil

Service Interval/Specification

Change oil:

- After the first 50 operating hours.
- After every 100 operating hours.

Oil Type: High-quality detergent oil classified “API Service CD” or higher for diesel engines. Use no special additives with recommended oils.

Crankcase Capacity: 3.5 quarts (3.3 liters)

Viscosity: See the table below.

USE THESE SAE VISCOSITY OILS

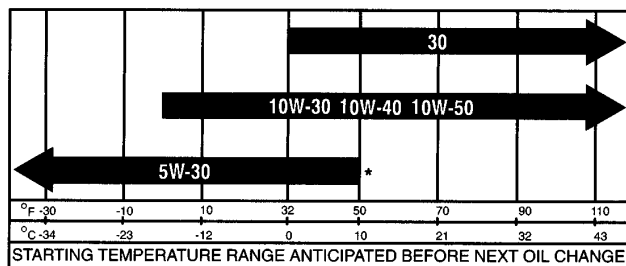

* A synthetic 5W-30 oil may be used.

Changing/Draining the Engine Oil

1. Start the engine and let it run for five minutes. This warms the oil so it drains better.
2. Park the machine so that the drain side is slightly lower than the opposite side to assure the oil drains completely. Then disengage the power take off (PTO), set the parking brake, and turn the ignition key to “STOP” to stop the engine. Remove the key.
3. Open the hood.

CAUTION

POTENTIAL HAZARD

- Components under the hood will be hot if the tractor has been running.

WHAT CAN HAPPEN

- Touching hot components can cause burns.

HOW TO AVOID THE HAZARD

- Allow the tractor to cool before performing maintenance or touching components under the hood.

4. Place a pan below the oil drain. Remove the drain plug and let the oil drain completely (Fig. 25).
5. Install the drain plug and tighten it to 220 in-lbs.

Note: Dispose of the used oil at a certified recycling center.
6. Remove the oil filler cap (Fig. 26) and refill the engine with a high-quality, CD class engine oil (see viscosity chart).

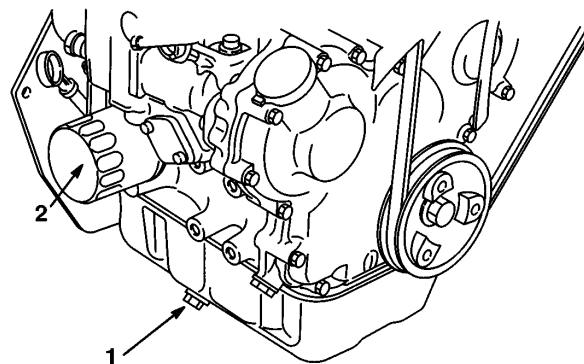

Figure 25

1. Drain plug
2. Oil filter

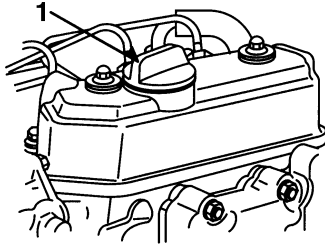

Figure 26

1. Oil filler cap
-

7. Replace the filler cap.
8. Start the engine and let it run at idle for 5 minutes. Then stop the engine.
9. Wait 3 minutes and recheck the oil level. If required, add oil to bring the level to the upper hole on the dipstick. Do not overfill.
10. Check for leaks.

IMPORTANT: Do not overfill the crankcase with oil because this may cause engine damage.

Changing the Engine Oil Filter

Service Interval/Specification

Replace the oil filter after the initial 50 hours of operation and then after every 200 hours.

1. Drain the oil from the engine; refer to Changing/Draining Oil, page 27.
2. Place a drip pan beneath the oil drip tray to receive oil from the oil filter and oil passages in the engine.
3. Turn the filter counterclockwise to remove it.

Note: Dispose of oil filter properly. Recycle in accordance with local codes.

4. Before installing the filter, lightly oil the gasket on the filter with fresh, clean oil. Screw the filter on by hand until the gasket contacts the oil filter adapter. Tighten 1/2 to 3/4 turn more.
5. Remove the oil filler cap and refill the engine with a high-quality, CD class engine oil (see viscosity chart, page 27).
6. Replace the filler cap.
7. Start the engine and let it run at idle for 5 minutes. Then stop the engine.
8. Wait 3 minutes and recheck the oil level. If required, add oil to bring the level to the upper hole on the dipstick. Do not overfill.
9. Check for leaks.

Changing the Engine Coolant

DANGER

POTENTIAL HAZARD

- Coolant is hot and pressurized.

WHAT CAN HAPPEN

- Discharge of hot pressurized coolant can cause severe burns.

HOW TO AVOID THE HAZARD

- Do not remove the radiator cap when the engine is hot. Always allow the engine to cool at least 15 minutes or until the radiator cap is cool enough to touch without burning your hand before removing the radiator cap.

1. Park the machine on a level surface, disengage the power take off (PTO), set the parking brake, lower the attachment lift, and turn the ignition key to “STOP” to stop the engine. Remove the key.
2. Remove the radiator cap and reserve tank cap (Fig. 27).
3. Open both coolant drain valves at the bottom of the radiator and allow coolant to flow into a drain pan. When coolant stops flowing, close the drain valves and dispose of the coolant properly.
4. Slowly fill the radiator with a 50/50 mixture of water and permanent ethylene glycol anti-freeze. Fill the radiator completely. Install the radiator cap.
5. Slowly fill the reserve tank until the level reaches the upper line. DO NOT OVERFILL. Install the reserve tank cap.
6. Start the engine. To properly bleed air from the coolant system, park the tractor on a slope with the rear wheels approximately 6 inches (152 mm) higher than the front wheels. Set the parking brake. Run the engine until it is warm.
7. Park the tractor on a level surface and recheck the coolant level in the reserve tank after the engine has cooled down. Replenish the coolant, if required; refer to Check the Cooling System, page 12.

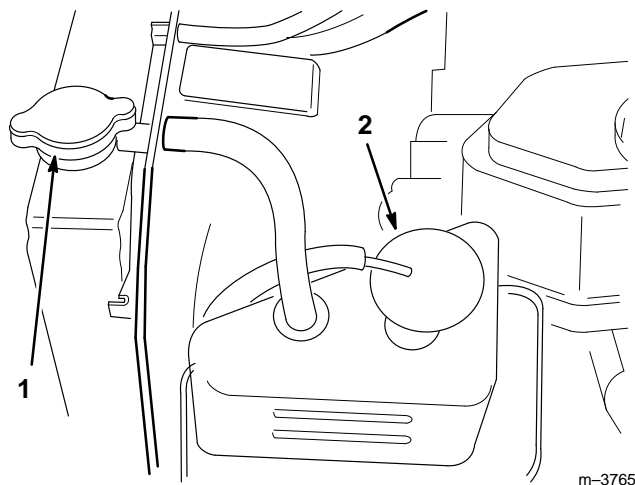

Figure 27

1. Radiator cap
2. Reserve tank cap

Note: If you wish, you can attach a 3/8 ID hose to each of the two drain valves.

Greasing and Lubrication

Service Interval/Specification

Grease the machine after every 50 operating hours or yearly, whichever occurs first. Grease more frequently when operating conditions are extremely dusty or sandy.

Grease Type: General-purpose grease.

How to Grease

1. Disengage the power take off (PTO), set the parking brake, lower the attachment lift, and turn the ignition key to “STOP” to stop the engine. Remove the key.
2. Clean the grease fittings with a cloth. Make sure to scrape off any paint from the front of the fitting(s).
3. Connect a grease gun to the fitting. Pump grease into the fittings until grease begins to ooze out of the bearings.
4. Wipe up any excess grease.

Where to Add Grease

1. Lubricate the left-hand and right-hand spindles until grease begins to ooze out of the bearings (Fig. 28).
2. Lubricate the front axle pivot (Fig. 28).

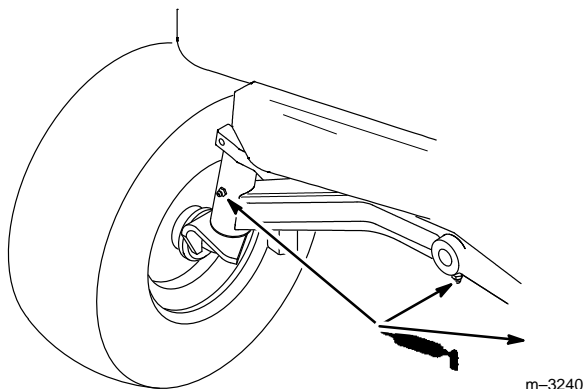

Figure 28

3. Open the drive shaft maintenance cover on the tractor tunnel near the seat by unscrewing the two screws securing it, then raising it (Fig. 29).

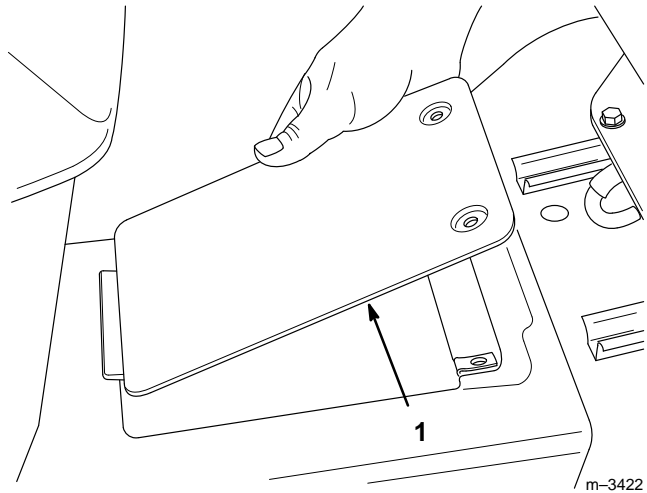

Figure 29

1. Drive shaft maintenance cover

DANGER

POTENTIAL HAZARD

- Rotating shaft can cause injury.

WHAT CAN HAPPEN

- Fingers, hands, feet, hair, etc. can get caught by shaft.
- Loose clothing can get caught by shaft.

HOW TO AVOID THE HAZARD

- Do not operate the tractor without the drive shaft cover in place.
- Keep hands and arms clear of rotating shaft.

- Lubricate the three grease fittings (Fig. 30).

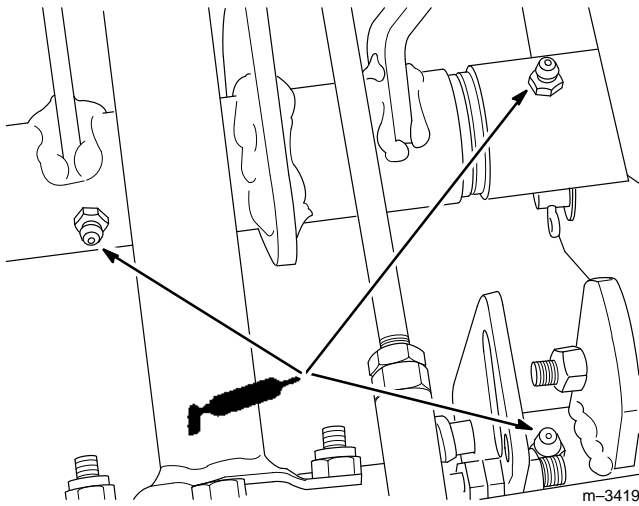

Figure 30

- Replace and secure the cover.
- Grease the fitting on the brake pedal (Fig. 31).

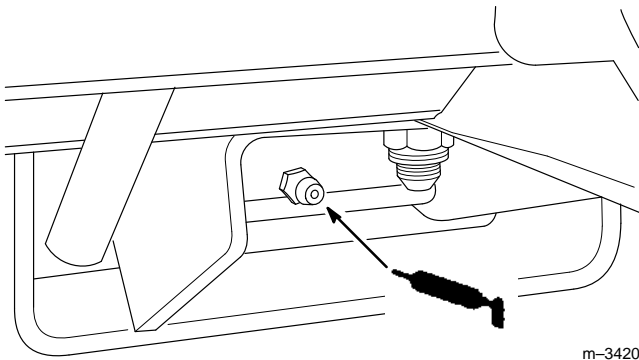

Figure 31

Tire Pressure

Service Interval/Specification

Maintain the air pressure in the front and rear tires as specified. Check the pressure at the valve stem after every 25 operating hours or monthly, whichever occurs first (Fig. 32). Check the tires when they are cold to get the most accurate pressure reading.

Pressure: 12 psi (.85 kPa) front and rear

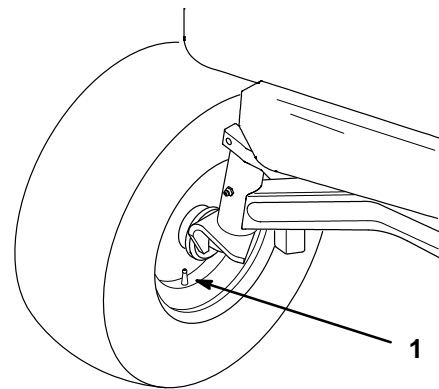

Figure 32

- Valve stem

Brake

Always set the parking brake when you stop the machine or leave it unattended. Check the brake before each use. If the parking brake does not hold securely, an adjustment is required.

Checking the Brake

1. Park the machine on a level surface, disengage the power take off (PTO), put the High-Low range lever in "N," set the parking brake, and turn the ignition key to "STOP" to stop the engine. Remove the key.
2. The rear wheels must lock and skid when you try to push the tractor forward. Adjustment is required if the wheels turn and do not lock; refer to Adjusting the Brake.

Adjusting the Brake

The brake adjustment is behind the left side cover (Fig. 34). If the parking brake does not hold securely, an adjustment is required.

1. Check the brake before you adjust it; refer to Checking the Brake.
2. Place the transmission in neutral.
3. Depress the brake pedal. There should be 2" (51 mm) of free travel (Fig. 33) before the brake begins to engage.

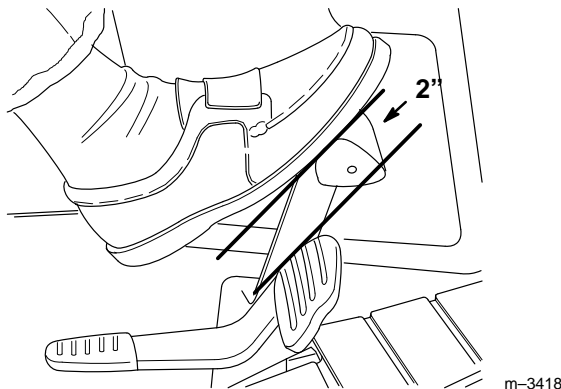

Figure 33

4. Turn the brake adjustment nut (Fig. 34) until there is 2" (51 mm) of free travel.

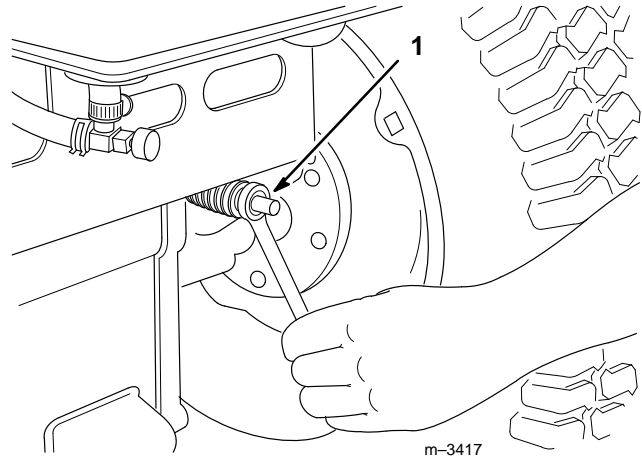

Figure 34

1. Brake adjustment nut

IMPORTANT: Do not overtighten the adjustment nut.

IMPORTANT: With the parking brake released, the rear wheels must rotate freely when you push the tractor. If brake action and free wheel rotation cannot be achieved, contact your Authorized Service Dealer immediately.

Fuel Tank

Draining the Fuel Tank

DANGER

POTENTIAL HAZARD

- In certain conditions fuel is extremely flammable and highly explosive.

WHAT CAN HAPPEN

- A fire or explosion from fuel can burn you, others, and cause property damage.

HOW TO AVOID THE HAZARD

- Drain fuel from the fuel tank when the engine is cold. Do this outdoors in an open area. Wipe up any fuel that spills.
- Never drain fuel near an open flame or where fuel fumes may be ignited by a spark.
- Never smoke a cigarette, cigar or pipe near the tractor.

1. Park the machine on a level surface to assure the fuel tank drains completely. Then disengage the power take off (PTO), set the parking brake, lower the attachment lift, and turn the ignition key to "STOP" to stop the engine. Remove the key.
2. Close the fuel shut-off valve at the fuel tank (Fig. 35 & 36).

IMPORTANT: Do NOT run the engine until it uses up all of the fuel and stops. The fuel injector pump on the engine requires fuel for lubrication.

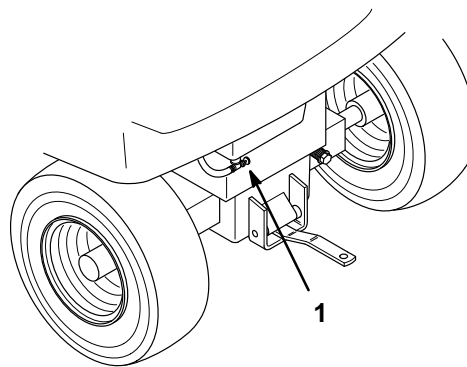

m-3263

Figure 35

1. Fuel shut-off valve

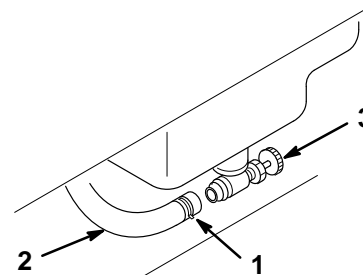

m-2487

Figure 36

1. Hose clamp
2. Fuel line
3. Fuel shut-off valve

3. Loosen the hose clamp and slide it up the fuel line away from the fuel shut-off valve (Fig. 36).
4. Pull the fuel line off the fuel shut-off valve (Fig. 36). Some fuel will flow out from the hose as it is disconnected from the valve. Attach a 5/16 ID hose to the valve to help drain the fuel into a container. Open the valve and allow fuel to drain into a fuel can or drain pan. Dispose of fuel properly.

IMPORTANT: Do not turn or unscrew the fuel shut-off valve.

5. Install the fuel line onto the fuel shut-off valve. Slide the hose clamp close to the valve to secure the fuel line (Fig. 36). The fuel shut-off valve should normally be left open, except for service on the fuel system or when the tractor is transported on a trailer.

Fuel Filter

Service Interval/Specification

Replace the fuel filter after every 200 operating hours.

Replacing the Fuel Filter

1. Disengage the power take off (PTO), set the parking brake, lower the attachment lift, and turn the ignition key to “STOP” to stop the engine. Remove the key.
2. Close the fuel shut-off valve at the fuel tank (Fig. 35 & 36).
3. Open the hood.
4. Drain the fuel from the fuel filter into a suitable container and dispose of it properly.
5. Remove the fuel filter with a wrench and clean the mounting surface.
6. Lubricate the gasket on the new filter with clean engine oil. Screw on the new filter by hand until the gasket contacts the housing. Then tighten it another 1/2 turn.
7. Open the fuel shut-off valve at the fuel tank (Fig. 35 & 36).
8. Start the engine and check for leaks.

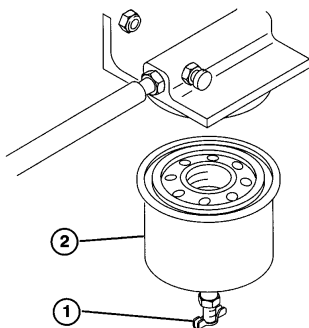

Figure 37

1. Fuel filter drain valve
2. Fuel filter canister

Front Wheel Toe-In

Service Interval/Specification

Maintaining correct front wheel toe-in is important for safety, Smart Turn™ Steering operation and ease of use. If uneven tire wear, lawn scuffing or hard steering develop, adjustment may be required. Check the toe-in after every 100 operating hours or once a year, whichever occurs first (Fig. 38).

Maintain the following specification: 1/8–1/4 inch (3.5–6.5 mm) toe-in on the front wheels.

Measuring Toe-In

1. Disengage the power take off (PTO), set the parking brake, lower the attachment lift, and turn the ignition key to “STOP” to stop the engine. Remove the key.
2. Turn the wheels straight ahead.
3. Push the front of the tires out to remove normal looseness in the linkage.
4. Measure the distance between both of the front tires at spindle level (at the front and rear of the wheels) (Fig. 38).
5. The front measurement should be 1/8” to 1/4” (3 to 6 mm) less than the rear measurement. If adjustment is needed, follow the instructions in Adjusting Toe-In, page 35.

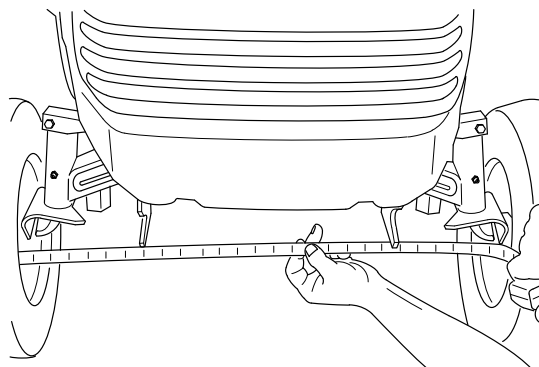

m-3421

Figure 38

- If the oil level is low, slowly pour only enough SAE 10W–30 detergent oil into the filler tube to raise the level to the FULL line.

IMPORTANT: Do not fill above the FULL line as fluid may overflow.

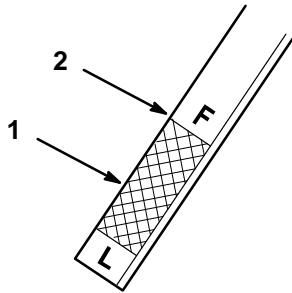

Figure 42

- Operating range
 - FULL line
-

Changing Transaxle Oil

Replace the transaxle fluid at 50 hours initially, then every 200 hours thereafter.

Fluid Type: SAE 10W–30 Detergent oil (API service SG, SH or above)

Transaxle Capacity:

Total system capacity: 7.0 qts.

Approximate refill capacity: 4.5 qts.

- Warm up the transaxle oil by driving the tractor.
- Park the machine on a level surface to assure the oil drains completely. Then turn off the power take off (PTO), set the parking brake, lower the attachment lift, and turn the ignition key to “STOP” to stop the engine. Remove the key.
- Place a pan below the transaxle drain. Open the drain by removing the plug (Fig. 43).
- When the oil has drained completely, install the plug.

Note: Dispose of the used oil at a certified recycling center.

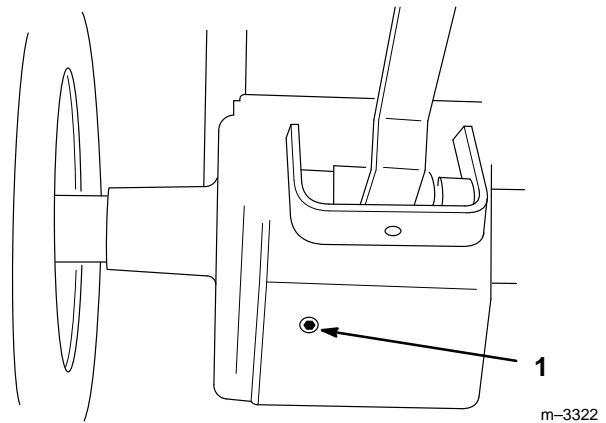

Figure 43

- Transaxle drain plug
-

- Change the transaxle filter; refer to Changing the Transaxle Filter, page 37.
- Slowly pour the specified refill capacity of oil into the filler tube (Fig. 41).
- Start the engine, let it run for 30 seconds at high idle, and cycle the steering wheel several times to fill the filter and hydraulic lines. Then shut off the engine.
- Now check the fluid level; refer to Checking Transaxle Fluid Level, page 35. Slowly add additional oil to bring the oil level to the FULL mark on the dipstick.

Changing the Transaxle Filter

Service Interval/Specification

Replace the transaxle filter after the first 50 hours; then every 200 hours.

1. Drain the oil from the transaxle; refer to Changing/Draining Transaxle Fluid, page 36.
2. Remove the transaxle filter and wipe the filter adapter (Fig. 44) gasket surface.
3. Apply a thin coat of new oil to the rubber gasket on the replacement filter (Fig. 44).

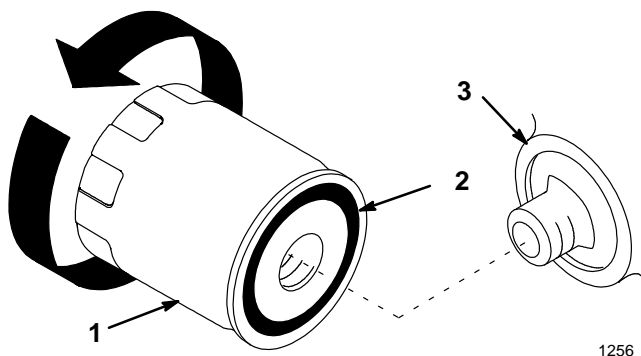

Figure 44

1. Transaxle filter
2. Gasket
3. Adapter

4. Install the replacement transaxle filter to the filter adapter. Turn the filter clockwise until the rubber gasket contacts the filter adapter, then tighten the filter an additional 3/4 turn (Fig. 44).
5. Fill the transaxle with the proper type of new oil; refer to Changing/Draining Transaxle Fluid, page 36.

Cleaning the Power Steering Filter

The power steering filter should be cleaned initially at 50 hours, then at 200-hour intervals thereafter. Please have your Authorized Service Dealer clean the filter.

Fuses

Service Interval/Specification

The electrical system is protected by fuses. They require no maintenance. However, if a fuse blows, check the component and circuit for a malfunction or short. To replace a fuse, pull it out of the fuse box (Fig. 45).

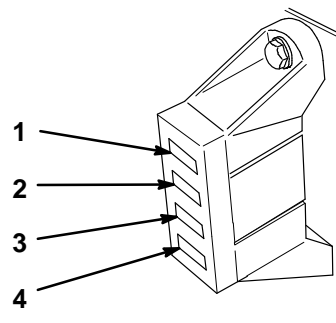

m-3316

Figure 45

1. F1; main-30 amp
2. F2; glow plug timer and start circuits-15 amp
3. F3; dash, interlock, and cruise control-10 amp
4. F4; headlights and taillights-10 amp

Headlights

Specification: Bulb # 1156 Automotive Type

Removing the Bulb

1. Disengage the power take off (PTO), set the parking brake, lower the attachment lift, and turn the ignition key to "STOP" to stop the engine. Remove the key.
2. Open the hood. Pull the wire connectors off both bulb holder terminals.
3. Rotate the bulb holder 1/4 turn counterclockwise and remove it from the reflector (Fig. 46).
4. Push and rotate the bulb counterclockwise until it stops (approx. 1/4 turn) and remove the bulb from the bulb holder (Fig. 47).

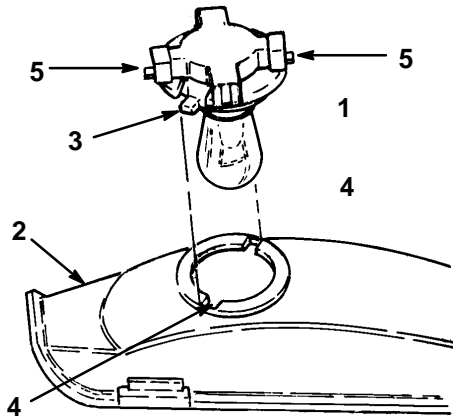

Figure 46

- | | |
|----------------|--------------|
| 1. Bulb holder | 4. Slots |
| 2. Reflector | 5. Terminals |
| 3. Tabs | |

Installing the Bulb

1. The bulb has metal pins on the side of its base. Align the pins with the slots in the bulb holder and insert the base into the holder (Fig. 47). Push and rotate the bulb clockwise until it stops.

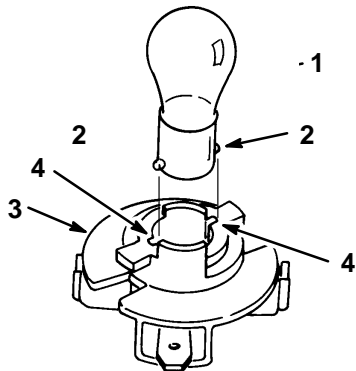

Figure 47

- | | |
|---------------|----------------|
| 1. Bulb | 3. Bulb holder |
| 2. Metal pins | 4. Slots |

2. The bulb holder has two tabs (Fig. 46). Align the tabs with the slots in the reflector, insert the bulb holder into the reflector and rotate it 1/4 turn clockwise until it stops.
3. Push the wire connectors onto the terminals on the bulb holder.

Taillights

Bulb: GE 193

Removing the Bulb

1. Disengage the power take off (PTO), set the parking brake, lower the attachment lift, and turn the ignition key to "STOP" to stop the engine. Remove the key.
2. Remove the two screws.
3. Pull the lens out far enough so that you can remove the bulb socket.
4. Pull the bulb from the socket.

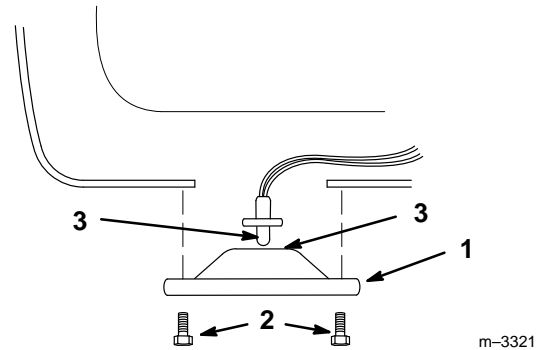

Figure 48

- | | |
|-----------|-----------|
| 1. Lens | 3. Bulb |
| 2. Screws | 4. Socket |

Installing the Bulb

Reverse the bulb removal procedure.

Battery

Service Interval/Specification

Check the electrolyte level in the battery every 25 hours. Always keep the battery clean and fully charged. Use a paper towel to clean the battery case. If the battery terminals are corroded, clean them with a solution of four parts water and one part baking soda. Apply a light coating of grease to the battery terminals to prevent corrosion.

Battery size: 12 v, 495 Cold Cranking Amps at 0° F.
Group size 45.

Checking the Electrolyte Level

1. Park the machine on a level surface. Disengage the power take off (PTO), set the parking brake, lower the attachment lift, and turn the ignition key to “STOP” to stop the engine. Remove the key.
2. Open the hood.

CAUTION

POTENTIAL HAZARD

- Components under the hood will be hot if the tractor has been running.

WHAT CAN HAPPEN

- Touching hot components can cause burns.

HOW TO AVOID THE HAZARD

- Allow the tractor to cool before performing maintenance or touching components under the hood.

3. Lift off the cell cover to see into the cells. The electrolyte must be up to the lower part of the tube (Fig. 49). Do not allow the electrolyte to get below the plates.
4. If the electrolyte is low, add the required amount of distilled water; refer to Adding Water to the Battery.

5. If the fluid level is correct, press the cell cover onto the battery.

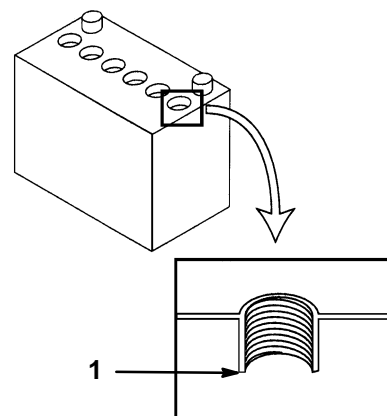

Figure 49

1. Lower part of the battery cell tube

Adding Water to the Battery

IMPORTANT: Use only distilled water.

The best time to add distilled water to the battery is just before you operate the machine. This lets the water mix thoroughly with the electrolyte solution.

1. Clean the top of the battery with a paper towel.
2. Lift off the cell cover (Fig. 49).
3. Slowly pour distilled water into each battery cell until the level is up to the lower part of the tube (Fig. 49).

IMPORTANT: Do not overfill the battery because electrolyte (sulfuric acid) can cause severe corrosion and damage to the chassis.

4. Press the cell cover onto the battery.

Removing the Battery

1. Disengage the power take off (PTO), set the parking brake, lower the attachment lift, and turn the ignition key to “STOP” to stop the engine. Remove the key.
2. Open the hood.
3. Remove the battery hold-down brackets (Fig. 50).
4. Disconnect the negative (black) ground cable from the battery post (Fig. 50).
5. Disconnect the positive (red) cable from the battery post (Fig. 50).
6. Remove the battery by lifting it up and out of the engine compartment.

IMPORTANT: Always hold the battery vertical to avoid spilling battery acid.

WARNING

POTENTIAL HAZARD

- The battery terminals could short against the metal tractor components.

WHAT CAN HAPPEN

- Sparks can cause the battery gasses to explode.

HOW TO AVOID THE HAZARD

- When removing or installing the battery, do not allow the battery terminals to touch any metal parts of the tractor.
- Always keep the battery hold-down brackets in place to secure the battery.

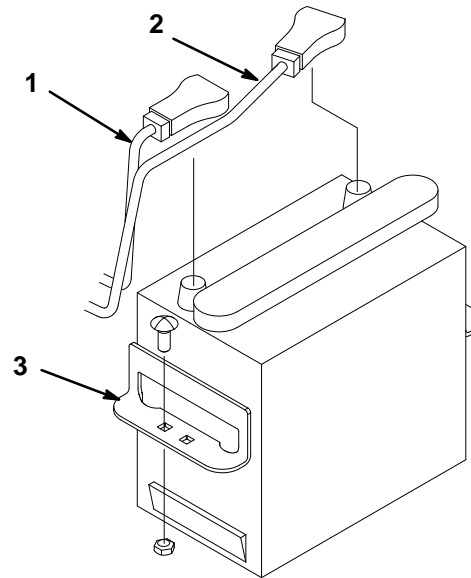

m-3766

Figure 50

1. Negative cable (black)
2. Positive cable (red)
3. Hold-down bracket

Installing the Battery

1. Place the battery onto the chassis (Fig. 50).
2. Install the battery hold-down brackets.
3. Connect and tighten the positive (red) cable to the positive (+) battery post (Fig. 50).
4. Connect and tighten the negative (black) cable to the negative (-) battery post (Fig. 50).

Charging the Battery

IMPORTANT: Always keep the battery fully charged (1.260 specific gravity). This is especially important to prevent battery damage when the temperature is below 32°F (0°C).

1. Remove the battery from the chassis; refer to Removing the Battery, page 40.
2. Check the electrolyte level; refer to Checking the Electrolyte Level, page 39, steps 2–4.
3. Remove the cell cover from the battery and connect a 3– to 4–amp battery charger to the battery posts. Charge the battery at a rate of 4 amperes or less for 4 hours (12 volts). Do not overcharge the battery. Install the cell cover after the battery is fully charged.

WARNING

POTENTIAL HAZARD

- Charging the battery produces gasses.

WHAT CAN HAPPEN

- Battery gasses can explode.

HOW TO AVOID THE HAZARD

- Keep cigarettes, sparks and flames away from battery.

4. Install the battery in the chassis; refer to Installing the Battery, page 40.

Wiring Diagram

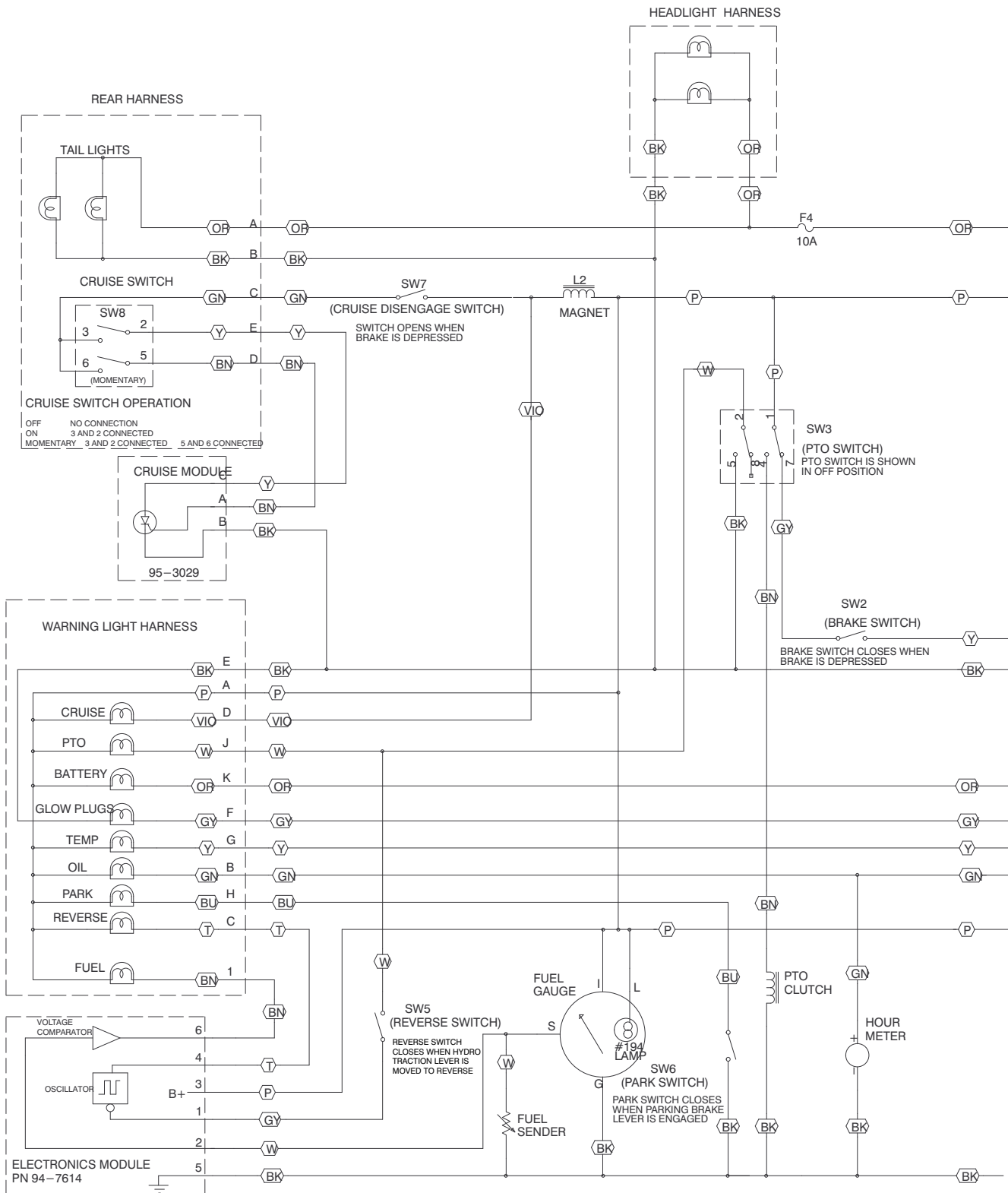

Wiring Diagram

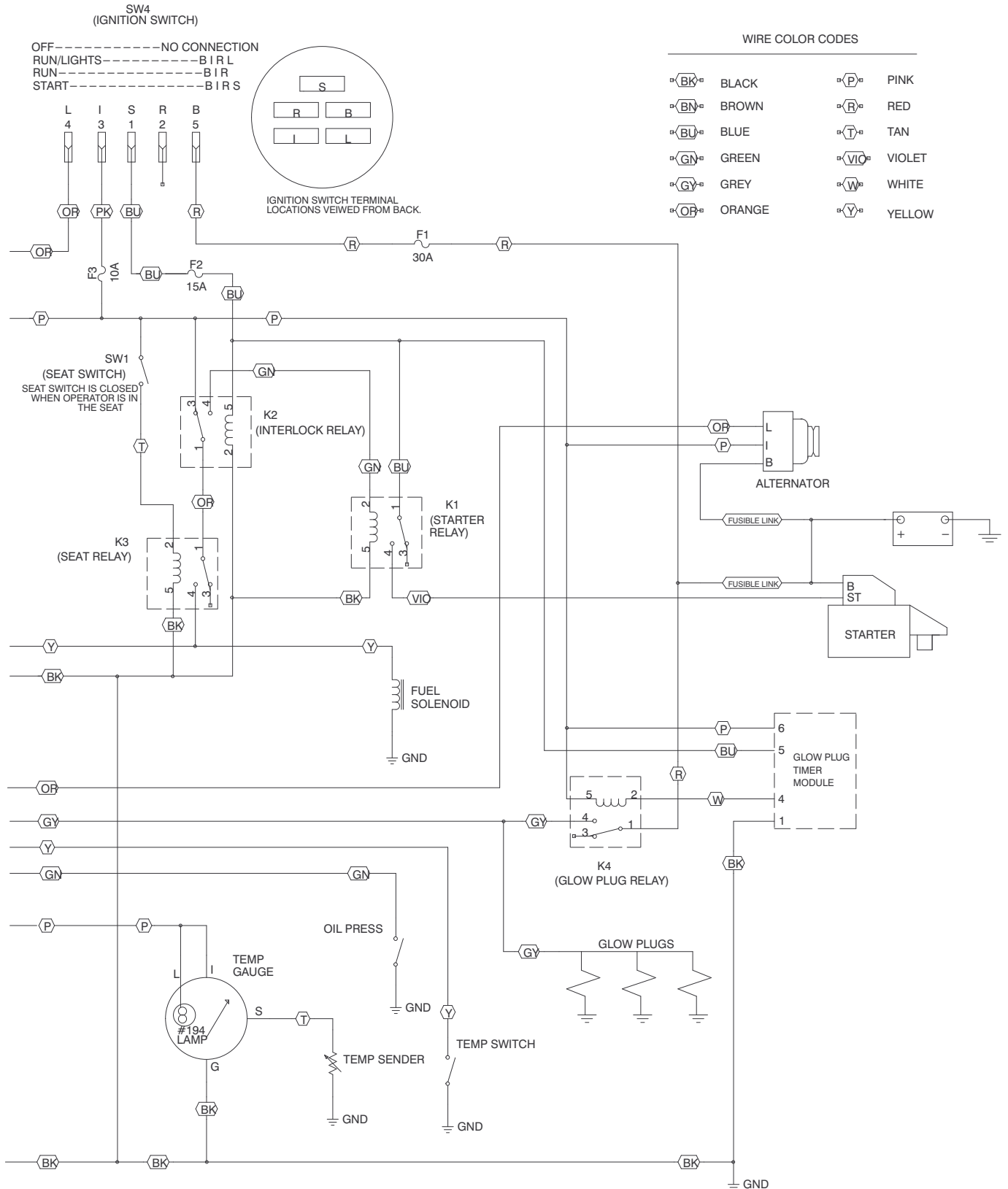

Cleaning and Storage

1. Disengage the power take off (PTO), set the parking brake, and turn the ignition key to “STOP” to stop the engine. Remove the key.
2. Remove grass clippings, dirt, and grime from the external parts of the entire machine, especially the engine. Clean debris from the (3) air intake screens, the radiator screen, and the rear transaxle cover; refer to Check for Debris, page 13.

IMPORTANT: You can wash the machine with mild detergent and water. DO NOT PRESSURE WASH THE MACHINE. Pressure washing may damage the electrical system or wash away necessary grease at friction points. Avoid excessive use of water, especially near the control panel, lights, engine, and the battery.

3. Perform all of the service operations that are required for storage; refer to Service Interval Chart, page 25.
4. Remove the battery from the chassis, check the electrolyte level, and charge it fully; refer to Battery, page 39. Do not connect the battery cables to the battery posts during storage.

IMPORTANT: The battery must be fully charged to prevent it from freezing and being damaged at temperatures below 32°F (0°C). A fully charged battery maintains its charge for about 50 days at temperatures lower than 40°F (4°C). If the temperatures will be above 40°F (4°C), check the water level in the battery and charge it every 30 days.

5. For long-term storage (more than 90 days) drain the fuel tank; refer to Draining the Fuel Tank, page 33. Dispose of fuel properly. Recycle in accordance with local codes.

IMPORTANT: Do NOT run the engine until it uses up all of the fuel and stops. The fuel injector pump on the engine requires fuel for lubrication.

6. Check and tighten all bolts, nuts, and screws. Repair or replace any part that is damaged or defective.
7. Paint all scratched or bare metal surfaces. Paint is available from your Authorized Service Dealer.
8. Store the machine in a clean, dry garage or storage area. Remove the key from the ignition switch and keep it in a memorable place. Cover the machine to protect it and keep it clean.

Troubleshooting

PROBLEM	POSSIBLE CAUSES	CORRECTIVE ACTION
The starter does not crank.	<ol style="list-style-type: none"> 1. The PTO is ON. 2. The brake is not depressed or the parking brake is not on. 3. The operator is not seated. 4. The electrical connections are corroded or loose. 5. A fuse is blown or loose. 6. The relay or switch is defective. 7. The battery is discharged. 8. The safety interlock system is malfunctioning. 9. A faulty starter or starter solenoid. 10. Seized internal engine components. 	<ol style="list-style-type: none"> 1. Move the PTO to OFF. 2. Set the parking brake. 3. Sit on the seat. 4. Check the electrical connections for good contact. 5. Correct or replace the fuse. 6. Contact your Authorized Service Dealer. 7. Charge the battery or replace it. 8. Contact your Authorized Service Dealer. 9. Contact your Authorized Service Dealer. 10. Contact your Authorized Service Dealer.
The engine cranks, but will not start.	<ol style="list-style-type: none"> 1. Incorrect starting procedure. 2. The fuel tank is empty. 3. The fuel shut-off valve is closed. 4. Dirt, water, stale fuel, or incorrect fuel is in the fuel system. 5. Clogged fuel line. 6. The kill relay is not energized, or the fuel solenoid is inoperative. 7. There is air in the fuel 8. Inoperative glow plugs. 	<ol style="list-style-type: none"> 1. Refer to Starting and Stopping the Engine, page 16. 2. Fill with fresh fuel. 3. Open the fuel shut-off valve. 4. Drain and flush the fuel system; add fresh fuel. 5. Clean or replace. 6. Contact your Authorized Service Dealer. 7. Bleed the nozzles and check for air leaks at the fuel hose connections and fittings between the fuel tank and engine. 8. Check the fuse, glow plugs and wiring.

PROBLEM	POSSIBLE CAUSES	CORRECTIVE ACTION
<p>The engine cranks, but will not start (continued).</p>	<ol style="list-style-type: none"> 9. Slow cranking speed. 10. The air cleaner element is dirty. 11. Low compression. 12. The injection nozzles are faulty. 13. The fuel filter is clogged. 14. The injection pump timing is incorrect. 15. The injection pump is faulty. 16. Improper fuel grade for cold weather use. 	<ol style="list-style-type: none"> 9. Check the battery, oil viscosity and starting motor (contact your Authorized Service Dealer). 10. Clean or replace. 11. Contact your Authorized Service Dealer. 12. Contact your Authorized Service Dealer. 13. Replace the fuel filter. 14. Contact your Authorized Service Dealer. 15. Contact your Authorized Service Dealer. 16. Drain the fuel system and replace the fuel filter. Add fresh fuel of proper grade for ambient temperature conditions.
<p>The engine starts, but does not keep running.</p>	<ol style="list-style-type: none"> 1. The fuel tank vent is restricted. 2. Dirt or water is in the fuel system. 3. The fuel filter is clogged. 4. The fuel pump is faulty. 5. There is air in the fuel. 6. Improper fuel grade for cold weather use. 	<ol style="list-style-type: none"> 1. Contact your Authorized Service Dealer. 2. Drain and flush the fuel system; add fresh fuel. 3. Replace the fuel filter. 4. Contact your Authorized Service Dealer. 5. Bleed the nozzles and check for air leaks at fuel hose connections and fittings between the fuel tank and engine. 6. Drain the fuel system and replace the fuel filter. Add fresh fuel of proper grade for ambient temperature conditions.
<p>The engine runs, but knocks or misses.</p>	<ol style="list-style-type: none"> 1. Dirt, water, stale fuel, or incorrect fuel is in the fuel system. 2. Engine overheating. 	<ol style="list-style-type: none"> 1. Drain and flush the fuel system; add fresh fuel. 2. See ENGINE OVERHEATS.

PROBLEM	POSSIBLE CAUSES	CORRECTIVE ACTION
The engine runs, but knocks or misses (continued).	<ol style="list-style-type: none"> 3. There is air in the fuel. 4. The injection nozzles are faulty. 5. Low compression 6. The injection pump timing is incorrect. 7. Excessive carbon build-up. 8. Internal wear or damage. 	<ol style="list-style-type: none"> 3. Bleed nozzles and check for air leaks at the fuel hose connections and fittings between the fuel tank and engine. 4. Contact your Authorized Service Dealer. 5. Contact your Authorized Service Dealer. 6. Contact your Authorized Service Dealer. 7. Contact your Authorized Service Dealer. 8. Contact your Authorized Service Dealer.
The engine will not idle.	<ol style="list-style-type: none"> 1. The fuel tank vent is restricted. 2. Dirt, water, stale fuel, or incorrect fuel is in the fuel system. 3. The idle speed adjusting screw is incorrectly set. 4. The fuel pump is faulty. 5. Low compression. 6. The air cleaner element is dirty. 7. The fuel filter is clogged. 8. There is air in the fuel. 	<ol style="list-style-type: none"> 1. Contact your Authorized Service Dealer. 2. Drain and flush the fuel system; add fresh fuel. 3. Contact your Authorized Service Dealer. 4. Contact your Authorized Service Dealer. 5. Contact your Authorized Service Dealer. 6. Clean or replace. 7. Replace the fuel filter. 8. Bleed the nozzles and check for air leaks at the fuel hose connections and fittings between the fuel tank and engine.
The engine overheats.	<ol style="list-style-type: none"> 1. More coolant is needed. 2. (3) air intake screens are dirty. 3. Restricted air flow to the radiator. 4. The crankcase oil level is incorrect. 5. Excessive loading. 	<ol style="list-style-type: none"> 1. Check and add coolant. 2. Clean with every use. 3. Inspect and clean the radiator screen with every use. 4. Fill or drain to the full mark. 5. Reduce load; use lower ground speed.

PROBLEM	POSSIBLE CAUSES	CORRECTIVE ACTION
The engine overheats (continued).	<ol style="list-style-type: none"> 6. The thermostat is faulty. 7. The fan belt is loose or broken. 8. Incorrect fuel is in the fuel system. 9. Injection timing is incorrect. 10. Coolant pump is defective. 	<ol style="list-style-type: none"> 6. Contact your Authorized Service Dealer. 7. Contact your Authorized Service Dealer. 8. Drain and flush the fuel system; add fresh fuel. 9. Contact your Authorized Service Dealer. 10. Contact your Authorized Service Dealer.
The engine loses power.	<ol style="list-style-type: none"> 1. The crankcase oil level is incorrect. 2. The air cleaner element is dirty. 3. Dirt, water, stale fuel, or incorrect fuel is in the fuel system. 4. The engine is overheated. 5. Low compression. 6. The fuel tank vent is restricted. 7. The engine load is excessive. 8. There is air in the fuel. 9. The injection pump timing is incorrect. 10. The injection pump is faulty. 	<ol style="list-style-type: none"> 1. Fill or drain to the full mark. 2. Clean or replace. 3. Drain and flush the fuel system; add fresh fuel. 4. See ENGINE OVERHEATS. 5. Contact your Authorized Service Dealer. 6. Contact your Authorized Service Dealer. 7. Reduce ground speed. 8. Bleed the nozzles and check for air leaks at the fuel hose connections and fittings between the fuel tank and engine. 9. Contact your Authorized Service Dealer. 10. Contact your Authorized Service Dealer.
Excessive black smoke from exhaust.	<ol style="list-style-type: none"> 1. The air cleaner element is dirty. 2. The injection pump timing is incorrect. 3. Incorrect fuel is in the fuel system. 4. The injection nozzles are faulty. 5. The injection pump is faulty. 	<ol style="list-style-type: none"> 1. Clean or replace. 2. Contact your Authorized Service Dealer. 3. Drain the fuel system and refill with specified fuel. 4. Contact your Authorized Service Dealer. 5. Contact your Authorized Service Dealer.

PROBLEM	POSSIBLE CAUSES	CORRECTIVE ACTION
Excessive black smoke from exhaust (continued).	6. Excessive loading.	6. Reduce load; use lower ground speed.
Excessive white smoke from exhaust.	1. The engine temperature is low. 2. The glow plugs are inoperative. 3. The fuel injection nozzles are faulty. 4. The injection pump timing is incorrect. 5. Low compression.	1. Check the thermostat. 2. Check the fuse, glow plugs and wiring. 3. Contact your Authorized Service Dealer. 4. Contact your Authorized Service Dealer. 5. Contact your Authorized Service Dealer.
The tractor will not operate in either direction because the engine bogs down or stalls.	1. The brake is sticking.	1. Contact your Authorized Service Dealer.
The tractor goes forward only at partial speed and is slow or does not operate in reverse.	1. The cruise control was engaged when the traction pedal was in neutral. 2. The engine is running at partial speed. 3. The linkage is out of adjustment. 4. There is internal hydro wear.	1. Turn the cruise control off. 2. Move the throttle to "FAST." 3. Contact your Authorized Service Dealer. 4. Contact your Authorized Service Dealer.
The tractor will not operate in either direction.	1. The High–Low range lever is in "N." 2. The transmission oil is low. 3. The transmission is faulty. 4. The control linkage needs adjustment or replacement. 5. The parking brake was not released or the parking brake is not releasing. 6. The drive shaft or wheel hub key has been damaged. 7. The power steering filter is dirty.	1. Move the High–Low range lever to "L" or "H." 2. Fill to the full "F" mark on the transmission oil dipstick when the transmission is cold. 3. Contact your Authorized Service Dealer. 4. Contact your Authorized Service Dealer. 5. Release the parking brake or check the linkage. 6. Contact your Authorized Service Dealer. 7. Contact your Authorized Service Dealer.

PROBLEM	POSSIBLE CAUSES	CORRECTIVE ACTION
The tractor operates erratically.	<ol style="list-style-type: none"> 1. The transmission oil level is low. 2. The transmission control linkage needs adjustment or replacement. 3. The transmission is faulty. 	<ol style="list-style-type: none"> 1. Fill to the full "F" mark on the transmission oil dipstick when the transmission is cold. 2. Contact your Authorized Service Dealer. 3. Contact your Authorized Service Dealer.
The tractor operates in both directions, but with a loss of power. This condition becomes worse as the transmission becomes hot.	<ol style="list-style-type: none"> 1. The transmission oil level is low. 2. The transmission shows signs of overheating or water contamination. 3. The cooling fan and/or transmission cooling fins are faulty or dirty. 4. The engine is not operating at full throttle. 5. The power steering filter is dirty. 	<ol style="list-style-type: none"> 1. Fill to the full "F" mark on the transmission oil dipstick when the transmission is cold. 2. Replace the transmission oil and filter. 3. Clean the transmission and/or replace the fan (contact your Authorized Service Dealer). 4. Increase the engine speed to full throttle. 5. Contact your Authorized Service Dealer.
The front wheels do not turn with the steering wheel.	<ol style="list-style-type: none"> 1. Air in the hydraulic system. 	<ol style="list-style-type: none"> 1. With the engine running at full throttle, operate the lift and turn the steering wheel back and forth several times.
The steering is noisy.	<ol style="list-style-type: none"> 1. The power steering filter is dirty. 	<ol style="list-style-type: none"> 1. Contact your Authorized Service Dealer.
Abnormal vibration or noise.	<ol style="list-style-type: none"> 1. The engine mounting bolts are loose. 2. The idler pulley or mower deck blade is loose. 3. The transaxle cooling fan is loose. 4. There is a problem with the electric clutch. 	<ol style="list-style-type: none"> 1. Tighten the engine mounting bolts. 2. Tighten the appropriate pulley or blade fastener. 3. Contact your Authorized Service Dealer. 4. Contact your Authorized Service Dealer.



Consumer Riding Products

THE TORO TOTAL COVERAGE GUARANTEE

A Full Two-Year Warranty
(Limited Warranty For Commercial Use)

What Is Covered By This Express Warranty?

The Toro Company promises to repair any TORO Product used for normal residential purposes* if defective in materials or workmanship for a period of two years from the date of purchase with the following exceptions:

- Batteries are warranted for one year

This warranty covers the cost of parts and labor as well as transportation within a 15 mile radius of the servicing dealer.

What Products Are Covered By This Warranty?

This warranty applies to all consumer riding products and their attachments.

How About Commercial Use?

TORO Consumer Products and attachments used for commercial, institutional or rental use are covered by a limited warranty for the following time periods from the date of purchase:

Products	Warranty Period
• 300 and 5xi Series Tractors	
Chassis	1 year limited warranty
Liquid Cooled Gas Engines .	1 year limited warranty
Air Cooled Gas and Diesel Engines	2 year limited warranty
• All Others	90 day limited warranty

How Do You Get Warranty Service?

Should you feel your TORO Product contains a defect in material or workmanship, contact the dealer who sold you the product or any Authorized TORO Service Dealer or TORO Master Service Dealer. The Yellow Pages of your telephone directory is a good reference source. The dealer will either arrange service at his/her dealership or recommend another Authorized Service Dealer who may be more convenient. You may need proof of purchase (copy of registration card, sales receipt, etc.) for warranty validation.

If for any reason you are dissatisfied with the Service Dealer's analysis of the defect in materials or workmanship or if you need a referral to a TORO Service Dealer, please feel free to contact us at the following address:

Toro Customer Service Department
8111 Lyndale Avenue South
Bloomington, MN 55420-1196
612-888-8801
800-348-2424

What Must You Do To Keep The Warranty In Effect?

You must maintain your TORO Product by following the maintenance procedures described in the operator's manual. Such routine maintenance, whether performed by a dealer or by you, is at your expense.

What Does This Warranty Not Cover? and

How Does Your State Law Relate To This Warranty?

There is no other express warranty except for special emission system coverage on some products. This express warranty does not cover:

- Cost of regular maintenance service or parts, such as filters, fuel, lubricants, tune-up parts, blade sharpening, brake and clutch adjustments.
- Any product or part which has been altered or misused or required replacement or repair due to normal wear, accidents, or lack of proper maintenance.
- Repairs necessary due to improper fuel, contaminants in the fuel system, or failure to properly prepare the fuel system prior to any period of non-use over three months.
- Pickup and delivery charges for distances beyond a 15 mile radius from an Authorized TORO Service Dealer.

All repairs covered by this warranty must be performed by an Authorized TORO Service Dealer using Toro approved replacement parts.

Repair by an Authorized TORO Service Dealer is your sole remedy under this warranty.

The Toro Company is not liable for indirect, incidental or consequential damages in connection with the use of the TORO Products covered by this warranty, including any cost or expense of providing substitute equipment or service during reasonable periods of malfunction or non-use pending completion of repairs under this warranty. Some states do not allow exclusions of incidental or consequential damages, so the above exclusion may not apply to you.

This warranty gives you specific legal rights, and you may also have other rights which vary from state to state.

* Normal residential purposes means mowing the lawn on the same lot as your home. Use at more than one location is considered commercial use and the commercial use warranty would apply.

COUNTRIES OTHER THAN THE UNITED STATES OR CANADA

Customers who have purchased TORO Products exported from the United States or Canada should contact their TORO Distributor (Dealer) to obtain guarantee policies for your country, province, or state. If for any reason you are dissatisfied with your Distributor's service or have difficulty obtaining guarantee information, contact the TORO importer. If all other remedies fail, you may contact us at The Toro Company.