



Count on it.

Parts Catalog

Walk-Behind Rotary Broom

Model No. 23740—Serial No. 316000001 and Up



Ordering Replacement Parts

To order replacement parts, please supply the part number, the quantity, and the description of each part desired.

Understanding Reference Numbers

Each identified part in an illustration has a reference number. The reference number for a part also appears in the parts list, along with other information about the part.

This catalog uses two special reference number formats, one to indicate parts in a service assembly and another to indicate the quantity of a given part in an illustration.

Service Assembly Reference Numbers

Parts in service assemblies have reference numbers in the form a:b. The a represents the reference number of the entire service assembly and the b represents a sequential number unique to each part within the service assembly.

For example, a wheel assembly might be identified by reference number 6, the tire by 6:1, the valve by 6:2, and the wheel by 6:3. When you order the assembly identified by reference number 6, you receive all parts identified by reference numbers 6:1, 6:2, and 6:3. However, you may also order any part individually. Reference numbers of this type appear in illustration and in parts lists.

Reference Numbers Indicating Quantity

In an illustration, if a reference number indicates more than one part, the reference number has the form nX y. The n represents the quantity of the part, the X is the multiplication symbol, and the y represents the reference number.

For example, in an illustration, the reference number 2X 37 means that two of the parts identified by reference number 37 are indicated.

List of Abbreviations

AR: as required

ASM: assembly

BBC: blade brake control

BHTF: button head thread forming

CARR: carriage

CCW: counter clockwise

CW: clockwise

DEG: degrees

DPA: Dual Point Adjustment

ECM: electronic control module

EXT: external

FH: flat head

GA: gauge

HD: heavy-duty

HF: hex flange

HH: hex head

HHF: hex head flange

HHFTF: hex head flange thread forming

HJ: hex jam

HLH: hex lag head

HOC: height-of-cut

HP: high pressure

HSBH: hex socket button head

HSFH: hex socket flat head

HSH: hex socket head

HWH: hex washer head

HWHTF: hex washer head thread forming

HYD: hydraulic

LH: left hand

LP: low pressure

LPG: Liquefied Petroleum Gas

NI: nylon insert

NPTF: national pipe thread fine

PFH: phillips flat head

PPH: phillips pan head

PPHTF: phillips pan head thread forming

PRH: phillips round head

PTH: phillips truss head

PTO: power-take-off

RH: right hand

ROPS: roll-over protection system

RRB: rear roller brush

SFH: slotted fillister head

SHH: slotted hex head

SHWH: slotted hex washer head

SPH: slotted pan head

SQH: square head

SRH: slotted round head

STD: standard

TAP: self tapping

TTH: torx truss head

Contents

Frame Assembly.....	4
Drive Assembly.....	6
Wheel Clutch Sprocket Assembly.....	8
Control Panel Assembly.....	10
Handle Assembly.....	12
Engine Assembly.....	14
Broom Assembly.....	16
Broom Mounting Assembly.....	18
Broom Head and Frame Assembly.....	20
Broom Core Assembly.....	21
Attachments and Accessories.....	22

Frame Assembly

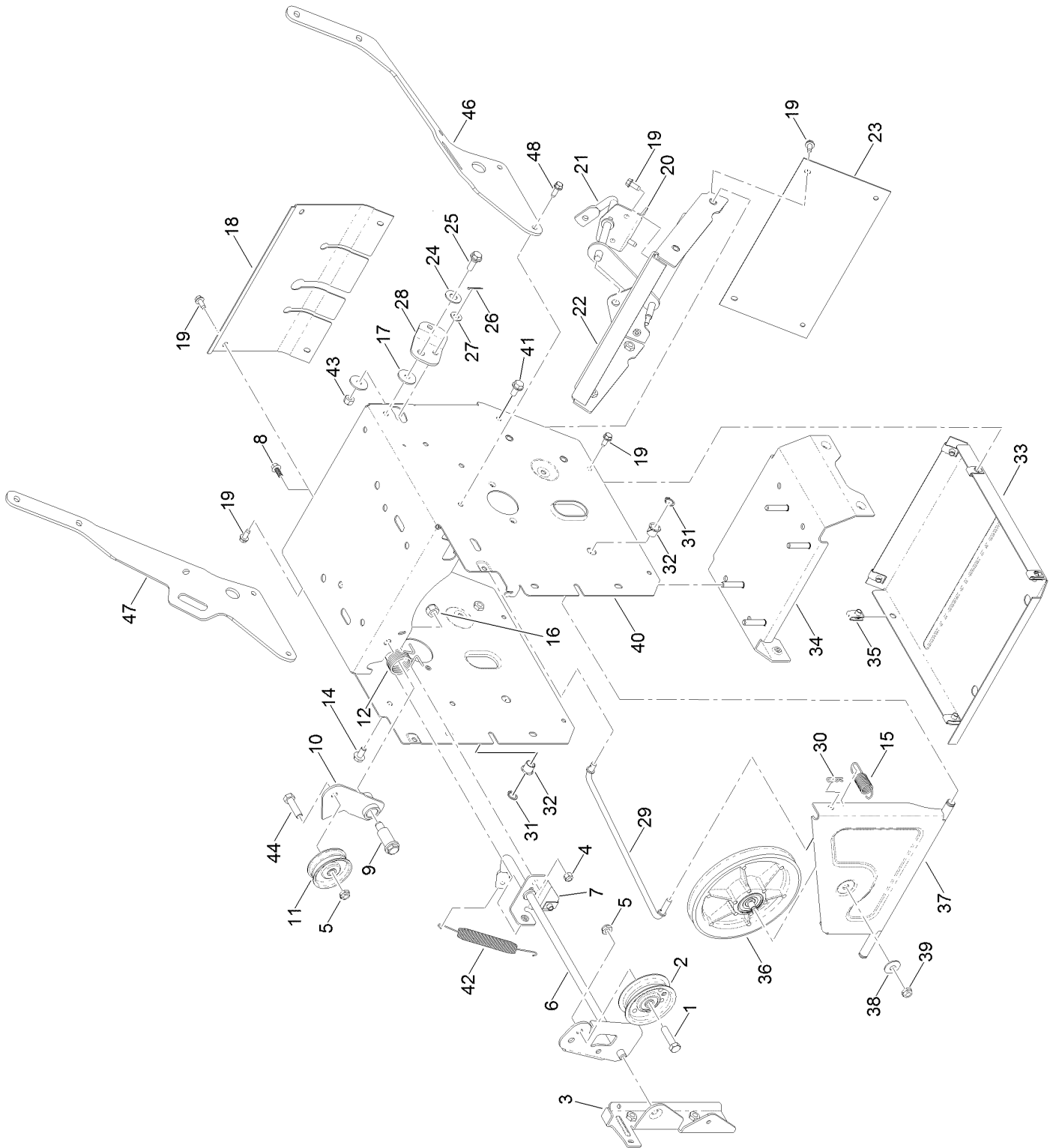

Frame Assembly (continued)

<i>Ref.</i>	<i>Part Number</i>	<i>Qty.</i>	<i>Description</i>	<i>Ref.</i>	<i>Part Number</i>	<i>Qty.</i>	<i>Description</i>
1	323-8	1	Screw-HH	25	27-0410	1	Screw-Shoulder
2	92-7104	1	Pulley-Idler	26	3272-4	1	Pin-Cotter
3	107-1039	1	Bracket-Idler, Impeller	27	3256-23	1	Washer-Flat
4	3296-42	1	Nut-Lock, NI	28	107-1011	1	Bellcrank-Drive
5	3296-59	2	Nut-Lock, NI	29	106-4467	1	Link-Control, Speed
6	107-3838-03	1	Impeller Clutch ASM	30	3290-307	1	Pin-Cotter
7	120-9824	1	Bracket-Clutch, Impeller	31	32151-61	2	Ring-Retaining
8	99-6810	1	Screw-HHF	32	256-257	2	Bushing-Nyliner
9	108-5056	1	Bolt-Shoulder ●	33	106-7330-01	1	Pan-Bottom
10	108-5058	1	Arm-Idler, Traction	34	116-7678	1	Brace-Frame
11	3-4244	1	Pulley-Idler	35	107069	8	Clip
12	108-7332	1	Spring-Torsion	36	108-0031	1	Pulley-Traction
14	3234-7	2	Screw-HHF	37	108-7307	1	Bracket-Wheel, Friction
15	107-1003	1	Spring-Extension	38	3290-340	1	Washer-Belleville
16	3296-76	1	Nut-Lock, NI	39	3296-5	1	Nut-Lock
17	5-4460	2	Washer-Pivot	40	120-9832-01	1	Traction Frame ASM
18	108-0022-01	1	Cover-Upper	41	32144-14	4	Screw-HWHTF
19	32144-10	13	Screw-HWH	42	108-2976	1	Spring-Extension
20	108-0036	1	Bracket-Rod, Shift	43	3296-29	1	Nut-Lock, NI
21	106-7268	1	Lever-Control, Traction	44	323-29	1	Screw-HH
22	108-0026-03	1	Shift Plate ASM	46	116-7672-03	1	Brace-Handle, LH
23	106-7345-01	1	Cover-Lower	47	116-7673-03	1	Brace-Handle, RH
24	25-5640	1	Washer	48	32144-44	4	Screw-HWH, Thread Roll

● Apply light coat of anti-seize to pivot surface.

Drive Assembly

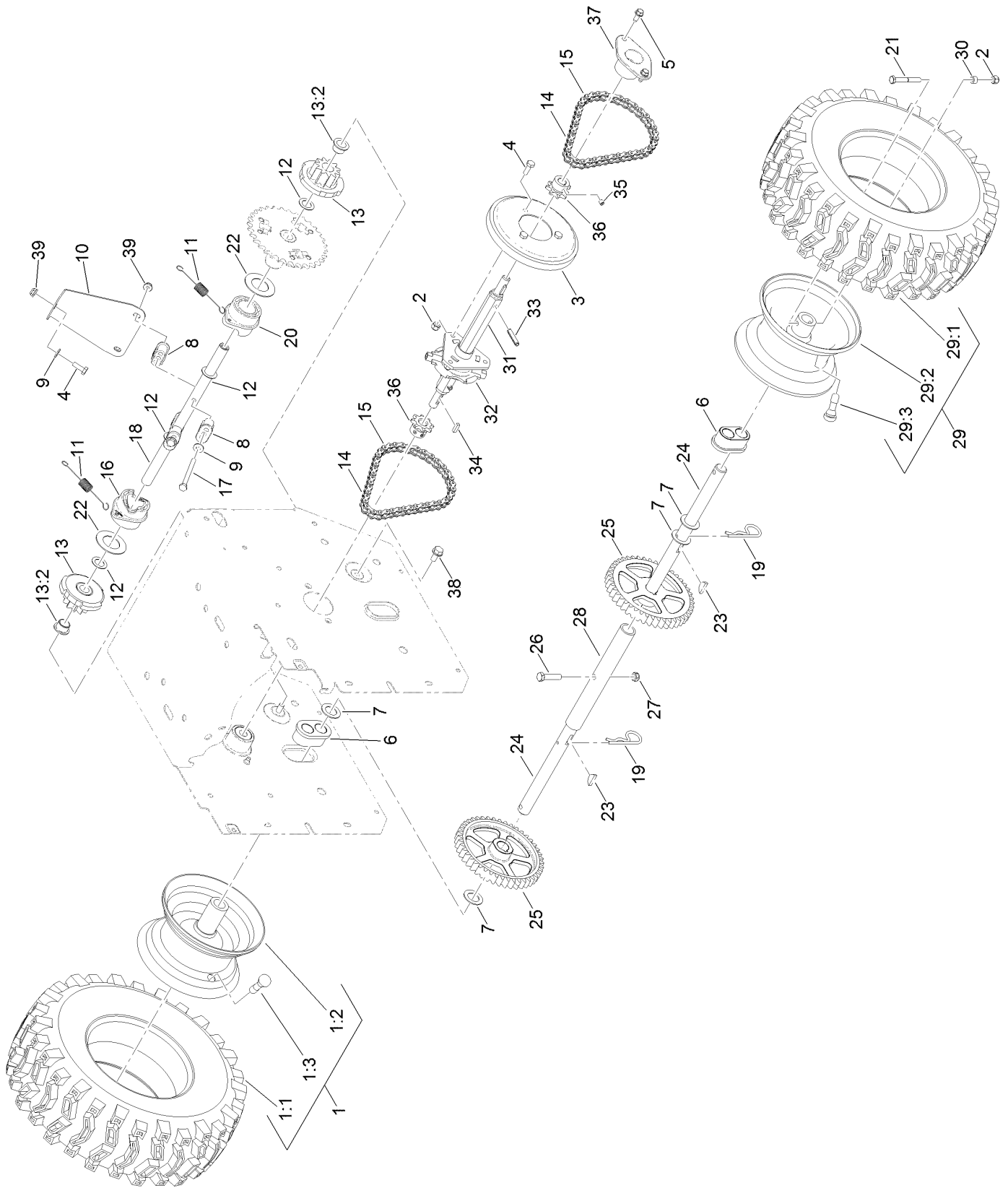

Drive Assembly (continued)

<i>Ref.</i>	<i>Part Number</i>	<i>Qty.</i>	<i>Description</i>	<i>Ref.</i>	<i>Part Number</i>	<i>Qty.</i>	<i>Description</i>
1	126-4257	1	RH Wheel And Tire ASM	20	107-8887	1	Collar-Shift, LH
1:1	107-3042	1	Tire	21	108-2975	2	Screw-HH
1:2	126-4256	1	Rim W/Valve Stem, Gray	22	107-8891	2	Washer-Thrust
1:3	232-27	1	Stem-Valve	23	3257-7	2	Key-Woodruff
2	3296-42	5	Nut-Lock, NI	24	107-8898	2	Shaft-Axle
3	119-1567	1	Wheel-Friction	25	106-4572	2	Gear-Axle, 44 Tooth
4	321-4	4	Screw-HH	26	322-17	1	Screw-HH
5	32144-10	4	Screw-HWH	27	3296-47	1	Nut-Lock, NI
6	106-4558	2	Bearing-Axle	28	106-7259	1	Tube-Axle
7	3-8664	4	Washer-Thrust	29	126-4258	1	LH Wheel And Tire ASM
8	107-8889	4	Guide-Collar	29:1	107-3042	1	Tire
9	3256-22	3	Washer-Flat	29:2	126-4256	1	Rim W/Valve Stem, Gray
10	107-8892-03	1	Brace-Collar, Shift	29:3	232-27	1	Stem-Valve
11	107-8893	2	Spring-Extension	30	55-9370	2	Spacer-Blade, Rotor
12	108-0015	4	Washer-Flat	31	116-7908	1	Shaft-Hex ■
13	107-8894	2	11T Gear ASM	32	106-4434	1	Trunnion-Hex
13:2	108-2973	2	Bushing-Flange	33	32121-9	2	Pin-Roll, Slotted
14	108-0016	2	Chain-Roller	34	94-8850	2	Key-Square
15	2710-6	2	Link-Connecting	35	3245-32	4	Screw-HSH
16	107-8888	1	Collar-Shift, RH	36	106-7317	2	Sprocket-8 Tooth
17	321-23	2	Screw-HH	37	108-7319	2	Retainer-Bearing
18	107-8883	1	Shaft-Intermediate ●	38	32144-14	2	Screw-HWHTF
19	3290-343	2	Pin-Hair	39	104-7201	3	Nut-Flange, NI

● Apply light coat of oil before assembly.

■ Apply light coat of oil to hex portion of shaft.

Wheel Clutch Sprocket Assembly

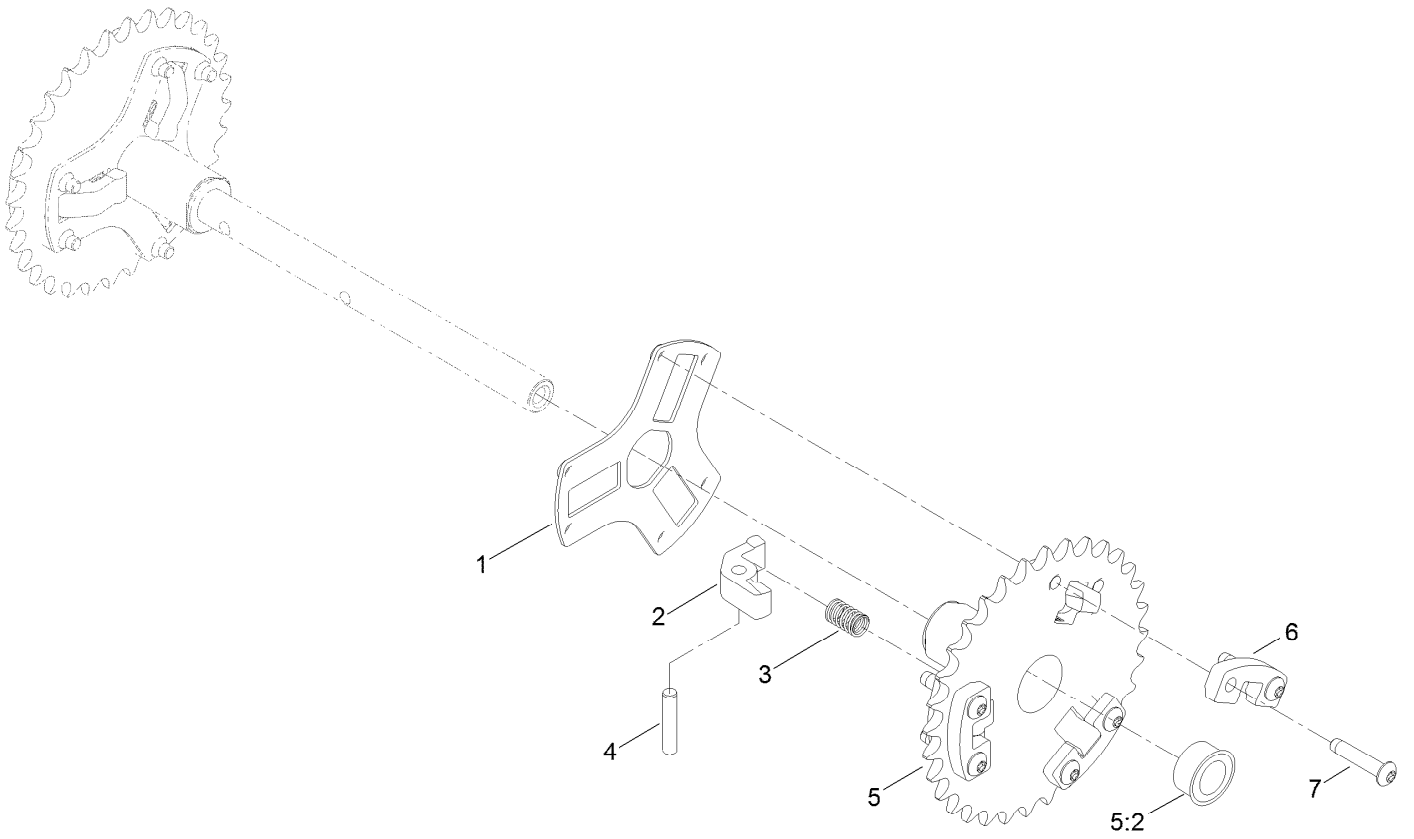

Wheel Clutch Sprocket Assembly (continued)

<i>Ref.</i>	<i>Part Number</i>	<i>Qty.</i>	<i>Description</i>	<i>Ref.</i>	<i>Part Number</i>	<i>Qty.</i>	<i>Description</i>
1	107-8886	2	Retainer-Pin, Pawl	5	107-8895	2	32T Sprocket ASM
2	107-8879	6	Pawl-Clutch	5:2	108-2973	2	Bushing-Flange
3	107-8885	6	Spring-Compression	6	107-8880	6	Support-Pawl
4	107-8899	6	Pin-Dowel ●	7	108-0035	12	Screw-Torx Button Head

● Apply light coat of oil before assembly.

Control Panel Assembly

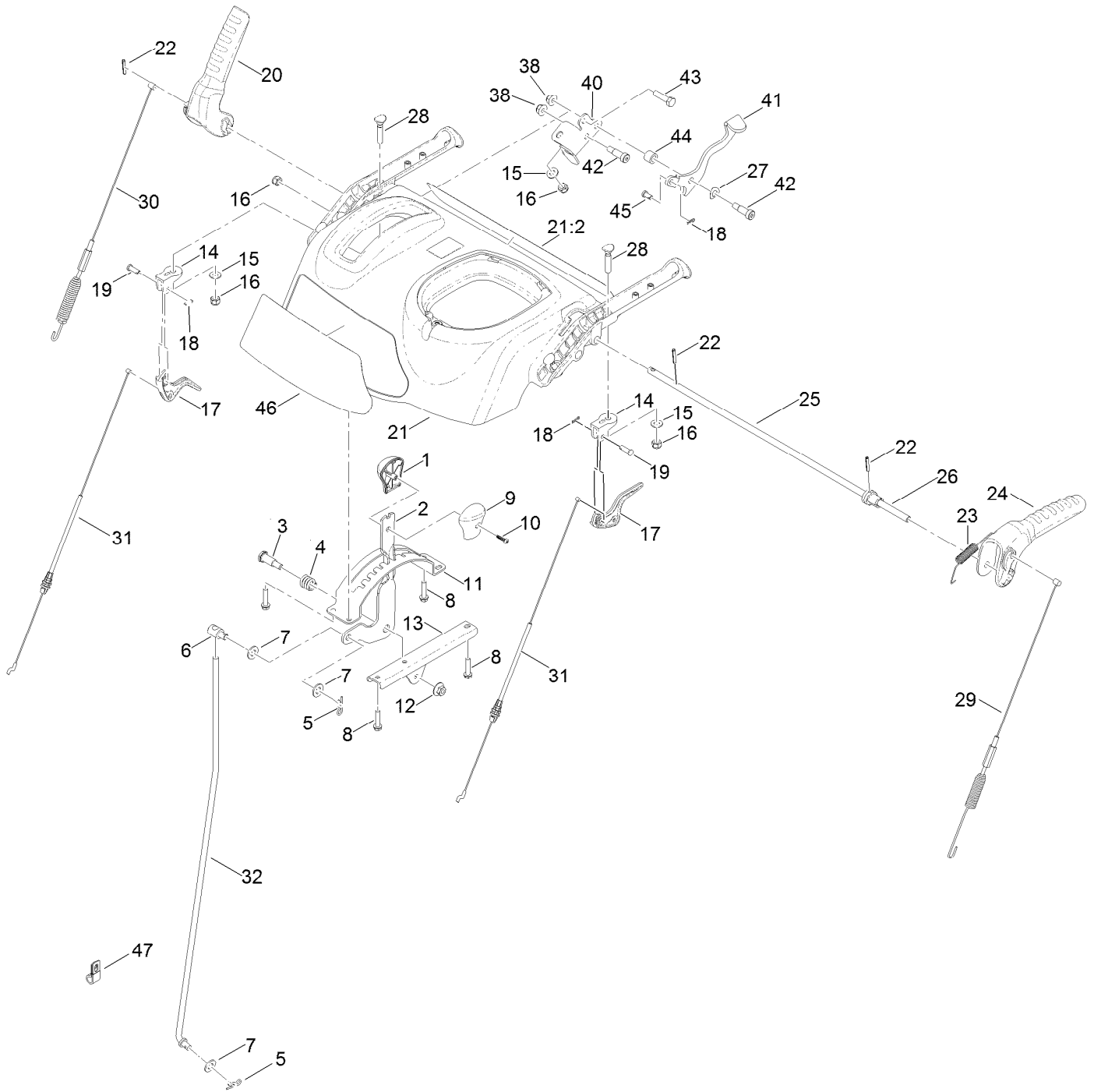

Control Panel Assembly (continued)

<i>Ref.</i>	<i>Part Number</i>	<i>Qty.</i>	<i>Description</i>	<i>Ref.</i>	<i>Part Number</i>	<i>Qty.</i>	<i>Description</i>
1	106-4423	1	Knob-Shift, RH	21:2	126-0017	1	Decal-Control, Panel
2	106-7278-03	1	Selector-Speed	22	32121-125	3	Pin-Spring
3	63-2650	1	Screw-Shoulder	23	107-3001	1	Spring-Tension
4	108-7313	1	Spring-Compression	24	106-4410	1	Lever-Traction
5	3290-307	2	Pin-Cotter	25	105-9996	1	Rod-Lockout
6	110-3446	1	Trunnion-Rod	26	107-1043	1	Cam-Lockout
7	3256-24	3	Washer-Flat	27	3290-212	1	Washer-Spring
8	46-8092	4	Screw-Plastite	28	107-3018	4	Screw-Handle
9	105-9999	1	Knob-Shift, LH	29	120-0132	1	Cable-Traction
10	94-4496	1	Screw-PPH	30	115-5685	1	Cable-Auger
11	106-7277-03	1	Guide-Selector, Speed	31	107-8896	2	Cable-Clutch
12	32128-13	1	Nut-HHF	32	107-1005	1	Rod-Shift
13	130-9775-03	1	Bracket-Selector, Speed	38	104-8300	2	Nut-Flange, NI
14	105-9980	2	Mount-Clutch, Lever	40	116-7669	1	Bracket-Lever, Broom Angle
15	3256-70	4	Washer-Flat	41	116-7670	1	Lever-Thumb, Broom Angle
16	3296-72	5	Nut-Lock, NI	42	119-6915	2	Screw-Shoulder, HSH
17	106-4505	2	Lever-Clutch	43	322-6	1	Screw-HH
18	108-2992	3	Pin-Hair	44	116-7793	1	Tube-Spacer
19	1-808265	2	Pin-Clevis	45	146319	1	Pin-Clevis
20	106-4413	1	Lever-Auger	46	126-0016	1	Decal-Toro, Power Broom
21	126-0063	1	Control Panel ASM	47	1-323229	1	Clip-Loom

Handle Assembly

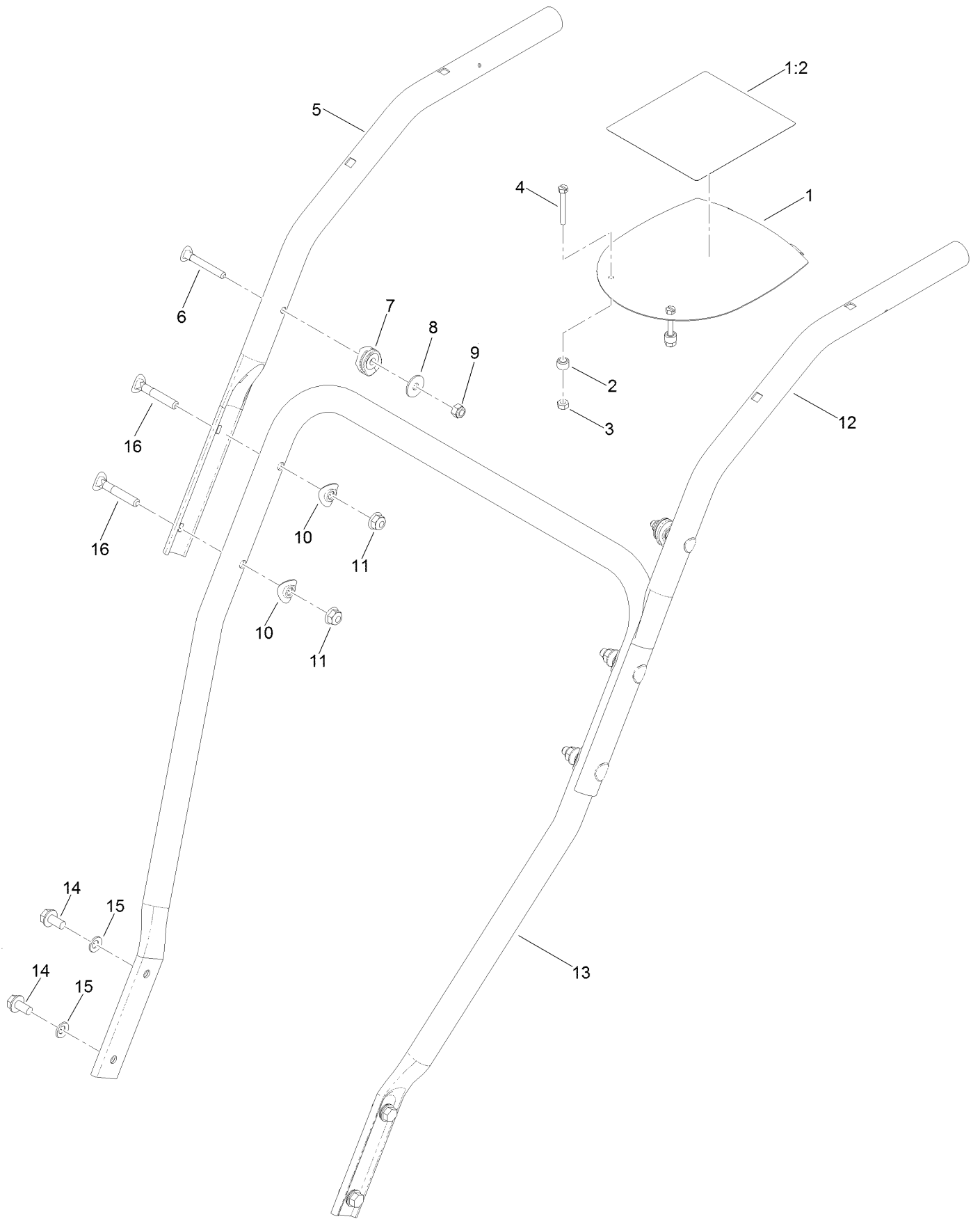

Handle Assembly (continued)

<i>Ref.</i>	<i>Part Number</i>	<i>Qty.</i>	<i>Description</i>	<i>Ref.</i>	<i>Part Number</i>	<i>Qty.</i>	<i>Description</i>
1	116-7788	1	Panel-Control	9	3296-73	2	Nut-Lock, NI
1:2	116-7370	1	Decal-Warning	10	107-3844	4	Washer
2	55-9370	2	Spacer-Blade, Rotor	11	104-8300	4	Nut-Flange, NI
3	3296-2	2	Nut-Lock, NI	12	127-5952-03	1	Handle-Upper, LH
4	32105-5	2	Screw	13	105-9981-03	1	Handle-Lower
5	127-5953-03	1	Handle-Upper, RH	14	32144-14	4	Screw-HWHTF
6	95-4453	2	Screw	15	3290-475	4	Washer-Belleville
7	106-4509	2	Clamp-Cable	16	92-2260	4	Screw-Handle
8	87-6630	2	Washer-Plain				

Engine Assembly

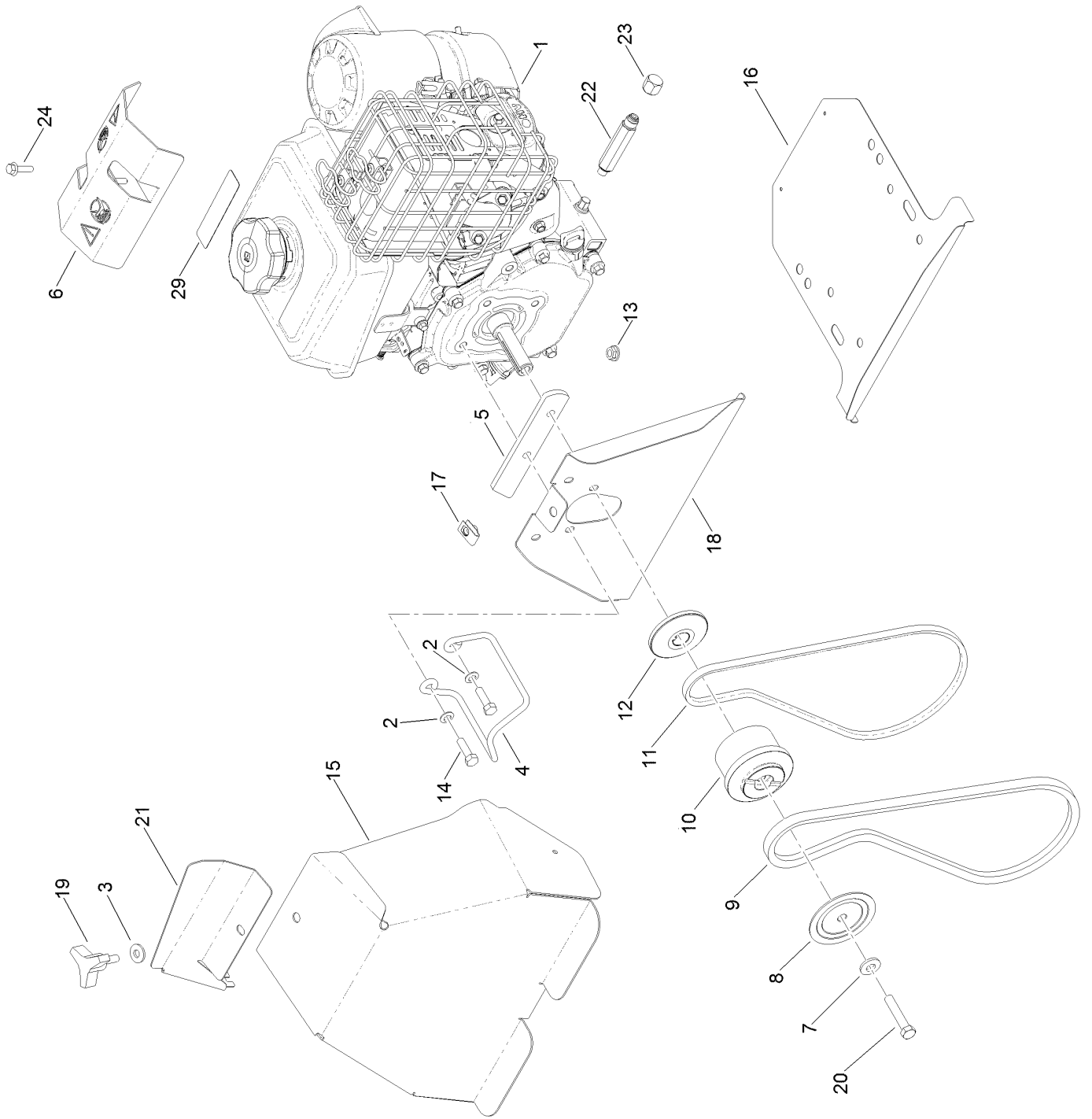

Engine Assembly (continued)

<i>Ref.</i>	<i>Part Number</i>	<i>Qty.</i>	<i>Description</i>	<i>Ref.</i>	<i>Part Number</i>	<i>Qty.</i>	<i>Description</i>
1		1	Engine-Kohler, Ch270 ●▲	14	3210-6	2	Screw-HH
2	3290-475	2	Washer-Belleville	15	116-7258-01	1	Cover-Belt
3	1-303334	1	Washer-Spring	16	116-8761-01	1	Shield-Drive
4	107-3835	1	Guide-Belt	17	94-2413	1	Nut-U
5	116-7659-03	1	Spacer-Cover, Belt	18	116-7431-01	1	Cover-Belt, Back
6	126-4178-03	1	Deflector-Debris, Muffler	19	106-2240	1	Knob
7	98-5975	1	Washer-Belleville	20	3211-9	1	Screw-HH ◆
8	112-8139	1	Sheave-Half, Impeller ■	21	116-7922-01	1	Shield-Ice
9	1-653332	1	Belt-Blower	22	116-8721	1	Adapter
10	112-8117	1	Pulley-Engine, Center ■	23	01-201-4520	1	Cap
11	94-8812	1	V Belt-Traction	24	33103-025	2	Screw-HHF
12	112-8138	1	Sheave-Half, Traction ■	29	117-2718	1	Decal-Arrester, Spark
13	32128-20	4	Nut-HF				

● Not serviced separately

▲ Obtain parts from www.kohlerplus.com

◆ Use Pro-Lock, Nut Type (P/N 1-840022, .5ml tube) on threads.

■ Apply anti-seize compound in bore.

Broom Assembly

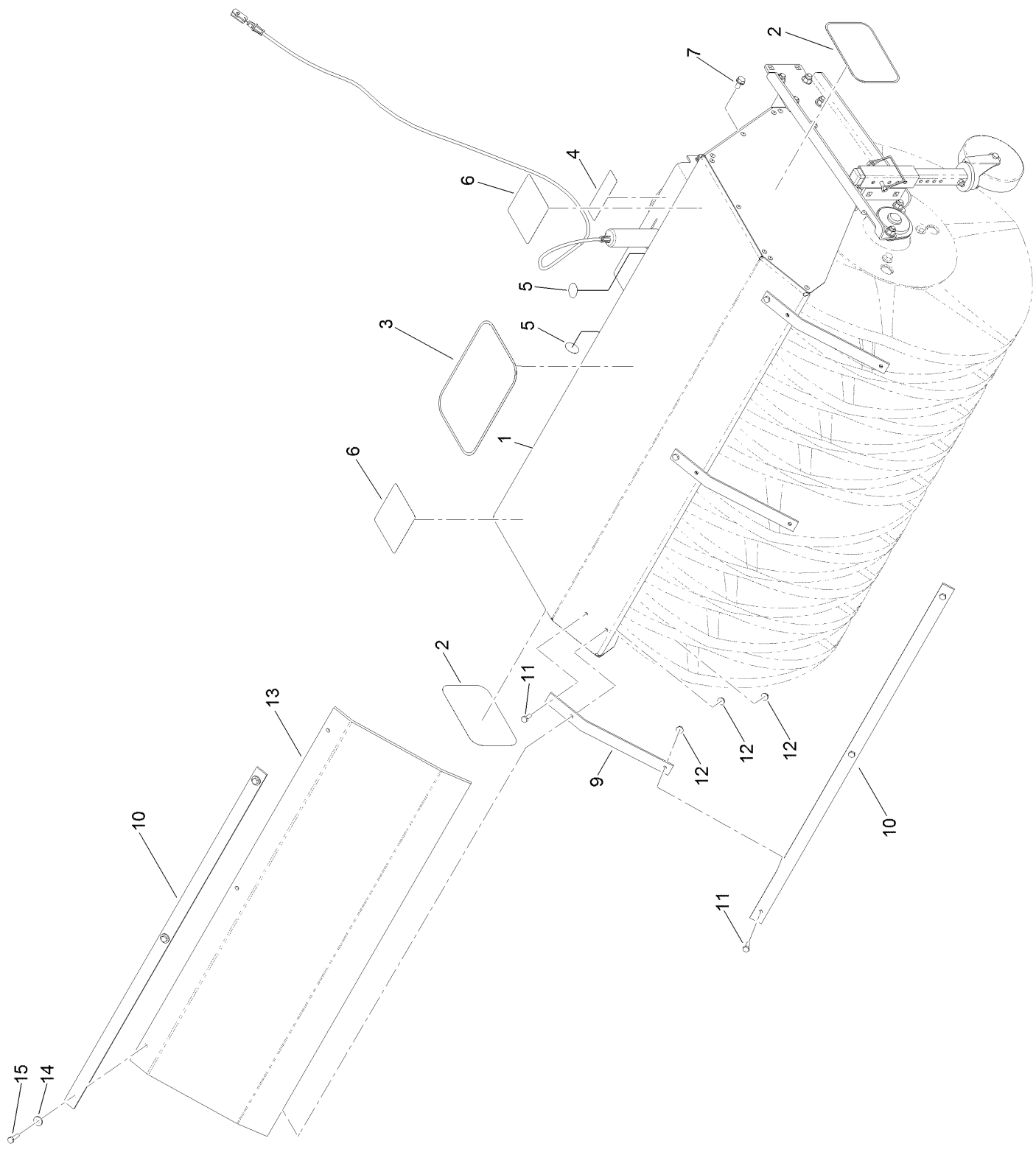

Broom Assembly (continued)

<i>Ref.</i>	<i>Part Number</i>	<i>Qty.</i>	<i>Description</i>	<i>Ref.</i>	<i>Part Number</i>	<i>Qty.</i>	<i>Description</i>
1		1	Broom ASM ●	10	116-8880-03	2	Strap-Support, Broom Deflector
2	62-5550	2	Decal	11	321-4	6	Screw-HH
3	66-6140	1	Decal	12	104-7201	9	Nut-Flange, NI
4	112-9028	1	Decal-Missing, Cover	13	116-8864	1	Deflector-Broom
5	115-2903	2	Decal-Grease	14	3256-2	3	Washer-Flat
6	116-8140	2	Decal-Warning	15	321-6	3	Screw-HH
7	32144-14	6	Screw-HWHTF				
9	116-8869-03	3	Strap-Support, Deflector				

● Not serviced separately

Broom Mounting Assembly

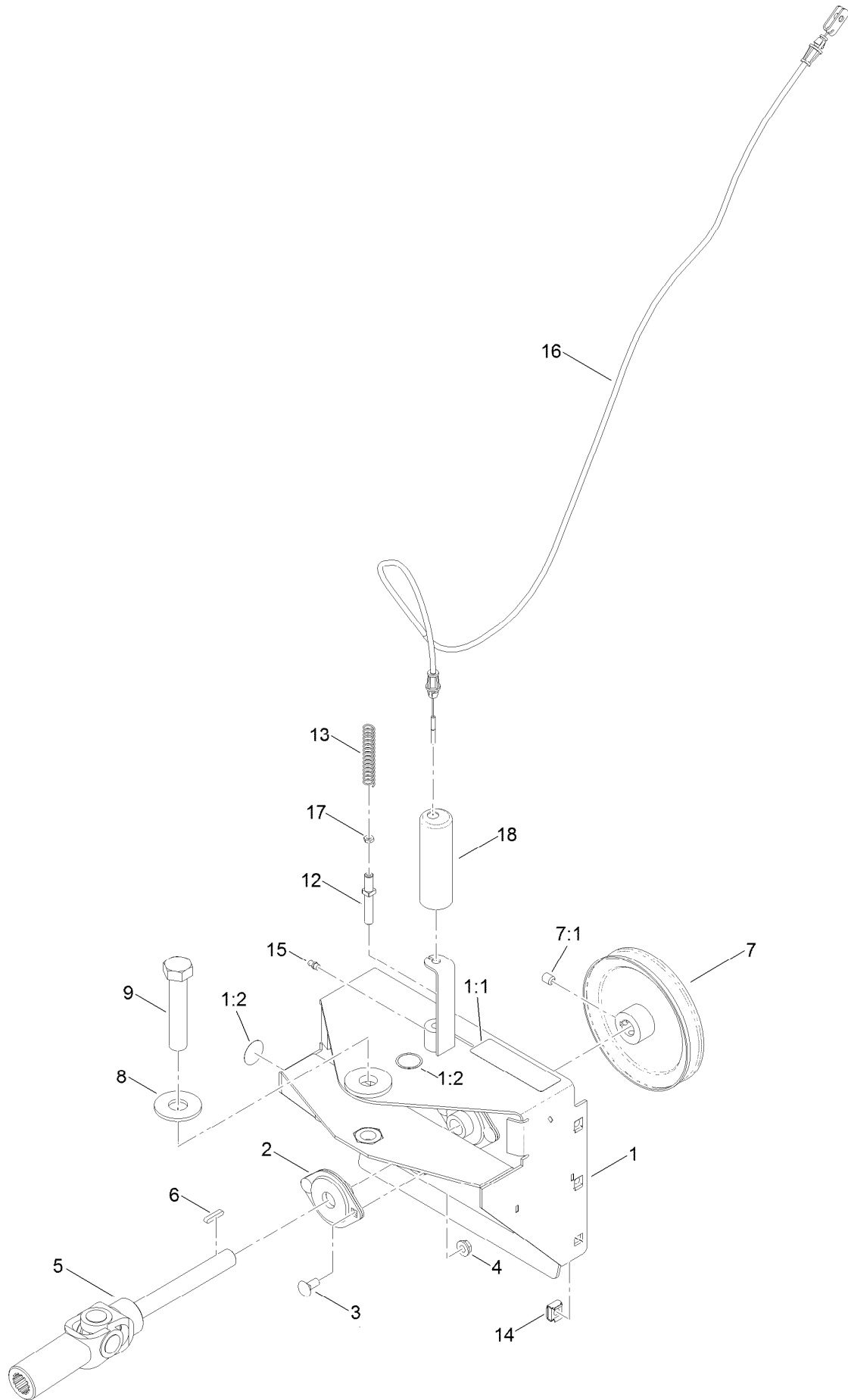

Broom Mounting Assembly (continued)

<i>Ref.</i>	<i>Part Number</i>	<i>Qty.</i>	<i>Description</i>	<i>Ref.</i>	<i>Part Number</i>	<i>Qty.</i>	<i>Description</i>
1	116-8122	1	Broom Mounting Frame ASM	7:1	3246-18	2	Setscrew
1:1	112-9028	1	Decal-Missing, Cover	8	3256-8	1	Washer-Flat
1:2	115-2903	2	Decal-Grease	9	3216-7	1	Screw-HH
2	116-8103	2	Bearing-Shaft	12	116-8106	1	Pin-Swing
3	3230-1	4	Bolt-CARR	13	116-8107	1	Spring-Compression
4	32128-20	4	Nut-HF	14	3290-496	6	Nut-Retainer
5	116-8104	1	Shaft-Drive	15	302-19	1	Fitting-Grease
6	116-8105	1	Key-Round End	16	116-7671	1	Cable-Angle, Broom
7	116-7930	1	Pulley-Impeller	17	3217-26	1	Nut-Hex
				18	116-8108	1	Cap

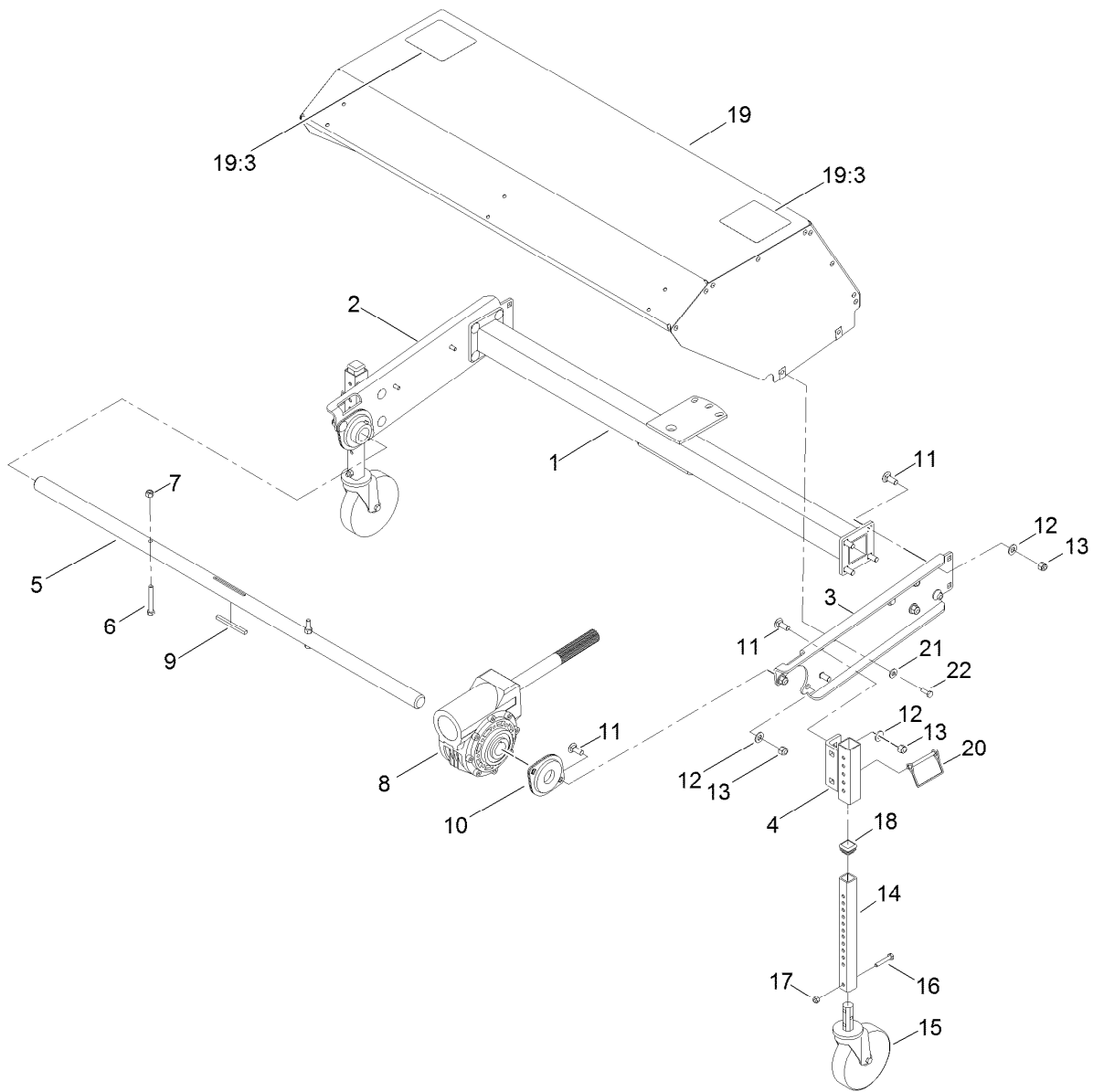

Broom Head and Frame Assembly

Ref.	Part Number	Qty.	Description	Ref.	Part Number	Qty.	Description
1	116-8544	1	Frame	13	3296-39	16	Nut-Lock, NI
2	116-8546	1	Arm-Right	14	116-8223	2	Tube-Square, Height Adjust
3	116-8545	1	Arm-Left	15	116-8117	2	Caster-Wheel
4	116-8543	2	Caster-Bracket	16	321-9	2	Screw-HH
5	116-8114	1	Shaft	17	3296-42	2	Nut-Lock, NI
6	322-11	2	Screw-HH	18	103-3202	2	Cap
7	3296-29	2	Nut-Lock, NI	19	116-8123	1	Broom Hood ASM
8	116-8115	1	Gearbox-Worm	19:3	116-8140	2	Decal-Warning
9	83-2800	1	Key-Straight	20	116-8224	2	Pin-Wire, Lock
10	116-8116	2	Bearing-Flange	21	3256-2	4	Washer-Flat
11	3231-2	16	Bolt-CARR	22	321-4	4	Screw-HH
12	3256-24	16	Washer-Flat				

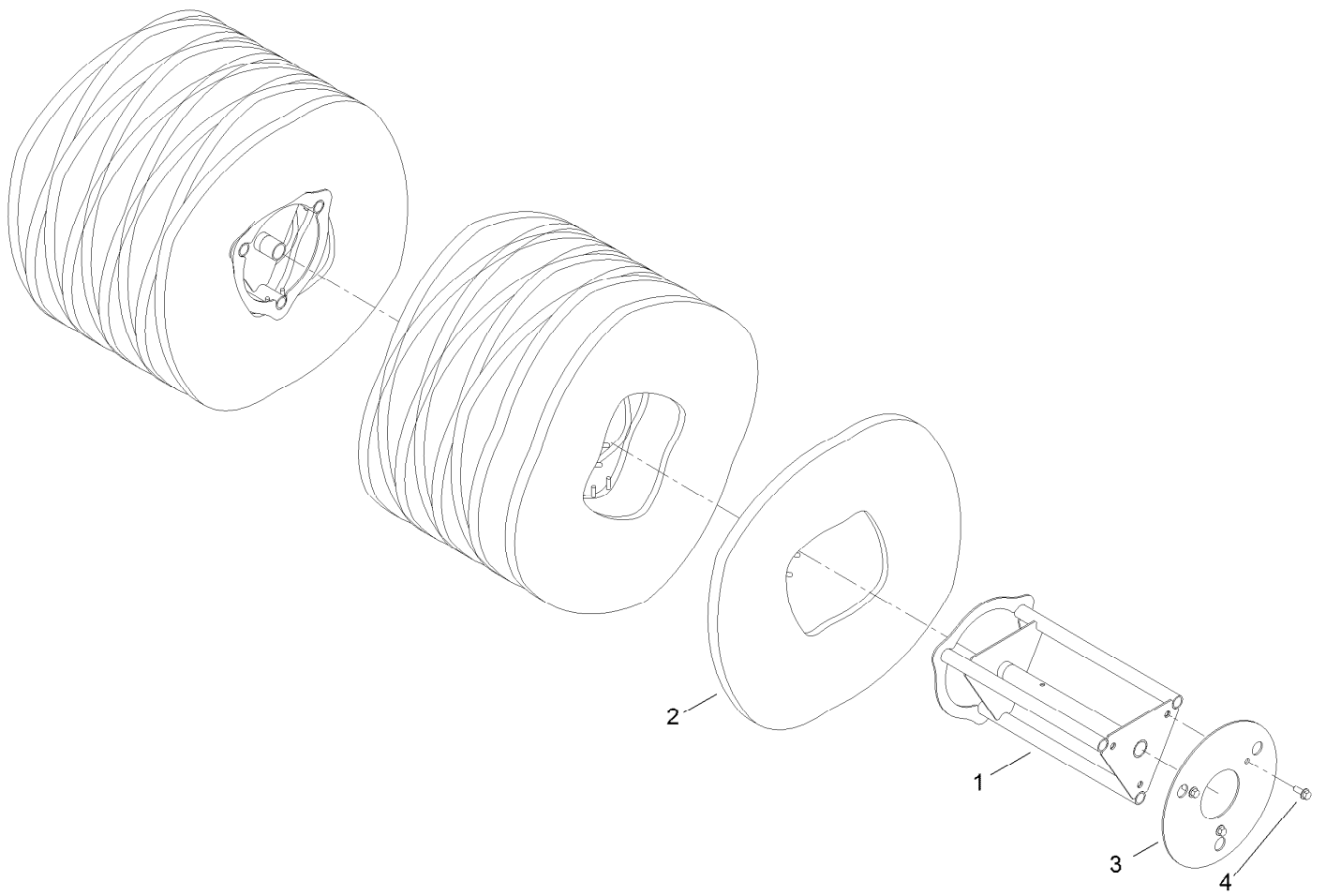

Broom Core Assembly

<i>Ref.</i>	<i>Part Number</i>	<i>Qty.</i>	<i>Description</i>
1	116-8119	2	Core-Broom
2	116-8120	18	Segment-Poly
3	116-8121	2	Plate-End, Retainer
4	3234-11	6	Screw-HHF

Attachments and Accessories

For 23740 Walk-Behind Rotary Broom

Product Name	Model/Part
Cab Kit.....	116-8227
Turf Caster Kit.....	116-8228
Dirt Deflector Kit.....	116-8229
Debris Box Kit.....	116-8230
Black Snow/Ice Wafers.....	116-8232
Yellow Turf Wafers.....	116-8233
Light Kit.....	116-8234
Rack Kit.....	116-9820
Electrical Power Kit.....	126-0023
Sprayer Boom Kit.....	126-0024

Notes:



Count on it.