



**Count on it.**

**Operator's Manual**

# Groundsmaster® 3400 4-Wheel Drive Traction Unit

Model No. 30651—Serial No. 314000001 and Up

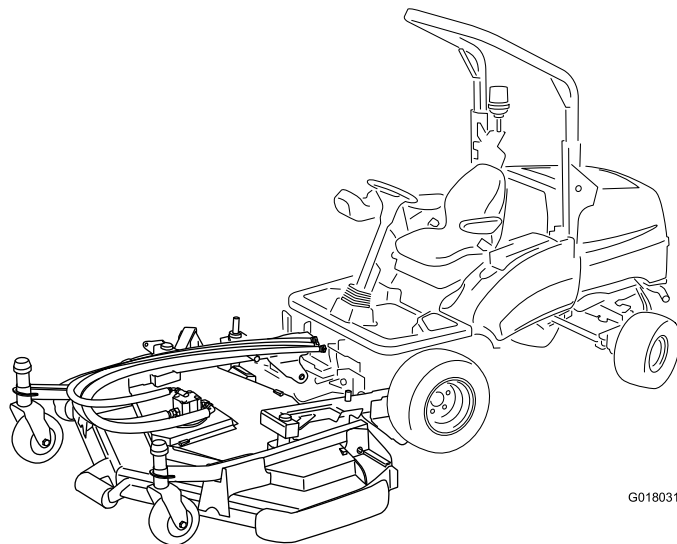

G018031



This product complies with all relevant European directives; for details, please see the separate product specific Declaration of Conformity (DOC) sheet.

# Introduction

This machine is a ride-on, rotary-blade lawn mower intended to be used by professional, hired operators in commercial applications. It is primarily designed for cutting grass on parks, sports fields, caravan parks, cemeteries and commercial grounds. It is not designed for cutting brush or for agricultural use.

Read this information carefully to learn how to operate and maintain your product properly and to avoid injury and product damage. You are responsible for operating the product properly and safely.

You may contact Toro directly for product and accessory information, help finding a dealer, or to register your product.

Whenever you need service, genuine Toro parts, or additional information, contact an Authorized Service Dealer or Toro Customer Service and have the model and serial numbers of your product ready. The model and serial numbers are on a plate mounted on the left side of the frame. Write the numbers in the space provided.

<b>Model No.</b> _____
<b>Serial No.</b> _____

This manual identifies potential hazards and has safety messages identified by the safety alert symbol (Figure 1), which signals a hazard that may cause serious injury or death if you do not follow the recommended precautions.



**Figure 1**

1. Safety alert symbol

---

This manual uses 2 words to highlight information.

**Important** calls attention to special mechanical information and **Note** emphasizes general information worthy of special attention.

# Contents

Safety .....	4	Checking the Rear Wheel Alignment .....	39
Safe Operating Practices .....	4	Cooling System Maintenance .....	40
Toro Riding Mower Safety .....	5	Removing Debris from the Cooling System .....	40
Sound Power Level .....	6	Brake Maintenance .....	41
Sound Pressure Level .....	6	Towing the Mower .....	41
Vibration Level .....	6	Belt Maintenance .....	43
Safety and Instructional Decals .....	8	Tensioning the Alternator Belt .....	43
Setup .....	10	Controls System Maintenance .....	43
1 Checking the Tire Pressure .....	10	Checking the Forward and Reverse Pedal	
2 Reading the Manual .....	10	Action .....	43
Product Overview .....	11	Operating the Presence Seat Switch .....	43
Controls .....	11	Using the Cutting Unit Interlock Switch .....	43
Specifications .....	20	Using the Parking-Brake Interlock Switch .....	43
Attachments/Accessories .....	20	Inspecting the Transmission Control Cable and	
Operation .....	21	Operating Mechanism .....	44
Checking the Engine-Oil Level .....	21	Transmission Neutral Interlock Switch .....	44
Checking the Cooling System .....	22	Hydraulic System Maintenance .....	45
Adding Fuel .....	22	Service the Hydraulic System .....	45
Checking the Hydraulic Fluid .....	23	Checking the Hydraulic-Fluid Overheat Warning	
Checking the Wheel Nut Torque .....	24	System .....	45
Using the Platform-Latching Mechanism .....	24	Checking the Hydraulic Lines and Hoses .....	46
Understanding the Operator-Presence		Miscellaneous Maintenance .....	46
Control .....	24	Waste Disposal .....	46
Starting and Stopping the Engine .....	25	Storage .....	47
Using Cutting-Unit Position Control .....	26	Preparing the Traction Unit .....	47
Engaging the Cutting Unit Drive .....	26	Preparing the Engine .....	47
Using the Weight Transfer/Traction		Troubleshooting .....	48
Assistance .....	26		
Folding the ROPS .....	27		
Jacking Points .....	28		
Raising The Mower off the Ground .....	28		
Transporting Machines .....	29		
Operating Tips .....	29		
Maintenance .....	30		
Recommended Maintenance Schedule(s) .....	30		
Daily Maintenance Checklist .....	31		
Pre-Maintenance .....	32		
Lubrication .....	33		
Greasing the Bearings, Bushings, and Pivots .....	33		
Engine Maintenance .....	34		
Checking the Engine-Overheat-Warning			
System .....	34		
Servicing the Air Cleaner .....	34		
Servicing the Engine Oil and Filter .....	35		
Fuel System Maintenance .....	36		
Replacing the Fuel Filter .....	36		
Bleeding the Fuel System .....	36		
Draining the Fuel Tank .....	37		
Checking the Fuel Lines and Connections .....	37		
Electrical System Maintenance .....	37		
Checking the Electrical System .....	37		
Checking the Battery Condition .....	37		
Servicing the Battery .....	38		
Drive System Maintenance .....	38		
Changing the Transmission-Oil Filter .....	38		
Changing the Hydraulic-Fluid-Return Filter .....	38		

# Safety

This machine has been designed in accordance with EN ISO 5395:2013.

Improper use or maintenance by the operator or owner can result in injury. To reduce the potential for injury, comply with these safety instructions and always pay attention to the safety alert symbol, which means Caution, Warning, or Danger. Failure to comply with the instruction may result in personal injury or death.

## Safe Operating Practices

### Training

- Read the *Operator's Manual* and other training material carefully. Be familiar with the controls, safety signs, and the proper use of the equipment.
- Never allow children or people unfamiliar with these instructions to use or service the mower. Local regulations may restrict the age of the operator.
- Never mow while people, especially children, or pets are nearby.
- Keep in mind that the operator or user is responsible for accidents or hazards occurring to other people or their property.
- Do not carry passengers.
- All drivers and mechanics should seek and obtain professional and practical instruction. The owner is responsible for training the users. Such instruction should emphasize:
  - the need for care and concentration when working with ride-on machines;
  - control of a ride-on machine sliding on a slope will not be regained by the application of the brake. The main reasons for loss of control are:
    - ◇ insufficient wheel grip;
    - ◇ being driven too fast;
    - ◇ inadequate braking;
    - ◇ the type of machine is unsuitable for its task;
    - ◇ lack of awareness of the effect of ground conditions, especially slopes;
- The owner/user can prevent and is responsible for accidents or injuries occurring to himself or herself, other people, or property.

### Preparation

- While mowing, always wear slip-resistant footwear, long trousers, safety glasses, and hearing protection. Tie back long hair. Do not wear loose clothing or jewelry.
- Thoroughly inspect the area where the equipment is to be used and remove all objects which may be thrown by the machine.

- **Warning**—Fuel is highly flammable. Take the following precautions:
  - Store fuel in containers specifically designed for this purpose.
  - Refuel outdoors only and do not smoke while refuelling.
  - Add fuel before starting the engine. Never remove the cap of the fuel tank or add fuel while the engine is running or when the engine is hot.
  - If fuel is spilled, do not attempt to start the engine but move the machine away from the area of spillage and avoid creating any source of ignition until fuel vapors have dissipated.
  - Replace all fuel tanks and container caps securely.
- Replace faulty silencers/mufflers.
- Only use accessories and attachments approved by the manufacturer.
- Before using, always visually inspect to see that the blades, blade bolts and cutter assembly are not worn or damaged. Replace worn or damaged blades and bolts in sets to preserve balance.
- Always make sure that the folding ROPS is secured in its vertical operating position before use.
- On multi-bladed machines, take care as rotating one blade can cause other blades to rotate.
- Check that the operator's presence controls, safety switches and shields are attached and functioning properly. Do not operate unless they are functioning properly.

### Operation

- Do not operate the engine in a confined space where dangerous carbon monoxide fumes can collect.
- Mow only in daylight or in good artificial light.
- Before attempting to start the engine, engage the parking brake, disengage the cutting unit drive system and ensure that the forward/reverse speed controls are in the neutral position.
- Do not use on a slope of more than 16 degrees. Care should be taken when using the mower on any slope where ground conditions are such that there may be a risk of the mower rolling over.
- Remember there is no such thing as a safe slope. Travel on grass slopes requires particular care. To guard against overturning:
  - do not stop or start suddenly when going up or downhill;
  - machine speeds should be kept low on slopes and during tight turns;
  - stay alert for humps and hollows and other hidden hazards;
  - Do not turn sharply. Use care when reversing.

- Stay alert for holes in the terrain and other hidden hazards.
- Watch out for traffic when crossing or near roadways.
- Stop the blades rotating before crossing surfaces other than grass.
- When using any attachments, never direct discharge of material toward bystanders nor allow anyone near the machine while in operation.
- Never operate the machine with damaged guards, shields, or without safety protective devices in place. Be sure that all interlocks are attached, adjusted properly, and functioning properly.
- Do not change the engine governor settings or over-speed the engine. Operating the engine at excessive speed may increase the hazard of personal injury.
- Before leaving the operator's position:
  - stop on level ground;
  - disengage the drive to the attachment,
  - lower the attachment to the ground;
  - Ensure the transmission is in neutral and engage the parking brake;
  - stop the engine and remove the key.
- When transporting the mower:
  - disengage the drive to the cutting unit,
  - raise the cutting unit to the transport position.
- Stop the engine and disengage drive to the cutting unit:
  - before refuelling;
  - before making height adjustment unless adjustment can be made from the operator's position.
  - before clearing blockages;
  - before checking, cleaning or working on the mower;
  - after striking a foreign object or if an abnormal vibration occurs. Inspect the mower for damage and make repairs before restarting and operating the equipment.
- Reduce the throttle setting during engine run-out and, if the engine is provided with a shut-off valve, turn the fuel off at the conclusion of mowing.
- Keep hands and feet away from the cutting units.
- Look behind and down before backing up to be sure of a clear path.
- Always wear the seat belt when the folding ROPS is in its vertical operating position.
- Never wear the seat belt when the folding ROPS is **not** in its vertical operating position.
- Slow down and use caution when making turns and crossing roads and sidewalks. Stop cutting unit if not mowing.
- Do not operate the mower while sick, tired, or under the influence of alcohol or drugs.
- Lightning can cause severe injury or death. If lightning is seen or thunder is heard in the area, do not operate the machine; seek shelter.
- Use care when loading or unloading the machine into a trailer or truck.
- Use care when approaching blind corners, shrubs, trees, or other objects that may obscure vision.

## Maintenance and Storage

- Keep all nuts, bolts, and screws tight to be sure the equipment is in safe working condition.
- Never store the equipment with fuel in the tank inside a building where fumes may reach an open flame or spark.
- Allow the engine to cool before storing in any enclosure.
- To reduce the fire hazard, keep the engine, silencer/muffler, battery compartment and fuel storage area free of grass, leaves, or excessive grease.
- Keep all parts in good working condition and all hardware and hydraulic fittings tightened. Replace all worn or damaged parts and decals.
- If you must drain the fuel tank, do it outdoors.
- Be careful during adjustment of the machine to prevent entrapment of the fingers between moving blades and fixed parts of the machine.
- Disengage drives, lower the cutting units, set parking brake, stop engine and remove key from ignition. Wait for all movement to stop before adjusting, cleaning or repairing.
- Use jack stands to support components when required.
- Carefully release pressure from components with stored energy.
- Disconnect battery before making any repairs. Disconnect the negative terminal first and the positive last. Connect positive first and negative last.
- Use care when checking the blades. Wear gloves and use caution when servicing them. Only replace blades; never straighten or weld them.
- Keep your hands and feet away from moving parts. If possible, do not make adjustments with the engine running.
- Charge batteries in an open well ventilated area, away from spark and flames. Unplug charger before connecting or disconnecting from battery. Wear protective clothing and use insulated tools.

## Toro Riding Mower Safety

The following list contains safety information specific to Toro products or other safety information that you must know that is not included in the safety standards.

This product is capable of amputating hands and feet and throwing objects. Always follow all safety instructions to avoid serious injury or death.

Use of this product for purposes other than its intended use could prove dangerous to user and bystanders.

## **⚠ WARNING**

**Engine exhaust contains carbon monoxide, which is an odorless, deadly poison that can kill you.**

**Do not run engine indoors or in an enclosed area.**

- Know how to stop the engine quickly.
- Wearing safety shoes is advisable and required by some local ordinances and insurance regulations.
- Handle fuel carefully. Wipe up any spills.
- Check the safety interlock switches daily for proper operation. If a switch should fail, replace the switch before operating the machine.
- Before starting the engine, sit on the seat.
- Using the machine demands attention. To prevent loss of control:
  - Do not drive close to sand traps, ditches, creeks, or other hazards.
  - Reduce speed when making sharp turns. Avoid sudden stops and starts.
  - When near or crossing roads, always yield the right-of-way.
  - Apply the service brakes when going downhill to keep forward speed slow and to maintain control of the machine.
- Raise the cutting units when driving from one work area to another.
- Do not touch the engine, silencer/muffler, or exhaust pipe while the engine is running or soon after it has stopped because these areas could be hot enough to cause burns.
- If the engine stalls or loses headway and cannot make it to the top of a slope, do not turn the machine around. Always back slowly, straight down the slope.
- When a person or pet appears unexpectedly in or near the mowing area, stop mowing. Careless operation, combined with terrain angles, ricochets, or improperly positioned guards can lead to thrown object injuries. Do not resume mowing until the area is cleared.

## **Maintenance and Storage**

- Make sure that all hydraulic line connectors are tight and that all hydraulic hoses and lines are in good condition before applying pressure to the system.
- Keep your body and hands away from pin hole leaks or nozzles that eject hydraulic fluid under high pressure. Use paper or cardboard, not your hands, to search for leaks. Hydraulic fluid escaping under pressure can have

sufficient force to penetrate the skin and cause serious injury. Seek immediate medical attention if fluid is injected into skin.

- Before disconnecting or performing any work on the hydraulic system, you must relieve all pressure in the system by stopping the engine and lowering the cutting units and attachments to the ground.
- Check all fuel lines for tightness and wear on a regular basis. Tighten or repair them as needed.
- If the engine must be running to perform a maintenance adjustment, keep your hands, feet, clothing, and any parts of the body away from the cutting units, attachments, and any moving parts. Keep everyone away.
- To ensure safety and accuracy, have an Authorized Toro Distributor check the maximum engine speed with a tachometer. Maximum governed engine speed should be 3,000 rpm.
- If you need to make major repairs or desire assistance, contact an Authorized Toro Distributor.
- Use only Toro-approved attachments and replacement parts. The warranty may be voided if used with unapproved attachments.

## **Sound Power Level**

### **Model 30651 with Model 30645**

This unit has a guaranteed sound power level of 104 dBA, which includes an Uncertainty Value (K) of 2 dBA. Sound power level was determined according to the procedures outlined in ISO 11094.

### **Model 30651 with Model 30646**

This unit has a guaranteed sound power level of 105 dBA, which includes an Uncertainty Value (K) of 2 dBA. Sound power level was determined according to the procedures outlined in ISO 11094.

## **Sound Pressure Level**

### **Model 30651 with Model 30645**

This unit has a sound pressure level at the operator's ear of 93 dBA, which includes an Uncertainty Value (K) of 2 dBA. Sound pressure level was determined according to the procedures outlined in EN ISO 5395.

### **Model 30651 with Model 30646**

This unit has a sound pressure level at the operator's ear of 94 dBA, which includes an Uncertainty Value (K) of 2 dBA. Sound pressure level was determined according to the procedures outlined in EN ISO 5395.

## **Vibration Level**

### **Model 30651 with Model 30645**

### **Hand-Arm**

Measured vibration level for right hand = 1.5 m/s<sup>2</sup>

Uncertainty Value (K) = 0.8 m/s<sup>2</sup>

Measured vibration level for left hand = 1.0 m/s<sup>2</sup>

Uncertainty Value (K) = 0.5 m/s<sup>2</sup>

Measured values were determined according to the procedures outlined in EN ISO 5395.

### **Whole Body**

Measured vibration level = 0.5 m/s<sup>2</sup>

Uncertainty Value (K) = 0.3 m/s<sup>2</sup>

Measured values were determined according to the procedures outlined in EN ISO 5395.

### **Model 30651 with Model 30646**

#### **Hand-Arm**

Measured vibration level for right hand = 1.5 m/s<sup>2</sup>

Uncertainty Value (K) = 0.8 m/s<sup>2</sup>

Measured vibration level for left hand = 1.0 m/s<sup>2</sup>

Uncertainty Value (K) = 0.5 m/s<sup>2</sup>

Measured values were determined according to the procedures outlined in EN ISO 5395.

### **Whole Body**

Measured vibration level = 0.5 m/s<sup>2</sup>

Uncertainty Value (K) = 0.3 m/s<sup>2</sup>

Measured values were determined according to the procedures outlined in EN ISO 5395.

# Safety and Instructional Decals



Safety decals and instructions are easily visible to the operator and are located near any area of potential danger. Replace any decal that is damaged or lost.

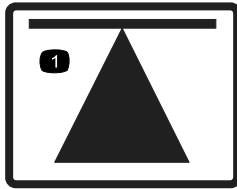

70-13-072

1. Jacking point



950889

1. Warning—hot surfaces.

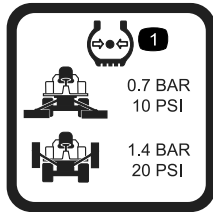

950832

1. Tire pressure

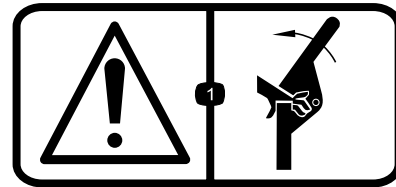

111-0773

1. Warning—crushing of fingers, force applied from side.

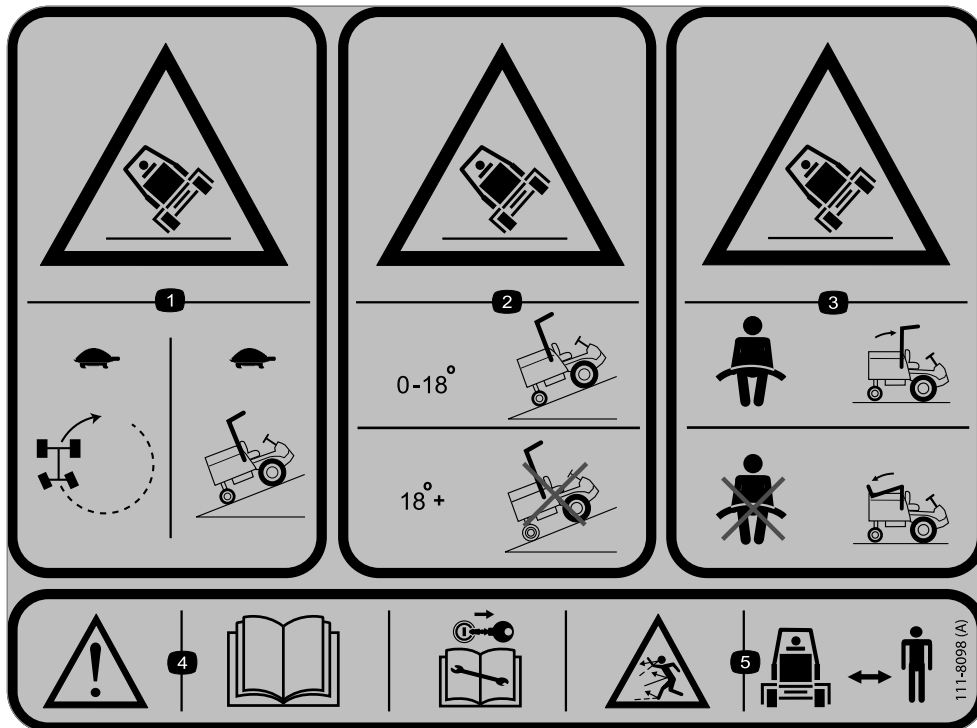

111-8098

1. Tipping hazard—drive slowly when turning or going up slopes.
2. Tipping hazard—only drive up slopes that are between 0 and 18 degrees; do not drive up slopes that are greater than 18 degrees.
3. Tipping hazard—wear a seatbelt when the ROPS is up; do not wear a seatbelt when the ROPS is down.
4. Warning—read the *Operator's Manual*; remove the key from the ignition and read the *Operator's Manual* before servicing or performing maintenance; thrown object hazard; keep bystanders away from the machine.

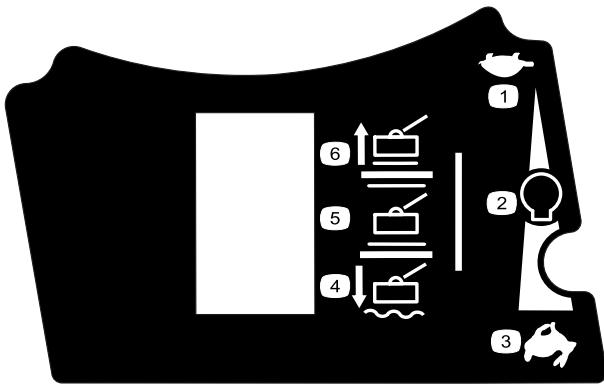

111-5233

- |                                     |   |
|-------------------------------------|---|
| 1. Slow                             | 4. Float the cutting unit over the ground |
| 2. Continuous variable engine speed | 5. Neutral cutting unit                   |
| 3. Fast                             | 6. Raise the cutting unit                 |

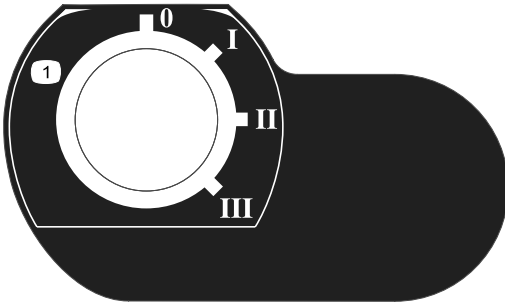

111-3344

1. Ignition switch



111-3562

1. Press pedal to adjust steering wheel tilt.

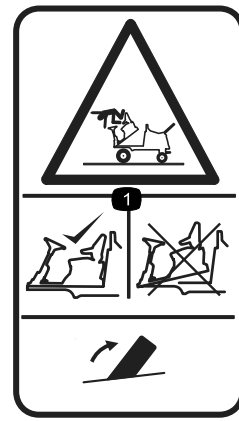

111-3566

1. Falling, crushing hazard—ensure platform latch is engaged before operating.

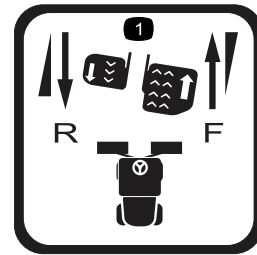

111-3567

1. Pedal operation

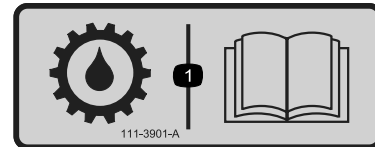

111-3901

1. Transmission oil—read the *Operator's Manual* for more information.



111-3902

1. Warning—cutting hazard of hand, fan.
2. Hot surfaces—read the *Operator's Manual* for more information.

# Setup

## Loose Parts

Use the chart below to verify that all parts have been shipped.

Procedure	Description	Qty.	Use
1	Tire pressure gauge (not supplied)	1	Check the tire pressure.
2	Operator's Manual Engine Operator's Manual Parts Catalog CE certificate	1 1 1 1	Read the Operator's Manual before operating the machine.

**Note:** Determine the left and right sides of the machine from the normal operating position.



## Checking the Tire Pressure

Parts needed for this procedure:

1	Tire pressure gauge (not supplied)
---	------------------------------------

## Procedure

Correct air pressure in the front and rear tires. See the chart below for the correct pressure.

**Important:** Maintain correct tire pressures in all tires to ensure correct contact with the turf.

Tires	Tire Type	Recommended Tire Pressures		
		Turf Conditions	Road Conditions	Max Pressure
Front Axle	26 x 12.00 - 12 BKT turf pattern	0.7 bar (10 psi)	1.4 bar (20 psi)	1.7 bar (25 psi)
Rear Axle	20 x 10.00 - 8 6 BKT turf pattern	0.7 bar (10 psi)	1.4 bar (20 psi)	1.7 bar (25 psi)



## Reading the Manual

Parts needed for this procedure:

1	<i>Operator's Manual</i>
1	<i>Engine Operator's Manual</i>
1	<i>Parts Catalog</i>
1	CE certificate

## Procedure

- Read the *Operator's Manual*.
- Store all documentation in a safe place for future use.

# Product Overview

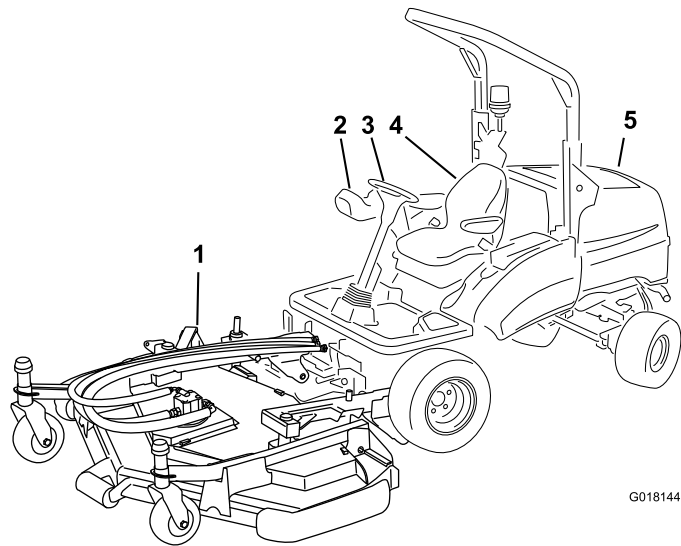

G018144

**Figure 2**

- |                   |                    |
|-------------------|--------------------|
| 1. Cutting unit   | 4. Operator's seat |
| 2. Control arm    | 5. Hood            |
| 3. Steering wheel |                    |

# Controls

## Control Panel Components

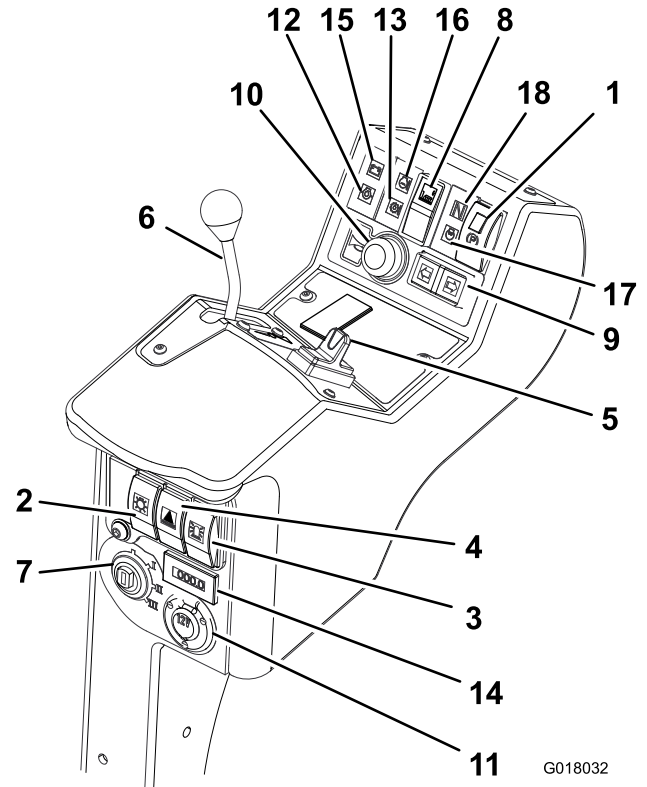

G018032

**Figure 3**

- |  |   |
|--|---|
| 1. Parking-brake switch                                    | 10. Horn button (supplied with light kit)           |
| 2. Light switch (supplied with light kit)                  | 11. Auxiliary 12 V socket (supplied with a 12V kit) |
| 3. Warning-beacon switch (supplied with beacon kit)        | 12. Oil-pressure indicator                          |
| 4. Hazard-warning switch (supplied with lighting kit)      | 13. Transmission-temperature indicator              |
| 5. Cutting-unit position control                           | 14. Hour meter                                      |
| 6. Throttle-control lever                                  | 15. Battery-warning indicator                       |
| 7. Ignition switch   | 16. Engine-temperature warning indicator            |
| 8. Cutting-unit drive switch                               | 17. Glow-plug indicator                             |
| 9. Direction-indicator switch (supplied with lighting kit) | 18. Transmission-neutral indicator                  |

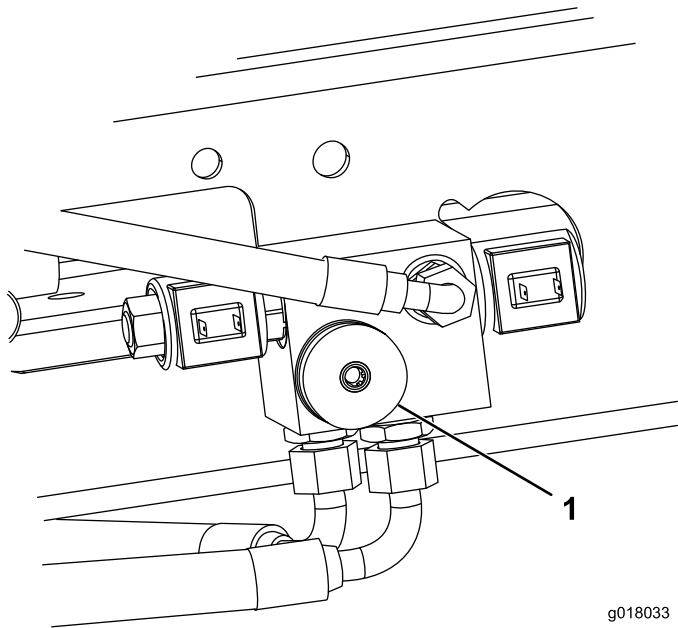

**Figure 4**

g018033

1. Weight-transfer control

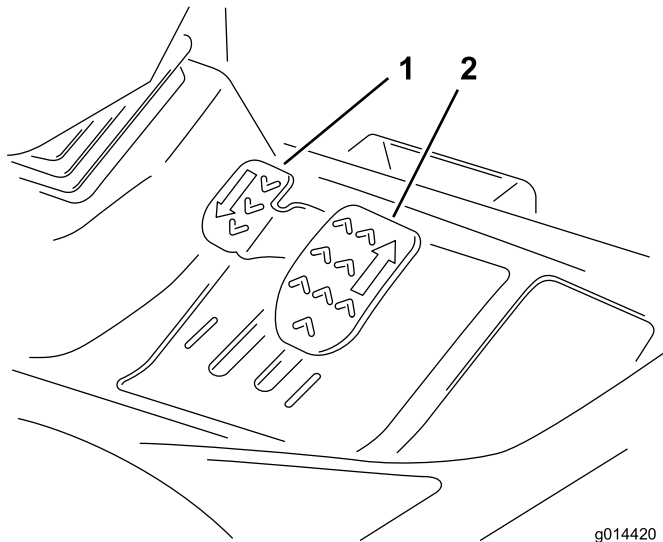

**Figure 5**

g014420

1. Reverse-travel pedal      2. Forward-travel pedal

## Braking System

### Parking Brake

Move the parking-brake switch to its forward position by depressing the smaller locking button and moving the switch forward to engage the parking brake (Figure 6).

**Note:** Do not operate the mower with the parking brake engaged and do not engage the parking brake while the mower is moving.

This light illuminates when the parking brake is engaged and the ignition key is turned to position I.

### **⚠ WARNING**

The parking brake operates on the front wheels only.

Do not park the mower on a slope.

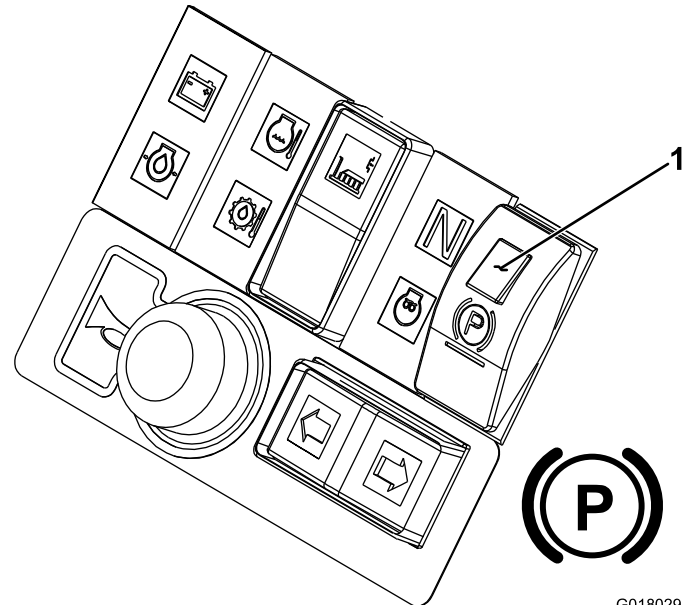

**Figure 6**

G018029

1. Parking brake

### Service Brake

Service braking is achieved by the hydraulic transmission system. When the forward or reverse travel pedals are released or the engine speed reduced, service braking becomes effective and travel speed is automatically reduced. To increase the braking effect, push the transmission pedal into the neutral position. Service braking is effective on the front wheels only.

### **⚠ WARNING**

The service braking system will not hold the mower at a standstill.

*Always ensure that the parking brake is engaged to park the mower at a standstill.*

### Emergency Brake

In the event of service brake failure, turn the ignition off to bring the mower to a stand still.

### **⚠ WARNING**

Take care when using the emergency braking.

Remain seated and hold on to the steering wheel to prevent ejection from the mower caused by the front wheel brakes being applied suddenly when travelling.

## Throttle Control

Operate the throttle control in a forward direction to increase the engine speed. Operate the throttle control in a rearward direction to reduce engine speed (Figure 7).

**Note:** The engine speed dictates the speed of the other functions (i.e., travel, cutting-blade rotation speed and cutting unit lift speed).

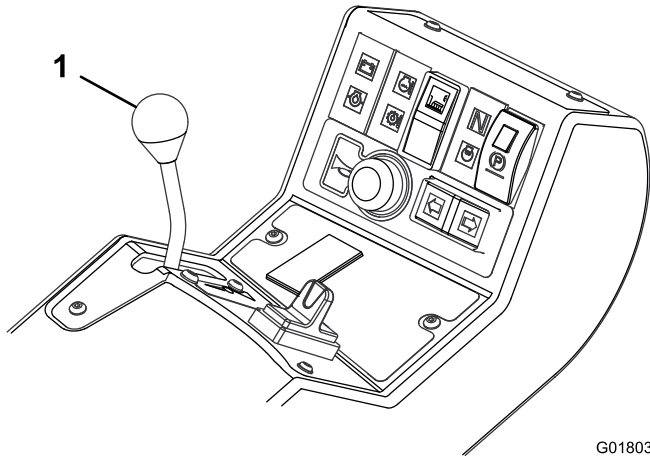
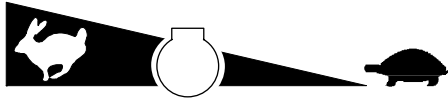

Figure 7

G018034

1. Throttle control

## Travel

**Forward travel:** Press the forward travel pedal to increase forward-travel speed. Release the pedal to reduce speed (Figure 8).

**Reverse travel:** Press the reverse travel pedal to increase reverse-travel speed. Release the pedal to reduce speed (Figure 8).

**Stop (Neutral):** Release the forward or reverse travel pedal.

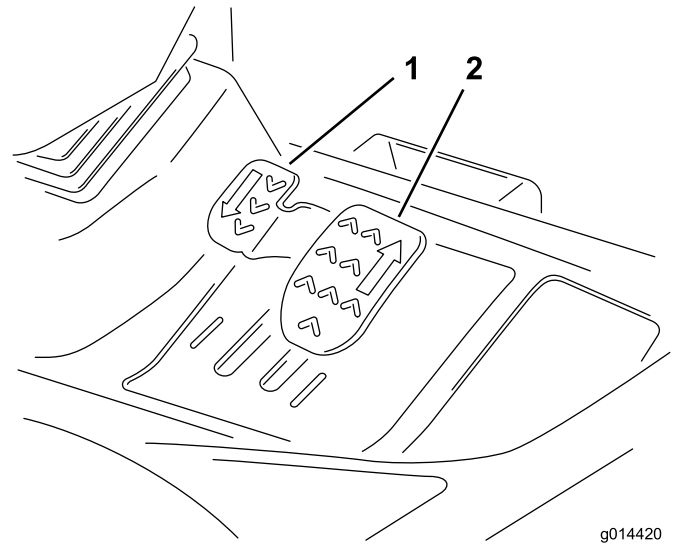

Figure 8

g014420

1. Reverse travel pedal
2. Forward travel pedal

## Cutting-Unit Drive Switch

Always put the cutting unit drive switch in the OFF position when travelling between work areas.

## Adjustable-Steering Column

### ⚠ WARNING

Never operate the mower without first checking that the steering column adjuster mechanism is in good working order and that, once adjusted and locked, the steering wheel remains securely in position.

**The operator may lose control causing injury or property damage.**

Adjustment of the steering wheel and steering column should only be carried out when the mower is at a standstill with the parking brake engaged.

1. To tilt the steering wheel, press the foot pedal down.
2. Position the steering tower to the most comfortable position and release the pedal (Figure 9).



G014549

Figure 9

## Operator Seat

### ▲ WARNING

Never operate the mower without first checking that the operator seat mechanisms are in good working order and that, once adjusted and locked, the seat remains securely in position.

Adjustment of the seat mechanisms should only be carried out when the mower is at a standstill with the parking brake engaged.

The operator may lose control causing injury or property damage.

**Fore/Aft Adjustment:** The seat-adjustment lever allows you to adjust the seat forward and rearward (Figure 10).

**Operator weight adjustment:** Rotate the handle clockwise to increase suspension stiffness and counter-clockwise to decrease it (Figure 10).



Figure 10

G018093

1. Seat-adjustment lever
2. Operator-weight handle

# Warning Systems

## Engine-Coolant Overheating Warning Light

The engine-coolant warning light illuminates, the mower deck stops, and the horn is actuated (Figure 11).

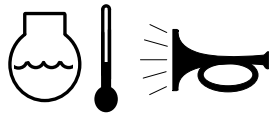
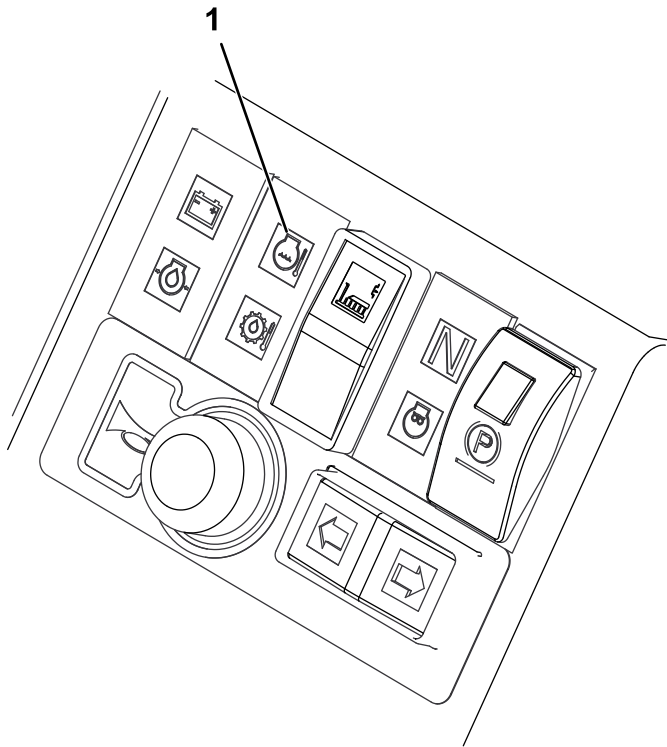

Figure 11

G018035

- 1. Engine-coolant overheating warning light

## Hydraulic-Fluid Overheating Warning Light and Horn

The hydraulic-fluid warning light illuminates when overheating occurs. The horn is actuated when the hydraulic fluid in the reservoir exceeds 95 degrees C (203 degrees F) as shown in Figure 12.

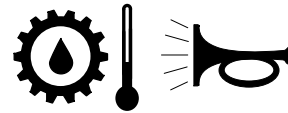
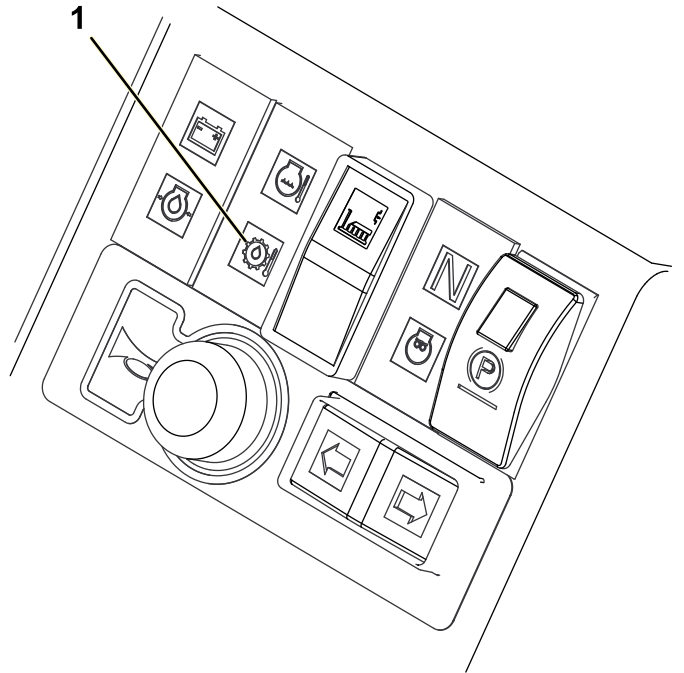

Figure 12

G018036

- 1. Hydraulic-oil overheating warning light

### Low Battery-Charge Warning Light

The battery-charge warning light illuminates when the low battery charge is low (Figure 13).

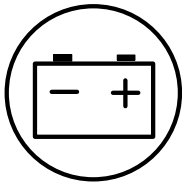
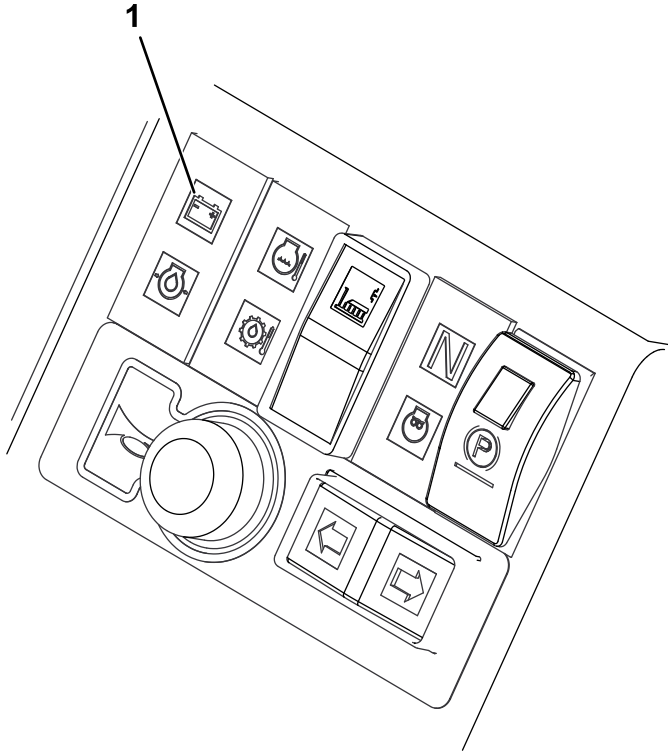

**Figure 13**

1. Low battery-charge warning light

G018037

### Low Engine-Oil Pressure Warning Light

The engine-oil pressure warning light illuminates when the oil pressure is too low (Figure 14).

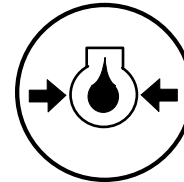
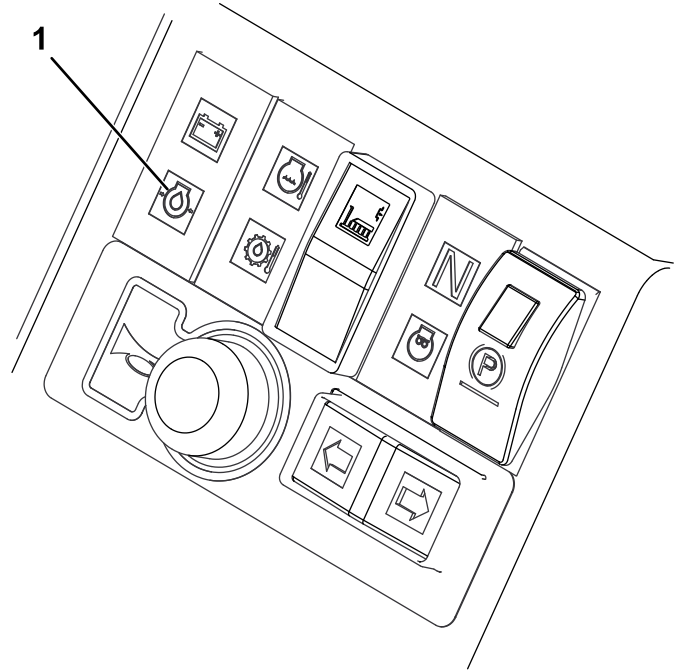

**Figure 14**

1. Low engine oil pressure warning light

G018081

## Ignition Key

0 = Engine off
I = Engine run/Auxiliary on
II = Engine pre-heat
III = Engine start

### ⚠ CAUTION

If you leave the key in the ignition switch, someone could accidentally start the engine and seriously injure you or other bystanders.

Lower the cutting units to the ground, set the parking brake and remove the key from the ignition switch before servicing or making adjustments to the machine.

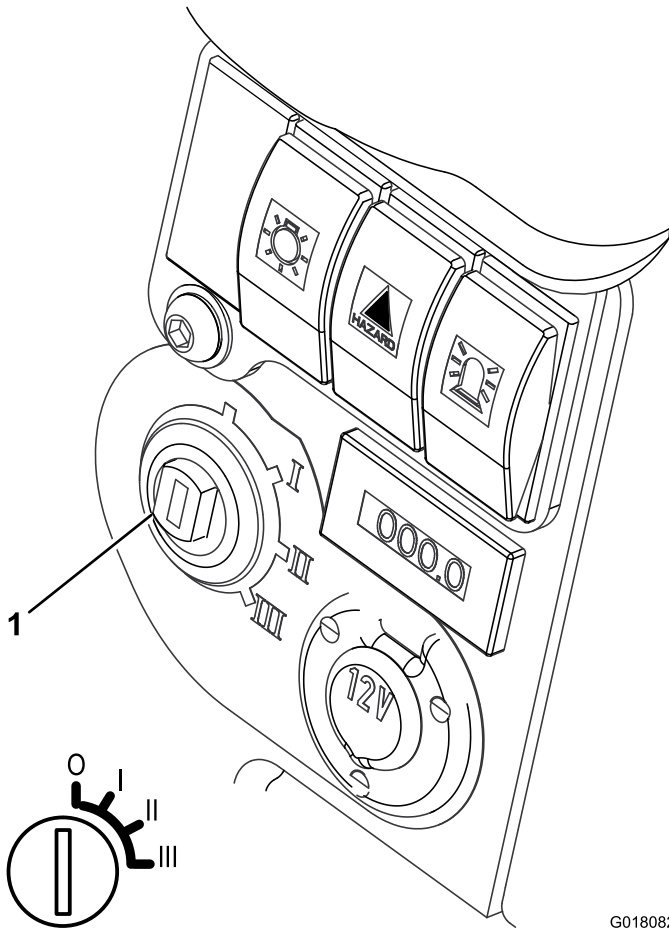

Figure 15

G018082

1. Ignition switch

## Engine Pre-Heat Indicator Light

Turn the ignition key to position **II**. The engine pre-heat indicator light will illuminate and heat the glow plugs (Figure 16).

**Important:** Attempting to start a cold engine before using the pre-heat can cause unnecessary wear to the battery.

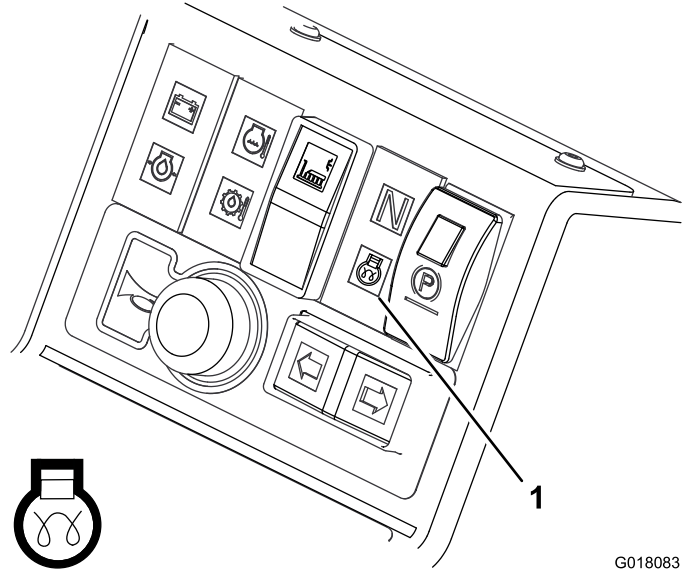

Figure 16

G018083

1. Engine pre-heat indicator light

## Fuel Gauge

The fuel gauge shows the amount of fuel in the tank (Figure 17).

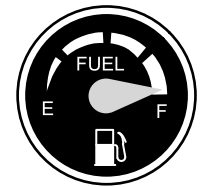

G014558

Figure 17

## Hour Meter

The hour meter shows the total hours that the machine has been operated (Figure 18).

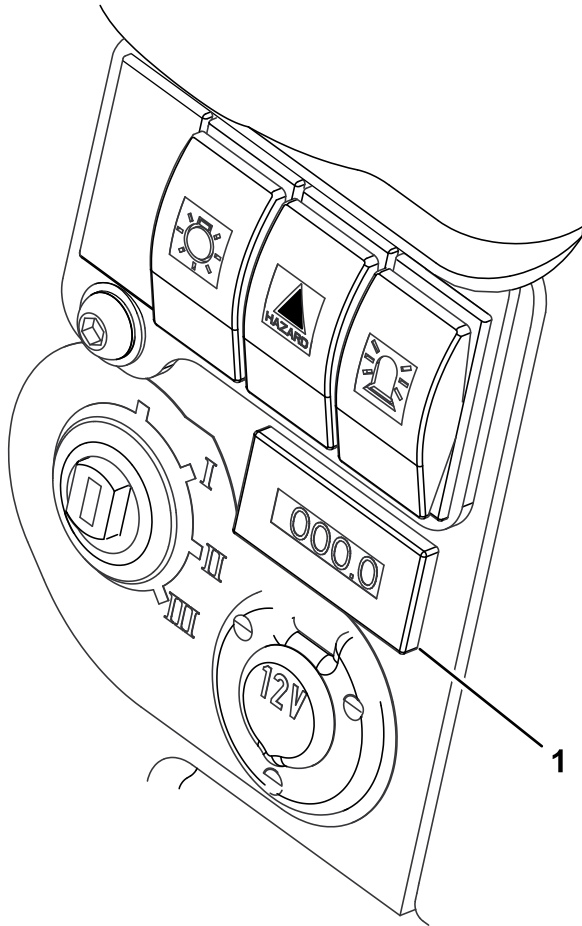

Figure 18

G018084

1. Hour meter

## Transmission Neutral-Indicator Light

This light illuminates when the travel control pedal is in the NEUTRAL position and the ignition key is turned to position I (Figure 19).

**Note:** The parking brake must be engaged for the transmission neutral-indicator light to illuminate.

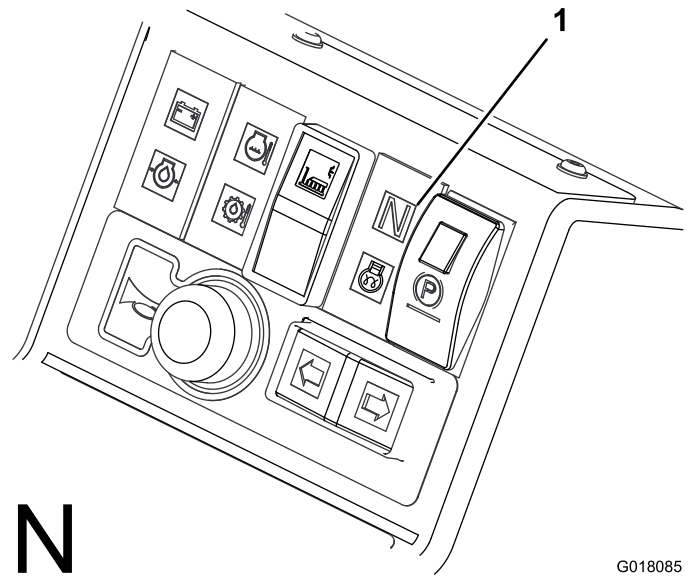

Figure 19

G018085

1. Transmission neutral-indicator light

## Cutting Unit Drive-Switch Indicator Light

This light illuminates when the cutting-unit-drive switch is in the FORWARD position and the ignition key is turned to position I (Figure 20).

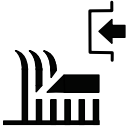
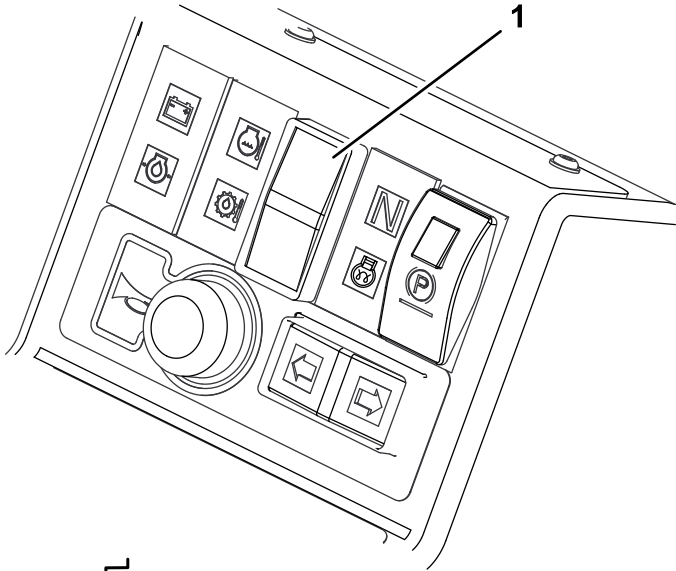

**Figure 20**

G029106

1. Indicator light for the cutting-unit-drive switch
-

# Specifications

**Note:** Specifications and design are subject to change without notice.

Width	1,490 mm (58.7 inches)
Length	2,410 mm (94.9 inches)
Height	1681 mm (66.2 inches) with ROPS folded 2160 mm (85 inches) with ROPS in its vertical operating position
Weight (without cutting unit)	880 kg (1940 lb)
Fuel-tank capacity	45.7 L (10 UK gallons)
Maximum forward speed	25 km/h (15.5 mph)
Maximum reverse speed	12.5 km/h (8 mph)
Hydraulic-system capacity	32 L (7.04 UK gallons)
Engine	Kubota 26.5 kw (35.5 hp) at 2000 rpm DIN 70020

## Attachments/Accessories

A selection of Toro approved attachments and accessories are available for use with the machine to enhance and expand its capabilities. Contact your Authorized Service Dealer or Distributor.

# Operation

**Note:** Determine the left and right sides of the machine from the normal operating position.

## ⚠ CAUTION

If you leave the key in the ignition switch, someone could accidentally start the engine and seriously injure you or other bystanders.

Lower the cutting units to the ground, set the parking brake, and remove the key from the ignition switch before servicing or making adjustments to the machine.

## Checking the Engine-Oil Level

**Service Interval:** Before each use or daily

The engine is shipped with oil in the crankcase; however, the oil level must be checked before and after the engine is first started.

Crankcase capacity is 6 L (203 oz) with the filter.

Use high-quality engine oil that meets the following specifications:

- API Classification Level Required: CH-4, CI-4 or higher
- Preferred oil: SAE 15W-40 above -18 degrees C (above 0 degrees F)
- Alternate oil: SAE 10W-30 or 5W-30 (all temperatures)

Toro Premium Engine oil is available from your distributor in either 15W-40 or 10W-30 viscosity.

**Note:** The best time to check the engine oil is when the engine is cool before it has been started for the day. If it has already been run, allow the oil to drain back down to the sump for at least 10 minutes before checking. If the oil level is at or below the **add** mark on the dipstick, add oil to bring the oil level to the **full** mark. **Do not overfill.** If the oil level is between the **full** and **add** marks, no oil addition is required.

1. Park the machine on a level surface, stop the engine, set the parking brake and remove the key from the ignition switch.
2. Open the hood.
3. Remove the dipstick, wipe it clean, and install it (Figure 21).

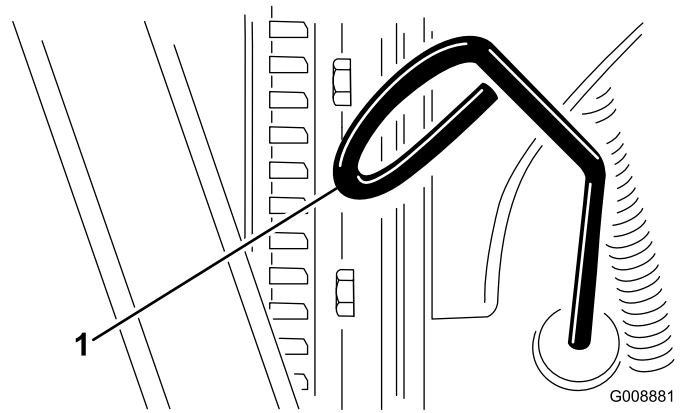

Figure 21

1. Dipstick

4. Remove dipstick and check oil level on dipstick. The oil level should be up to the FULL mark.
5. If the oil level is below the Full mark, remove the fill cap (Figure 22) and add oil until the level reaches the FULL mark on dipstick. **Do not overfill.**

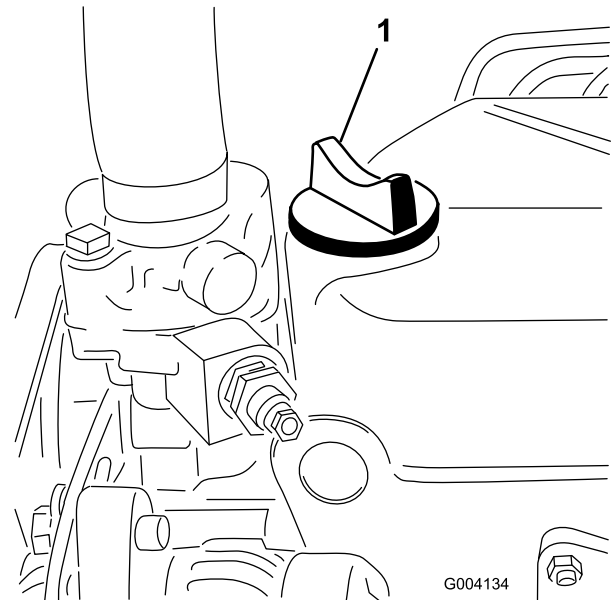

Figure 22

1. Oil fill cap

6. Install the oil-fill cap and close the hood.

# Checking the Cooling System

**Service Interval:** Before each use or daily

## ⚠ CAUTION

If the engine has been running, the pressurized, hot coolant can escape and cause burns.

- Do not open the radiator cap when the engine is running.
- Use a rag when opening the radiator cap, and open the cap slowly to allow steam to escape.

The cooling system is filled with a 50/50 solution of water and permanent ethylene glycol antifreeze.

1. Clean any debris off of the screen, oil cooler, and the front of the radiator daily and more often if conditions are extremely dusty and dirty. Refer to [Removing Debris from the Cooling System](#) (page 40).
2. Check the level of the coolant in the expansion tank ([Figure 23](#)).

**Note:** Check and ensure the coolant level is between the marks on the side of the tank.

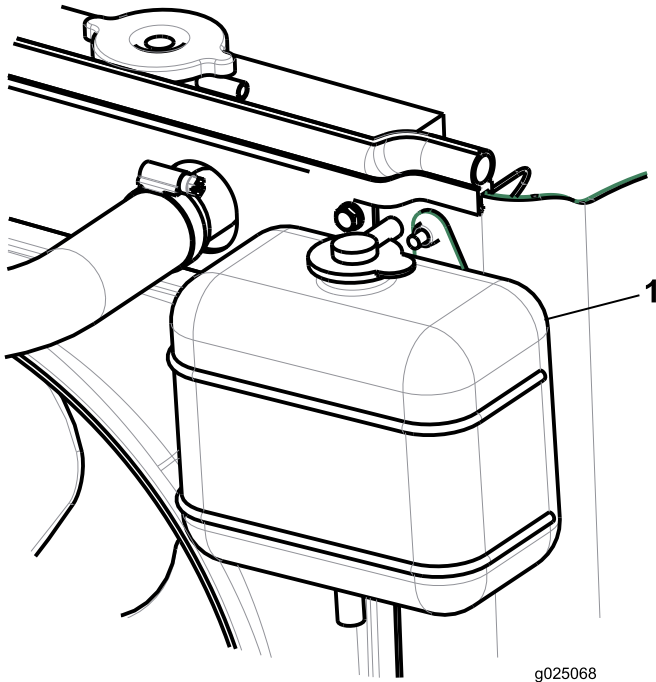

Figure 23

1. Expansion tank
3. If the coolant level is low, remove the expansion tank cap and replenish the system. Do not overfill.
4. Install the expansion tank cap.

## Adding Fuel

**Service Interval:** Before each use or daily

Use only clean, fresh diesel fuel with low (<501 ppm) or ultra low (<15 ppm) sulfur content. The minimum cetane rating is 40. To ensure fuel freshness, purchase fuel in quantities that is used within 180 days.

**Fuel tank capacity:** 25 L (10 UK gallons).

Use summer grade diesel fuel (No. 2-D) at temperatures above -7°C (20°F) and winter grade (No. 1-D or No. 1-D/2-D blend) below that temperature. The use of winter grade fuel at lower temperatures provides lower flash point and cold flow characteristics which will ease starting and reduce fuel filter plugging.

The use of summer grade fuel above -7°C (20°F) will contribute toward longer fuel pump life and increased power compared to winter grade fuel.

**Important:** Do not use kerosene or gasoline instead of diesel fuel. This product is suitable for use with Biodiesel of up to B7. Failure to observe this caution will damage the engine.

## ⚠ WARNING

Fuel is harmful or fatal if swallowed. Long-term exposure to vapors can cause serious injury and illness.

- Avoid prolonged breathing of vapors.
- Keep face away from nozzle and gas tank or conditioner opening.
- Keep fuel away from eyes and skin.

## ⚠ DANGER

In certain conditions, fuel is extremely flammable and highly explosive. A fire or explosion from fuel can burn you and others and can damage property.

- Fill the fuel tank outdoors, in an open area, when the engine is cold. Wipe up any fuel that spills.
- Never fill the fuel tank inside an enclosed trailer.
- Never smoke when handling fuel, and stay away from an open flame or where fuel fumes may be ignited by a spark.
- Store fuel in an approved container and keep it out of the reach of children. Never buy more than a 30-day supply of fuel.
- Do not operate without entire exhaust system in place and in proper working condition.



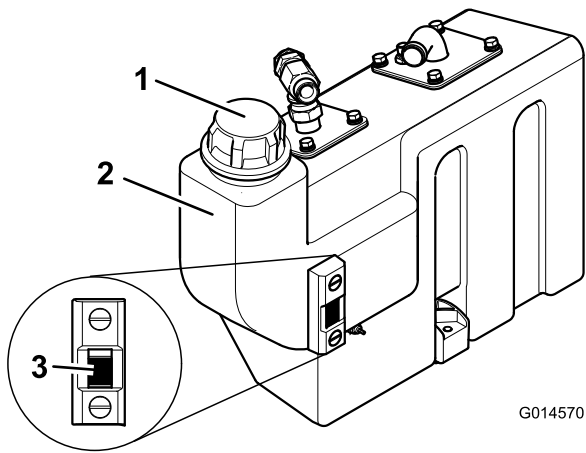

**Figure 24**

- 1. Hydraulic-tank cap
- 2. Oil tank
- 3. Sight-level gauge

5. Remove the cap and fill the tank to the upper mark on the sight level gauge. Do not overfill.
6. Install the cap onto the tank.

## Checking the Wheel Nut Torque

**Service Interval:** Before each use or daily

Torque the wheel nuts to 200 N·m (148 ft-lb) for the front axle, and 54 N·m (40 ft-lb) for the rear axle.

### **▲ WARNING**

Failure to maintain proper torque of the wheel nuts could result in personal injury.

## Using the Platform-Latching Mechanism

Do not operate the mower without first checking that the platform-latching mechanism is fully engaged and in good working order.

### **▲ WARNING**

Never operate the mower without first checking that the operator platform latching mechanism is fully engaged and in good working order.

## Releasing the Platform

1. Move the locking handle towards the front of the mower until the latch hooks clear the locking bar.
2. Raise the platform. The gas spring will provide assistance.

## Securing the Platform

1. Lower the platform carefully. The gas spring will provide assistance.
2. Move the locking handle towards the front of the mower as the platform nears the fully lowered position.
 

**Note:** This will ensure that the latch hooks clear the locking bar.
3. Lower the platform and move the locking handle towards the rear of the mower until the latch hooks engage the locking bar.

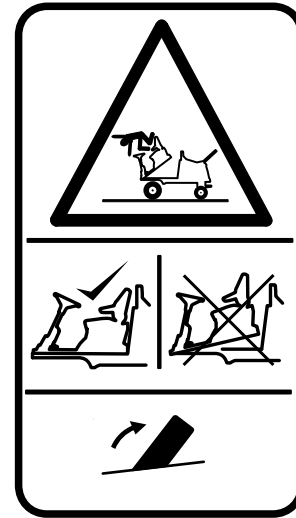

**Figure 25**

## Understanding the Operator-Presence Control

**Note:** The engine will turn off when you leave the seat without engaging the parking brake.

**Engine Start Lockout:** The engine starts only when the forward/reverse travel pedal is in the NEUTRAL position, the cutting unit switch is in the OFF position, and the parking brake is engaged. When these circumstances are satisfied, the engine will start.

**Engine Run Interlock:** While the engine is running, you must stay seated before releasing the parking brake.

**Cutting Unit Drive Lockout:** The cutting units only engage when you are seated. The cutting units disengage when you rise from the seat for more than 1 second. To engage cutting unit, you must return to the seat and move the cutting unit drive switch to the OFF position before moving it back to the ON position.

**Note:** If you rise from the seat for a brief moment during normal work, the cutting unit is not affected.

You can start the engine only with the cutting-unit switch in the OFF position.

## ⚠ WARNING

Do not operate the mower if the operator-presence controls are not functioning.

Always replace parts that are not functioning and check that they function correctly before operating the mower.

## ⚠ CAUTION

If the safety-interlock switches are disconnected or damaged, the machine could operate unexpectedly, causing personal injury.

- Do not tamper with the interlock switches.
- Check the operation of the interlock switches daily and replace any damaged switches before operating the machine.

## Starting and Stopping the Engine

**Important:** You must bleed the fuel system before starting the engine if you are starting the engine for the first time, the engine has stopped due to lack of fuel, or you have performed maintenance on the fuel system; refer to [Bleeding the Fuel System \(page 36\)](#).

## ⚠ WARNING

Before starting the engine check that:

- You have read and understood the Safety Precautions section in this manual.
- The area is clear of bystanders.
- The cutting unit drive is disengaged.
- The parking brake is engaged.
- The travel control pedals are in neutral.

**Important:** This machine is fitted with an engine-start lockout, refer to [\(page \)](#)

## Starting a Cold Engine

1. Sit in the seat, keep your foot off the traction pedals to ensure they are in the NEUTRAL position, engage the parking brake, and set the throttle to the 70 percent full throttle position.
2. Turn the ignition key to the ON position (I) and check that the engine oil pressure and battery-charge-warning lights illuminate.
3. Turn the ignition key to the PREHEAT position (II) and ensure the pre-heat indicator light is on. Hold it for 5 seconds to heat the glow plugs.

4. After preheating the glow plugs, turn key to the START position (III) and hold it to start the engine.

**Note:** Crank the engine for no longer than 15 seconds.

5. Release the ignition key back to the ON position (I) when the engine starts.
6. Run the engine at low idle speed until it warms up.

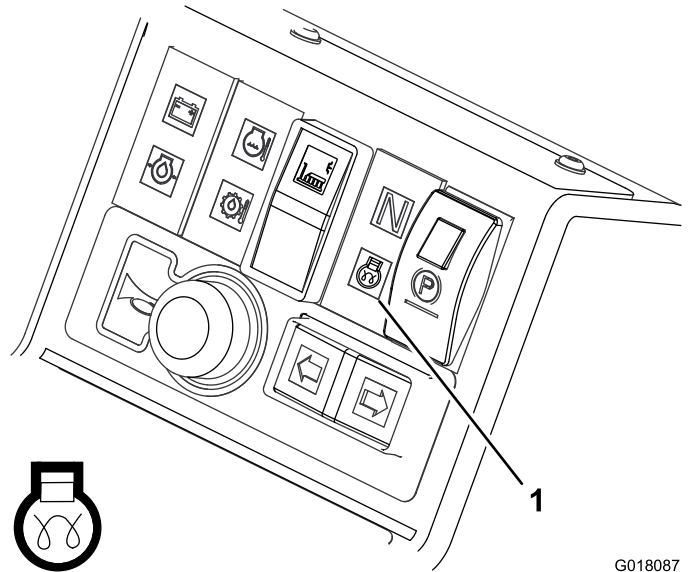

Figure 26

G018087

1. Engine pre-heat indicator light

## ⚠ WARNING

When the engine is operating, all warning lights should be off. If a warning light illuminates, stop the engine immediately and have the fault rectified before starting the machine.

Damage to the engine could occur if the fault is not rectified.

## Starting a Warm Engine

1. Sit in the seat, keep your foot off of the traction pedals to ensure they are in the NEUTRAL position, engage the parking brake, and set the throttle to the 70 percent full throttle position.
2. Turn the ignition key to the ignition the ON position (I) and check that the engine oil pressure and battery-charge-warning lights illuminate.
3. Turn the ignition key to the START position (III) and hold it to start the engine.

**Note:** Crank the engine for no longer than 15 seconds.

4. Release the ignition key back to the ON position (I) when the engine starts.
5. Run the engine at low idle speed until it warms up.

## Stopping the Engine

1. Move all controls to the NEUTRAL position, set the parking brake, move the throttle to the low-idle position, and allow the engine to reach low-idle speed.

**Important:** Allow the engine to idle for 5 minutes before shutting it off after a full load operation. Failure to do so may lead to trouble on a turbo-charged engine.

2. Let the engine idle for 5 minutes.
3. Turn the ignition key to the OFF position (0).

If the engine fails to stop when the ignition key is turned to the OFF position (0), move the engine-stop lever forward (Figure 27).

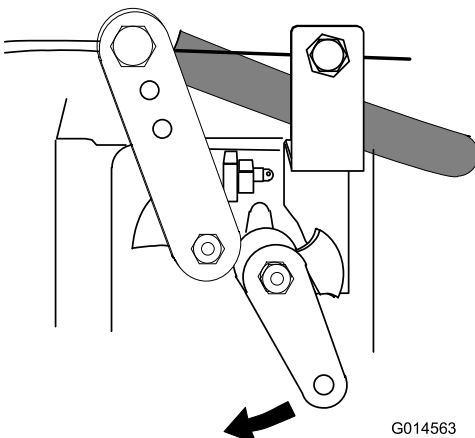

Figure 27

## Using Cutting-Unit Position Control

Use the lift-control switch to raise or lower the cutting unit.

1. To lower the cutting unit, operate the lift control switch in a downward direction and release.

The cutting unit is now in the Float mode and will follow the ground contours.

2. To raise the cutting unit, press the lift-control switch in the upward direction and hold it.
3. Release the lift-control switch when the cutting unit is at the required height.

The control switch will automatically return to the NEUTRAL position and the arms are hydraulically locked into position.

## Engaging the Cutting Unit Drive

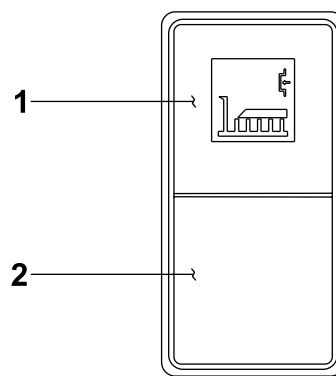

Figure 28

1. On
2. Off

The cutting unit engages only when you are in the seat correctly, refer to [Operating the Presence Seat Switch \(page 43\)](#).

**Cutting-unit-drive engagement:** Press the top of the cutting-unit-drive switch to the FORWARD position.

**Cutting-unit-drive disengagement:** Press the bottom of the cutting-unit-drive switch to the REARWARD position.

## Using the Weight Transfer/Traction Assistance

A hydraulic weight-transfer system is provided for improving traction with the terrain.

Weight transfer is using the cutting-unit hydraulic pressure in the lift system to provide a lifting force to reduce the cutting-unit weight on the ground and transfers the weight as a downward force onto the tires.

The amount of weight transfer is variable to suit operating conditions by rotating the weight-transfer hand wheel as follows:

1. Release the valve lock nut 1/2 turn counter-clockwise and hold.
2. Rotate the valve hand wheel.
  - Rotate counterclockwise to reduce the weight transfer.
  - Rotate clockwise to increase the weight transfer.
3. Tighten the nut.

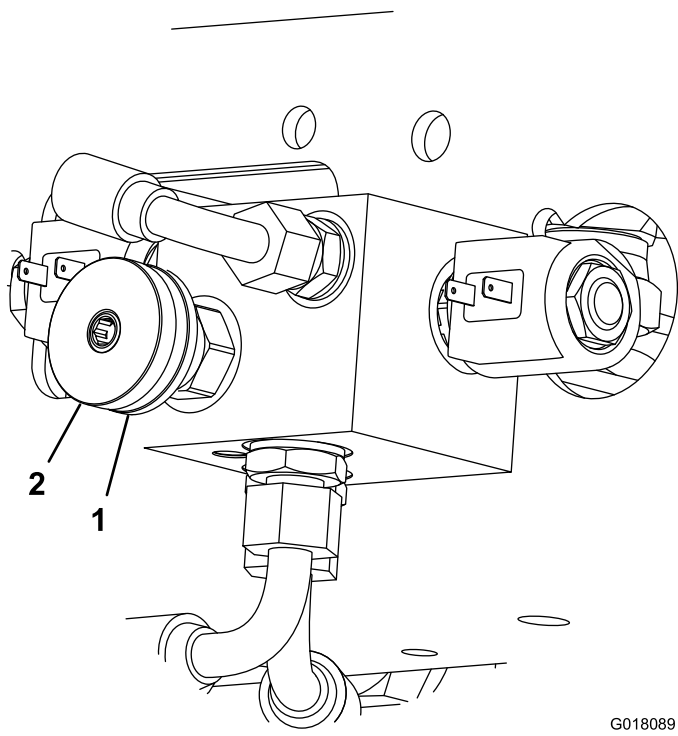

Figure 29

1. Lock wheel
2. Weight-transfer hand wheel

## Folding the ROPS

You can fold the ROPS frame to allow access into areas of restricted height.

### ⚠ WARNING

There is no roll-over protection when the roll bar is folded in the down position.

- Lower the roll bar only when absolutely necessary.
- Do not wear the seat belt when the roll bar is in the down position.
- Drive slowly and carefully.
- Raise the roll bar as soon as clearance permits.
- Check carefully for overhead clearance (i.e., branches, doorways, electrical wires) before driving the machine under any objects; do not contact them.

1. Apply the parking brake and switch off the engine.
2. Support the weight of the roll bar while removing the hand nuts, washers and retaining bolts from the pivot brackets (Figure 30).
3. Carefully lower the frame downward until it rests on the stops.

4. Insert the retaining bolts in the lower hole and fully tighten the hand nuts to support the roll bar in its lowered position.
5. To raise the frame, follow these instructions in reverse order.

### ⚠ WARNING

If the ROPS is not properly installed or fully tightened, it will not provide full protection in the event of a roll-over.

When the roll bar is in the raised position, ensure that both retaining bolt assemblies are installed and fully tightened.

### ⚠ WARNING

If you are not careful when lowering or raising the roll bar, you can entrap and seriously injure your fingers.

Be careful lowering and raising the roll bar to prevent entrapment of fingers between the fixed part and the pivot part of the structure.

- Keep all nuts, bolts, and screws torqued correctly to ensure that the equipment is in safe working condition.
- Replace worn or damaged parts for safety.
- Ensure that the seat belt and mountings are in safe working order.

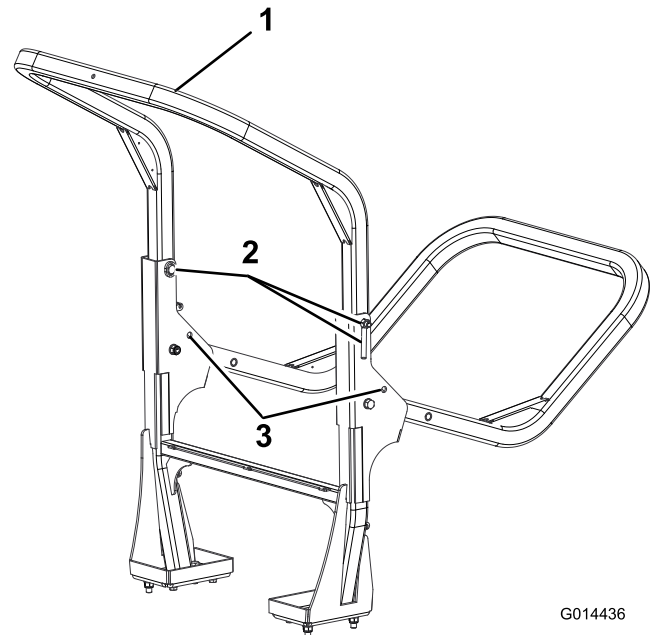

Figure 30

1. Roll bar
2. Hand nuts, washers, and retaining bolts
3. Lower hole

# Jacking Points

**Note:** Use jack stands to support the machine when required (Figure 31).

- Front—under the rear lift cylinder mount.
- Rear—axle tube on the rear axle.

## Raising The Mower off the Ground

### ⚠ WARNING

A raised mower deck that is not properly supported can fall, crushing you or bystanders who are underneath it.

When the mower is raised off the ground:

- Never crawl under the mower.
- Never start the engine.

**Important:** Before raising the mower ensure that the lifting device to be used is in good condition and capable of supporting the weight of the mower securely. Minimum lift capacity: 2 Tonnes (4,409 lb).

1. Park the mower on level ground.
2. Set the parking brake.
3. Turn the engine switch to the OFF position and remove the ignition key.
4. Ensure the ground under the lifting device is level and firm.
5. Align and ensure the lifting device is secure against 1 of the mowers lifting points.
6. If raising the front of the mower, chock the rear wheels to prevent the mower rolling away.

**Note:** The parking brake only operates on the front wheels.

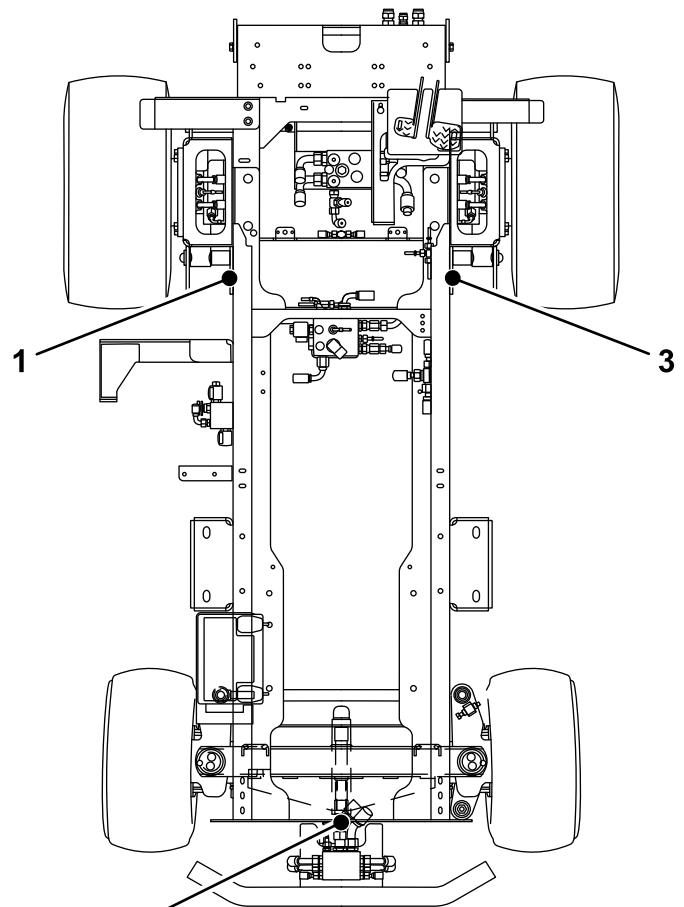

G018092

**Figure 31**

1. Front-lifting point
2. Rear-lifting point
3. Front, right lifting point

# Transporting Machines

## **⚠ WARNING**

**Driving on the street or roadway without turn signals, lights, reflective markings, or a slow moving vehicle emblem is dangerous and can lead to accidents causing personal injury.**

**Do not drive machine on a public street or roadway without signs, lights, and/or markings required by local regulations.**

Use a heavy-duty trailer or truck to transport the machine. Ensure that the trailer or truck has all necessary lighting and marking as required by law. Please carefully read all the safety instructions. Knowing this information could help you or bystanders avoid injury.

To transport the machine:

- Ensure that your vehicle, hitch, safety chains, and trailer are adequate for the load you are pulling and that they meet all local traffic regulations for your area.
- Lock the brake and block the wheels.
- Securely fasten the machine to the trailer or truck with straps, chains, cable, or ropes as required by local traffic regulations in your area.

# Operating Tips

## Familiarization

Before mowing grass, practice operating the machine in an open area. Start and stop the engine. Operate the machine in forward and reverse. Lower and raise the cutting unit and engage and disengage the cutting unit. When you feel familiar with the machine, practice operating it up and down slopes at different speeds.

## Warning System

If a warning light comes on during operation, stop the machine immediately, and correct the problem before continuing operation. Serious damage could occur if you operate the machine with a malfunction.

## Mowing

The speed of the cutting unit blades should always be kept as high as possible in order to maintain the highest quality of cut. This in turn requires that the engine speed be kept as high as possible.

Cutting performance is best when cutting against the lie of the grass. You should attempt to alternate the direction of mowing between cuts.

# Quality of Cut

The quality of cut will deteriorate if the forward speed is excessive. Always balance the quality of cut with the work rate required and set the forward speed accordingly.

## Engine

Never let the engine labor. Reduce the forward speed or increase the height of cut.

## Transporting

Always disengage the cutting unit drive when travelling across un-grassed areas. Be careful when driving between objects so that you do not accidentally damage the machine or cutting units.

**Important: Take care when travelling over obstacles, such as roadside curbs. Always travel at a slow speed over obstacles to prevent damage to the tires, wheels, and steering system. Ensure that tires are inflated to the recommended pressures.**

## Slopes

Use extra care when operating the machine on slopes. Drive slowly and avoid sharp turns on slopes to prevent roll overs. Lower the cutting unit when going downhill for steering control.

# Maintenance

**Note:** Determine the left and right sides of the machine from the normal operating position.

**Note:** Download a free copy of the schematic by visiting [www.Toro.com](http://www.Toro.com) and searching for your machine from the Manuals link on the home page.

## Recommended Maintenance Schedule(s)

Maintenance Service Interval	Maintenance Procedure
After the first 8 hours	<ul style="list-style-type: none"> <li>• Check the condition and tension of the alternator belt.</li> </ul>
After the first 50 hours	<ul style="list-style-type: none"> <li>• Change the engine oil and filter.</li> <li>• Change the transmission-oil filter.</li> <li>• Change the hydraulic-fluid-return filter.</li> <li>• Check the engine speed (idle and full throttle).</li> </ul>
Before each use or daily	<ul style="list-style-type: none"> <li>• Check the engine-oil level.</li> <li>• Check the cooling system.</li> <li>• Check fuel level.</li> <li>• Check the hydraulic fluid level.</li> <li>• Torque the lug nuts.</li> <li>• Check the tire pressure.</li> <li>• Check the air cleaner blockage indicator. (Service the air cleaner earlier if the air cleaner indicator shows red. Service it more frequently in extremely dirty or dusty conditions.)</li> <li>• Remove debris from the screen, oil coolers, and radiator (more frequently in dirty operating conditions).</li> <li>• Check the safety-interlock system.</li> <li>• Check the hydraulic lines and hoses for leaks, kinked lines, loose mounting supports, wear, loose fittings, weather deterioration, and chemical deterioration.</li> </ul>
Every 50 hours	<ul style="list-style-type: none"> <li>• Grease the bearings, bushings, and pivots (Grease them immediately after every washing regardless of the interval listed.)</li> </ul>
Every 100 hours	<ul style="list-style-type: none"> <li>• Inspect the cooling system hoses.</li> <li>• Check the condition and tension of the alternator belt.</li> </ul>
Every 150 hours	<ul style="list-style-type: none"> <li>• Change the engine oil and filter.</li> </ul>
Every 200 hours	<ul style="list-style-type: none"> <li>• Drain moisture from the fuel and hydraulic fluid tanks.</li> </ul>
Every 250 hours	<ul style="list-style-type: none"> <li>• Check the battery condition.</li> <li>• Check the condition of and clean the battery.</li> <li>• Check the transmission control cable.</li> </ul>
Every 400 hours	<ul style="list-style-type: none"> <li>• Replace the fuel filter canister.</li> <li>• Check the fuel lines and connections.</li> <li>• Check the engine speed (idle and full throttle).</li> </ul>
Every 500 hours	<ul style="list-style-type: none"> <li>• Check the engine overheat-warning system.</li> <li>• Replace the primary air filter. (More frequently in extreme dusty or dirty conditions)</li> <li>• Check the electrical system.</li> <li>• Change the transmission-oil filter.</li> <li>• Change the hydraulic-fluid-return filter.</li> <li>• Check the rear wheel alignment.</li> <li>• Service the hydraulic system.</li> <li>• Check the hydraulic-fluid overheat warning system.</li> </ul>
Every 800 hours	<ul style="list-style-type: none"> <li>• Drain and clean the fuel tank.</li> <li>• Adjust the engine valves (refer to the engine Owner's Manual).</li> </ul>

Maintenance Service Interval	Maintenance Procedure
Before storage	<ul style="list-style-type: none"> <li>• Drain and clean the fuel tank.</li> </ul>
Every 2 years	<ul style="list-style-type: none"> <li>• Flush and replace the cooling system fluid.</li> <li>• Replace all moving hoses.</li> <li>• Replace the transmission cable.</li> </ul>

## Daily Maintenance Checklist

Duplicate this page for routine use.

Maintenance Check Item	For the week of:						
	Mon.	Tues.	Wed.	Thurs.	Fri.	Sat.	Sun.
Check the safety-interlock operation.							
Check the brake operation.							
Ensure that the ROPS is in the vertical/upright and locked position.							
Check the engine oil and fuel level.							
Check the air filter restriction indicator.							
Check the radiator and screen for debris.							
Check unusual engine noises. <sup>1</sup>							
Check for unusual operating noises.							
Check the hydraulic fluid oil level.							
Check the hydraulic hoses for damage.							
Check for fluid leaks.							
Check the tire pressure.							
Check the instrument operation.							
Check all grease fittings for lubrication. <sup>2</sup>							
Touch-up damaged paint.							
<p>1. Check the glow plug and injector nozzles if hard starting, excess smoke, or rough running is noted.</p> <p>2. Immediately after every washing, regardless of the interval listed</p>							

## Notation for Areas of Concern

Inspection performed by:		
Item	Date	Information
1		
2		
3		
4		
5		
6		
7		
8		

**Important:** Refer to your engine operator's manual for additional maintenance procedures.

# Pre-Maintenance

Before performing any maintenance, ensure that the engine is switched to the OFF position and that the ignition key is removed, the parking brake is set, there is no pressure in the hydraulic system, the cutting unit is down on the ground, and all safety precautions in this manual have been read and understood.

## **⚠ CAUTION**

If you leave the key in the ignition switch, someone could accidentally start the engine and seriously injure you or other bystanders.

Remove the key from the ignition before you do any maintenance.

**Important:** Regular maintenance is essential for the continued safe operation of the machine. Correct servicing will prolong the working life of the machine and safeguard the warranty. Always use genuine Toro service parts as these are accurately matched to the required duty.

Dirt and contamination are the enemies of any hydraulic system. When performing maintenance procedures on the hydraulic system, always ensure that the work area and the components are thoroughly clean before, during, and after procedure. Ensure that all open hydraulic lines and ports, etc., are plugged during maintenance procedures.

The recommended service intervals are based on normal operating conditions. Severe or unusual conditions will necessitate shorter service intervals.

Always grease the pivot points immediately after pressure washing or steam cleaning.

## **⚠ WARNING**

The engine, transmission oil, and hydraulic systems will be hot after machine use and can burn you and others.

Allow the systems to cool before working on the machine, particularly before working on the engine or when changing the oil or oil filters.

# Lubrication

## Greasing the Bearings, Bushings, and Pivots

Service Interval: Every 50 hours

Grease Type: No. 2 lithium or molybdenum grease

Lubricate bearings and bushings **immediately** after every washing, regardless of the interval listed.

Replace any damaged grease fittings.

Grease all grease points and ensure that sufficient grease is injected such that clean grease is seen to escape. This ensures maximum working life.

The grease fitting locations are as follows:

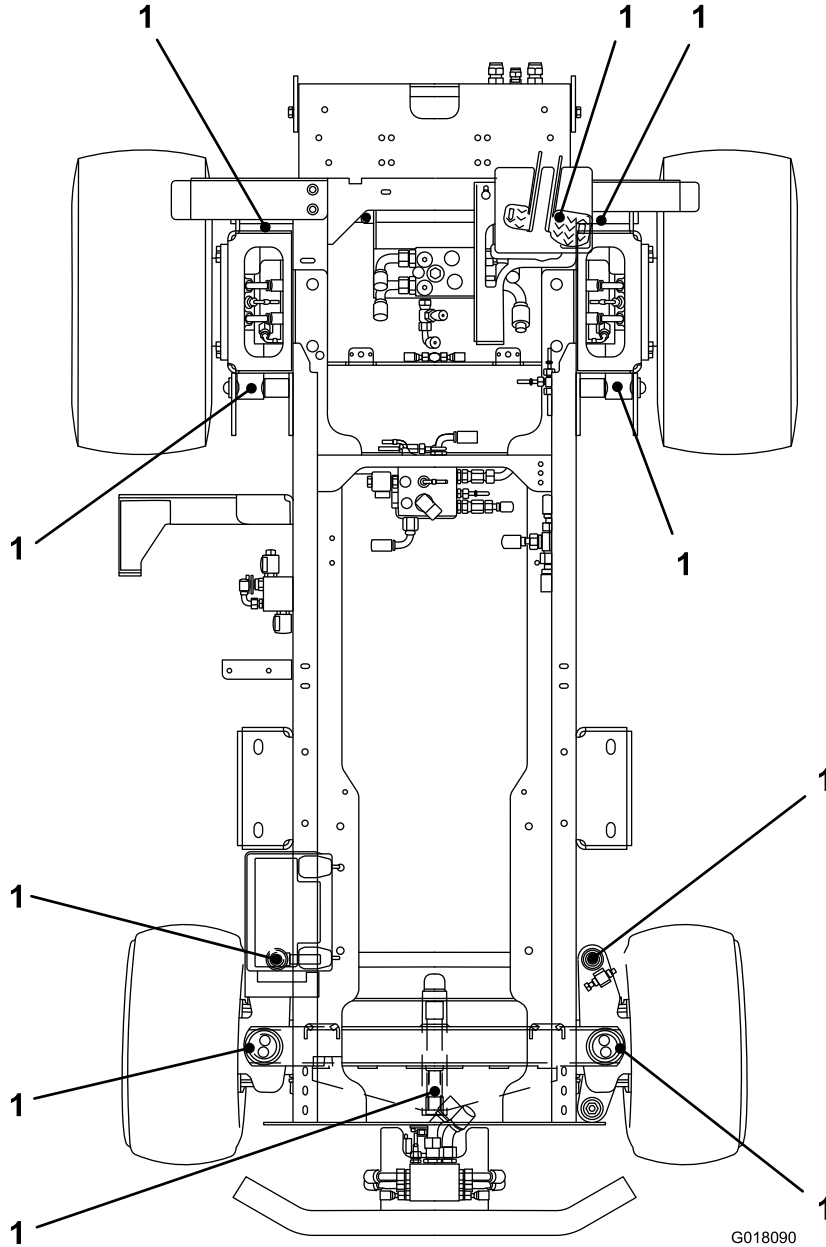

Figure 32

G018090

1. Grease every 50 hours

# Engine Maintenance

## Checking the Engine-Overheat-Warning System

**Service Interval:** Every 500 hours

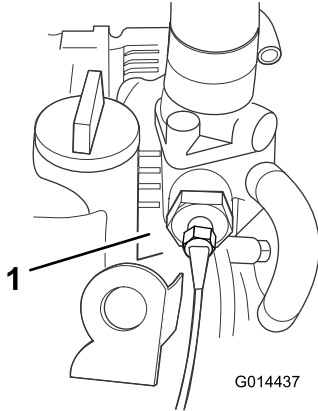

**Figure 33**

1. Temperature switch

1. Turn the ignition key to position I.
2. Disconnect the red/blue wire terminal from the engine-temperature switch.
3. Touch the metal terminal of this wire onto a suitable earth point, ensuring that the metal surfaces make good contact.

The horn will sound and the engine-coolant-temperature warning light will illuminate to confirm correct operation. If the system is not functioning, make repairs before operating the mower.

## Servicing the Air Cleaner

**Service Interval:** Before each use or daily  
Every 500 hours

### Servicing the Primary Air Filter

Check the air cleaner body for damage which could cause an air leak. Replace if damaged. Check the whole intake system for leaks, damage, or loose hose clamps.

Service the primary air cleaner filter only when the service indicator (Figure 34) requires it. Changing the air filter before it is necessary only increases the chance of dirt entering the engine when the filter is removed.

**Important:** Be sure that the cover is seated correctly and seals with the air cleaner body.

1. Check the filter-blockage indicator. If the indicator is red, replace the air filter (Figure 34).

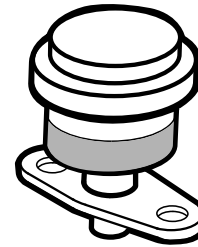
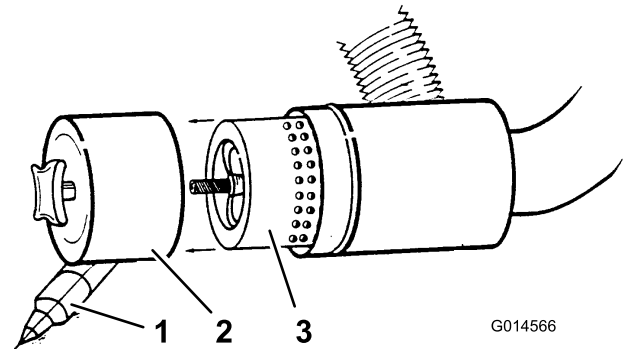

**Figure 34**

2. Before removing the filter, use low-pressure air (40 psi, clean and dry) to help remove large accumulations of debris packed between outside of the filter and the canister.

**Note:** Avoid using high-pressure air, which could force dirt through the filter into the intake tract.

**Note:** This cleaning process prevents debris from migrating into the intake when you remove the filter.



**Figure 35**

1. Dust boot
2. Dust bowl
3. Air filter

3. Remove the cover from the air-cleaner body.
4. Remove and replace the filter (Figure 35).

**Note:** Cleaning a used filter element could damage the filter media.

5. Inspect the new filter for shipping damage, checking the sealing end of the filter and the body.

**Note:** Do not use a damaged element.

6. Insert the new filter by applying pressure to the outer rim of the element to seat it in the canister.

**Note:** Do not apply pressure to the flexible center of the filter.

7. Clean the dirt ejection port located in the removable cover. Remove the rubber outlet valve from the cover, clean the cavity, and replace the outlet valve.

8. Install the cover orienting the rubber outlet valve in a downward position—between approximately 5 o'clock to 7 o'clock when viewed from the end.
9. Check the condition of the air cleaner hoses.
10. Secure the cover.

## Servicing the Safety Filter

The air filter has a secondary safety-filter element inside the primary air filter to prevent dislodged dust and other items from entering the engine while changing the main element.

**Important:** Replace the safety filter; never clean it. If the safety filter is dirty, then the primary filter is damaged. Replace both filters.

## Servicing the Engine Oil and Filter

**Service Interval:** After the first 50 hours

Every 150 hours

1. Remove the drain plug (Figure 36) and let the oil flow into a drain pan.

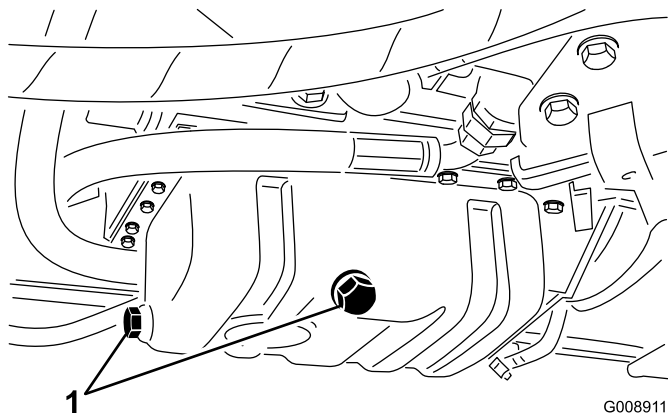

Figure 36

G008911

1. Oil drain plug

2. When the oil stops, install the drain plug.
3. Remove the oil filter (Figure 37).

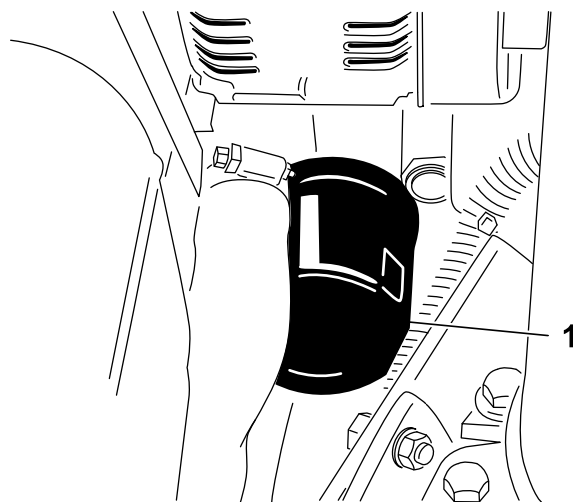

Figure 37

G008912

1. Oil filter

4. Apply a light coat of clean oil to the new filter seal.
5. Install the replacement oil filter to the filter adapter. Turn the oil filter clockwise until the rubber gasket contacts the filter adapter, then tighten the filter an additional 1/2 turn.

**Important:** Do not over-tighten the filter.

6. Add oil to the crankcase; refer to (page ).

# Fuel System Maintenance

## **▲ DANGER**

Under certain conditions, diesel fuel and fuel vapors are highly flammable and explosive. A fire or explosion from fuel can burn you and others and can cause property damage.

- Use a funnel and fill the fuel tank outdoors, in an open area, when the engine is off and is cold. Wipe up any fuel that spills.
- Do not fill the fuel tank completely full. Add fuel to the fuel tank until the level is 6 to 12 mm (1/4 to 1/2 inches) below the bottom of the filler neck. This empty space in the tank allows the fuel to expand.
- Never smoke when handling fuel, and stay away from an open flame or where fuel fumes may be ignited by a spark.
- Store fuel in a clean, safety-approved container and keep the cap in place.

## Replacing the Fuel Filter

**Service Interval:** Every 400 hours

**Important:** Replace the fuel filter canister periodically to prevent wear of the fuel injection pump plunger or the injection nozzle, due to dirt in the fuel.

1. Place a clean container under the fuel filter canister (Figure 38).
2. Clean the area where the filter canister mounts.

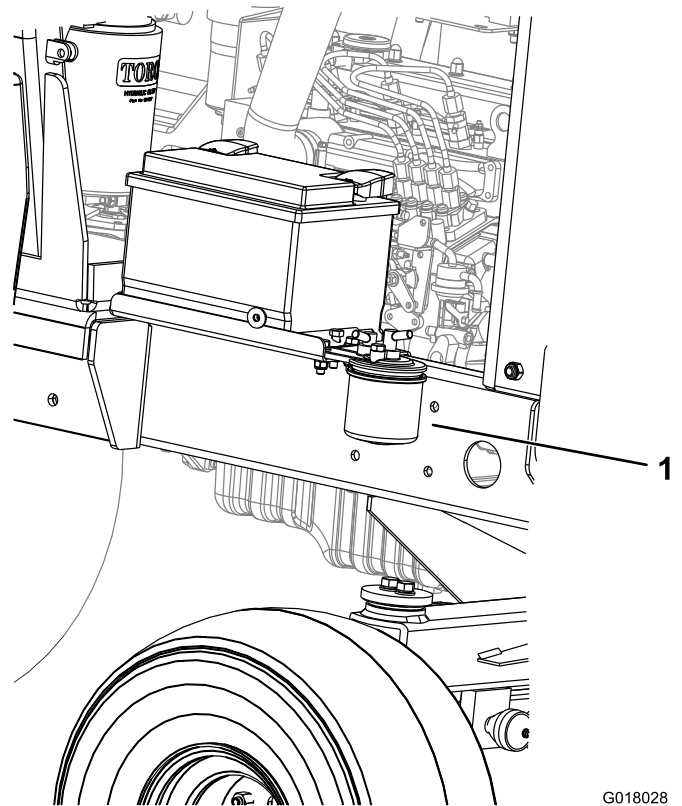

**Figure 38**

1. Fuel filter

3. Remove the filter canister and clean the mounting surface
4. Lubricate the gasket on the filter canister with clean oil.
5. Install the new filter canister by hand until the gasket contacts mounting surface.
6. Bleed the fuel system; refer to (page ).

## Bleeding the Fuel System

You must bleed the fuel system before starting the engine if any of the following situations have occurred:

- Initial start up of a new machine.
- Engine has ceased running due to lack of fuel.
- Maintenance has been performed upon fuel system components; i.e., filter is replaced, separator is serviced, etc.

## **▲ DANGER**

Under certain conditions, diesel fuel and fuel vapors are highly flammable and explosive. A fire or explosion from fuel can burn you and others and can cause property damage.

- Use a funnel and fill the fuel tank outdoors, in an open area, when the engine is off and is cold. Wipe up any fuel that spills.
  - Do not fill the fuel tank completely full. Add fuel to the fuel tank until the level is 6 to 12 mm (1/4 to 1/2 inches) below the bottom of the filler neck. This empty space in the tank allows the fuel to expand.
  - Never smoke when handling fuel, and stay away from an open flame or where fuel fumes may be ignited by a spark.
  - Store fuel in a clean, safety-approved container and keep the cap in place.
1. Park the machine on a level surface and ensure that the fuel tank is at least half full.
  2. Open the hood.
  3. Turn the key in the ignition switch to the ON position and crank the engine.

**Note:** The mechanical pump will suck fuel out of the tank, fill the fuel filter, and fuel hose and force the air into the engine. Time is needed to fully purge all the air out of the system and the engine might fire erratically until all air is purged out. When all air is purged and the engine is running smoothly, run the engine for a few minutes to ensure the air is fully purged.

## **Draining the Fuel Tank**

**Service Interval:** Every 800 hours

Before storage

Drain and clean the fuel tank if the fuel system becomes contaminated or if the machine is to be stored for an extended period. Use clean fuel to flush out the tank.

## **Checking the Fuel Lines and Connections**

**Service Interval:** Every 400 hours/Yearly (whichever comes first)

Check the fuel lines and connections. Inspect them for deterioration, damage, or loose connections.

## **Electrical System Maintenance**

**Important:** Before welding on the machine, disconnect both cables from the battery and the terminal connector from the alternator to prevent damage to the electrical system.

## **Checking the Electrical System**

**Service Interval:** Every 500 hours

Inspect all electrical connections and cables and replace any which are damaged or corroded. Spray a good quality water inhibitor onto exposed connections to keep moisture out.

## **Checking the Battery Condition**

**Service Interval:** Every 250 hours

**Note:** When removing the battery, always disconnect the negative (-) cable first.

**Note:** When installing the battery, always connect the negative (-) cable last.

Raise the engine cover. Remove any corrosion from the battery terminals using a wire brush and apply petroleum jelly to the terminals to prevent further corrosion. Clean the battery compartment.

Under normal operating conditions the battery does not require any further attention. If the machine has been subject to continuous use under high ambient temperature conditions, the battery electrolyte may require topping up.

Remove the cell covers and top up with distilled water to a height 15 mm (1/2 inch) below the top of the battery. Install the cell covers.

**Note:** Check the condition of the battery cables. Install new cables when current ones are showing signs of wear or damage and tighten any loose connections as necessary.

# Servicing the Battery

Service Interval: Every 250 hours

## **⚠ DANGER**

Battery electrolyte contains sulfuric acid, a deadly poison that can cause severe burns.

- Do not drink electrolyte and avoid contact with skin, eyes, or clothing. Wear safety glasses to shield your eyes and rubber gloves to protect your hands.
- Fill the battery where clean water is always available for flushing the skin.

## **⚠ WARNING**

Charging the battery produces gasses that can explode.

Never smoke near the battery and keep sparks and flames away from it.

Check the battery condition. Keep the terminals and the entire battery case clean because a dirty battery discharges slowly. To clean the battery, wash the entire case with a solution of baking soda and water. Rinse it with clear water.

# Drive System Maintenance

## Changing the Transmission-Oil Filter

Service Interval: After the first 50 hours

Every 500 hours

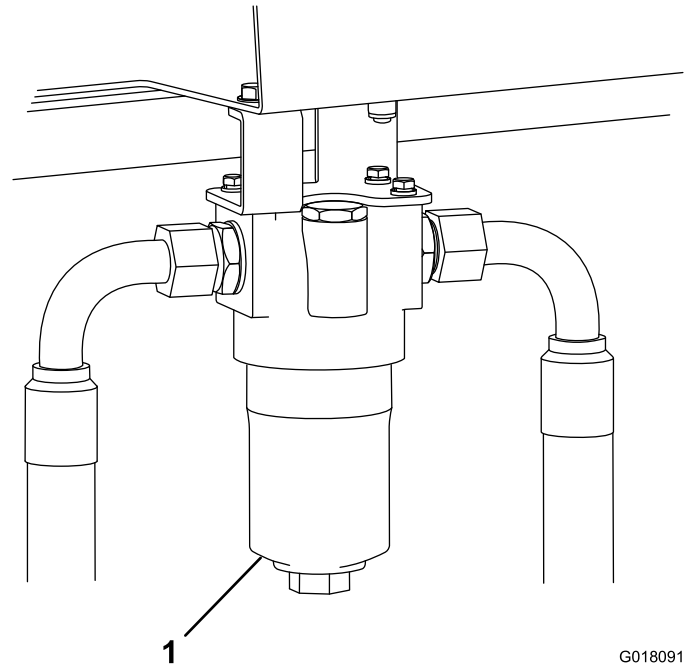

G018091

**Figure 39**

Right side of the machine

1. Transmission-oil filter

1. Unscrew and remove the bottom of the transmission-oil filter housing.
2. Withdraw the filter element and discard it.
3. Install a new filter element (Part No. 924709).
4. Install the housing.

## Changing the Hydraulic-Fluid-Return Filter

Service Interval: After the first 50 hours

Every 500 hours

1. Remove the return filter.
2. Wipe oil onto the new return-filter gasket.
3. Install the new return filter to the machine.

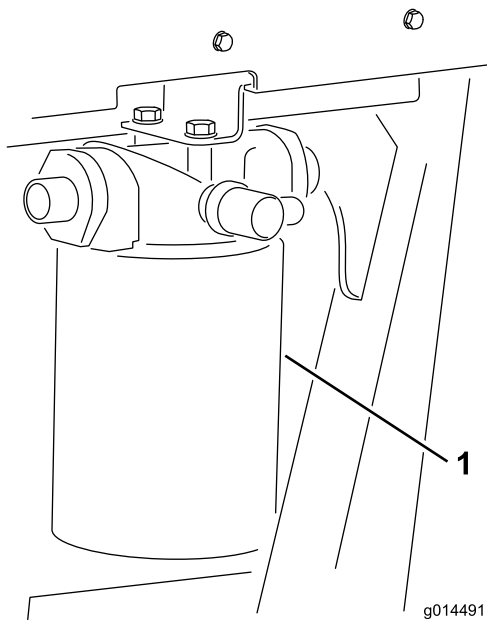

**Figure 40**  
Left side of the machine

1. Hydraulic-fluid-return filter

## Checking the Rear Wheel Alignment

**Service Interval:** Every 500 hours

To prevent excessive tire wear and ensure safe machine operation, align the rear wheels to 3 to 8 mm (0.12 to 0.31 inch).

1. Set the rear wheels in the straight ahead position.
2. Measure and compare the distance between the front sidewalls and the rear sidewalls at the wheel centre height. The distance between the front sidewalls must be set 3 to 8 mm (0.12 to 0.31 inches) less than the distance between the rear sidewalls.

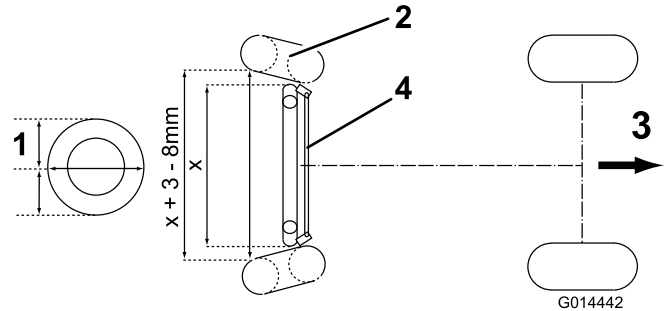

**Figure 41**

- |                        |                                |
|------------------------|--------------------------------|
| 1. Wheel center height | 3. Direction of forward travel |
| 2. Tire                | 4. Track-rod assembly          |

3. To adjust the alignment of the rear wheels, back off the left and right locknuts on the track rod assembly.

**Note:** The left locknut is a left-hand thread

4. Rotate the track rod to achieve the correct distance as described above and tighten the locknuts securely.

# Cooling System Maintenance

## Removing Debris from the Cooling System

**Service Interval:** Before each use or daily

Every 100 hours

Every 2 years

**Note:** To prevent the engine from overheating, the radiator and oil cooler must be kept clean. Normally, check daily and, if necessary, clean any debris off these parts. However, it will be necessary to check and clean more frequently in extremely dusty and dirty conditions.

1. Park the machine on a level surface, stop the engine, set the parking brake and remove the key from the ignition switch.
2. Clean the radiator screen.
3. Thoroughly clean all debris out of the engine area.
4. Release the latch and open the engine cover (Figure 42).

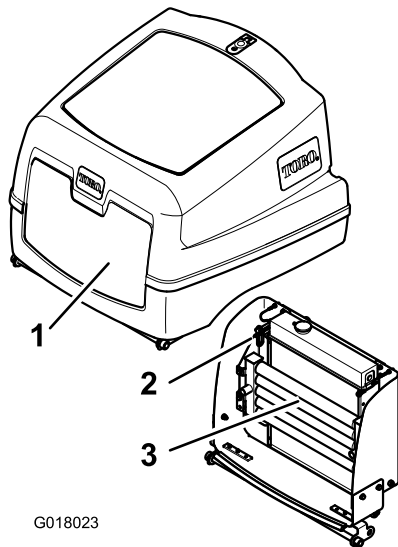

**Figure 42**

1. Engine cover
2. Oil cooler
3. Oil-cooler release clip

5. Clean the screen thoroughly with compressed air.
6. Pivot the latch inward to release the oil cooler (Figure 43).

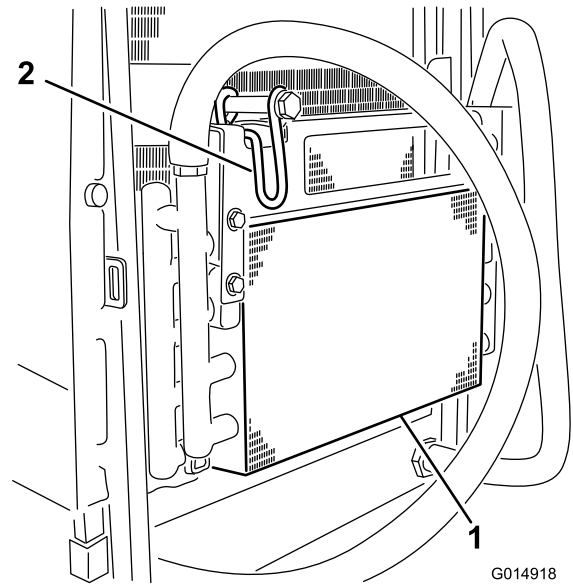

**Figure 43**

1. Oil cooler
2. Oil-cooler latch

7. Working from the fan side of the radiator, blow out debris with low pressure 344 kPa (50 psi) compressed air (do not use water).

**Note:** Repeat this step from the front of the radiator and again from the fan side.

8. Thoroughly clean both sides of the oil cooler. After the radiator and oil coolers are thoroughly cleaned, clean out any debris that may have collected on other parts of the machine (Figure 44) with compressed air.

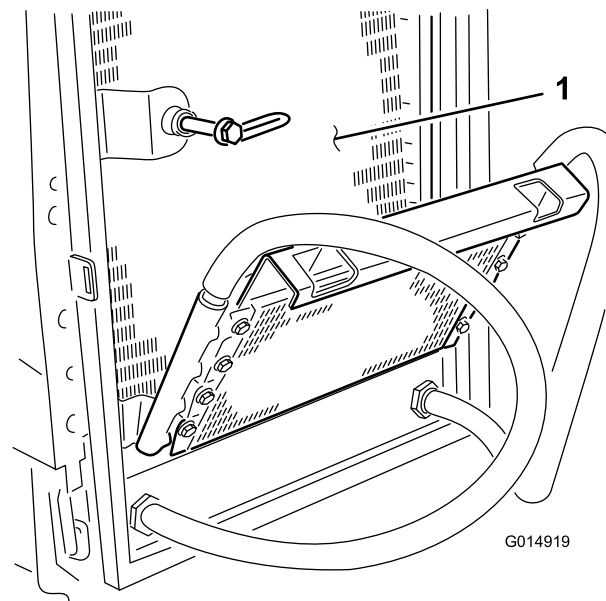

**Figure 44**

1. Radiator

9. Pivot the oil cooler back into position and secure the latch.
10. Close the engine cover and secure the latch.

# Brake Maintenance

## Towing the Mower

Ensure that the towing vehicle specification is suited to braking the combined vehicle weight and able to remain in complete control at all times. Ensure that you apply the parking brake on the towing vehicle. Chock the mower front wheels to prevent the mower from rolling away.

1. Connect a rigid tow bar between the front towing eye on the mower and a suitable towing vehicle.
2. Identify the right, front disc brake assembly and remove the hex plug (Figure 45).
3. Locate the M12 x 40 set screw stored underneath the operator platform, one in each of the platform support rails.
4. Install a M12 x 40 mm long set screw with washer into the hole in the centre of the motor end plate.
5. Tighten the set screw into the threaded hole in the brake piston until the brake is released (Figure 46).

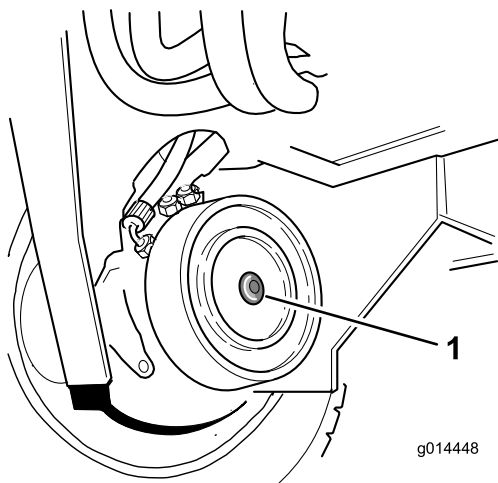

Figure 45

1. Hex plug

6. Identify the left, front disc-brake assembly and repeat the previous procedure (Figure 46).

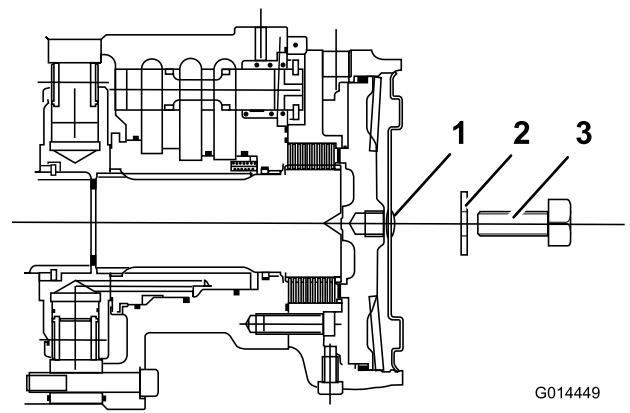

Figure 46

1. Hex plug
2. Washer (M12)
3. Set screw (M12 x 40)

7. Release the hydraulic-braking system by turning the bypass valve, located under the transmission pump, counter-clockwise, a maximum of 3 turns (Figure 47).

**Note:** You must operate the steering manually when the mower is being towed. The steering will feel heavy as there is no hydraulic assistance when the engine is switched off.

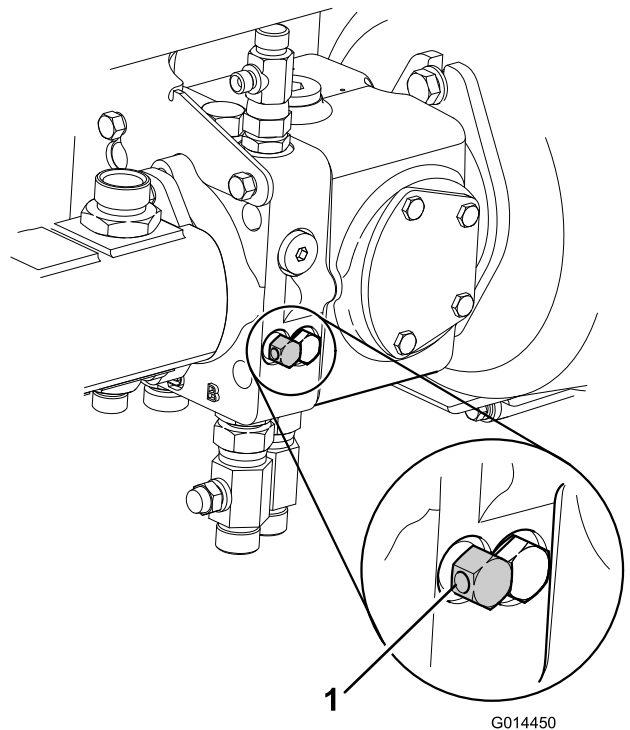

Figure 47

1. Transmission-bypass valves

8. The mower is now in a free-wheel condition and can be towed for a short distance at slow speed.

**Note:** Remove the wheel chocks before towing.

9. After towing the mower, return the mower to its normal working condition by performing the following procedure:
  - A. Chock the front wheels.
  - B. Close the bypass valve on the transmission pump by turning it clockwise.
10. **Engage the front wheel brakes as follows:**

**Note:** Ensure that the M12 x 40 set screws are removed and stored underneath the operator platform.

- A. Identify the right, front wheel brake assembly.
- B. Rotate the set screw counter-clockwise and remove with washer.
- C. Assemble the hex plug into the motor end plate (Figure 48).

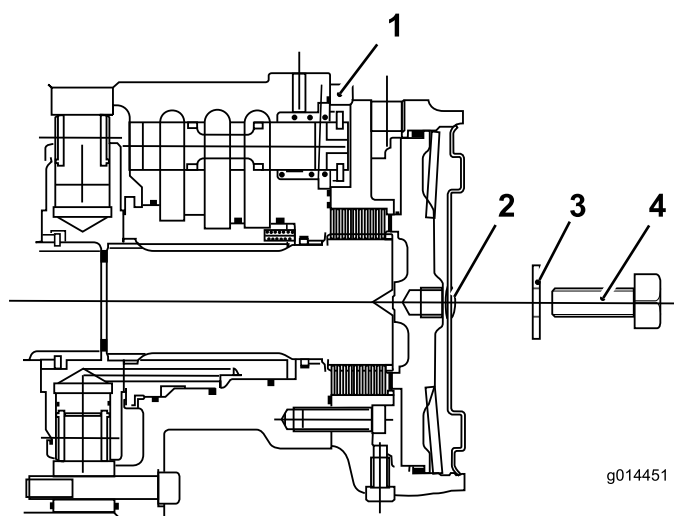

**Figure 48**

- |                      |                         |
|----------------------|-------------------------|
| 1. Front wheel motor | 3. Washer (M12)         |
| 2. Hex plug          | 4. Set screw (M12 x 40) |

- D. Identify the left front wheel-brake assembly and repeat the previous procedure.
- E. Remove the wheel chocks.
- F. Disconnect the tow bar. The mower braking system will now operate in the normal way.

## **⚠ WARNING**

Operating the machine without the brakes functioning properly can cause personal injury or death to you and others and damage to the machine and property. Before using the mower, ensure that the braking system is operating properly. -Check the machine after servicing the brakes initially at a slow speed. -Do not operate the machine if the brakes are damaged or removed.

Before using the mower, ensure that the braking system is operating properly.

- Check the machine after servicing the brakes initially at a slow speed.
- Do not operate the machine if the brakes are damaged or removed.

# Belt Maintenance

Check the condition and tension of the alternator belt after the first day of operation and every 100 operating hours thereafter.

## Tensioning the Alternator Belt

**Service Interval:** After the first 8 hours

Every 100 hours

1. Open the hood.
2. Check the tension of the alternator belt by depressing it (Figure 49) midway between the alternator and the crankshaft pulleys with 10 kg (22 lb) of force.

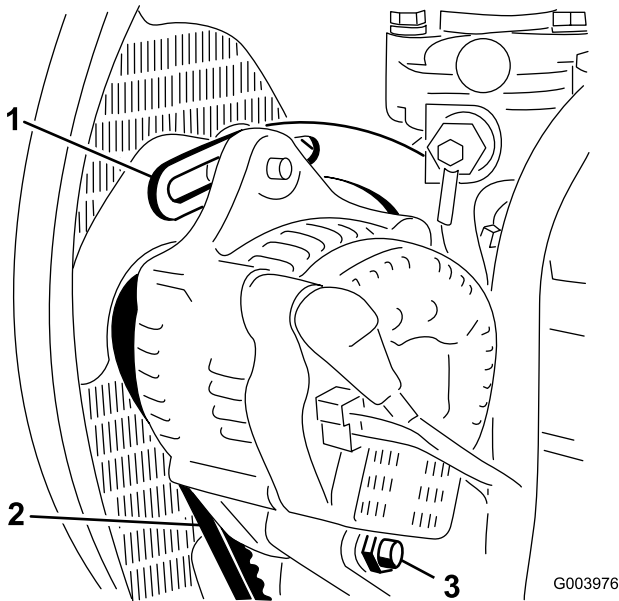

**Figure 49**

1. Brace
2. Alternator belt
3. Pivot bolt

The belt should deflect 11 mm (7/16 inch). If the deflection is incorrect, proceed to step 3. If correct, continue operation.

3. Loosen the bolt securing the brace to the engine (Figure 49), the bolt securing the alternator to the brace, and the pivot bolt.
4. Insert a pry bar between the alternator and the engine and pry out on the alternator.
5. When you achieve the proper tension, tighten the alternator, brace, and pivot bolts to secure the adjustment.

# Controls System Maintenance

## Checking the Forward and Reverse Pedal Action

With the engine switched off, operate the forward and reverse travel pedals through the full range of articulation and ensure that the mechanism returns freely to the NEUTRAL position.

## Operating the Presence Seat Switch

**Service Interval:** Before each use or daily

1. Sit on the operator's seat and start the engine.
2. Lower the cutting unit to the ground.
3. Engage the cutting unit drive switch.
4. Rise from the operator's seat and check that the cutting unit comes to a stop after an initial 0.5- to 1-second delay.

## Using the Cutting Unit Interlock Switch

1. Stop the mower engine.
2. Operate the cutting unit drive switch to the OFF position and turn the ignition key to position I. The cutting unit drive switch indicator light should not illuminate. Refer to (page ).
3. Operate the switch to the on position. The indicator light should illuminate and the engine should not start when you turn the ignition key.

## Using the Parking-Brake Interlock Switch

1. Stop the engine.
2. Engage the parking brake.
3. Turn the ignition key to position the ON position (I).

**Note:** The parking brake indicator light should illuminate.

4. Disengage the parking brake.

**Note:** The indicator light should go out and the engine should not start when the ignition key is turned.

5. Set the parking brake, sit on the operator's seat, and start the engine.
6. Release the parking brake.
7. Rise from the operator's seat and check that the engine stops.

# Inspecting the Transmission Control Cable and Operating Mechanism

**Service Interval:** Every 250 hours

Check the condition and security of the cable and operating mechanism at the speed control pedals and transmission pump ends.

- Remove any build up of dirt, grit, and other deposits.
- Ensure that the ball joints are securely anchored and check that mounting brackets and cable anchors are tight and free from cracks.
- Inspect end fittings for wear, corrosion, broken springs, and replace if necessary.
- Ensure that the rubber seals are correctly located and are in good condition.
- Ensure that the articulating sleeves supporting the inner cable are in good condition and firmly attached to the outer cable assembly at the crimped connections. If there are any signs of cracking or detachment install a new cable immediately.
- Check that sleeves, rods, and inner cable are free from bends, kinks, or other damage. If they are not, install a new cable immediately.
- With the engine switched off, operate the pedal controls through the entire range and ensure that the mechanism moves smoothly and freely to the neutral position without sticking or hanging up.

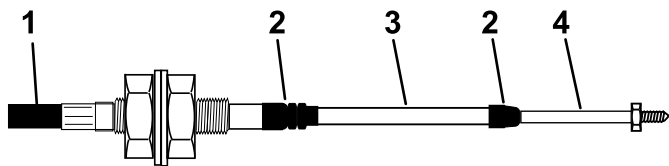

g014571

**Figure 50**

- |                |            |
|----------------|------------|
| 1. Outer cover | 3. Sleeve  |
| 2. Rubber seal | 4. Rod end |

# Transmission Neutral Interlock Switch

1. Stop the mower engine.
2. Remove your foot from the forward/reverse travel pedals.
3. Turn the ignition key to the ON position (I) and the transmission neutral indicator light should illuminate.
4. Apply light pressure to the travel pedals in a forward and reverse direction to check that the indicator light turns off.

**Note:** Take extreme care to ensure that the area around the mower is clear before checking that the engine does not start under this condition.

# Hydraulic System Maintenance

## ⚠ WARNING

Hydraulic fluid escaping under pressure can penetrate skin and cause injury.

- Make sure that all hydraulic-fluid hoses and lines are in good condition and that all hydraulic connections and fittings are tight before applying pressure to the hydraulic system.
- Keep your body and hands away from pin hole leaks or nozzles that eject high-pressure hydraulic fluid.
- Use cardboard or paper to find hydraulic leaks.
- Safely relieve all pressure in the hydraulic system before performing any work on the hydraulic system.
- Get immediate medical help if fluid is injected into skin.

## Service the Hydraulic System

**Service Interval:** Every 500 hours

**Note:** Keep water away from electrical components. Use a dry cloth or brush to clean such areas.

This procedure is best carried out when the hydraulic fluid is warm (not hot). Lower the cutting unit to the ground and drain the hydraulic system.

1. Remove the oil tank filler flange to gain access to the suction strainer.
2. Unscrew and remove the strainer and clean with paraffin or petrol before installing.
3. Install the return-line-oil-filter element.
4. Install the transmission-oil-filter element.
5. Refill the hydraulic tank with fresh clean hydraulic fluid of the recommended grade, refer to (page).
6. Run the machine and operate all hydraulic systems until the hydraulic fluid is warm.
7. Check the oil level and top it up as necessary to the upper mark on the sight-level gauge.

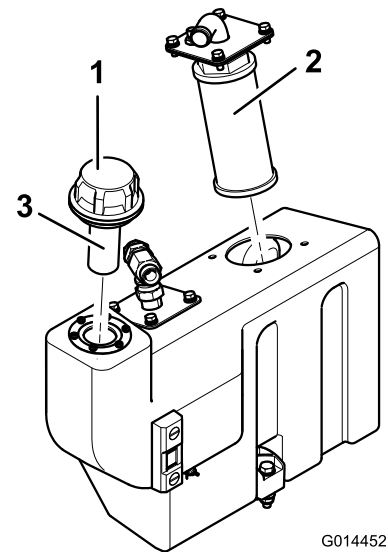
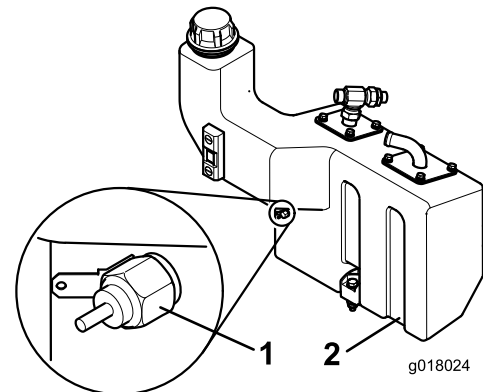

**Figure 51**

1. Tank-filler cap
2. Suction strainer
3. Filler strainer

## Checking the Hydraulic-Fluid Overheat Warning System

**Service Interval:** Every 500 hours



**Figure 52**

1. Temperature switch
2. Hydraulic-oil tank

1. Turn the ignition key to the ON position (I).
2. Disconnect the red/yellow wire terminal from the hydraulic tank temperature switch.
3. Touch the metal terminal of the wire onto a suitable earth point, ensuring that the metal surfaces make good contact.

The horn will sound and the hydraulic-fluid-temperature-warning light will illuminate to confirm correct operation. If necessary, make repairs before operating the mower.

## Checking the Hydraulic Lines and Hoses

Daily, check hydraulic lines and hoses for leaks, kinked lines, loose mounting supports, wear, loose fittings, weather deterioration, and chemical deterioration. Make all necessary repairs before operating the machine.

## Miscellaneous Maintenance

### Waste Disposal

Engine oil, batteries, hydraulic fluid, and engine coolant are pollutants to the environment. Dispose of these according to your local regulations.

When disposing of hazardous waste products, take them to an authorized disposal site. Waste products must not be allowed to contaminate surface water, drains or sewage systems.

#### **⚠ CAUTION**

Dispose of hazardous substances correctly.

- Do not dispose of batteries with a separate collection mark into general waste.
- When disposing of hazardous waste products, take them to an authorized disposal site.

# Storage

## Preparing the Traction Unit

1. Thoroughly clean the traction unit, cutting unit, and engine.
2. Check the tire pressure.
3. Check all fasteners for looseness and tighten them as necessary.
4. Grease all grease fittings and pivot points. Wipe up any excess lubricant.
5. Lightly sand and use touch-up paint on painted areas that are scratched, chipped, or rusted.
6. Service the battery and cables as follows:
  - A. Remove the battery terminals from the battery posts.
  - B. Clean the battery, terminals, and posts with a wire brush and baking soda solution.
  - C. Coat the cable terminals and battery posts with Grafo 112X skin-over grease (Toro Part No. 505-47) or petroleum jelly to prevent corrosion.
  - D. Slowly recharge the battery every 60 days for 24 hours to prevent lead sulfation of the battery.

## Preparing the Engine

1. Drain the engine oil from the oil pan and replace the drain plug.
2. Remove and discard the oil filter. Install a new oil filter.
3. Refill the oil pan with designated quantity of motor oil.
4. Start the engine and run it at idle speed for approximately 2 minutes.
5. Stop the engine.
6. Thoroughly drain all fuel from the fuel tank, lines, and the fuel filter/water separator assembly.
7. Flush the fuel tank with fresh, clean diesel fuel.
8. Secure all fuel system fittings.
9. Thoroughly clean and service the air cleaner assembly.
10. Seal the air cleaner inlet and the exhaust outlet with weatherproof tape.
11. Check the antifreeze protection and add as needed for expected minimum temperature in your area.

# Troubleshooting

Problem	Possible Cause	Corrective Action
The engine does not start with the ignition key.	<ol style="list-style-type: none"> <li>1. The transmission neutral-interlock switch is not energized.</li> <li>2. The parking-brake interlock switch is not energized.</li> <li>3. The cutting-unit drive interlock switch is not energized.</li> <li>4. There is a faulty electrical connection.</li> </ol>	<ol style="list-style-type: none"> <li>1. Remove your foot from the forward/reverse pedals or check the setting of the transmission neutral-interlock switch.</li> <li>2. Operate the parking brake lever to the ON position.</li> <li>3. Check the setting of parking-brake interlock switch.</li> <li>4. Trace and correct the fault.</li> </ol>
The battery is flat.	<ol style="list-style-type: none"> <li>1. The terminal connection is loose or corroded.</li> <li>2. The alternator belt is a loose or damaged.</li> <li>3. The battery is not charged.</li> <li>4. There is an electrical circuit short.</li> </ol>	<ol style="list-style-type: none"> <li>1. Clean and tighten the terminal connections. Charge the battery.</li> <li>2. Adjust the tension or replace the drive belt.</li> <li>3. Charge the battery or check and replace the battery.</li> <li>4. Trace the short in the circuit and fix it.</li> </ol>
The hydraulic system is overheating.	<ol style="list-style-type: none"> <li>1. The radiator is full of debris.</li> <li>2. The oil-cooler fins are plugged.</li> <li>3. The engine-radiator matrix is plugged.</li> <li>4. The relief-valve setting is low.</li> <li>5. The hydraulic fluid is low.</li> <li>6. The brakes are engaged.</li> <li>7. The fan or fan drive is damaged.</li> </ol>	<ol style="list-style-type: none"> <li>1. Clean the screen.</li> <li>2. Clean the fins.</li> <li>3. Clean the matrix.</li> <li>4. Contact an Authorized Service Dealer.</li> <li>5. Fill the reservoir to the correct level.</li> <li>6. Disengage the brakes.</li> <li>7. Check the fan operation and service the fan as needed.</li> </ol>
The brakes operate incorrectly.	<ol style="list-style-type: none"> <li>1. The wheel-motor brake assembly is faulty.</li> <li>2. The brake discs are worn.</li> </ol>	<ol style="list-style-type: none"> <li>1. Contact an Authorized Service Dealer.</li> <li>2. Contact an Authorized Service Dealer.</li> </ol>
The steering does not operate correctly.	<ol style="list-style-type: none"> <li>1. The steering valve is damaged.</li> <li>2. The hydraulic cylinder is damaged.</li> <li>3. The steering hose is damaged.</li> </ol>	<ol style="list-style-type: none"> <li>1. Service or replace the steering valve.</li> <li>2. Service or replace the hydraulic cylinder.</li> <li>3. Replace the damaged hose.</li> </ol>
The machine does not move forward or reverse.	<ol style="list-style-type: none"> <li>1. The parking brake is engaged.</li> <li>2. The hydraulic-fluid level is low.</li> <li>3. Incorrect hydraulic fluid was used.</li> <li>4. The drive-pedal linkage is damaged.</li> <li>5. The transmission pump is damaged.</li> <li>6. The transmission-relief valve is open.</li> <li>7. The drive coupling is broken.</li> <li>8. The transmission filter is blocked.</li> </ol>	<ol style="list-style-type: none"> <li>1. Release the parking brake.</li> <li>2. Fill the reservoir to the correct level.</li> <li>3. Drain the reservoir and refill with the correct oil.</li> <li>4. Check the linkage and replace damaged parts.</li> <li>5. Have the transmission pump overhauled by your authorized dealer.</li> <li>6. Close the relief valve.</li> <li>7. Replace the drive coupling.</li> <li>8. Replace the transmission filter.</li> </ol>
The machine creeps forward or backward in neutral.	<ol style="list-style-type: none"> <li>1. The transmission-neutral adjustment is incorrectly set.</li> </ol>	<ol style="list-style-type: none"> <li>1. Adjust the transmission-neutral linkage setting.</li> </ol>

<b>Problem</b>	<b>Possible Cause</b>	<b>Corrective Action</b>
There is excessive noise in the hydraulic system.	<ol style="list-style-type: none"> <li>1. There is a faulty pump.</li> <li>2. There is a faulty motor.</li> <li>3. There is air leaking into the system.</li> <li>4. The suction strainer is blocked or damaged.</li> <li>5. There is excessive oil viscosity due to cold conditions.</li> <li>6. The relief-valve setting is low.</li> <li>7. The hydraulic-fluid level is low.</li> </ol>	<ol style="list-style-type: none"> <li>1. Identify the noisy pump and service or replace.</li> <li>2. Identify the noisy motor and service or replace.</li> <li>3. Tighten or replace hydraulic fittings, particularly in suction lines.</li> <li>4. Clean and replace the suction strainer.</li> <li>5. Allow the system to warm up.</li> <li>6. Have the relief valve cleaned and pressure checked. Contact an Authorized Service Dealer.</li> <li>7. Fill the hydraulic-fluid reservoir to the correct level.</li> </ol>
After initial operation, the machine loses power.	<ol style="list-style-type: none"> <li>1. There is a worn pump or motor.</li> <li>2. The hydraulic-oil level is low.</li> <li>3. The hydraulic-oil viscosity is incorrect.</li> <li>4. The oil-filter element is blocked.</li> <li>5. The pressure relief valve does not function.</li> <li>6. There is overheating.</li> <li>7. There are leaks in the suction hose.</li> </ol>	<ol style="list-style-type: none"> <li>1. Replace as the pump or motor.</li> <li>2. Fill the hydraulic-fluid reservoir to the correct level.</li> <li>3. Replace the oil in hydraulic tank with correct viscosity of oil.</li> <li>4. Change the filter element.</li> <li>5. Have the relief valve cleaned and pressure checked. Consult your authorized dealer.</li> <li>6. Reduce the work rate, i.e., increase the height of cut or reduce your forward speed.</li> <li>7. Check and tighten fittings. Replace hose if necessary.</li> </ol>
Cutting unit fails to lift out of work.	<ol style="list-style-type: none"> <li>1. Lift cylinder seal failure.</li> <li>2. Pressure-relief valve is jammed open or wrongly set.</li> <li>3. The control valve is not functioning.</li> <li>4. There is a mechanical blockage.</li> </ol>	<ol style="list-style-type: none"> <li>1. Replace seals.</li> <li>2. Have relief valve cleaned and pressure checked. Consult your authorized dealer.</li> <li>3. Overhaul the control valve.</li> <li>4. Remove the blockage.</li> </ol>
Cutting unit does not follow ground contours.	<ol style="list-style-type: none"> <li>1. There is tightness in the pivots.</li> <li>2. Mower operated in the Hold position.</li> <li>3. The weight transfer set too high.</li> </ol>	<ol style="list-style-type: none"> <li>1. Release and grease the pivots as needed.</li> <li>2. Move position-control switch to 'Down / Float' position.</li> <li>3. Reduce the weight transfer.</li> </ol>

Problem	Possible Cause	Corrective Action
A cutting unit fails to start up.	<ol style="list-style-type: none"> <li>1. The seat-sensor switch is not functioning.</li> <li>2. The hydraulic-fluid level is low.</li> <li>3. The drive shaft is sheared.</li> <li>4. The pressure-relief valve is jammed open or wrongly set.</li> <li>5. The cutting-unit blade(s) is jammed.</li> <li>6. The cutting-unit control valve is in the Off position caused by a non-functioning control valve.</li> <li>7. The cutting-unit control valve is in the Off position caused by an electrical fault.</li> </ol>	<ol style="list-style-type: none"> <li>1. Check the mechanical and electrical operation of the switch.</li> <li>2. Fill the hydraulic-fluid reservoir to the correct level.</li> <li>3. Check the motor and drive shafts and replace them if necessary.</li> <li>4. Have the relief valve cleaned and pressure checked. Consult your authorized dealer.</li> <li>5. Clear the jam as needed.</li> <li>6. Overhaul the control valve.</li> <li>7. Have the electrical system checked.</li> </ol>
The blades are rotating in wrong direction.	<ol style="list-style-type: none"> <li>1. The hoses are incorrectly connected</li> </ol>	<ol style="list-style-type: none"> <li>1. Check the hydraulic circuit and reconnect as needed.</li> </ol>

## International Distributor List

<b>Distributor:</b>	<b>Country:</b>	<b>Phone Number:</b>	<b>Distributor:</b>	<b>Country:</b>	<b>Phone Number:</b>
Agrolanc Kft	Hungary	36 27 539 640	Maquiver S.A.	Colombia	57 1 236 4079
Asian American Industrial (AAI)	Hong Kong	852 2497 7804	Maruyama Mfg. Co. Inc.	Japan	81 3 3252 2285
B-Ray Corporation	Korea	82 32 551 2076	Mountfield a.s.	Czech Republic	420 255 704 220
Brisa Goods LLC	Mexico	1 210 495 2417	Mountfield a.s.	Slovakia	420 255 704 220
Casco Sales Company	Puerto Rico	787 788 8383	Munditol S.A.	Argentina	54 11 4 821 9999
Ceres S.A.	Costa Rica	506 239 1138	Norma Garden	Russia	7 495 411 61 20
CSSC Turf Equipment (pvt) Ltd.	Sri Lanka	94 11 2746100	Oslinger Turf Equipment SA	Ecuador	593 4 239 6970
Cyril Johnston & Co.	Northern Ireland	44 2890 813 121	Oy Hako Ground and Garden Ab	Finland	358 987 00733
Cyril Johnston & Co.	Republic of Ireland	44 2890 813 121	Parkland Products Ltd.	New Zealand	64 3 34 93760
Fat Dragon	China	886 10 80841322	Perfetto	Poland	48 61 8 208 416
Femco S.A.	Guatemala	502 442 3277	Pratoverde SRL.	Italy	39 049 9128 128
FIVEMANS New-Tech Co., Ltd	China	86-10-6381 6136	Prochaska & Cie	Austria	43 1 278 5100
ForGarder OU	Estonia	372 384 6060	RT Cohen 2004 Ltd.	Israel	972 986 17979
G.Y.K. Company Ltd.	Japan	81 726 325 861	Riversa	Spain	34 9 52 83 7500
Geomechaniki of Athens	Greece	30 10 935 0054	Lely Turfcare	Denmark	45 66 109 200
Golf international Turizm	Turkey	90 216 336 5993	Lely (U.K.) Limited	United Kingdom	44 1480 226 800
Hako Ground and Garden	Sweden	46 35 10 0000	Solvart S.A.S.	France	33 1 30 81 77 00
Hako Ground and Garden	Norway	47 22 90 7760	Spypros Stavrinides Limited	Cyprus	357 22 434131
Hayter Limited (U.K.)	United Kingdom	44 1279 723 444	Surge Systems India Limited	India	91 1 292299901
Hydroturf Int. Co Dubai	United Arab Emirates	97 14 347 9479	T-Markt Logistics Ltd.	Hungary	36 26 525 500
Hydroturf Egypt LLC	Egypt	202 519 4308	Toro Australia	Australia	61 3 9580 7355
Irrimac	Portugal	351 21 238 8260	Toro Europe NV	Belgium	32 14 562 960
Irrigation Products Int'l Pvt Ltd.	India	0091 44 2449 4387	Valtech	Morocco	212 5 3766 3636
Jean Heybroek b.v.	Netherlands	31 30 639 4611	Victus Emak	Poland	48 61 823 8369

### European Privacy Notice

#### The Information Toro Collects

Toro Warranty Company (Toro) respects your privacy. In order to process your warranty claim and contact you in the event of a product recall, we ask you to share certain personal information with us, either directly or through your local Toro company or dealer.

The Toro warranty system is hosted on servers located within the United States where privacy law may not provide the same protection as applies in your country.

BY SHARING YOUR PERSONAL INFORMATION WITH US, YOU ARE CONSENTING TO THE PROCESSING OF YOUR PERSONAL INFORMATION AS DESCRIBED IN THIS PRIVACY NOTICE.

#### The Way Toro Uses Information

Toro may use your personal information to process warranty claims, to contact you in the event of a product recall and for any other purpose which we tell you about. Toro may share your information with Toro's affiliates, dealers or other business partners in connection with any of these activities. We will not sell your personal information to any other company. We reserve the right to disclose personal information in order to comply with applicable laws and with requests by the appropriate authorities, to operate our systems properly or for our own protection or that of other users.

#### Retention of your Personal Information

We will keep your personal information as long as we need it for the purposes for which it was originally collected or for other legitimate purposes (such as regulatory compliance), or as required by applicable law.

#### Toro's Commitment to Security of Your Personal Information

We take reasonable precautions in order to protect the security of your personal information. We also take steps to maintain the accuracy and current status of personal information.

#### Access and Correction of your Personal Information

If you would like to review or correct your personal information, please contact us by email at [legal@toro.com](mailto:legal@toro.com).

### Australian Consumer Law

Australian customers will find details relating to the Australian Consumer Law either inside the box or at your local Toro Dealer.



# Toro General Commercial Product Warranty

## A Two-Year Limited Warranty

### Conditions and Products Covered

The Toro Company and its affiliate, Toro Warranty Company, pursuant to an agreement between them, jointly warrant your Toro Commercial product ("Product") to be free from defects in materials or workmanship for two years or 1500 operational hours\*, whichever occurs first. This warranty is applicable to all products with the exception of Aerators (refer to separate warranty statements for these products). Where a warrantable condition exists, we will repair the Product at no cost to you including diagnostics, labor, parts, and transportation. This warranty begins on the date the Product is delivered to the original retail purchaser.

\* Product equipped with an hour meter.

### Instructions for Obtaining Warranty Service

You are responsible for notifying the Commercial Products Distributor or Authorized Commercial Products Dealer from whom you purchased the Product as soon as you believe a warrantable condition exists. If you need help locating a Commercial Products Distributor or Authorized Dealer, or if you have questions regarding your warranty rights or responsibilities, you may contact us at:

Toro Commercial Products Service Department  
Toro Warranty Company  
8111 Lyndale Avenue South  
Bloomington, MN 55420-1196  
952-888-8801 or 800-952-2740  
E-mail: commercial.warranty@toro.com

### Owner Responsibilities

As the Product owner, you are responsible for required maintenance and adjustments stated in your *Operator's Manual*. Failure to perform required maintenance and adjustments can be grounds for disallowing a warranty claim.

### Items and Conditions Not Covered

Not all product failures or malfunctions that occur during the warranty period are defects in materials or workmanship. This warranty does not cover the following:

- Product failures which result from the use of non-Toro replacement parts, or from installation and use of add-on, or modified non-Toro branded accessories and products. A separate warranty may be provided by the manufacturer of these items.
- Product failures which result from failure to perform recommended maintenance and/or adjustments. Failure to properly maintain your Toro product per the Recommended Maintenance listed in the *Operator's Manual* can result in claims for warranty being denied.
- Product failures which result from operating the Product in an abusive, negligent, or reckless manner.
- Parts subject to consumption through use unless found to be defective. Examples of parts which are consumed, or used up, during normal Product operation include, but are not limited to, brake pads and linings, clutch linings, blades, reels, rollers and bearings (sealed or greasable), bed knives, spark plugs, castor wheels and bearings, tires, filters, belts, and certain sprayer components such as diaphragms, nozzles, and check valves, etc.
- Failures caused by outside influence. Conditions considered to be outside influence include, but are not limited to, weather, storage practices, contamination, use of unapproved fuels, coolants, lubricants, additives, fertilizers, water, or chemicals, etc.
- Failure or performance issues due to the use of fuels (e.g. gasoline, diesel, or biodiesel) that do not conform to their respective industry standards.

### Countries Other than the United States or Canada

Customers who have purchased Toro products exported from the United States or Canada should contact their Toro Distributor (Dealer) to obtain guarantee policies for your country, province, or state. If for any reason you are dissatisfied with your Distributor's service or have difficulty obtaining guarantee information, contact the Toro importer.

- Normal noise, vibration, wear and tear, and deterioration.
- Normal "wear and tear" includes, but is not limited to, damage to seats due to wear or abrasion, worn painted surfaces, scratched decals or windows, etc.

### Parts

Parts scheduled for replacement as required maintenance are warranted for the period of time up to the scheduled replacement time for that part. Parts replaced under this warranty are covered for the duration of the original product warranty and become the property of Toro. Toro will make the final decision whether to repair any existing part or assembly or replace it. Toro may use remanufactured parts for warranty repairs.

### Deep Cycle and Lithium-Ion Battery Warranty:

Deep cycle and Lithium-Ion batteries have a specified total number of kilowatt-hours they can deliver during their lifetime. Operating, recharging, and maintenance techniques can extend or reduce total battery life. As the batteries in this product are consumed, the amount of useful work between charging intervals will slowly decrease until the battery is completely worn out. Replacement of worn out batteries, due to normal consumption, is the responsibility of the product owner. Battery replacement may be required during the normal product warranty period at owner's expense. Note: (Lithium-Ion battery only): A Lithium-Ion battery has a part only prorated warranty beginning year 3 through year 5 based on the time in service and kilowatt hours used. Refer to the *Operator's Manual* for additional information.

### Maintenance is at Owner's Expense

Engine tune-up, lubrication, cleaning and polishing, replacement of filters, coolant, and completing recommended maintenance are some of the normal services Toro products require that are at the owner's expense.

### General Conditions

Repair by an Authorized Toro Distributor or Dealer is your sole remedy under this warranty.

**Neither The Toro Company nor Toro Warranty Company is liable for indirect, incidental or consequential damages in connection with the use of the Toro Products covered by this warranty, including any cost or expense of providing substitute equipment or service during reasonable periods of malfunction or non-use pending completion of repairs under this warranty. Except for the Emissions warranty referenced below, if applicable, there is no other express warranty. All implied warranties of merchantability and fitness for use are limited to the duration of this express warranty.**

Some states do not allow exclusions of incidental or consequential damages, or limitations on how long an implied warranty lasts, so the above exclusions and limitations may not apply to you. This warranty gives you specific legal rights, and you may also have other rights which vary from state to state.

### Note regarding engine warranty:

The Emissions Control System on your Product may be covered by a separate warranty meeting requirements established by the U.S. Environmental Protection Agency (EPA) and/or the California Air Resources Board (CARB). The hour limitations set forth above do not apply to the Emissions Control System Warranty. Refer to the Engine Emission Control Warranty Statement supplied with your product or contained in the engine manufacturer's documentation for details