



Count on it.

Parts Catalog

55cm Recycler®

Lawn Mower

Model No. 20960—Serial No. 316000001 and Up



Ordering Replacement Parts

To order replacement parts, please supply the part number, the quantity, and the description of each part desired.

Understanding Reference Numbers

Each identified part in an illustration has a reference number. The reference number for a part also appears in the parts list, along with other information about the part.

This catalog uses two special reference number formats, one to indicate parts in a service assembly and another to indicate the quantity of a given part in an illustration.

Service Assembly Reference Numbers

Parts in service assemblies have reference numbers in the form a:b. The a represents the reference number of the entire service assembly and the b represents a sequential number unique to each part within the service assembly.

For example, a wheel assembly might be identified by reference number 6, the tire by 6:1, the valve by 6:2, and the wheel by 6:3. When you order the assembly identified by reference number 6, you receive all parts identified by reference numbers 6:1, 6:2, and 6:3. However, you may also order any part individually. Reference numbers of this type appear in illustration and in parts lists.

Reference Numbers Indicating Quantity

In an illustration, if a reference number indicates more than one part, the reference number has the form nX y. The n represents the quantity of the part, the X is the multiplication symbol, and the y represents the reference number.

For example, in an illustration, the reference number 2X 37 means that two of the parts identified by reference number 37 are indicated.

List of Abbreviations

AR: as required

ASM: assembly

BBC: blade brake control

BHTF: button head thread forming

CARR: carriage

CCW: counter clockwise

CW: clockwise

DEG: degrees

DPA: Dual Point Adjustment

ECM: electronic control module

EXT: external

FH: flat head

GA: gauge

HD: heavy-duty

HF: hex flange

HH: hex head

HHF: hex head flange

HHFTF: hex head flange thread forming

HJ: hex jam

HLH: hex lag head

HOC: height-of-cut

HP: high pressure

HSBH: hex socket button head

HSFH: hex socket flat head

HSH: hex socket head

HWH: hex washer head

HWHTF: hex washer head thread forming

HYD: hydraulic

LH: left hand

LP: low pressure

LPG: Liquefied Petroleum Gas

NI: nylon insert

NPTF: national pipe thread fine

PFH: phillips flat head

PPH: phillips pan head

PPHTF: phillips pan head thread forming

PRH: phillips round head

PTH: phillips truss head

PTO: power-take-off

RH: right hand

ROPS: roll-over protection system

RRB: rear roller brush

SFH: slotted fillister head

SHH: slotted hex head

SHWH: slotted hex washer head

SPH: slotted pan head

SQH: square head

SRH: slotted round head

STD: standard

TAP: self tapping

TTH: torx truss head

Contents

Housing and Rear Deflector Assembly	4
Rear Bag Assembly	6
Engine and Blade Assembly	8
Transmission and Front Wheel Drive Assembly	10
Rear Wheel and Height-of-Cut Assembly	12
Handle Assembly	14
Attachments and Accessories	16

Housing and Rear Deflector Assembly

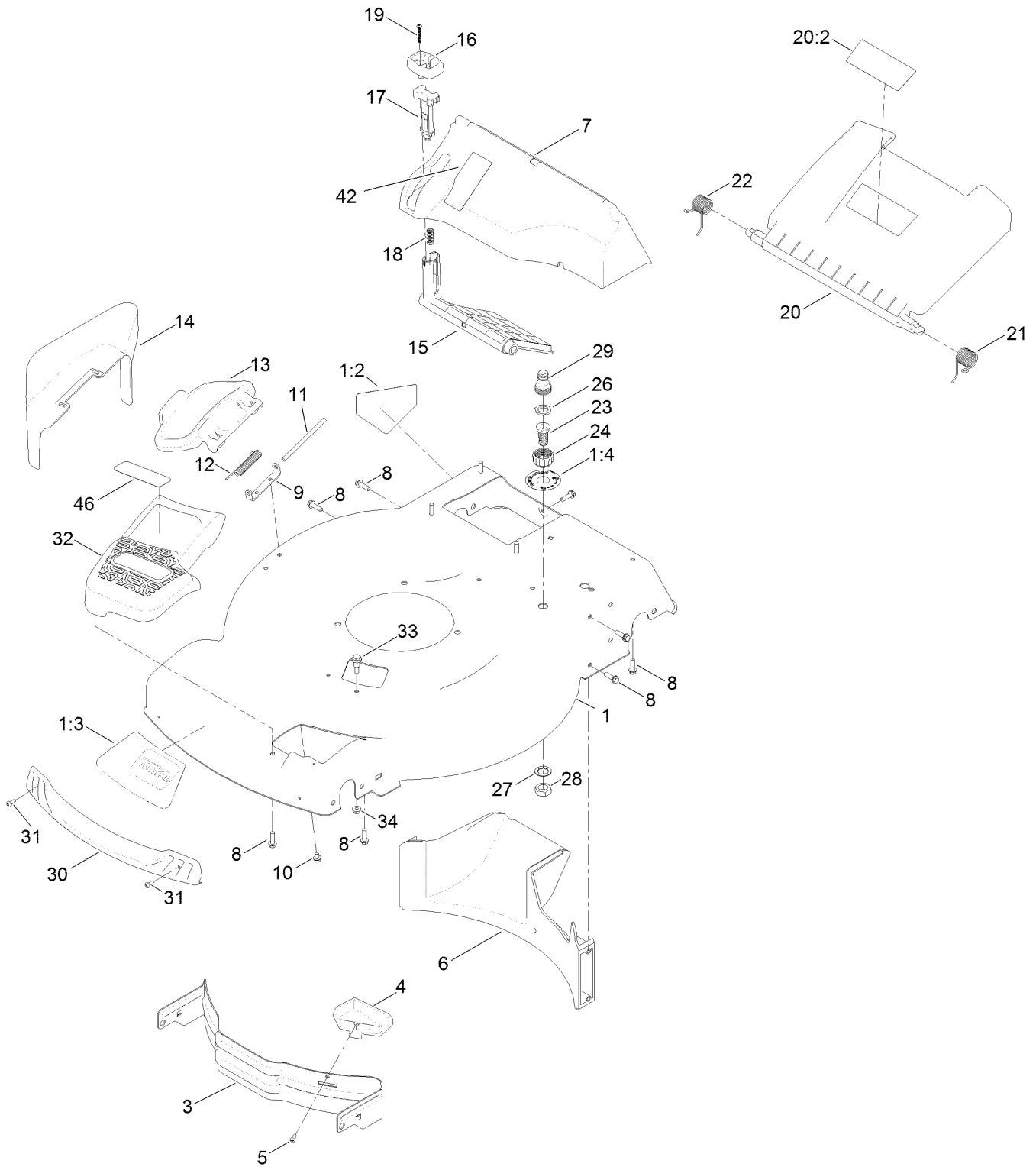

Housing and Rear Deflector Assembly (continued)

<i>Ref.</i>	<i>Part Number</i>	<i>Qty.</i>	<i>Description</i>	<i>Ref.</i>	<i>Part Number</i>	<i>Qty.</i>	<i>Description</i>
1	131-9671	1	Housing ASM	19	32104-120	2	Screw-PPH
1:2	112-8760	1	Decal-Danger	20	121-5776	1	Rear Door ASM
1:3	120-3323	1	Decal-Deck	20:2	131-4514	1	Decal-Warning
1:4	112-8867	1	Decal-Port, Washout	21	115-2859	1	Spring-Torsion
3	115-4667-01	1	Baffle-Front	22	114-7924	1	Spring-Torsion
4	115-4672	1	Kicker-Front	23	112-6400	1	Port-Washout
5	32144-111	1	Screw-PPH	24	112-6401	1	Coupling-Hose, Washout Port
6	114-7961	1	Baffle-Rear	26	112-6438	1	Washer-Seal, Washout Port
7	132-4501	1	Chute-Recycle	27	3254-5	1	Washer-Tooth, Internal
8	46-8091	11	Screw-HWH	28	3218-6	1	Nut-Jam
9	112-6416	1	Bracket-Cover	29	112-6437	1	Adapter-Connect, Quick
10	99-8445	2	Screw-HWH	30	114-7987	1	Bumper
11	99-5291	1	Rod-Cover	31	105-6849	2	Screw-Thread Forming
12	99-5293	1	Spring-Torsion	32	130-6708	1	Cover-Belt, Front
13	115-8449	1	Deflector-Side	33	104-0858	1	Bolt-Shoulder
14	115-8447	1	Chute-Discharge, Side	34	3296-16	1	Nut-Lock, NI
15	114-7960	1	Deflector-Recycle	42	125-5026	1	Decal-Bag On Demand
16	114-7958	1	Knob-Recycle	46	131-4527	1	Decal-Cover
17	114-7959	1	Latch-Recycle				
18	117-1031	1	Spring-Compression				

Rear Bag Assembly

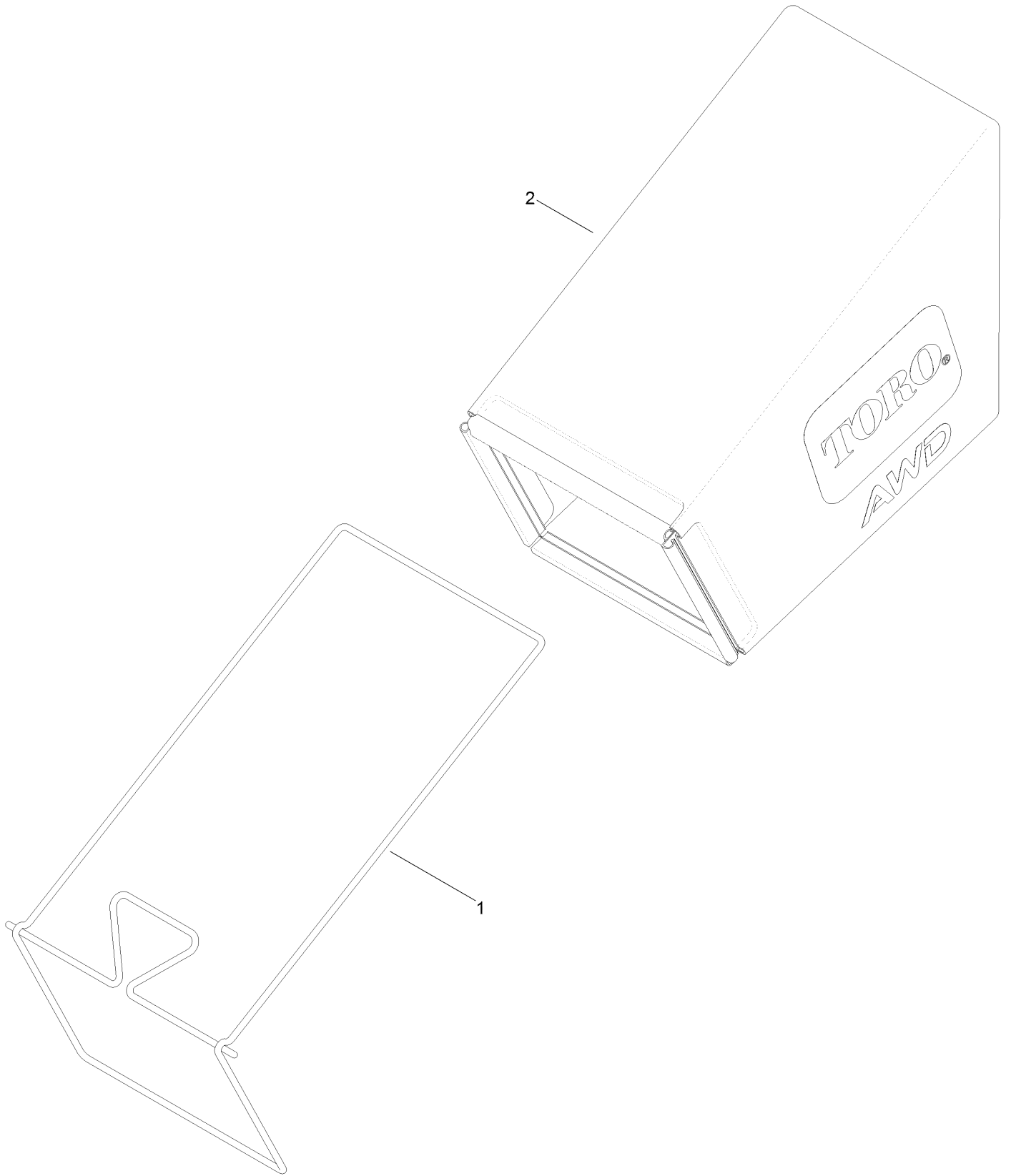

Rear Bag Assembly (continued)

<i>Ref.</i>	<i>Part Number</i>	<i>Qty.</i>	<i>Description</i>
1	132-4503-03	1	Frame-Bag
2	131-0893	1	Grass Bag ASM

Engine and Blade Assembly

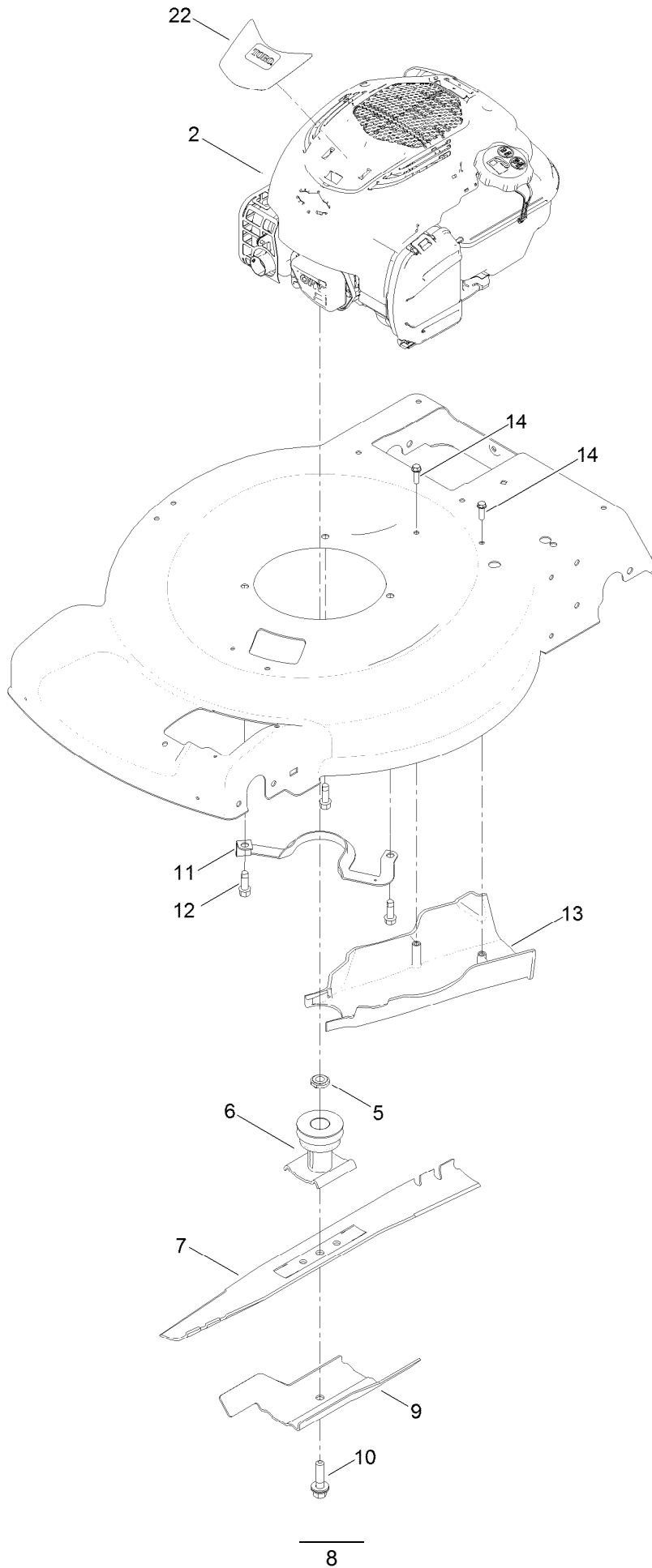

Engine and Blade Assembly (continued)

<i>Ref.</i>	<i>Part Number</i>	<i>Qty.</i>	<i>Description</i>	<i>Ref.</i>	<i>Part Number</i>	<i>Qty.</i>	<i>Description</i>
2		1	Engine-Briggs 104M020043F1 ●■	10	125-2466	1	Bolt-Blade
5	106-3999	1	Spacer-Driver	11	130-6702-03	1	Guide-Belt
6	130-6705	1	Driver-Blade	12	95-1726	3	Screw-Taptite
7	131-9683-03	1	Blade	13	130-6709	1	Cover-Belt (Rear)
9	105-6848-03	1	Accelerator-Blade	14	46-8091	2	Screw-HWH
				22	132-4472	1	Decal-Shroud

● Not serviced separately

■ Obtain parts from www.briggsandstratton.com

Transmission and Front Wheel Drive Assembly

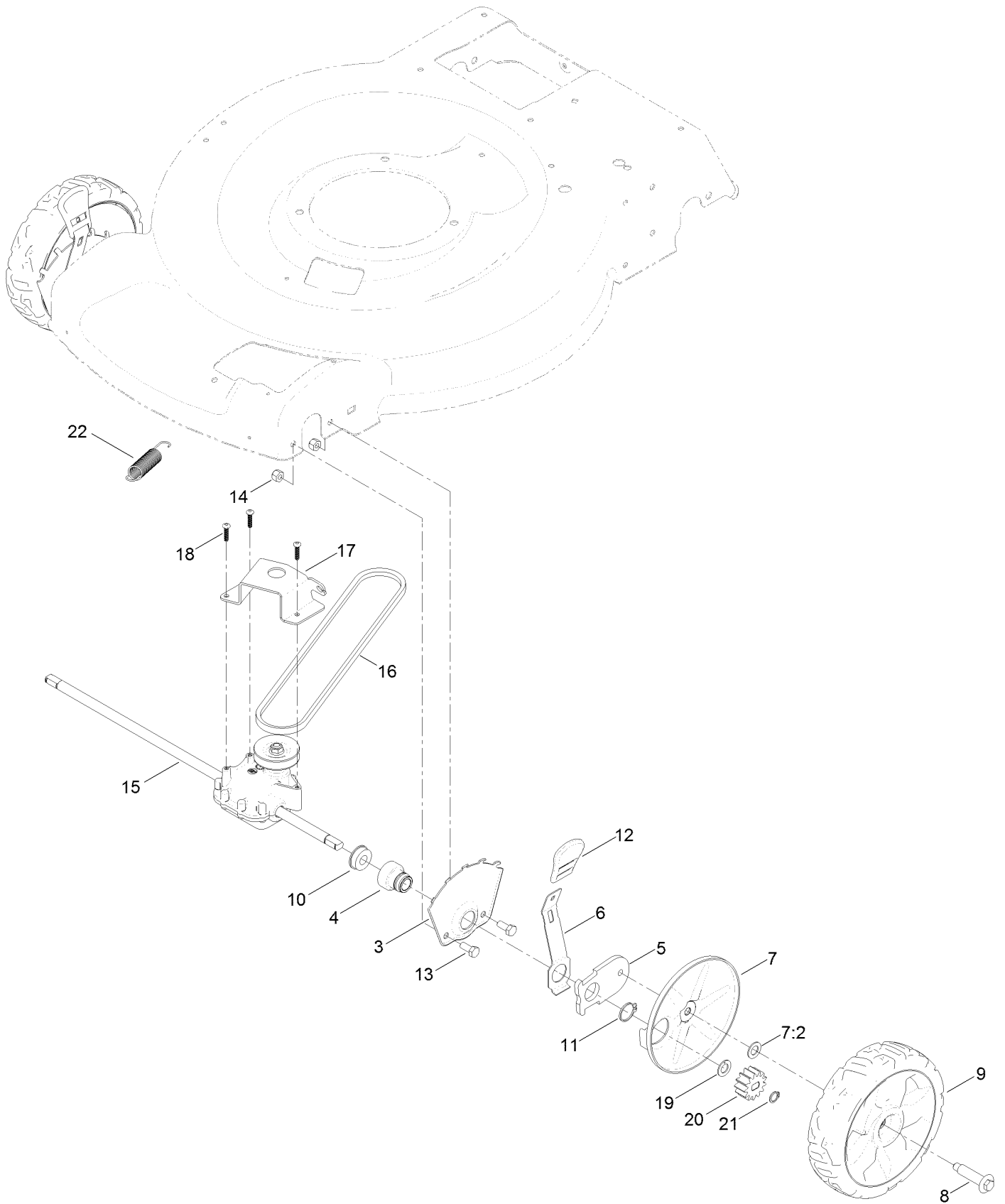

Transmission and Front Wheel Drive Assembly (continued)

<i>Ref.</i>	<i>Part Number</i>	<i>Qty.</i>	<i>Description</i>	<i>Ref.</i>	<i>Part Number</i>	<i>Qty.</i>	<i>Description</i>
3	115-1956-03	2	Plate-HOC, Front	13	322-3	4	Screw-HH
4	131-0836	2	Retainer-Bearing, HOC	14	3296-29	4	Nut-Lock, NI
5	105-1807	2	Arm-Pivot, Front	15	121-9180	1	Transmission ASM
6	105-1809	2	Arm-Spring	16	71-9450	1	V-Belt
7	131-4513	2	Wheel Cover ASM	17	114-7978-03	1	Bracket-Transmission
7:2	614426	1	Washer-Stepped	18	108-7476	3	Screw-Plastite
8	614650	2	Bolt-Shoulder	19	110-7191	2	Washer-Thrust
9	130-6711	2	8 Inch Wheel ASM (Front)	20	131-0896	2	Gear-Pinion, 13T
10	104-8699	2	Bearing-Ball	21	32151-61	2	Ring-Retaining
11	32151-36	2	Ring-Retaining	22	131-4560	1	Spring-Extension
12	110-0549	2	Knob-HOC				

Rear Wheel and Height-of-Cut Assembly

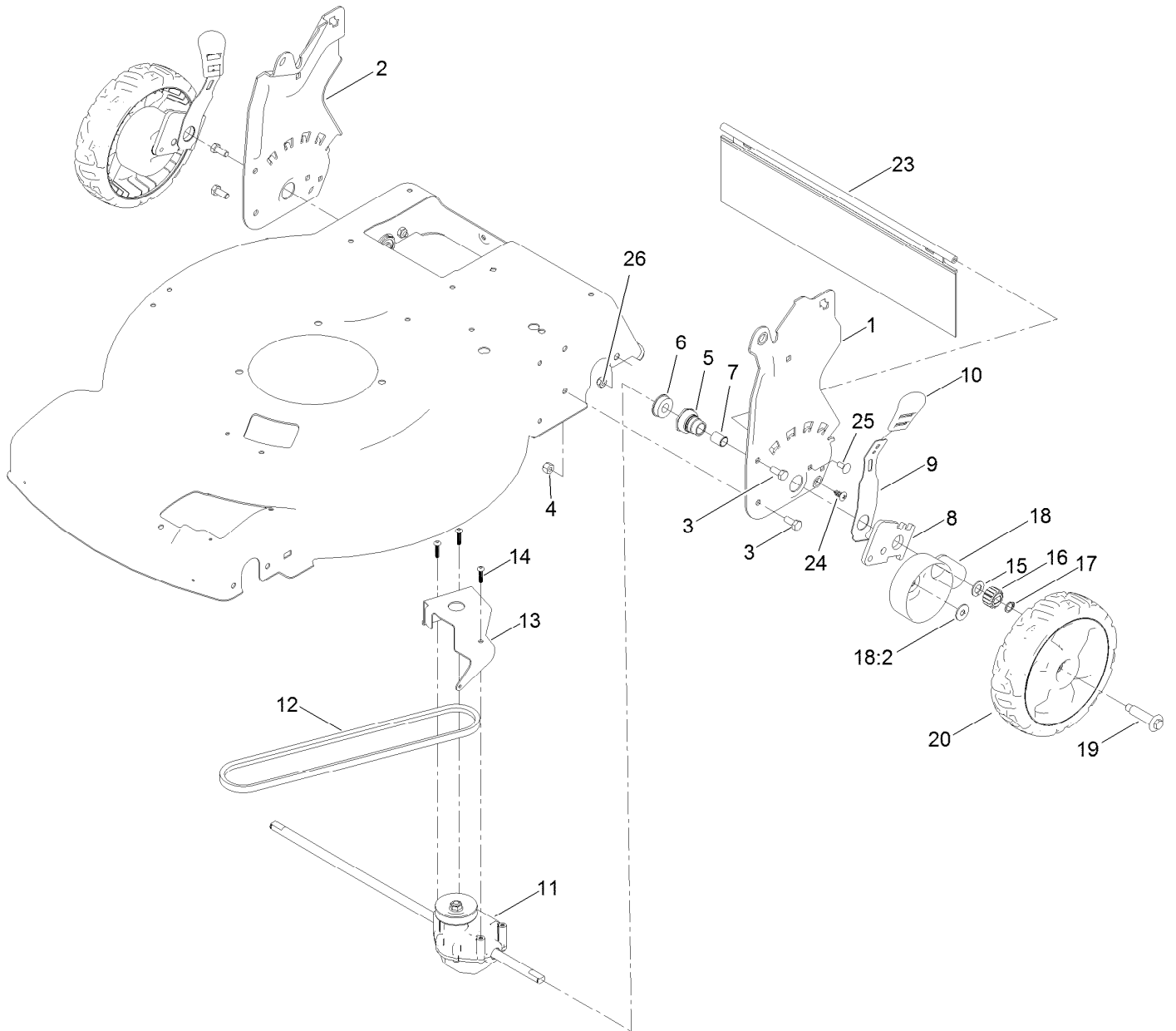

Rear Wheel and Height-of-Cut Assembly (continued)

<i>Ref.</i>	<i>Part Number</i>	<i>Qty.</i>	<i>Description</i>	<i>Ref.</i>	<i>Part Number</i>	<i>Qty.</i>	<i>Description</i>
1	131-9693-03	1	Plate-HOC, LH	14	108-7476	3	Screw-Plastite
2	131-9694-03	1	Plate-HOC, RH	15	110-7191	2	Washer-Thrust
3	322-3	4	Screw-HH	16	131-0875	2	Gear-Pinion, 15T
4	3296-29	4	Nut-Lock, NI	17	32151-61	2	Ring-Retaining
5	108-9779	2	Retainer-Bushing, HOC	18	132-4531	2	Cover-Gear, ASM
6	104-8699	2	Bearing-Ball	18:2	614426	1	Washer-Stepped
7	108-9782	2	Bushing-Sleeve	19	614650	2	Bolt-Shoulder
8	132-4459	2	Arm-Pivot, Rear	20	130-6714	2	8 Inch Wheel Gear ASM
9	108-9780	2	Arm-Spring	23	120-7012	1	Shield-Trailing
10	110-0549	2	Knob-HOC	24	117-1092	2	Screw-PTH
11	121-9178	1	Transmission ASM	25	3229-11	2	Screw-CARR
12	115-4669	1	Belt-V	26	3296-16	2	Nut-Lock, NI
13	114-7977-03	1	Bracket-Transmission				

Handle Assembly

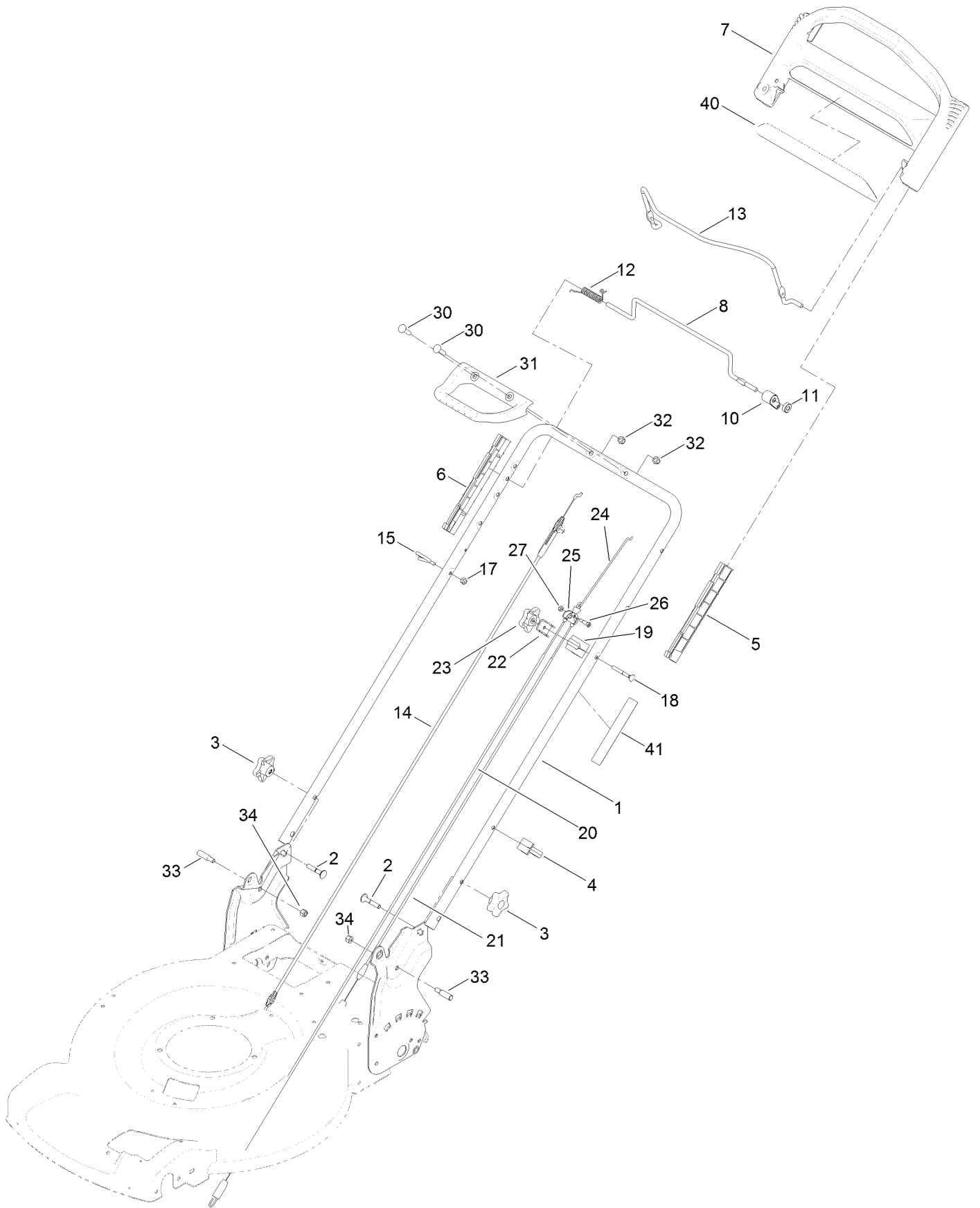

Handle Assembly (continued)

<i>Ref.</i>	<i>Part Number</i>	<i>Qty.</i>	<i>Description</i>	<i>Ref.</i>	<i>Part Number</i>	<i>Qty.</i>	<i>Description</i>
1	131-9695-05	1	Handle	19	130-6716	1	Mount-Cable, Traction
2	131-9663	2	Screw-CARR	20	130-6717	1	Cable-Traction, Front
3	117-5976	2	Knob-Handle	21	130-6718	1	Cable-Traction, Rear
4	114-7988	1	Guide-Cable	22	130-6704	1	Clamp-Cable
5	105-6842	1	Guide-LH	23	131-0897	1	Knob-Handle, Locking
6	105-6841	1	Guide-RH	24	131-4559	1	Linkage,Equalizer
7	104-8678	1	Handle-Control	25	130-6719	1	Yoke-Cable
8	99-1588	1	Bar-Control, Traction	26	132-4519	1	Screw-Shoulder
10	127-6842	1	Lever-Traction	27	3296-2	1	Nut-Lock, NI
11	130-2343	1	Spacer	30	99-6005	2	Bolt-Carriage
12	121-9118	1	Spring-Torsion	31	131-0847	1	Handle-Assist, Traction
13	131-0880-03	1	Bail-Brake	32	131-4535	2	Nut-Acorn
14	115-8437	1	Cable-Brake	33	131-4591	2	Bolt-Shoulder
15	86-9671	1	Guide-Rope	34	3296-29	2	Nut-Lock, NI
17	3296-73	1	Nut-Lock, NI	40	131-4539	1	Decal-Drive, Automatic
18	92-2269	1	Screw-Handle	41	132-4470	1	Decal-Traction, Adjust

Attachments and Accessories

For 20960 55cm Recycler Lawn Mower

Product Name	Model/Part
Fuel Stabilizer .05 oz	130-2393
AWD Replacement Bag and Frame Kit	131-4556
Traction Assist Handle Kit.....	131-4590
Lawn Striping Kit with 22in Roller.....	20601

Notes:

Notes:

Notes:



Count on it.