



MODEL NO. 03800TE—60001 & UP
MODEL NO. 03801TE—60001 & UP

**OPERATOR'S
MANUAL**

REELMASTER® 6500-D
2- & 4-WHEEL DRIVE TRACTION UNITS



PE

Table of Contents

IDENTIFICATION & ORDERING	2	Replacement	26
SAFETY INSTRUCTIONS	4	Operating Characteristics	27
SYMBOL GLOSSARY	7	MAINTENANCE	28
SPECIFICATIONS	10	Greasing Bearings And Bushings	28
BEFORE OPERATING	11	Service Interval Chart	29
Check the Engine Oil	11	Air Cleaner Maintenance	30
Check the Cooling System	11	Engine Oil And Filter	31
Fill the Fuel Tank	12	Fuel System	32
Check the Hydraulic Fluid	12	Engine Cooling System	32
Check the Planetary Gear Drive Oil	14	Engine Fan Belt	32
Check the Rear Axle Lubricant (Model 03801)	14	Changing Hydraulic Fluid	33
Check the Tire Pressure	14	Replacing Hydraulic Filter	33
Check Reel-To-Bedknife Contact	15	Checking Hydraulic Lines And Hoses	34
Check the Torque Of the Wheel Nuts	15	Adjusting Traction Drive For Neutral	34
KNOW YOUR CONTROLS	16	Adjusting Cutting Unit Lift Rate	35
OPERATING INSTRUCTIONS	18	Adjusting Service Brakes	35
Starting And Stopping	18	Changing Planetary Gear Drive Oil	35
Priming Fuel System	19	Rear Wheel Toe-in	36
Automatic Clip Control	19	Fuses	37
Selecting Clip Rate (Reel Speed)	20	Backlapping	37
Clip Rate Selection Chart	21	PREPARATION FOR SEASONAL STORAGE	48
Reel Control Light	22		
Pushing or Towing Machine	22		
Diagnostic Light	23		
Diagnostic ACE Display	23		
Checking Interlock Switches	24		
Hydraulic Solenoid Valve Functions	26		
Height-of-Cut Selection Potentiometer			

PROTOTYPE

Safety

Training

1. Read the instructions carefully. Be familiar with the controls and the proper use of the equipment.
2. Never allow children or people unfamiliar with these instructions to use the lawn mower. Local regulations may restrict the age of the operator.
3. Never mow while people, especially children, or pets are nearby.
4. Keep in mind that the operator or user is responsible for accidents or hazards occurring to other people or their property.
5. Do not carry passengers.
6. All drivers should seek and obtain professional and practical instruction. Such instruction should emphasize:
 - the need for care and concentration when working with ride-on machines;
 - control of a ride-on machine sliding on a slope will not be regained by the application of the brake. The main reasons for loss of control are:
 - insufficient wheel grip;
 - being driven too fast;
 - inadequate braking;
 - the type of machine is unsuitable for its task;
 - lack of awareness of the effects of ground conditions, especially slopes;
 - incorrect hitching and load distribution.

Preparation

1. While mowing, always wear substantial footwear and long trousers. Do not operate the equipment when barefoot or wearing open sandals.
2. Thoroughly inspect the area where the equipment is

to be used and remove all objects which may be thrown by the machine.

3. **WARNING—Petrol is highly flammable.**

- Store fuel in containers specifically designed for this purpose.
- Refuel outdoors only and do not smoke while refueling.
- Add fuel before starting the engine. Never remove the cap of the fuel tank or add petrol while the engine is running or when the engine is hot.
- If petrol is spilled, do not attempt to start the engine but move the machine away from the area of spillage and avoid creating any source of ignition until petrol vapors have dissipated.
- Replace all fuel tanks and container caps securely.

4. Replace faulty silencers.

Operation

1. Do not operate the engine in a confined space where dangerous carbon monoxide fumes can collect.
2. Mow only in daylight or in good artificial light.
3. Before attempting to start the engine, disengage all blade attachment clutches and shift into neutral.
4. Do not use on slopes of more than:
 - Never mow side hills over 5°
 - Never mow uphill over 10°
 - Never mow downhill over 15°
5. Remember there is no such thing as a “safe” slope. Travel on grass slopes requires particular care. To guard against overturning:
 - do not stop or start suddenly when going up or downhill;

- engage the clutch slowly, and always keep the machine in gear, especially when travelling downhill;
 - machine speeds should be kept low on slopes and during tight turns;
 - stay alert for bumps and hollows and other hidden hazards;
 - never mow across the face of the slope, unless the lawn mower is designed for this purpose.
6. Use care when pulling loads or using heavy equipment.
 - Use only approved drawbar hitch points.
 - Limit loads to those you can safely control.
 - Do not turn sharply. Use care when reversing.
 - Use counterweight(s) or wheel weights when suggested in the instruction handbook.
 7. Watch out for traffic when crossing or near roadways.
 8. Stop the blades rotating before crossing surfaces other than grass.
 9. When using any attachments, never direct discharge of material toward bystanders nor allow anyone near the machine while in operation .
 10. Never operate the lawn mower with defective guards, shields or without safety protective devices in place.
 11. Do not change the engine governor settings or over-speed the engine. Operating the engine at excessive speeds may increase the hazard of personal injury.
 12. Before leaving the operator's position:
 - disengage the power take-off and lower the attachments;
 - change into neutral and set the parking brake;
 - stop the engine and remove the key.
 13. Disengage the drive to attachments when transporting or not in use.
 14. Stop the engine and disengage the drive to the attachment
 - before refueling;
 - before removing the grass catcher;
 - before making height adjustments unless the adjustment can be made from the operator's position.
 - before clearing blockages;
 - before checking, cleaning or working on the lawnmower;
 - after striking a foreign object. Inspect the lawnmower for damage and make repairs before restarting and operating the equipment.
 15. Reduce the throttle setting during engine runout and, if the engine is provided with a shutoff valve, turn the fuel off at the conclusion of mowing.

Maintenance and Storage

1. Keep all nuts, bolts and screws tight to be sure the equipment is in safe working condition.
2. Never store the equipment with petrol in the tank inside a building where fumes may reach an open flame or spark.
3. Allow the engine to cool before storing in any enclosure.
4. To reduce the fire hazard, keep the engine, silencer, battery compartment and petrol storage area free of grass, leaves, or excessive grease.
5. Check the grass catcher frequently for wear or deterioration.
6. Replace worn or damaged parts for safety.
7. If the fuel tank has to be drained, this should be done outdoors.
8. Be careful during adjustment of the machine to prevent entrapment of the fingers between moving blades and fixed parts of the machine.
9. On multi-bladed machines, take care as rotating one

blade can cause other blades to rotate.

10. When the machine is to be parked, stored or left unattended, lower the cutting means unless a positive mechanical lock is used.

Sound & Vibration Levels

Sound Levels

This unit has an equivalent continuous A-weighted sound pressure at the operator ear of: 82 dB(A), based on measurements of identical machines per 84/538/EEC.



Vibration Levels



This unit has a vibration level of 2.5 m/s² at the posterior, based on measurements of identical machines per ISO 2631 procedures.

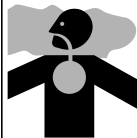

This unit does not exceed a vibration level of 0.5 m/s² at the posterior based on measurements of identical machines per ISO 2631 procedures.

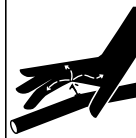
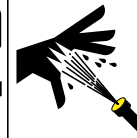
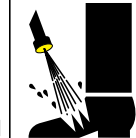
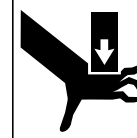
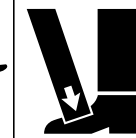

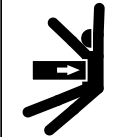
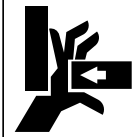
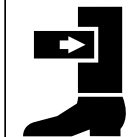
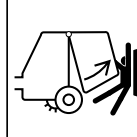
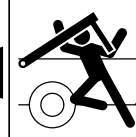
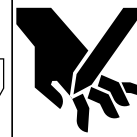

PROTOTYPE

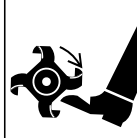
Symbol Glossary

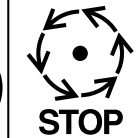
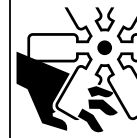
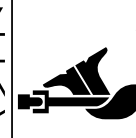
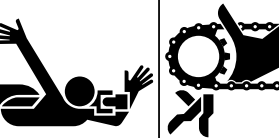

							
Caustic liquids, chemical burns to fingers or hand	Poisonous fumes or toxic gases, asphyxiation	Electrical shock, electrocution	High pressure fluid, injection into body	High pressure spray, erosion of flesh	High pressure spray, erosion of flesh	Crushing of fingers or hand, force applied from above	Crushing of toes or foot, force applied from above

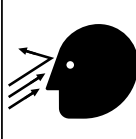
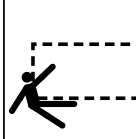
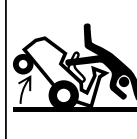
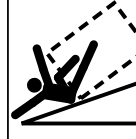
							
Crushing of whole body, applied from above	Crushing of torso, force applied from side	Crushing of fingers or hand, force applied from side	Crushing of leg, force applied from side	Crushing of whole body	Crushing of head, torso and arms	Cutting of fingers or hand	Cutting of foot

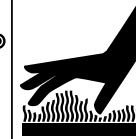
						
Cutting or entanglement of foot, rotating auger	Severing of foot, rotating knives	Severing of fingers or hand, impeller blade	Wait until all machine components have completely stopped before touching them	Severing of fingers or hand, engine fan	Whole body entanglement, implement input drive line	Fingers or hand entanglement, chain drive

							
Hand & arm entanglement, belt drive	Thrown or flying objects, whole body exposure	Thrown or flying objects, face exposure	Runover/backover, (relevant machine to appear in dashed box)	Machine tipping, riding mower	Machine rollover, ROPS (relevant machine to appear in dashed box)	Stored energy hazard, kickback or upward motion	Hot surfaces, burns to fingers or hands

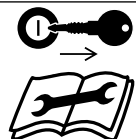
							
Explosion	Fire or open flame	Secure lifting cylinder with locking device before getting in hazardous area	Stay a safe distance from the machine	Stay clear of articulation area while engine is running	Do not open or remove safety shields while engine is running	Do not step on loading platform if PTO is connected to tractor & engine is running	Do not step

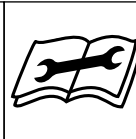
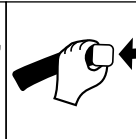
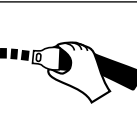
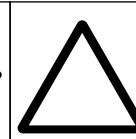
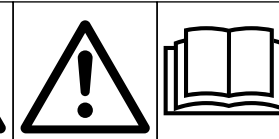
						
Shut off engine & remove key before performing maintenance or repair work	Riding on this machine is allowed only on a passenger seat & only if the driver's view is not hindered	Consult technical manual for proper service procedures	Fasten seat belts	Safety alert triangle	outline safety alert symbol	Read operator's manual

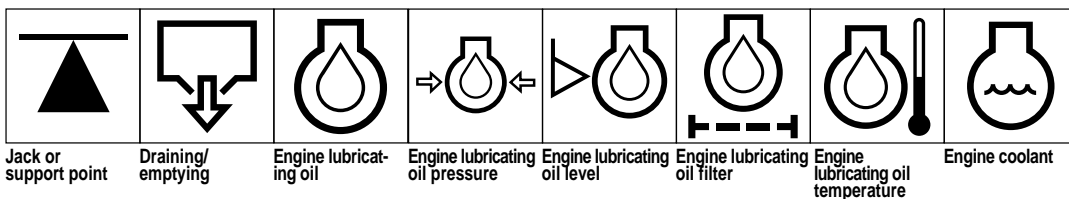
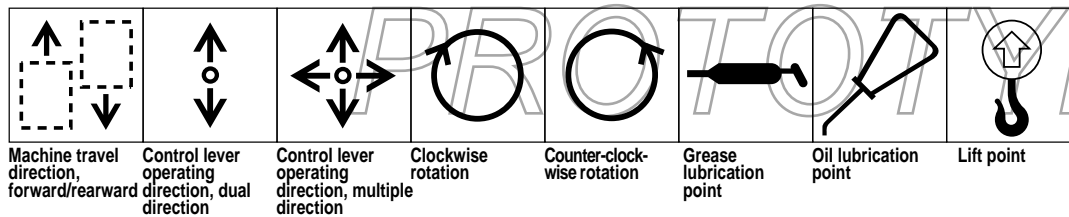
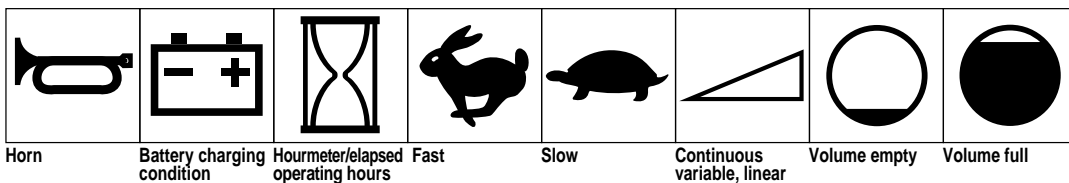
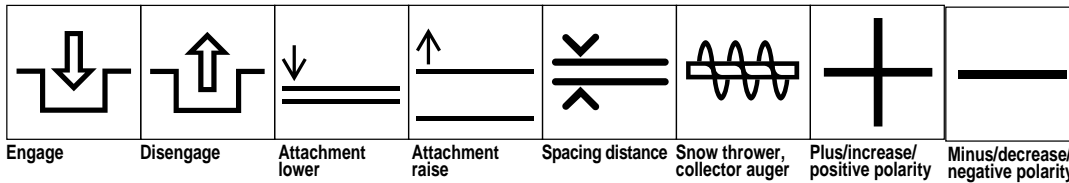
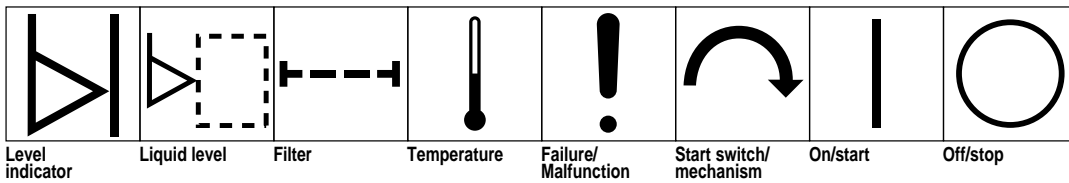
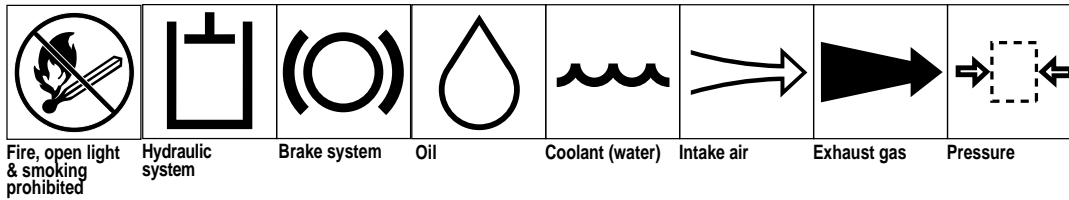
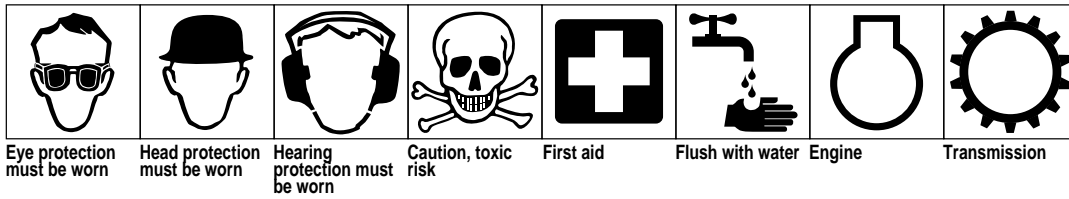

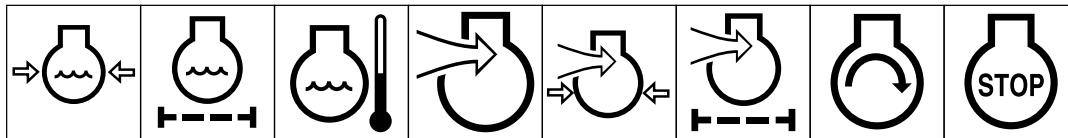

Engine coolant pressure Engine coolant filter Engine lubricating oil pressure Engine intake/combustion air Engine intake/combustion air pressure Engine intake/air filter Engine start Engine stop

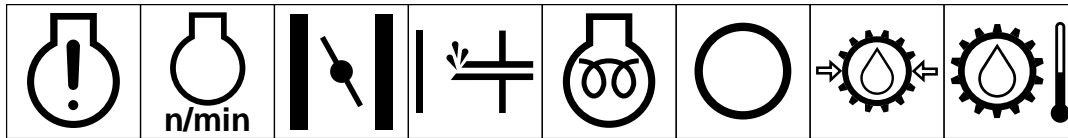

Engine failure/malfunction Engine rotational speed/frequency Choke Primer (start aid) Electrical preheat (low temperature start aid) Transmission oil Transmission oil pressure Transmission oil temperature

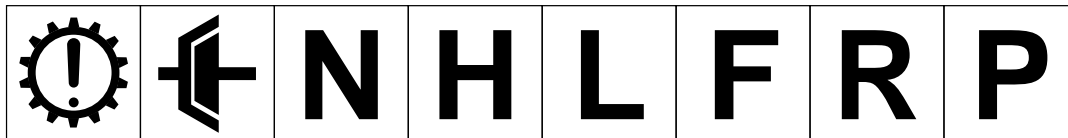

Transmission failure/malfunction Clutch Neutral High Low Forward Reverse Park

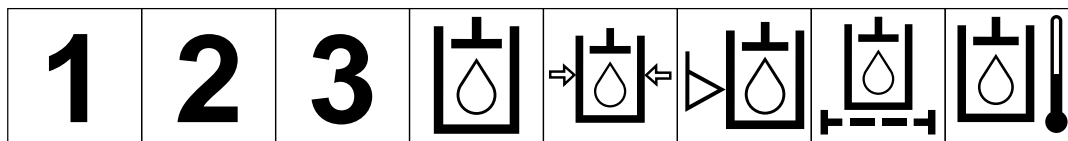

First gear Second gear Third gear (other #'s may be used until the maximum # of forward gears is reached.) Hydraulic oil Hydraulic oil pressure Hydraulic oil level Hydraulic oil filter Hydraulic oil temperature

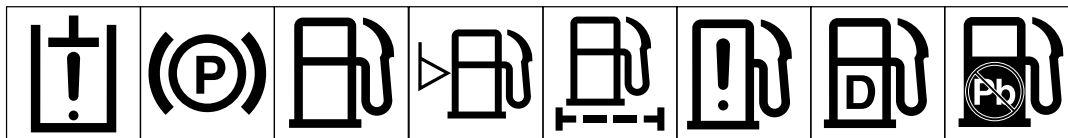

Hydraulic oil failure/malfunction Parking brake Fuel Fuel level Fuel filter Fuel system failure/malfunction Diesel fuel Unleaded fuel

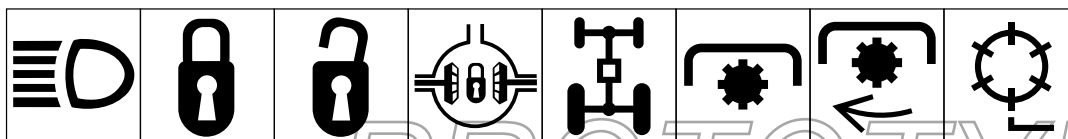

Headlights Lock Unlock Differential lock 4-Wheel drive Power Take-Off Power Take-Off, rotational speed Reel cutting element

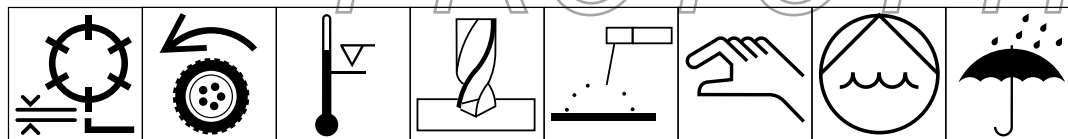

Reel cutting element, height adjustment Traction Above working temperature range Drilling Manual metal arc welding Manual 0356 Water pump 0626 Keep dry



0430 weight Do not dispose in the garbage CE logo

Specifications

Engine: Peugeot, 4-cylinder, 4-cycle, overhead cam, 116 cu. in (1.9 liter) displacement liquid-cooled diesel engine. 38 hp (28 kW); governed to 2500 rpm high idle; 23.5:1 compression ratio, 3.27" (83 mm) bore x 3.46" (88 mm) stroke. Automatic glow plug/starter interlock system. Heavy-duty, 2-stage, remote air cleaner.

Main Frame: All-welded formed steel frame, includes tie-down loops.

Cooling System: Rear-mounted, cross-flow agricultural type radiator; 7 fins per inch. 7.1 liter capacity. Air to oil cooler mounted to the rear of the radiator tips outward for cleaning. Removable oil cooler/radiator screen.

Fuel System: Rotary fuel injection pump with energized-to-run (ETR) fuel flow solenoid. Replaceable spin-on fuel filter/water separator with water sensor. Fuel capacity: 64 liter.

Traction System: Servo-controlled hydrostatic system driving double-planetary, gear-reduction, front-wheel drives. Foot pedal control of forward/reverse ground speed.

Toro 4-MaticR 4-Wheel Drive System only: Rear drive axle coupled to hydrostatic transmission via an overrunning clutch for full-time, on-demand 4-wheel drive. A Roll Over Protective Structure and seat belt are standard.

Ground Speed: 0–10 mph forward; 0–4 mph reverse.

Cutting Unit Drive System: Reel motors feature quick disconnect for removal or installation onto the cutting unit. Cutting units can be driven from either end.

Seat: Deluxe high-back suspension seat with adjustable fore and aft travel, weight and height. Tool box at the left side of the seat.

Steering System: Power steering with dedicated power source.

Tires: Two rear steering tires: 20 x 10.00–10, tubeless, 6-ply rating. Two front traction drive tires: 29 x 12.00–15 tubeless, 6-ply rating. Recommended tire pressure for front and rear tires is 15–20 psi.

Brakes: Individual totally enclosed, multi-disc, wet brakes and parking brakes on front traction wheels. Hydrostatic braking through traction drive.

Electrical Features: 12-volt, 530 cold-cranking amperes at 0° F (–18° C), 85-minute reserve capacity at 80° F (27° C), maintenance-free battery. 55-amp alternator with 1° C regulator/rectifier. Automotive-type electrical system. Seat switch, reel and traction interlock switches.

Controls: Foot-operated traction and brake pedals. Hand operated throttle, speed control lever, parking brake lock, ignition switch with automatic preheat cycle, single joy stick control for cutting unit on/off and lift lower. Cutting unit backlap switch under the operator's seat. Height-of-cut selector knob located under the control panel.

Gauges: Hour meter, speedometer, fuel gauge, temperature gauge, 4-bank warning lamp: oil pressure, water temperature, amps, and glow plug. 2-bank warning lamp: water in fuel, water level.

Diagnostics; The Automatic Control Electronics, ACET system allows precise timing and control of machine functions for maximum reliability. Toro standard diagnostic display connects to an electronic control unit to pinpoint any electrical problems quickly and easily. Available DATA LOGT system allows mechanic to find intermittent problems.

General Specifications (approx.):

Width-of-Cut:	244 cm
Overall Width:	213 cm
Transport	279 cm
Operational	305 cm
Overall Length:	
Height:	
Without roll-over protection system installed:	152 cm
With roll-over protection system installed:	213 cm
Weight:	
Model 03800	1,194 kg*
Model 03801	1,232 kg*
*With 5-Blade Cutting Units & full fluid levels	

Before Operating



CAUTION

Before servicing or making adjustments to the machine, stop the engine and remove the key from the switch.

CHECK THE ENGINE OIL (Fig. 2 & 3)

Crankcase capacity is 5 l with filter.

1. Park the machine on a level surface. Release the hood latch and open the hood.
2. Remove the dipstick from the tube cap, wipe clean and reinstall the dipstick into the tube cap. Pull it out again and check the oil level on the dipstick: The oil level must always be in the notch area on the dipstick.
3. If the oil level is low, remove the tube cap and add SAE 15W-40 CD oil until the level reaches top of notch on the dipstick. **DO NOT OVERFILL.**
4. Install the oil tube cap.
5. Close the hood and secure the latch.

CHECK THE COOLING SYSTEM (Fig. 4)



CAUTION

If the engine has been running, pressurized hot coolant can escape and cause burns if the degasser cap is removed. Allow the engine to cool at least 15 minutes or until the degasser cap is cool enough to touch without burning your hand.

Capacity of the system is 13 l.

Check the cooling system if the low water level light illuminates.

1. Park the machine on a level surface. Release the hood latch and open the hood.

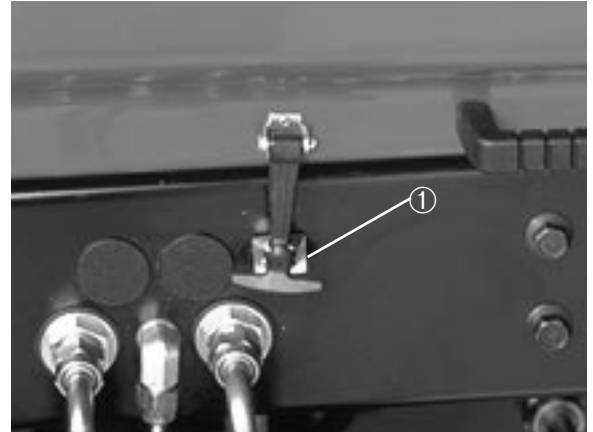

Figure 2

1. Hood latch

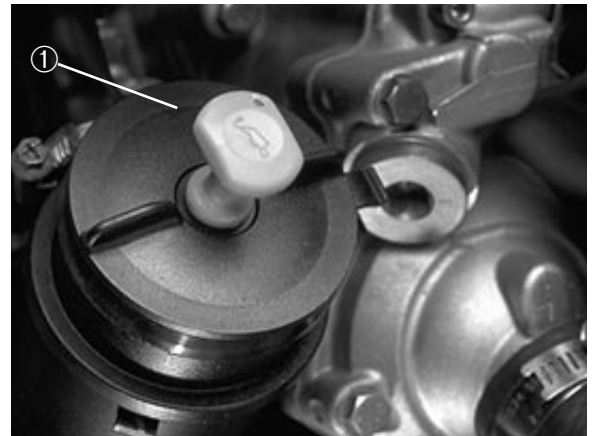

Figure 3

1. Dipstick/tube cap

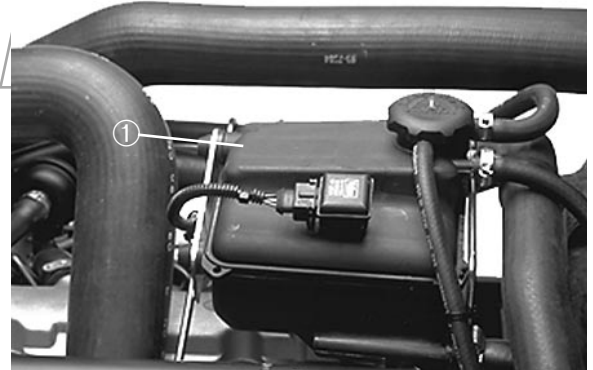

Figure 4

1. Degasser tank

2. Remove the degasser tank cap and check the coolant level. The level should be up to or above the tabs in the degasser tank, when the engine is cold.
3. If coolant is low, remove the degasser tank cap and add a 50/50 mixture of water and Peugeot-recommended anti-freeze (Toro Part No. 93-7213). **DO NOT USE WATER ONLY OR ALCOHOL/METHANOL BASE COOLANTS.**
4. Install the degasser tank cap.
5. Close the hood and secure the latch.

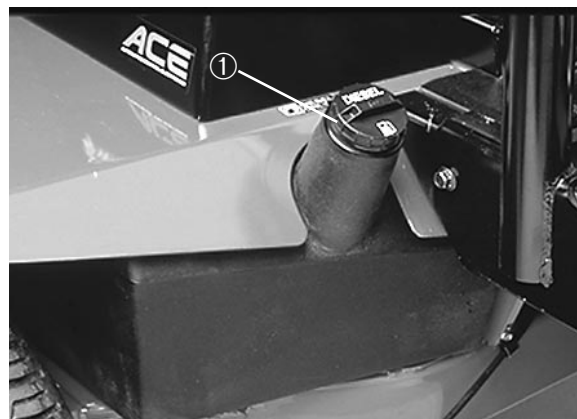

Figure 5

1. Fuel tank cap

FILL THE FUEL TANK (Fig. 5)

Fuel tank capacity is 56 liters.

1. Remove the fuel tank cap.
2. Fill the tank to about one inch below the top of the tank (not the filler neck) with No. 2 diesel fuel. Then install the cap.



DANGER

Because diesel fuel is flammable, use caution when storing or handling it. Do not smoke while filling the fuel tank. Do not fill the fuel tank while the engine is running, hot, or when the machine is in an enclosed area. Always fill the fuel tank outside and wipe up any spilled diesel fuel before starting the engine. Store fuel in a clean, safety-approved container and keep the cap in place. Use diesel fuel for the engine only; not for any other purpose.

CHECK HYDRAULIC FLUID (Fig. 6)

The hydraulic system is designed to operate on anti-wear hydraulic fluid. The machine's reservoir is filled at the factory with approximately 32 liters of Mobil 424 hydraulic fluid. Check the level of hydraulic fluid before the engine is first started and daily thereafter.

Group 1 Hydraulic Fluid (Recommended for ambient temperatures consistently below 38° C.):

ISO type 46/68 anti-wear hydraulic fluid

Mobil
Amoco

Mobil Fluid 424
Amoco 1000



Figure 6

1. Hydraulic tank cap

International Harvester	Hy-Tran
Texaco	TDH
Shell	Donax TD
Union Oil	Hydraulic/Tractor Fluid
Chevron	Tractor Hydraulic Fluid
BP Oil	BP HYD TF
Boron Oil	Eldoran UTH
Exxon	Torque Fluid
Conoco	Power-Tran 3
Kendall	Hyken 052
Phillips	HG Fluid

Note: The fluids within this group are interchangeable.

Group 2 Hydraulic Fluid (Biodegradable):

ISO VG 32/46 anti-wear hydraulic fluid

Mobil	EAL 224 H
-------	-----------

Note: The fluid in this group is not compatible with the fluids in group 1.

IMPORTANT: These hydraulic fluids are specified to allow optimal operation of the machine in a wide range of temperatures encountered. The group 1 fluids are a multi-viscosity hydraulic fluids which allows operation at lower temperatures without the increased viscosity, which is associated with straight viscosity fluids.

Note: When changing from one type of hydraulic fluid to the other, be certain to remove all the old fluid from the system, because some brands of one type are not completely compatible with some brands of the other type of hydraulic fluid.

IMPORTANT: Use only types of hydraulic fluids specified. Other fluids could cause system damage.

Note: A red dye additive for the hydraulic system fluid is available in 20 ml bottles. One bottle is sufficient for 15–23 l. of hydraulic fluid. Order Part No. 44-2500 from your Authorized Toro Distributor

1. Position the machine on a level surface, lower the cutting units and stop the engine.
2. Clean the area around the filler neck and the cap of the hydraulic tank. Remove the cap from the filler neck.
3. Remove the dipstick from the filler neck and wipe it with a clean cloth. Insert the dipstick into the filler neck; then remove it and check the level of fluid. Fluid level should be within 0.6 cm of the mark on the dipstick.

4. If the level is low, add fluid to raise the level to the full mark.
5. Install the dipstick and cap onto the filler neck.

CHECK THE PLANETARY GEAR DRIVE OIL (Fig. 7)

Check the oil if external leakage is noted. Use high-quality SAE 85W-140 wt. gear lubrication as replacement.

System capacity is 47.3 cl.

1. With the machine on a level surface, position the wheel so the check/drain plug is at either three or nine o'clock position.
2. Remove plug. Oil should be to bottom of the hole.
3. Add gear oil, if necessary, to bring fluid up to the correct level and install the plug.
4. Repeat steps 1–3 on the opposite gear assembly.

CHECK REAR AXLE LUBRICANT

(Model 03801 Only) (Fig. 8)

The rear axle is shipped from the factory filled with SAE 85W-140 wt. gear lubrication. Check the level before the engine is first started and every 400 hours thereafter. Capacity is 2.3 l. Visually inspect for leaks daily.

1. Position the machine on a level surface.
2. Remove a check plug from one end of the axle and make sure lubricant is up to bottom of hole. If the level is low, remove the fill plug and add enough lubricant to bring the level up to the bottom of the check plug holes.

CHECK TIRE PRESSURE

The tires are over-inflated for shipping. Therefore, release some of the air to reduce the pressure. Correct air pressure in the front and rear tires is 103–138 kPa.

IMPORTANT: Maintain even pressure in all tires to assure a good quality-of-cut and proper machine performance. DO NOT UNDER INFLATE.



Figure 7

1. Check/Drain plug

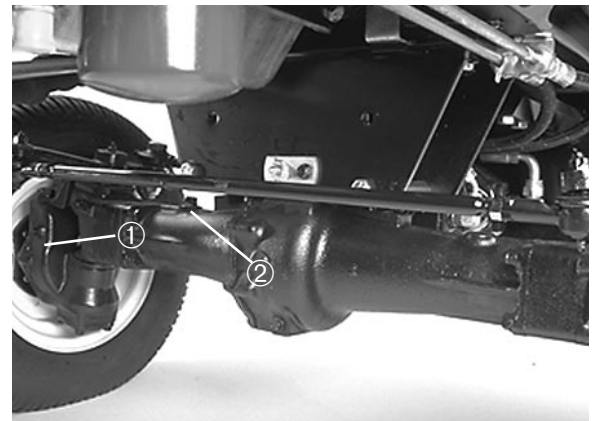

Figure 8

1. check plug
2. Fill plug

PROTOTYPE

CHECK REEL-TO-BEDKNIFE CONTACT

Each day before operating, check reel-to-bedknife contact, regardless of whether the quality of cut had previously been acceptable. There must be light contact across the full length of the reel and bedknife (refer to *Adjusting Reel to Bedknife in Cutting Unit Operator's Manual*).

CHECK THE TORQUE OF WHEEL NUTS OR BOLTS



CAUTION

Torque the front wheel nuts to 61–74 kPa and the rear wheel nuts to 115–135 kPa after 1–4 hours of operation and again after 10 hours of operation and every 200 hours thereafter. Failure to maintain proper torque could result in failure or loss of the wheel and may result in personal injury.

PROⁱ

Controls

Traction Pedal (Fig. 9)—Controls forward and reverse operation. Depress the top of the pedal to move forward and bottom to move backward. Ground speed depends on how far the pedal is depressed. For no-load, maximum ground speed, fully depress the pedal while the throttle is in FAST.

To stop, reduce foot pressure on traction pedal and allow it to return to center position.

Traction Speed Limiter (Fig. 9)—Preset this lever to limit the amount the traction pedal can be depressed in the forward direction to maintain a constant mowing speed.

Reel Control Light (Fig. 9)—When lit, indicates the machine is being operated in a way in which the automatic reel speed control cannot obtain the desired clip.

Speedometer (Fig. 9)—Indicates ground speed at which the machine is traveling.

Lower Mow/Raise Control Lever (Fig. 10)—The lever raises and lowers the cutting units and also starts and stops the reels.

Fuel Gauge (Fig. 10)—Indicates the level of fuel in the tank.

Engine Oil Pressure Warning Light (Fig. 10)—Indicates dangerously low engine oil pressure.

Key Switch (Fig. 10)—Three positions: OFF, ON / Preheat and START.

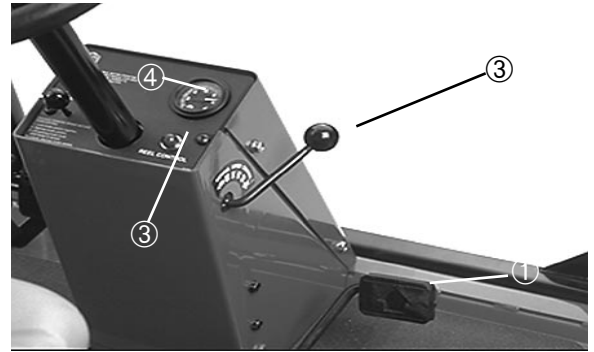

Figure 9

1. Traction pedal
2. Traction speed limiter
3. Reel control light
4. Speedometer



Figure 10

1. Lower mow/raise control lever
2. Fuel gauge
3. Engine coolant temperature gauge
4. Engine oil pressure warning light
5. Engine coolant temperature warning light
6. Glow plug indicator light
7. Charge indicator
8. Key switch
9. Throttle control
10. Enable/disable switch
11. Water-in-fuel light
12. Low-water level light

WARNING

The engine will not crank over until the glow plug lamp goes out. Glow plugs must complete their cycle before the controller will allow the engine to crank.

Throttle Control (Fig. 10)—Move the control forward to increase engine speed, rearward to decrease speed.

Engine Coolant Temperature Warning Light (Fig. 10)—The light illuminates and the engine shuts down when coolant reaches a dangerously high temperature.

Glow Plug Indicator Light (Fig. 10)—When lit, indicates the glow plugs are on.

Charge Indicator (Fig. 10)—Illuminates when the system charging circuit malfunctions.

Enable/Disable Switch (Fig. 10)—Used with lower mow / raise control lever to operate the reels.

Water-in-the-fuel Light (Fig. 10)—Warns of water in the fuel system.

Low Water Level Light (Fig. 10)—Warns that the coolant water level is low.

Height-of-Cut Selector Knob (Fig. 11)—Turning the knob to the appropriate setting informs the electronic controller at what height-of-cut the machine is being operated so desired clip may be obtained. See section in manual for operating instructions. The knob is located under the control panel.

Hour Meter (Fig. 11)—Shows total hours the machine has been operated.

Backlap Switch (Fig. 12)—Used with the lower mow / raise control lever for backlapping operation. This switch is located under seat plate. Refer to *Cutting Unit Maintenance, Backlapping*.

Brake Pedals (Fig. 13)—Two foot pedals operate individual wheel brakes for turning assistance, parking and to aid better sidehill traction. A locking pin connects the pedals for parking brake operation and transport.

Parking Brake Latch (Fig. 13)—A knob on the left side of the console actuates the parking brake lock. To engage the parking brake, connect the pedals with the locking pin, push down on both pedals and pull the parking brake latch out. To release the parking brake, depress both pedals until the parking brake latch retracts.

Seat (Fig. 14)—Seat adjusting lever allows 10 cm fore and aft adjustment. Seat adjusting knob adjusts seat for operator's weight. To adjust the seat fore and aft, pull the lever on the left side of the seat assembly outward. After moving the seat, release the lever to lock the seat into position. To adjust for operator's weight, turn the spring tension knob: clockwise to increase tension, counterclockwise to decrease spring tension

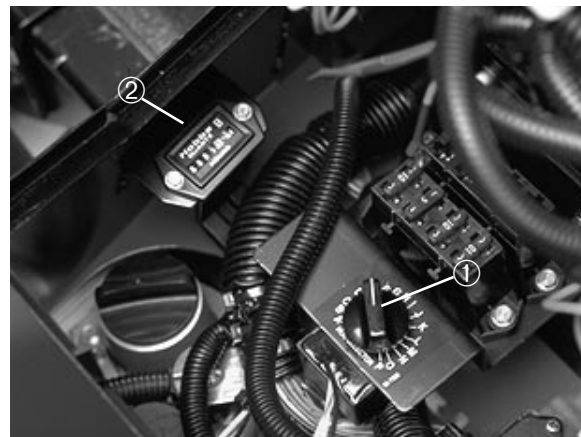

Figure 11

1. HOC selector knob
2. Hour meter



Figure 12

1. Backlap switch

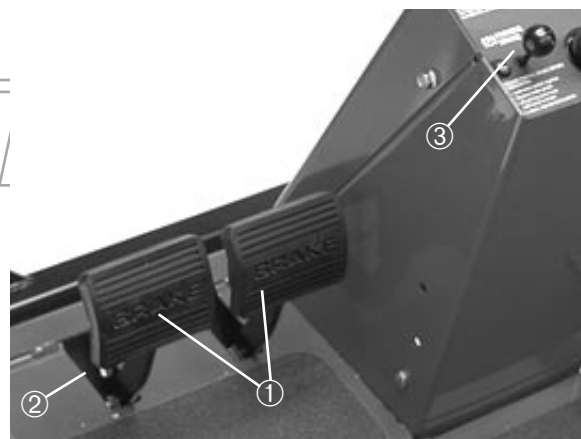

Figure 13

1. Brake pedals
2. Parking brake latch
3. Locking pin



Figure 14

1. Seat adjusting lever
2. Seat adjusting knob

Operating Instructions



CAUTION

Before servicing or making adjustments to the machine, stop the engine and remove the key from the switch.

STARTING AND STOPPING

1. Sit on the seat; keep your foot off the traction pedal. Assure the parking brake is engaged, the traction pedal is in NEUTRAL, the throttle is in the SLOW position and the ENABLE/DISABLE switch is in the DISABLE position.



WARNING

The engine will not crank over until the glow plug lamp goes out. Glow plugs must complete their cycle before the controller will allow the engine to crank.

2. Turn the ignition switch to ON/Preheat position. An automatic timer will control preheat for approximately 6 seconds. The engine will not crank until preheat light goes off. After preheat, turn the key to START position. **CRANK THE ENGINE FOR NO LONGER THAN 15 SECONDS.** Release the key when the engine starts. If additional preheat is required, turn the key to the OFF position, then to ON/preheat position. Repeat this process as required.

TOTYPE

3. Run the engine at idle speed or partial throttle until the engine warms up.
4. To stop, move all controls to NEUTRAL and set the parking brake. Return the throttle to the idle position, turn the key to OFF and remove it from the switch.

PRIMING THE FUEL SYSTEM (Fig. 15 & 16)

IMPORTANT: The fuel system may need to be primed when a new engine is started for the first time, if it runs out of fuel or if maintenance is performed on the fuel system.

1. Unlatch and raise the hood.
2. Insert a 3/16" hose over the bleed screw and run the other end into a container to catch the fuel.
3. Loosen the fuel filter/water separator bleed screw (Fig.) a few turns. Pump the priming plunger until a steady stream of fuel comes out of the hole in the bleed screw. When the fuel stops foaming, tighten the bleed screw during the downstroke of the priming plunger. Wipe up any spilled fuel.
4. Pump the priming plunger until you feel resistance. Try to start the engine. If the engine does not start, repeat step 3.

Note: It may be necessary to bleed the air out of the fuel line between the fuel filter/water separator and the injection pump. To do this, loosen the fitting on the injection pump (Fig. 16) and repeat the bleeding procedure.



Figure 15

1. Primer plunger
2. Bleed screw

AUTOMATIC CLIP CONTROL

The RM 6500-D is equipped with an electronic controller which is programmed to achieve automatic clip control. The machine will automatically adjust the reel speed to attain the desired clip as the traction speed changes. For the controller to know what clip is desired, the software must have been properly set, by your distributor or dealer, to either 5 or 11 blade and the height-of-cut selector knob must be properly set.

The range of possible reel speeds is a minimum of about 500 RPM and a maximum of about 1400 RPM. As long as the desired clip requires a reel speed within this range, the machine will maintain the desired clip. If the traction speed is too slow or too fast to allow the desired clip, the Reel Control light (on the front control panel)

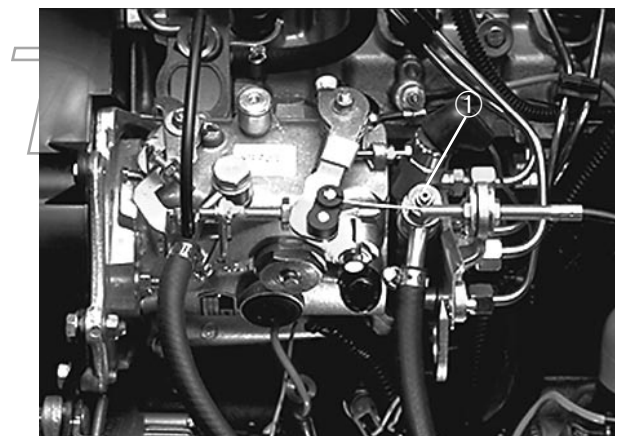

Figure 16

1. Injection pump fitting

will illuminate, warning that the desired clip is not being maintained. For example, if the traction speed is zero, the reels will still run at the minimum speed of about 500 RPM, which will result in a clip smaller than desired and cause the Reel Control light to illuminate. The approximate ranges of traction speed which will result in the desired clip are as follows for several of the possible heights of cut:

SAMPLES OF TRACTION SPEED RANGES FOR VARIOUS HEIGHTS OF CUT			
No. of Blades per C.U.	Height of Cut	Minimum Traction Speed	Maximum Traction Speed
11	.97 cm	3 kmh	9.6 kmh
11	1.27 cm	4.2 kmh	12.2 kmh
5	1.60 cm	2.4 kmh	7.2 kmh
5	2.24 cm	3.4 kmh	5.5 kmh

* Procedure for maintaining proper clip rate:

1. Set HOC selector knob to correct letter setting (Per chart located under seat plate).
2. Maintain ground speed which prevents reel control light from illuminating

SELECTING CLIP RATE (REEL SPEED)

To achieve a consistent, high quality of cut, and a uniform after-cut appearance, the reel speed be matched to the height of cut. The machine controller is programmed to automatically control the reel speed to give the correct clip, even as traction speed changes. To control the reel speed, the controller must know the height of cut of the machine, and whether the machine is equipped with 5- or 11-blade reels.

Adjust the height-of-cut selector knob as follows:

1. Insure the configuration screen, set by the distributor, is on the correct setting. (5 or 11 blade.)
2. Verify the height-of-cut setting on the cutting units. Using the column of the chart above or the chart under the seat plate, listing either 5- or 11-blade reels, find the height of cut listing nearest the actual height-of-cut setting. Look across the chart to find the letter corresponding to that height of cut.
3. Turn the height-of-cut selector knob to the letter setting determined in step 2.
4. Operate the machine for several days, then examine the cut to

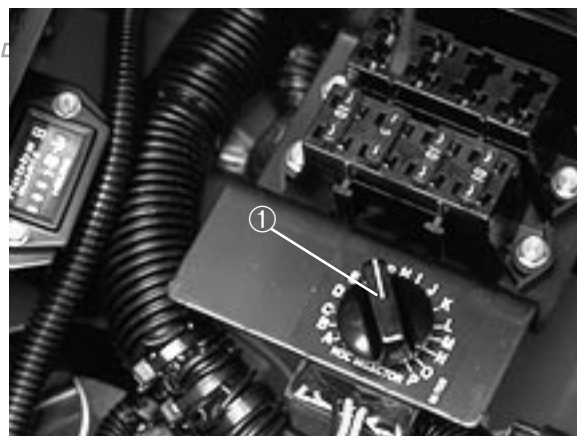

ensure satisfaction with the quality of cut. The height-of-cut knob may be set one position on either side of the position on the chart to account for differences in grass condition, grass length removed, and personal preference of the superintendent. For a cut with more grass removed but slightly more clip visibility, move the height-of-cut selector knob one position higher than specified. For a cut with less grass removed and slightly less clip visibility, move the height-of-cut selector one position lower than specified.

Full Speed—There may be times when it is desirable for the reels to run at full speed regardless of the machine’s traction speed. Examples of this are vertical cutting or heavy scalping. In such cases, the height-of-cut selector knob may be set to position "A" which will command the machine controller to run the reels at full speed at all times.

CLIP RATE (REEL SPEED) SELECTION CHART

11-Blade Cutting Unit		8-Blade Cutting Unit	
Height-of-Cut Knob Selection	Height of Cut	Height-of-Cut Knob Selection	Height of Cut
A	FULL SPEED	A	FULL SPEED
B	9.6 mm	B	16.0 mm
C	10.7 mm	C	17.3 mm
D	11.7 mm	D	18.5 mm
E	12.7 mm	E	19.6 mm
F	13.7 mm	F	20.8 mm
G	14.7 mm	G	21.8 mm
H	15.7 mm	H	22.9 mm
I	16.8 mm	I	23.9 mm
J	17.8 mm	J	24.9 mm
K	18.8 mm	K	25.9 mm
L	19.8 mm	L	26.9 mm
M	20.8 mm	M	27.9 mm
N	21.8 mm	N	29.0 mm
O	22.9 mm	O	30.1 mm
P	23.9 mm	P	31.0 mm

FULL SPEED—Cutting units will always run at full speed in this position

REEL CONTROL LIGHT

The Reel Control light, located on the front control panel, is used to give feedback to the operator whether the machine controller can achieve the desired clip. If the machine is operated at a traction speed that is too low or too high, the machine controller may not be able to set the reel speed at the required value for the desired clip. If this occurs, the Reel Control light will illuminate.

If the Reel Control light illuminates, it means one of the following things:

1. The machine is being operated at a traction speed too slow to allow desired clip.
or
2. The machine is being operated at a traction speed too fast to allow desired clip. To correct the situation, change the traction speed until the light goes out.
or
3. A foreign object, such as a stick, piece of turf, etc. is restricting reel rotation.

If changing the traction speed or removing the foreign object does not cause the light to go out, and the Reel Control light remains illuminated regardless of traction speed, then a service issue is indicated. In this case, refer to the *Diagnostic Display* section of this manual, check the service manual or contact your local authorized Toro Distributor.

PUSHING OR TOWING THE MACHINE

In an emergency, the Reelmaster 6500-D can be moved by actuating the by-pass valve in the variable displacement hydraulic pump and pushing or towing the machine.

IMPORTANT: Do not push or tow the machine faster than 2–3 mph (3–4.8 km/hr) because internal transmission damage may occur. The by-pass valve must be open whenever the machine is pushed or towed.

1. The by-pass valve is located on the top of variable displacement pump (Fig. 18). Rotate the valve 90° in either direction, to open and allow oil to by-pass internally. Because fluid is by-passed, the machine can be moved—slowly—without damaging the transmission.
2. Close the by-pass valve before starting the engine. However, do not exceed 7–11 Nm torque to close the valve.

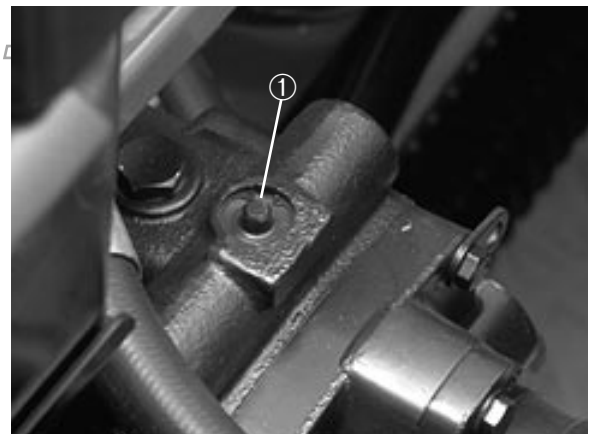

Fig. 18

IMPORTANT: Running the engine with the by-pass valve open will cause the transmission to overheat.

DIAGNOSTIC LIGHT (Fig. 19)

The RM 6500-D is equipped with a diagnostic light which indicates whether or not the electronic controller is functioning correctly. The diagnostic light is located on the steering tower panel. When the electronic controller is functioning correctly and the key switch is moved to the ON position, the controller diagnostic light will be illuminated for approximately 6 seconds. The light will not illuminate if the controller detects a malfunction in the electrical system.

If the diagnostic light is not illuminated when the key switch is in the ON position, this indicates that the electronic controller is not operating. Possible causes are:

1. Loopback connector (under control panel cover) is not connected.
2. The electronic controller light is burned out.
3. Fuses are blown.
4. The light is not functioning correctly.

Check electrical connections, input fuses and the diagnostic light bulb to determine malfunction. Make sure the loopback connector is secured to the wire harness connector.

DIAGNOSTIC ACE DISPLAY

The RM 6500-D is equipped with an electronic controller which controls most machine functions. The controller determines what function is required for various input switches (i.e. seat switch, key switch, etc.) and turns on the outputs to actuate solenoids or relays for the requested machine function.

For the electronic controller to control the machine as desired, each of the input switches, output solenoids and relays must be connected and functioning properly.

The Diagnostic ACE display is a tool to help the user verify correct electrical functions of the machine.



Figure 19

1. Electronic controller light

CHECKING THE INTERLOCK SWITCHES

The purpose of the interlock switches is to prevent the engine from cranking or starting unless the traction pedal is in NEUTRAL, the Enable/Disable switch is in DISABLE and the Lower Mow/Raise control is in the neutral position. In addition, the engine will stop when the traction pedal is depressed with the operator off the seat.

To verify interlock switch function:

CAUTION

THE INTERLOCK SWITCHES ARE FOR THE PROTECTION OF THE OPERATOR AND BYSTANDERS, AND TO ENSURE CORRECT OPERATION OF THE MACHINE, SO DO NOT BYPASS OR DISCONNECT THEM. CHECK THEIR OPERATION DAILY TO INSURE THEY ARE OPERATING CORRECTLY. IF A SWITCH IS DEFECTIVE, REPLACE IT BEFORE OPERATING THE MACHINE. HOWEVER, DO NOT RELY ENTIRELY ON SAFETY SWITCHES, ALSO USE COMMON SENSE!



Figure 20

1. Wire harness and connectors

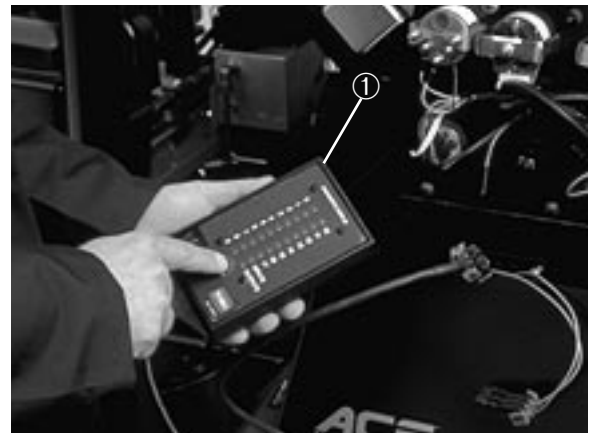

Figure 21

1. Park the machine on a level surface, lower the cutting units, stop the engine and engage the parking brake.
2. Open the control panel cover. Locate the wire harness and connector. Carefully unplug the loopback connector from the harness connector.
3. Connect the Diagnostic ACE display connector to the harness connector. Make sure the correct overlay decal is positioned on Diagnostic ACE display.
4. Turn the key switch to the ON position, but do not start the machine.

Note: The red text on the overlay decal refers to input switches and the green text refers to outputs.

5. The “inputs displayed” LED, on lower right column of the Diagnostic ACE, should be illuminated. If the “outputs displayed” LED is illuminated, press and release the toggle button on the Diagnostic ACE to change the LED to “inputs displayed”. Do not hold the button down.

PROTOTYPE

1. Diagnostic ACE

6. The Diagnostic ACE will illuminate the LED associated with each of the inputs when that input switch is closed.

Individually, change each of the switches from open to closed (i.e., sit on seat, engage the traction pedal, etc.), and note that the appropriate LED on Diagnostic ACE will blink on and off when corresponding switch is closed. Repeat on each switch that is possible to be changed by hand.

7. If switch is closed and appropriate LED does not turn on, check all wiring and connections to switch and/or check switches with an ohm meter. Replace any defective switches and repair any defective wiring.

The Diagnostic ACE also has the ability to detect which output solenoids or relays are turned on. This is a quick way to determine if a machine malfunction is electrical or hydraulic.

To verify output function:

1. Park the machine on a level surface, lower the cutting units, stop the engine and engage the parking brake.
2. Open the control panel cover. Locate the wire harness and connectors near the controller. Carefully unplug the loopback connector from the harness connector. Set the height-of-cut selector knob to position "A".
3. Connect the Diagnostic ACE connector to the harness connector. Make sure the correct overlay decal is positioned on Diagnostic ACE.
4. Turn the key switch to the ON position, but do not start the machine.

Note: The red text on the overlay decal refers to input switches and the green text refers to outputs.

5. The "outputs displayed" LED, on lower right column of the Diagnostic ACE, should be illuminated. If the "inputs displayed" LED is illuminated, press the toggle button on Diagnostic ACE to change LED to "outputs displayed".

Note: It may be necessary to toggle between "inputs displayed" and "outputs displayed" several times to do the following step. To toggle back and forth, press the toggle button once. This may be done as often as required. **DO NOT HOLD THE BUTTON.**

6. Sit on the seat and attempt to operate the desired function of the machine. The appropriate output LEDs should illuminate to indicate that the ECU is turning on that function. (Refer to the list below to be certain of the specified output LEDs.

Note: If any output LED is blinking, this indicates an electrical problem with that OUTPUT. Repair or replace defective electrical parts immediately. To reset a blinking LED, turn the key switch to "OFF", then back to "ON".

If no output LEDs are blinking, but the correct output LEDs do not illuminate, verify that the required input switches are in the correct positions for the function to occur.

If the output LEDs are on as specified, but the machine does not function properly, this indicates a non-electrical problem. Repair as necessary.

Note: Due to electrical system constraints, the output LEDs for "START", "PREHEAT" and "ETR/ALT" may not blink even though an electrical problem may exist for those functions. If the machine problem appears to be with one of these functions, check the electrical circuit with a volt/ohm meter to verify that no electrical problem exists to these functions.

If each input switch is in the correct position and functioning correctly, but the output LEDs are not correctly illuminated, this indicates an ECU problem. If this occurs, contact your Toro Distributor for assistance.

IMPORTANT: The Diagnostic ACE display must not be left connected to the machine. It is not designed to withstand the environment of the machine's every day use. When finished using the Diagnostic ACE, disconnect it from the machine and reconnect the loopback connector to the harness connector. The machine will not operate without the loopback connector installed on the harness. Store the Diagnostic

ACE in dry, secure location in the shop, not on the machine.

HYDRAULIC SOLENOID VALVE FUNCTIONS

Use the list below to identify and describe the different functions of the solenoids in the hydraulic manifold. Each solenoid must be energized to allow function to occur.

Solenoid	Function
VS1A,S1A,S2A	Front reel circuit
VS1B,S1B,S2B	Rear reel circuit
VS1A,S1A,S4A,S6A	Lift front wing cutting units
VS1A,S1A,S4A,S7A	Lift center cutting unit
VS1A,S1A,S4A,S4B	Lift rear cutting unit
S5A,S7A	Lower center cutting unit
S5A,S4B	lower rear cutting unit
S54,S6A	Lower front wing cutting units
VS1A,S3A	Backlap front cutting units
VS1B,S3B	Backlap rear cutting units

HEIGHT-OF-CUT SELECTION POTENTIOMETER REPLACEMENT

The height-of-cut selection potentiometer is factory calibrated. If the height-of-cut selection potentiometer must be replaced for any reason, the new potentiometer must be calibrated to assure the correct clip. (If the potentiometer is not calibrated correctly, the delivered clip may be as much as 2 or 3 settings different from the desired setting.) This calibration must be done by your Toro distributor.

OPERATING CHARACTERISTICS

Familiarization—Before mowing grass, practice operating the machine in an open area. Start and stop the engine. Operate in forward and reverse. Lower and raise the cutting units and engage and disengage the reels. When you feel familiar with the machine, practice operating up and down slopes at different speeds.

The brakes can be used to assist in turning the machine. However, use them carefully, especially on soft or wet grass conditions because the turf may be torn accidentally. Individual turning brakes may also be used to help

the uphill wheel slips and loses traction. If this situation occurs, depress uphill turn pedal gradually and intermittently until the uphill wheel stops slipping, thus, increasing traction on the downhill wheel.

WARNING: When operating the machine, always use the seat belt and roll-over protection system together.

Warning System—If a warning light comes on during operation, stop the machine immediately and correct the problem before continuing. Serious damage could occur if the machine is operated with a malfunction.

Mowing —Start the engine and move throttle to FAST so the engine is running at maximum speed. Move the ENABLE/DISABLE switch to ENABLE and use the LOWER MOW/RAISE lever to control the cutting units (front cutting units are timed to lower before the rear cutting units). To move forward and cut grass, press the traction pedal forward. Maintain a speed which does not result in the Reel Control Light being illuminated. Gradually increase or decrease the traction speed to ensure proper clip is maintained.

Transport—Move the ENABLE/DISABLE switch to DISABLE, lock the brake pedals together and raise the cutting units to the transport position. Be careful when driving between objects so you do not accidentally damage the machine or cutting units. Use extra care when operating the machine on slopes. Drive slowly and avoid sharp turns on slopes to prevent roll overs. The cutting units should be lowered when going downhill for steering control.

Selecting Clip Rate (Reel Speed)—The automatic clip control programmed in the machine controller requires that it be told at what height of cut the machine is being operated and whether the machine is equipped with 5- or H-blade reels. Refer to *Selecting Clip Rate (Reel Speed)*.

When the machine is being operated in such a way that it achieves the desired clip, the Reel Control light will not light. If it does light, this indicates that the traction speed is too low or too high for the machine to achieve the desired clip.

Maintenance

GREASING BEARINGS AND BUSHINGS (Fig. 22–30)

The machine has grease fittings that must be lubricated regularly with No. 2 General Purpose Lithium Base Grease. If the machine is operated under normal conditions, lubricate all bearings and bushings after every 50 hours of operation or immediately after every washing.

1. The grease fitting locations and quantities are:
Cutting unit carrier frame and pivot (2 ea.) (Fig. 22); Rear axle tie rod (2), Steering cylinder ball joints (2), (Fig. 23); Front lift cylinders (2), (Fig. 24); Front lift cylinder (1), (Fig. 25); Rear lift cylinder pivot (2), (Fig. 26); Lift arm pivot (3), (Fig. 27); Rear axle pivot (Fig. 28) Rear lift arm pivots (2) (Fig. 29) and Brake pedal shaft (1) (Fig. 30).

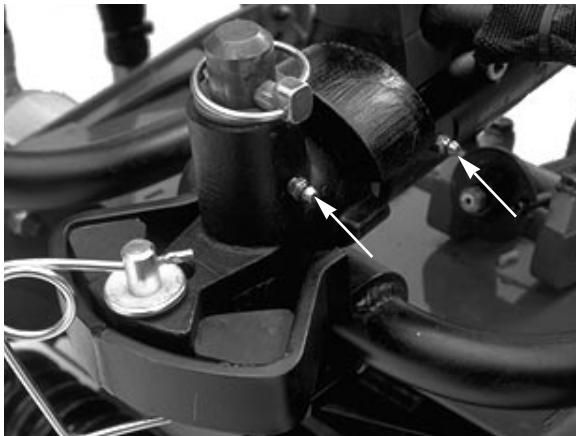

Figure 22

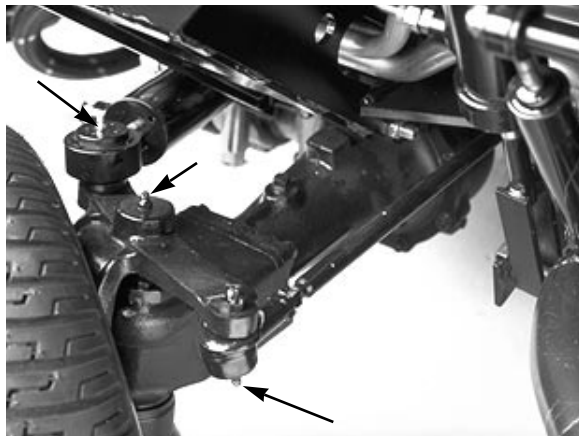

Figure 23

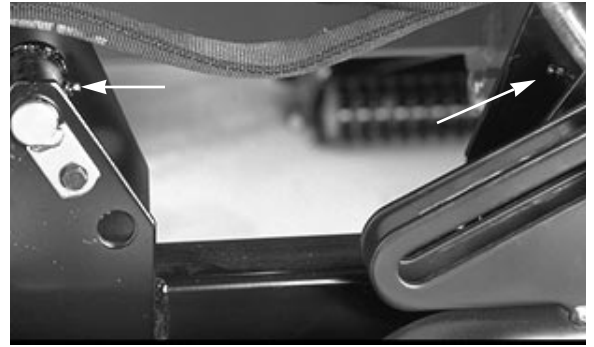

Figure 24

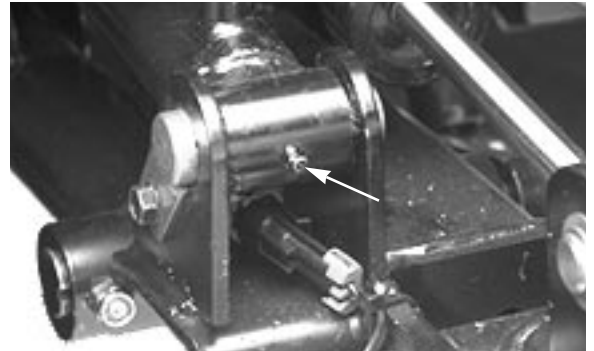

Figure 25

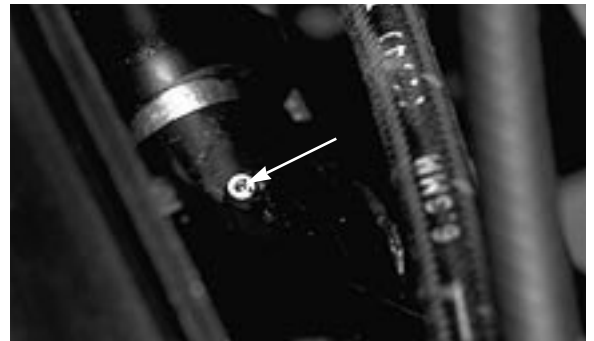

Figure 26

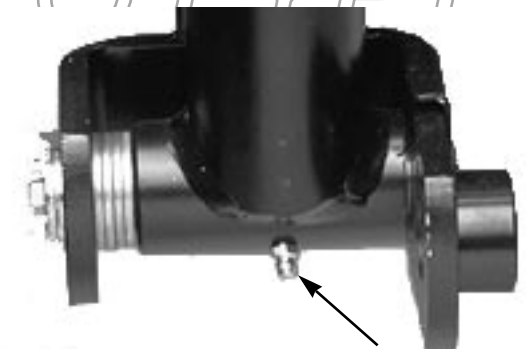

Figure 27

ROTOTYPE

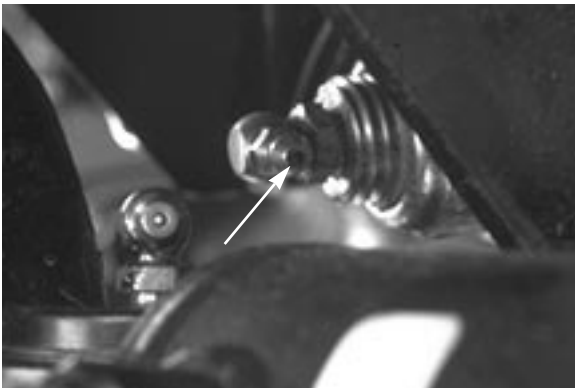

Figure 28

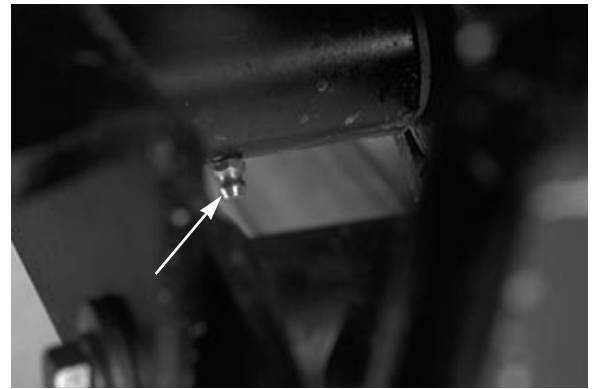

Figure 29



Figure 30

Reelmaster 6500-D, 2-Wheel Drive Quick Reference Aid
Check/Service (daily)

1. Oil level, engine
2. Oil level, hydraulic tank
3. Coolant level, radiator
4. Fuel/Water separator
5. Air filter service indicator
6. Radiator screen
7. Brake function
8. Tire pressure

Check/Service (See Operator's Manual)

9. Battery
10. Belts (fan, alternator)
11. Planetary gear drive

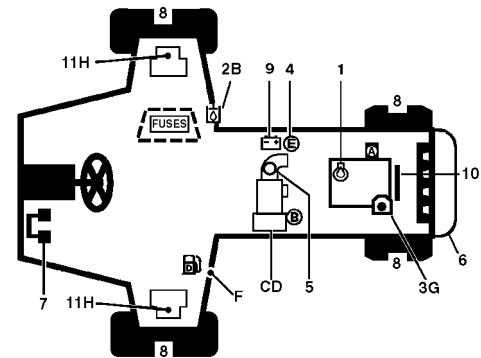

	Fluid Type	Capacity	Fluid	Filter	Filter Part No.
Engine Oil	SAE 15W-40CD	5 l	100 hours	100 hours	74-7970
Hydraulic Circuit Oil	Mobil 424	32 l	800 hours	See service indicator	94-2621
Primary Air Filter				See service indicator	93-9162
Safety Air Filter					93-9163
Fuel Filter				400 hours	76-5220
Fuel Tank	No. 2 Diesel	56 l	Drain and flush every 2 years		
Coolant	93-7213	13.25 l	Drain and flush every 2 years		
Planetary Gear Drive	SAE85W140	.44 l	800 hours		



CAUTION

Before servicing or making adjustments to the machine, stop the engine and remove the key from the switch.

GENERAL AIR CLEANER MAINTENANCE

1. Check the air cleaner body for damage which could possibly cause an air leak. Replace a damaged air cleaner body.
2. Service the air cleaner filters whenever the air cleaner indicator (Fig. 31) shows red or every 400 hours (more frequently in extreme dusty or dirty conditions). Do not overservice the air filter.
2. Be sure the cover is sealing around the air cleaner body.

SERVICING THE AIR CLEANER

1. Release the latches securing the air cleaner cover to the air cleaner body. Separate the cover from the body. Clean inside of the air cleaner cover.
2. Gently slide the primary filter (Fig. 33) out of the air cleaner body to reduce the amount of dust dislodged. Avoid knocking the filter against the air cleaner body. Do not remove the safety filter.
3. Inspect the primary filter and discard it if damaged. Do not wash or reuse a damaged filter.

IMPORTANT: Never attempt to clean a safety filter. Replace the safety filter with a new one after every three primary filter services.

Washing Method

- A. Prepare a solution of filter cleaner and water and soak the filter element about 15 minutes. Refer to directions on the filter cleaner carton for complete information.
- B. After soaking the filter for 15 minutes, rinse it with clear water. Maximum water pressure must not exceed 40 psi to prevent damage to the filter element. Rinse the filter from clean side to dirty to side.



Figure 31

1. Air cleaner indicator

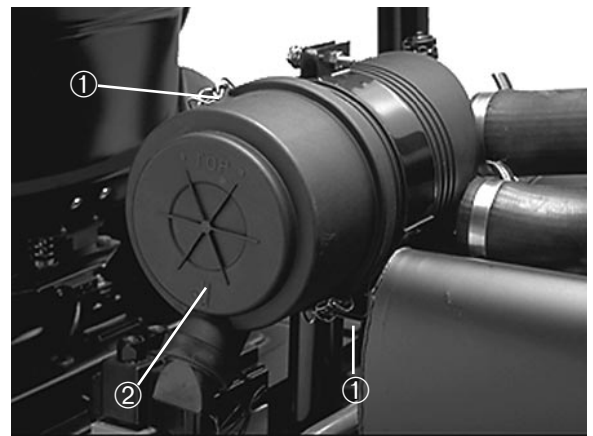

Figure 32

1. Air cleaner latches
2. Dust cup



Figure 33

1. Air cleaner primary filter

- C. Dry the filter element using warm, flowing air (71° C max), or allow element to air-dry. Do not use a light bulb to dry the filter element because damage could result.

Compressed Air Method

- A. Blow compressed air from the inside to the outside of the dry filter element. Do not exceed 689 kPa to prevent damage to the element.
 - B. Keep the air hose nozzle at least 5 cm from the filter and move the nozzle up and down while rotating the filter element. Inspect for holes and tears by looking through the filter toward a bright light.
5. Inspect the new filter for shipping damage. Check the sealing end of the filter. Do not install a damaged filter.
 6. Insert new filter into the air cleaner body. Make sure the filter is sealed properly by applying pressure to the outer rim of the filter when installing it. Do not press on the flexible center of the filter.
 7. Reinstall the cover and secure the latches. Make sure the cover is positioned with THE TOP side up.
 8. Reset the indicator (Fig. 31) if it still shows red.

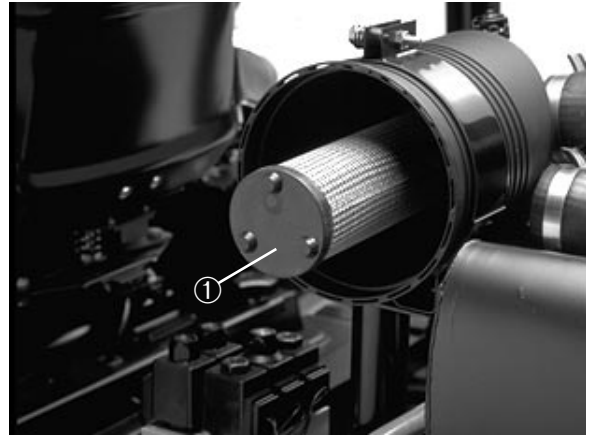

Figure 34

1. Air cleaner safety filter

ENGINE OIL AND FILTER (Fig. 35–36)

CAUTION

Before servicing or making adjustments to the machine, stop the engine and remove the key from the switch.

Change the oil and filter initially after the first 50 hours of operation; thereafter change the oil and filter every 100 hours.

1. Remove the drain plug (Fig. 35) and let the oil flow into the drain pan. When the oil stops, install the drain plug and the new plug seal, Part No. 74-7850.
2. Remove the oil filter (Fig. 36). Apply a light coat of clean oil to the new filter seal before screwing it on. **DO NOT OVERTIGHTEN.**
3. Add 15W–40 CD oil to the crankcase. Capacity is 5 l with the filter.

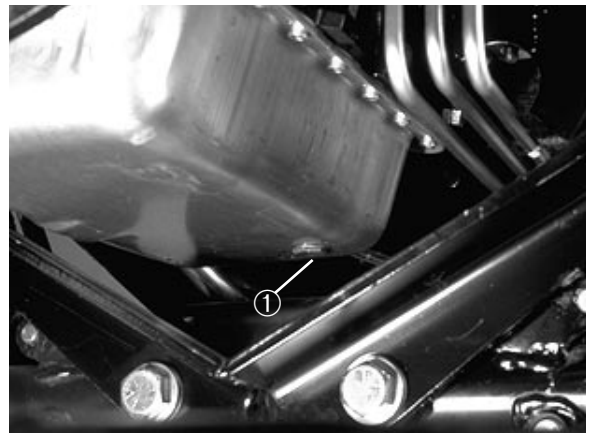

Figure 35

1. Drain plug



Figure 36

1. Oil filter

FUEL SYSTEM (Fig. 37 & 38)

Fuel Tank

Drain and clean the fuel tank every 800 hours of operation or yearly, whichever comes first. Also, drain and clean the tank if the fuel system becomes contaminated or if the machine is to be stored for an extended period. Use clean fuel to flush out the tank.

DANGER

Because diesel fuel is flammable, use caution when storing or handling it. Do not smoke while filling the fuel tank. Do not fill the fuel tank while the engine is running, hot, or when the machine is in an enclosed area. Always fill the fuel tank outside and wipe up any spilled diesel fuel before starting the engine. Store fuel in a clean, safety-approved container and keep the cap in place. Use diesel fuel for the engine only; not for any other purpose.

Fuel Lines and Connections

Check lines and connections every 400 hours or yearly, whichever comes first. Inspect for deterioration, damage, or loose connections.

Draining The Fuel Filter/Water Separator

Drain water or other contaminants from the fuel filter/water separator daily.

1. Place a clean container under the fuel filter.
2. Loosen the drain screw on bottom of the fuel filter and press the primer plunger until only fuel is evident draining into container.
3. Tighten the drain screw.

Changing The Fuel Filter

Replace the fuel filter if the fuel flow becomes restricted, after every 400 hours of operation or annually, whichever comes first.

1. Loosen the bolt and unscrew the bottom filter cap from the filter assembly. Remove the cap, gaskets, o-ring and filter from the assembly.



Figure 37

1. Fuel tank drain

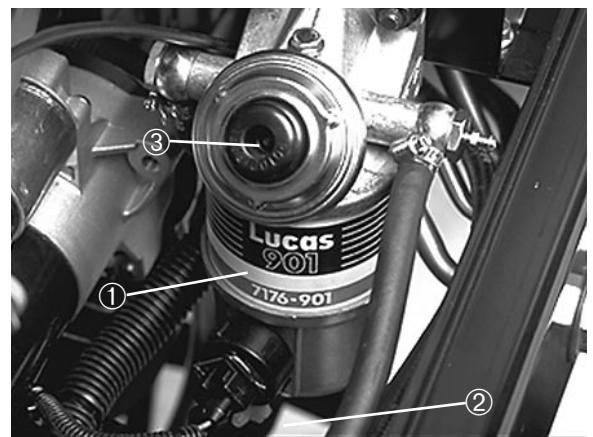

Figure 38

1. Fuel filter/water separator
2. Drain screw
3. Primer plunger

Note the position of the gaskets and o-ring when disassembling from the filter.

2. Install a new filter, gaskets, o-ring with the filter assembly cap.
3. Prime the fuel system, refer to *Priming The Fuel System*.

ENGINE COOLING SYSTEM (Fig. 39–40)

1. **Removing Debris**—Remove debris from the rear screen, oil cooler and radiator daily. Clean more frequently in dirty conditions.

IMPORTANT: Never spray water onto a hot engine as damage to the engine may occur.

- A. Turn the engine off, release the hood latch and raise the hood. Clean the engine area thoroughly of all debris. Close the hood.
- B. Unlatch and remove rear screen (Fig. 39). Clean screen thoroughly.
- C. Unscrew knobs and pivot the oil cooler rearward. Clean both sides of the oil cooler and radiator area thoroughly with compressed air. Do not use water. Open the hood and blow debris out toward back of the machine. Pivot the oil cooler back into position and tighten knobs.

Note: Fan shroud may be easily unbolted from the machine to simplify cleaning.

- D. Install rear screen and secure the latches.

Note: Do not use water to clean the engine, as damage may occur.

2. **Maintaining the Cooling System**—Capacity of the system is 13.25 l. Always protect the cooling system with a 50/50 solution of water and Peugeot-recommended anti-freeze (Part No. 93-7213). **DO NOT USE WATER ONLY IN THE COOLING SYSTEM.**

- A. After every 100 operating hours, inspect and tighten hose connections. Replace any deteriorated hoses.
- B. After every 2 years, drain and flush the cooling system. Add anti-freeze (refer to *Check The Cooling System*).

ENGINE FAN BELT (Fig. 41)

Check condition and tension of fan belt after every 100 hours of



Figure 39

1. Rear screen

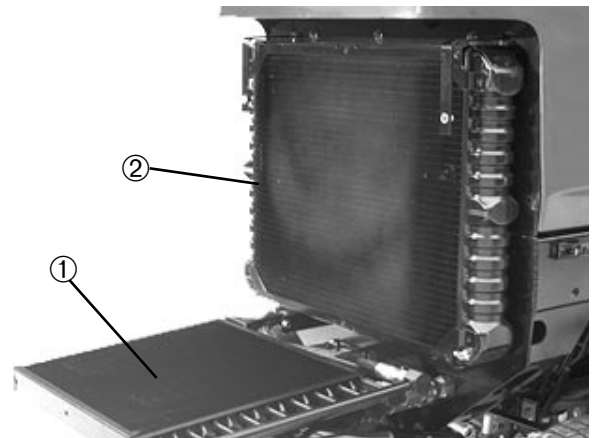

Figure 40

1. Oil cooler
2. Radiator

operation. Replace belt as required.

1. Proper tension will allow 0.64 cm deflection on the belt mid-way between the pulleys, when pressed firmly with thumb.
2. If deflection exceeds 0.64, loosen the alternator mounting bolts. Adjust the alternator belt's tension by adjusting the tension screw. Check the deflection of belt again to assure its tension is correct.

CHANGING HYDRAULIC FLUID (Fig. 42)

Change hydraulic fluid after every 800 operating hours, in normal conditions. If the fluid becomes contaminated, contact your local TORO distributor because the system must be flushed. Contaminated fluid looks milky or black when compared to clean the oil.

1. Turn the engine off and raise the hood.
2. Remove the drain plug from bottom of the reservoir and let hydraulic fluid flow into the drain pan. Reinstall and tighten the plug when hydraulic fluid stops draining.
3. Fill the reservoir with approximately 32 l of hydraulic fluid. Refer to *Checking Hydraulic Fluid*.

IMPORTANT: Use only hydraulic fluids specified. Other fluids could cause system damage.

4. Install the reservoir cap. Start the engine and use all hydraulic controls to distribute hydraulic fluid throughout the system. Also check for leaks. Then stop the engine.
5. Check the level of fluid and add enough to raise the level to the FULL mark on the dipstick. **DO NOT OVER FILL.**

REPLACING THE HYDRAULIC FILTER (Fig. 43)

The hydraulic system filter head is equipped with a service interval indicator. With the engine running, view the indicator. It should be in the GREEN zone. When the indicator is in the RED zone, the filter element should be changed.

Use the Toro replacement filter (Part No. 94-2621).

IMPORTANT: Use of any other filter may void the warranty on

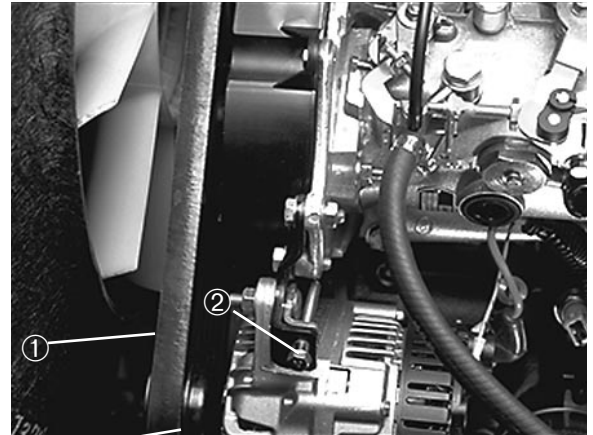

Figure 41

1. Fan belt
2. Adjusting screw



Figure 42

1. Hydraulic reservoir

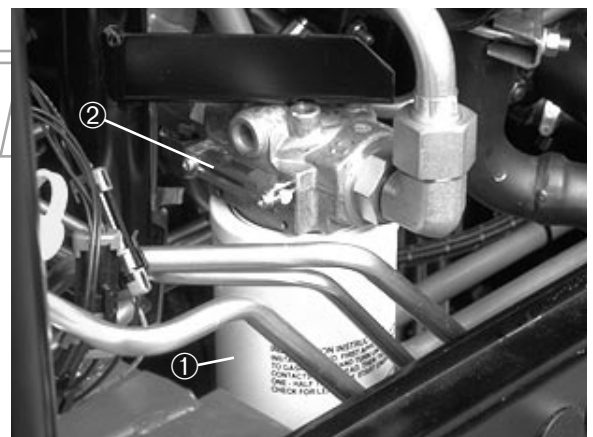

Figure 43

1. Hydraulic filter
2. Service interval indicator

some components.

1. Position the machine on a level surface, lower the cutting units, stop the engine, engage the parking brakes and remove the key from the ignition switch.
2. Clean the area around the filter mounting area. Place the drain pan under the filter and remove the filter.
3. Lubricate the new filter gasket and fill the filter with hydraulic fluid.
4. Assure the filter mounting area is clean. Screw the filter on until gasket contacts mounting plate. Then tighten the filter one-half turn.
5. Start the engine and let it run for about two minutes to purge air from the system. Stop the engine and check for leaks.

CHECKING HYDRAULIC LINES AND HOSES

Inspect hydraulic lines and hoses daily for leaks, kinked lines, loose mounting supports, wear, loose fittings, weather deterioration and chemical deterioration. Make all necessary repairs before operating.

ADJUSTING THE TRACTION DRIVE FOR NEUTRAL (Fig. 44)

The machine must not creep when the traction pedal is released. If it does creep, an adjustment is required.

1. Park the machine on a level surface, shut the engine off and lower cutting units to the floor. Depress **only** the right brake pedal and engage the parking brake.
2. Jack up the left side of the machine until front tire is off the shop floor. Support the machine with the jack stands to prevent it from falling accidentally.

Note: On 4-wheel drive models, the left rear tire must also be off the shop floor.

3. Start the engine and allow it to run at low idle.
4. Adjust the jam nuts on the pump rod end to move the pump control tube forward to eliminate forward creep or rearward to eliminate rearward creep.

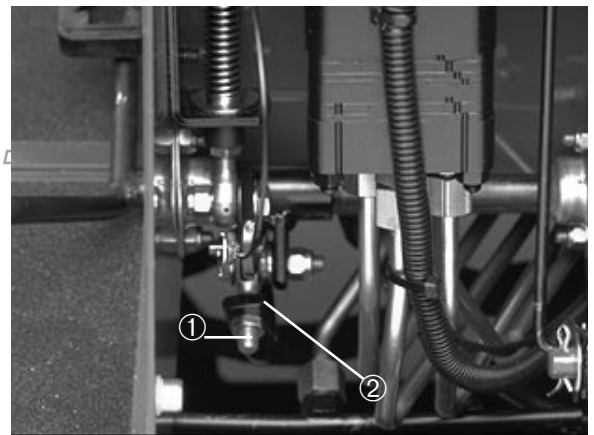

Figure 44

1. Pump rod
2. Pump control tube

5. After wheel rotation ceases, tighten the jam nuts to secure adjustment.
6. Stop the engine and release the right brake. Remove the jack stands and lower the machine to the shop floor. Test drive the machine to make sure it does not creep.

ADJUSTING THE CUTTING UNIT LIFT RATE (Fig. 45)

The cutting unit lift circuit is equipped with an adjustable valve to ensure the front cutting units raise and lower evenly. Adjust the cutting units as follows:

1. Locate the valve under the seat.
2. Loosen the setscrew on the valve. Rotate the valve clockwise to slow down drop rate of the front outside cutting units.
3. Verify lift rate adjustment by raising and lowering the cutting units several times. Readjust as required.
4. After desired lift rate is attained, tighten the set screw to lock adjustment.

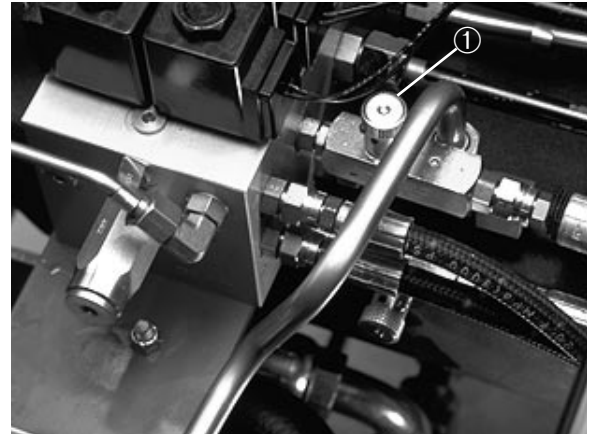

Figure 45

1. Cutting unit adjustment valve

ADJUSTING THE SERVICE BRAKES (Fig. 46)

Adjust the service brakes when there is more than 2.5 cm of “free travel” of the brake pedal, or when the brakes do not work effectively. Free travel is the distance the brake pedal moves before braking resistance is felt.

1. Disengage the locking pin from the brake pedals so both pedals work independently of each other.
2. To reduce free travel of brake pedals, tighten the brakes—loosen the front nut on the threaded end of the brake cable. Then tighten the rear nut to move the cable backward until the brake pedals have 1.2–2.5 cm of free travel. Tighten the front nuts after the brakes are adjusted correctly.

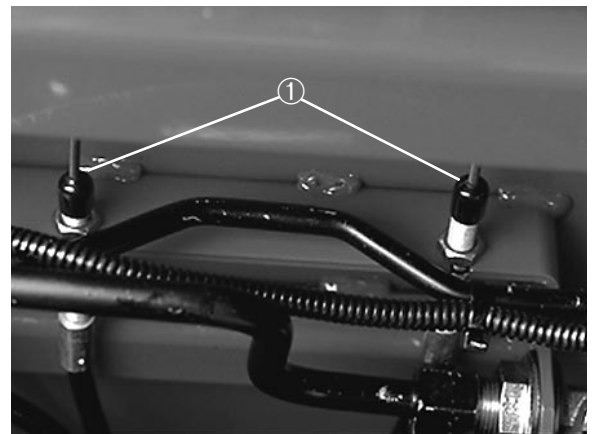

Figure 46

1. Brake cables

CHANGING PLANETARY GEAR DRIVE OIL (Fig. 47)

Change the oil initially after 200 hours operation and every 800 hours, or yearly. Use high-quality SAE 85W-140 wt. gear lubrica-

tion as replacement.

1. With the machine on a level surface, position the wheel so the check/drain plug is at its lowest position.
2. Place the drain pan under the hub, remove the plug and allow the oil to drain.
3. When all oil has been drained, position the wheel so the plug hole is at three or nine o'clock position.
4. Place the drain pan under the brake hub on other side of the wheel.
5. Remove the plug from the bottom of the hub and allow the oil to drain.
6. When all oil has drained, re-install the plug in the hub.
7. Add high-quality SAE 85W-140 wt. gear lubrication to bring the level up to the bottom of the hole and install the plug.
8. Repeat this procedure on the opposite gear assembly.

REAR WHEEL TOE-IN (Fig. 50)

After every 800 operating hours or annually, check rear wheel toe-in.

1. Measure center-to-center distance (at axle height) at front and rear of steering tires. Front measurement must be 1/4 in. less than rear measurement.
2. To adjust, loosen clamps at both ends of tie rods.
3. Rotate tie rod to move front of tire inward or outward.
4. Tighten tie rod clamps when adjustment is correct.

BACKLAPPING

CAUTION

Reels may stall while backlapping. do not attempt to restart the reels by hand or touch the reels while backlapping. Stop the engine and turn the Height-of-Cut knob one position toward "A".



Figure 47

1. Drain/Check plug

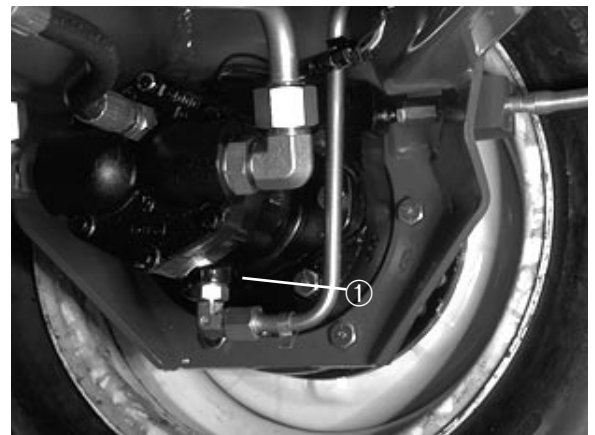
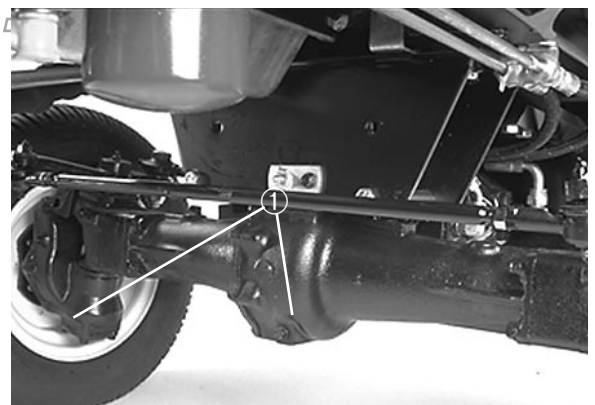

Figure 48

1. Drain plug location

Figure 49



(Model 03801 only)

1. Drain plugs (3)

Note: When backlapping, the front units all operate together, and the rear units operate together.

1. Position the machine on a level surface, lower the cutting units, stop the engine, engage the parking brake, and move the Enable/Disable switch to the Disable position.
2. Unlock and raise the seat to expose the controls.
3. Open the control cover and turn the height-of-cut selection knob to position "P".

Note: Backlapping speed may be increased by moving the height-of-cut selection knob toward to "A". Each position will increase speed 60 rpm. After changing selector, wait 30 seconds for the system to respond to the new speed target.

4. Make initial reel-to-bedknife adjustments appropriate for backlapping on all cutting units that are to be backlapped.
5. Start the engine and run it at idle speed.

DANGER: To avoid personal injury, never place your hands or feet in the reel area while the engine is running. Changing engine speed while backlapping may cause the reels to stall. Never change engine speed while backlapping. Only backlap at idle engine speed. Never attempt to turn reels with your hand or foot while the engine is running.

6. Select either the front or rear on the backlap switch to determine whether front or rear reels will be backlapped.

DANGER: To avoid personal injury, be certain that you are clear of the cutting units before proceeding.

7. Move the Enable/Disable switch to the Enable position. Move the Lower Mow/Lift control forward to start back-lapping operation on designated reels.
8. Apply lapping compound with the long-handle brush supplied with the machine. Never use a short-handle brush.
9. If the reels stall or become erratic while backlapping, the reel control light will begin to blink and the reels will turn off. If this occurs, turn the height-of-cut. selection knob one position closer to "A". Then, toggle the Enable/Disable switch to the Disable position followed by the Enable position. To resume backlapping, move the Lower Mow/Lift control lever forward.



Figure 50

1. Tie rod clamps

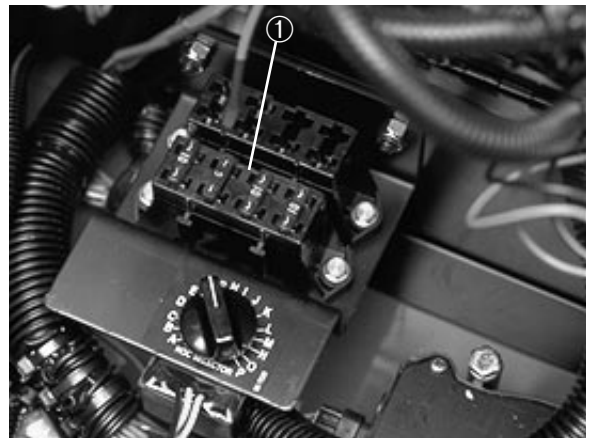

Figure 51

1. Fuses

IMPORTANT USE CORRECT FUSES. WRONG FUSES CAN CAUSE DAMAGE TO CONTROLLER AND VOID WARRANTY.	
OPTIONAL LIGHTS	CONTROLLER POWER (1)
10A	10A
CONTROLLER POWER (2)	IGNITION SWITCH
15A	5A
LEAK DETECTOR	CONTROLLER POWER
5A	10A
OPEN	CONTROLLER POWER
	10A

93-7596

10. To make an adjustment to the cutting units while backlapping, turn the reels OFF by moving the Lower Mow/Raise lever rearward; move the Enable/Disable switch to Disable and turn the engine OFF. After adjustments have been completed, repeat steps 5–9.
11. Repeat this procedure for all cutting units to be backlapped.
12. When you've completed the backlap operation, return the backlap switch to OFF, lower the seat and wash all lapping compound off the cutting units. Adjust the cutting unit reel to the bedknife as needed.

IMPORTANT: If the backlap switch is not returned to the OFF position after backlapping, the cutting units will not raise or function properly.

Preparation for Seasonal Storage

Traction Unit

1. Thoroughly clean the traction unit, cutting units and the engine.
2. Check the tire pressure. Inflate all tires to 103–138 kPa.
3. Check all fasteners for looseness; tighten as necessary.
4. Grease or oil all grease fittings and pivot points. Wipe up any excess lubricant.
5. Lightly sand and use touch-up paint on painted areas that are scratched, chipped, or rusted. Repair any dents in the metal body.
6. Service the battery and cables as follows:
 - a. Remove the battery terminals from the battery posts.
 - b. Clean the battery, terminals, and posts with a wire brush and baking soda solution.
 - c. Coat the cable terminals and battery posts with Grafo 112X skin-over grease (Toro Part No. 505-47) or petroleum jelly to prevent corrosion.
 - d. Slowly recharge the battery every 60 days for 24 hours to prevent lead sulfation of the battery.

Engine

1. Drain the engine oil from the oil pan and replace the drain plug.
2. Remove and discard the oil filter. Install a new oil filter.
3. Refill the oil pan with 5 l of SAE 15W-40 CD motor oil.
4. Start the engine and run at idle speed for two minutes.
5. Stop the engine.
6. Flush the fuel tank with fresh, clean diesel fuel.
7. Secure all fuel system fittings.
8. Thoroughly clean and service the air cleaner assembly.
9. Seal the air cleaner inlet and the exhaust outlet with weatherproof tape.
10. Check anti freeze protection and add a 50/50 solution of water and Peugeot recommended anti freeze, Part No. 93-7213, as needed for the expected minimum temperature in your area.

PROTOTYPE

PROTOTYPE



PROTOTYPE