

EVOLUTION® Series Add-On: EVO-WS Weather Sensor

Introduction

Congratulations on purchasing Toro's new EVOLUTION Series Controller with the EVO-WS Weather Sensor Add-On. With the Weather Sensor Add-On, you will quickly realize savings in both time and money while keeping your garden healthy and beautiful.

The EVO-WS Wireless Weather Sensor system is designed exclusively for your Toro EVOLUTION Series Controller to continuously monitor and adjust automatic watering to suit current watering needs.

The Wireless Sensor system consists of a remote Weather Sensor. The sensor detects current sunlight level, temperature and rainfall, then transmits this information wirelessly to the Smart Connect™ (offered separately) device plugged into the EVOLUTION Series Controller. The controller then adjusts the

running time to provide the optimum amount of water required for the next watering day.

To familiarize yourself with EVO-WS Weather Sensor system, please take a few moments to read through this guide in its entirety.

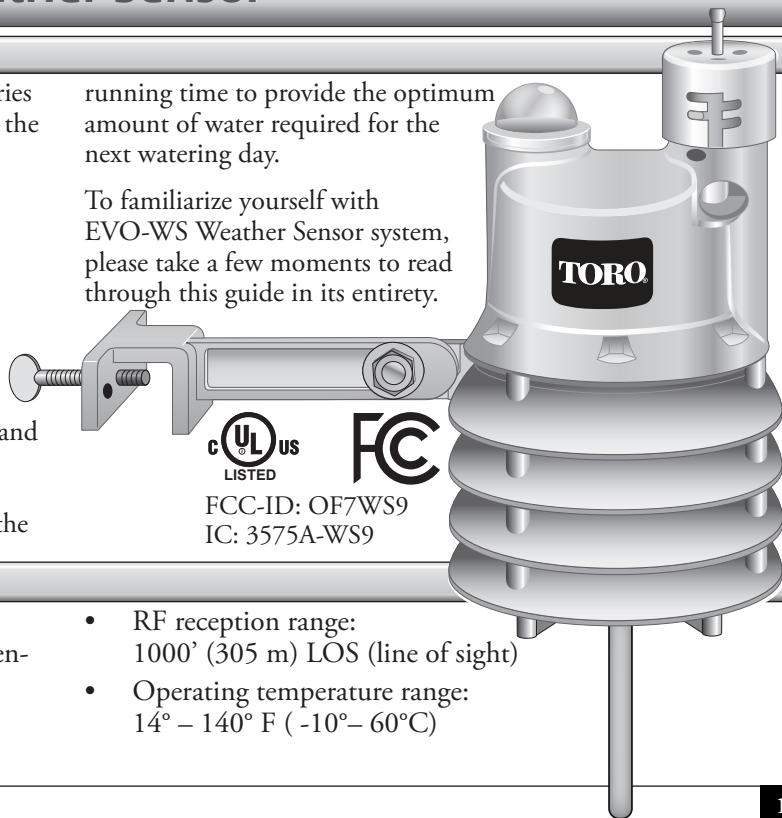

Specifications

- Dimensions:
2.75" (7 cm) W x 7" (17,8 cm) H (over 2" [5 cm] antenna) x 6.25" (15,9 cm) D (over 4" [10,2 cm] mounting bracket)
- 9V Alkaline battery (included)
- RF reception range:
1000' (305 m) LOS (line of sight)
- Operating temperature range:
14° – 140° F (-10° – 60°C)

Table of Contents

Specifications	1	Freeze Off	10
Weather Sensor Overview	3	Dryout Days	10
Installation	4	Water Adjust	10
Smart Connect®	4	Update Time	11
The SD Card Explained	4	Average % Days	11
Adding the Sensor to the Controller	4	My Location	11
Adjusting the Rain Sensor Threshold	7	Signal Strength	11
Weather Sensor	7	Battery Level	11
Basic Operation	9	Battery Replacement	12
Menu Navigation	9	Review	13
Getting to the Sensors Menu	9	Resetting to Factory Defaults	13
Weather Sensor Menu	10	Wireless Communication Problems	13
Current Adjust	10	Toro Warranty and Support	14
Temperature	10	Installation Notes	15
Rain Status	10		

Weather Sensor Overview

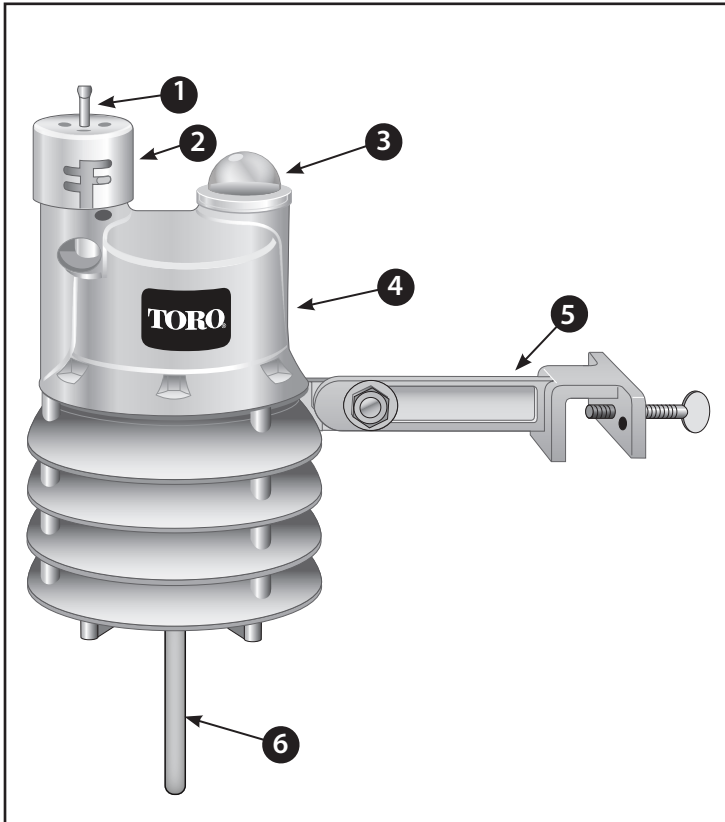

1. Rain Sensor Test Pin

Pressing the test pin simulates operation of the Rain Sensor by transmitting a signal to the Smart Pod.

2. Rain Sensor Adjustment Cap

The Rain Sensor sensitivity is adjustable to suspend watering at 1/8", 1/4", 1/2" and 3/4" (3 mm, 6 mm, 12 mm and 19 mm) of accumulated rainfall.

3. Solar Collector

Solar radiation and temperature are used by the Smart Pod to calculate and adjust watering to suit current weather conditions.

4. Battery Compartment

A 9V Alkaline battery (installed) can provide Weather Sensor operation up to five years.

 See battery service information on page 9 for additional information.

5. QuickClip™ Mounting Bracket

The QuickClip bracket design enables the Weather Sensor to be easily installed and aligned.

6. Antenna

Installation

EVOLUTION® Smart Connect®

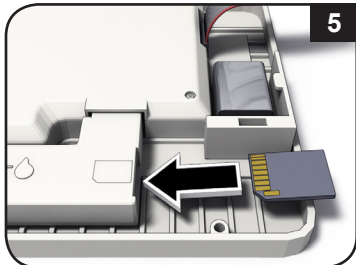
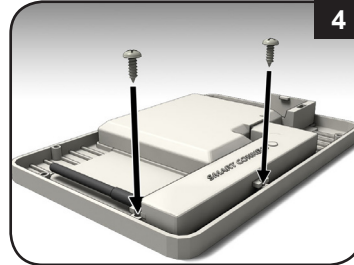
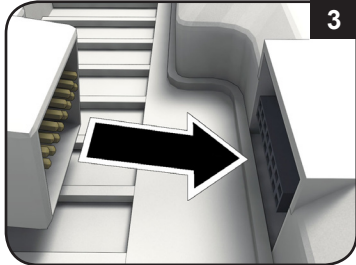
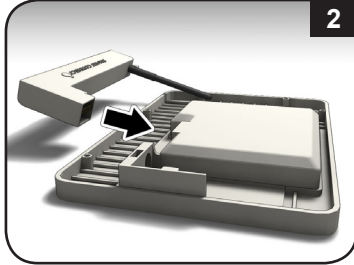
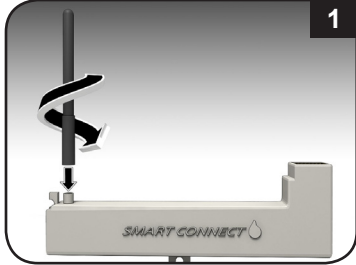

SD Card Explained





The supplied SD card contains forty years of weather data for all latitudes, longitudes, and zip codes in North America. When the weather sensor's location is entered in the controller (page 6), historical weather data is loaded into the controller.

In the event your controller loses connectivity to the weather sensor, the controller will use the the historical weather data to determine the irrigation run time until connectivity is restored.

Adding the Sensor to the Controller

For the EVOLUTION® controller to communicate with the weather sensor, the sensor (with its unique ID) must be "added" to the controller.

(For assistance with menu navigation, please see the "Menu Navigation" section on page 9.)

1. Press  **ADVANCED** then .
2.  to **ADD/REMOVE DEVICE**.  to confirm.



3.  to WEATHER.  to ADD.  to confirm.

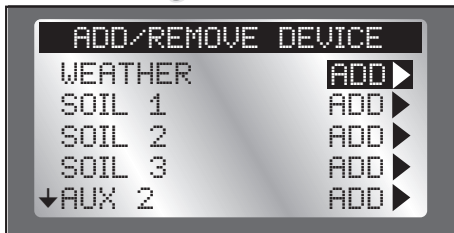

4. The EVOLUTION® controller waits for the identification signal from the weather sensor.



5. Activate the sensor.



The EVO-WS Weather Sensor is shipped with the battery circuit deactivated. *It is necessary to activate the sensor prior to installation.*

To activate the sensor:

For new sensors, press and hold the Test Pin for 10-15 seconds. A red LED, viewable from the lower vent area, will illuminate twice after 10 seconds (if not already active).

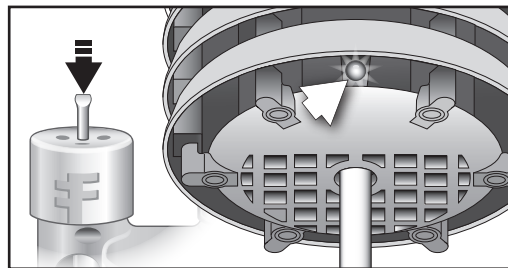

If the sensor is already installed, there are two ways to establish communication:

- Go to the sensor and press and release the test pin for 15 seconds
- OR -
- Simply wait 30 minutes for the sensor to communicate with the controller.

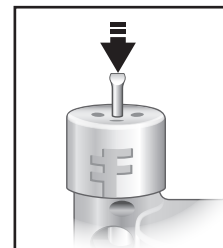

Return to the controller.

6. The controller should detect the sensor. Confirm that the device ID detected matches the sensor's actual ID.

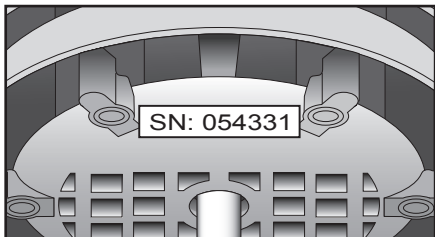
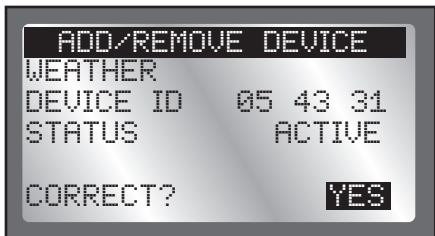







If it does match, press  and continue to add the sensor. If it does *not* match, change to NO, press , and repeat steps 3-6.

7. The next step is to enter the location information. It is possible to enter either by zip code or Latitude and Longitude coordinates (available from Google Maps®).



To adjust TYPE, press  to move to ZIP CODE. Press  to select LONG/LAT or ZIP CODE.

8. Press . Adjust the Zip Code or Latitude and Longitude values with the  and  buttons. Use  and  to switch between number fields.
9. When done, move to CONTINUE. Press . After a moment, the screen returns to the ADD/REMOVE DEVICE screen.

The sensor is now added. ***To actually control irrigation, it must be added to a schedule*** (see page 9).

Adjusting the Rain Sensor Threshold

The Weather Sensor is preset to suspend watering at 1/4" (6 mm) of accumulated rainfall. Three alternate settings of 1/8" (3 mm), 1/2" (12 mm) and 3/4" (19 mm) are provided. Prior to installing the Weather Sensor, adjust the threshold to the preferred setting as required.

 Increasing the threshold setting results in extending the length of timer required for the sensor to shut off or postpone watering during rain, as well as extending the dry-out period before scheduled watering will resume. In areas where heavy fog or mist is common, the 1/8" (3 mm) setting may not provide accurate rain detection, and is not recommended.

1. Turn the cap slightly, releasing it from the two retaining pins.
2. Adjust the cap to engage the pins at the preferred slot setting.

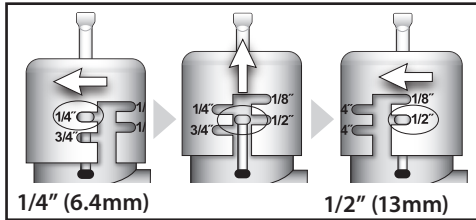

The Weather Sensor

 **Important:** The Weather Sensor must have full exposure to sun, wind and rain, and must not be installed inside a rain gutter, or in any location where immersion, runoff, or contact with irrigation spray will occur. Avoid installation near a heat source, such as a heater vent or chimney. Also avoid installation near any large metal structure or high current-draw equipment that may generate signal interference. Ensure the antenna wire hangs unobstructed below the Weather Sensor.

 The communication range of the Wireless Weather Sensor system is 1000' (305 m) LOS (line of sight). Some loss of range can be expected due to interference from obstacles in the signal path. Test the signal reception from the proposed installation site prior to mounting the Weather Sensor, as described in the following procedure.





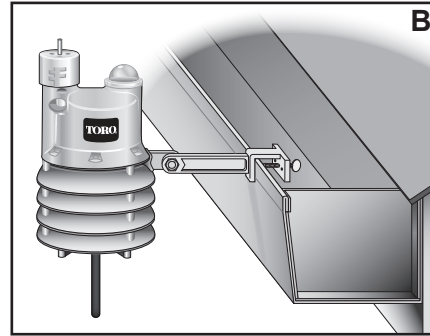
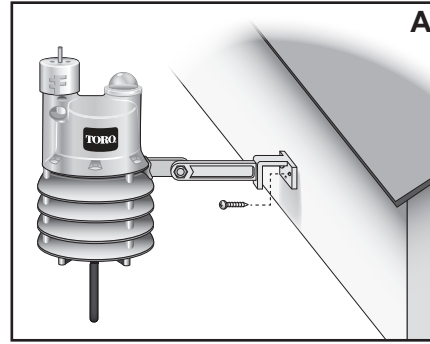

1. Start a manual watering operation for a zone that can be seen from the proposed Weather Sensor location. Press and hold the Rain Sensor test pin to send a signal to the Smart Connect. If the signal is received, watering should shut off within a short time. If not, repeat the test from a slightly different location, until communication is established.

2. (A) For rain gutter installation: back the bracket thumbscrew out to clear the rain gutter edge. Holding the Weather Sensor in position, tighten the thumbscrew securely.
(B) For solid structure installation: remove the thumbscrew and secure the bracket using the provided stainless screws (or other appropriate stainless fasteners).
3. With the mounting bracket securely fastened, check the vertical alignment of the Weather Sensor. To adjust, loosen the phillips screw at the bracket joint, adjust to vertical, then tighten the screw securely.







Basic Operation

Menu Navigation



- Use  or  to navigate the menu commands.
- To change a value, press  or  to move to the desired field, then press  and  to adjust the value.
- Remember to press  to input the desired value.

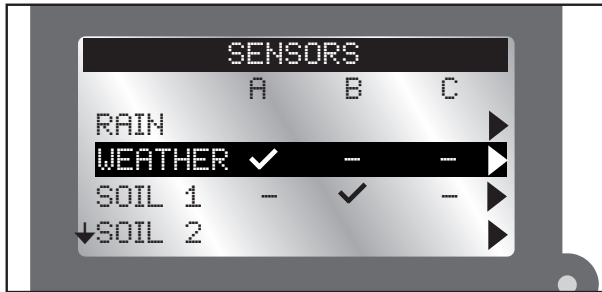

Getting to the Sensors Menu

1. Press  **ADVANCED** then .
 2. Press  to **SENSORS**. Press .
- The Sensors screen appears.



3. To add a sensor to a schedule:

Press  or  to select the desired Schedule (A, B, or C).

Press  or  to make the sensor active for the selected schedule.

- ✓: sensor is active.
- : sensor is inactive.

 In the screen above, a weather sensor is assigned to schedule A and a soil sensor to schedule B.

4. To access the settings for the Weather Sensor, press  to **WEATHER** then press  four times. The WS Sensor menu appears.

Weather Sensor Menu

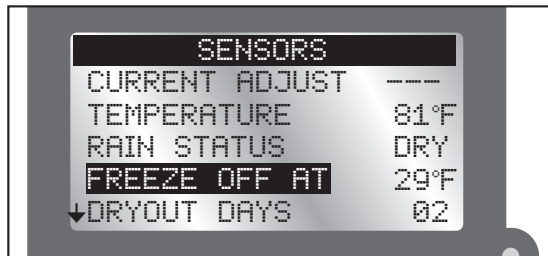

Current Adjust

The percentage that the weather sensor is going to adjust the irrigation runtime. Possible values range between OFF and +150, though realistically, values will display between $\pm 35\%$. For example, if the evapotranspiration (ET) historical data calls for a hot season, but the week has in fact been cloudy, the “Current Adjust” might show “-20%” to reflect the decreased runtime. It can also display OFF.

Temperature



Displays the current temperature at the sensor location. Temperature unit (Celsius or Fahrenheit) can be changed in the controller preferences settings (see the EVOLUTION® user manual).

Rain Status

Displays the state of the rain sensor: DRY or WET.

Freeze Off

The temperature at which irrigation will be turned off due to cold temperatures. Selections range from 29°-45°F in 2 degree increments.



1. Press  or  to raise or lower the temperature value.
2. Press  to input the value.

 It is possible to disable the Freeze Off feature. Lowering the temperature past 29°F will show OFF.

Press  to input the value.



Dryout Days



After a rain, it is not always necessary to resume irrigation right away. Setting a Dryout Days period, from zero to 14 days, delays the automatic resumption of irrigation.

1. Press  or  to increase or decrease the number of days to “dryout”.
2. Press  to input the value.

Water Adjust

Water Adjust allows the runtime of all stations in all schedules to be adjusted by a maximum of $\pm 35\%$. So, for example, if the programmed runtime for station 1 is 10 minutes, setting a Water Adjust of +35% would adjust that run time to 13 minutes, 30 seconds. This is useful for seasonal changes.

1. Press  or  to increase or decrease the percentage of irrigation runtime.
2. Press  to input the value.





 It is possible to disable the Water Adjust feature. Lowering the number below -35% or above +35% will show **OFF**. (The sensor will continue to operate as a rain and temperature sensor.)
Press  the to input the value.

Low Limit

This feature allows the user to set the lowest level that the sensor will allow the controller to adjust. The default is **OFF** but can be adjusted to -99% to -50%. Meaning, if the sensor was going to make a -90% adjustment, but the Low Limit was set to -70, the controller would water at -70%.



Update Time

This is the time at which the sensor will update the controller with new ET data. If irrigation were to commence at 6am, for example, it might be advantageous to have ET data sent to the controller at 5:45am to optimize watering runtimes.

1. Press  or  to adjust the hour, minute, and AM/PM fields.
2. Press  or  to switch from one field to another.
3. Press  to input the value.

Average % Days





This is the previous number of days from which the sensor will use to generate an average runtime value. This is done to minimize the impact of unseasonably cold or hot days. Values range from 1-7 (days).

1. Press  or  to change the number of days.
2. Press  to input the value.

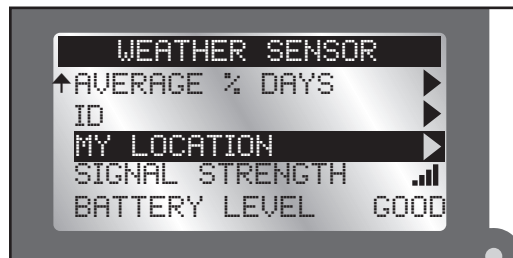
My Location

Setting the My Location is necessary for ET data to work. It is possible to set the location by either U.S. ZIP Code or by Latitude and Longitude. (See Step 7 illustration, page 6.)



1. To adjust **TYPE**, press  to move to **ZIP CODE**. Press  to select **LONG/LAT** or **ZIP CODE**.
2. Press . Adjust Zip Code or Latitude and Longitude values with the  and  buttons.

Use  and  to switch between number fields.

- When done, move to **CONTINUE**. Press .
After a moment, the screen should display **SUCCESS**.

Signal Strength

Indicates signal strength as a series of bars (▬▬▬).

Battery Level

Displays the charge level of the battery in the weather sensor.
(See above illustration.)

Battery

Under normal operating conditions, the Weather Sensor battery can last up to five years. A weak battery condition in the sensor is indicated on the EVOLUTION controller: the red LED will flash and you will be prompted to check the Alerts screen. A weak battery can result in loss of communication with the sensor.

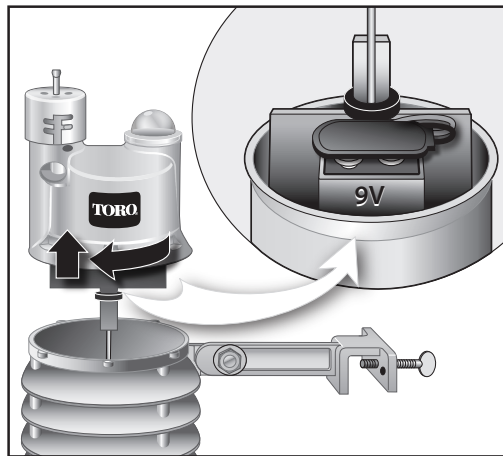





To replace the battery:



- The battery is stored in the upper half of the sensor housing. To access the battery, release and remove the upper housing by twisting it clockwise.
- Disconnect the battery wire clip. Remove and replace the used battery with a fresh 9V Alkaline battery. Reconnect the battery wire clip.

- To reassemble the sensor housing, thread the antenna wire through the lower housing, exiting the center hole in the bottom grid.
- Mate the two halves squarely, aligning the translucent dome above the mounting bracket.
- Turn the upper housing counterclockwise to securely engage the lower housing.

To clear a weak battery alert condition

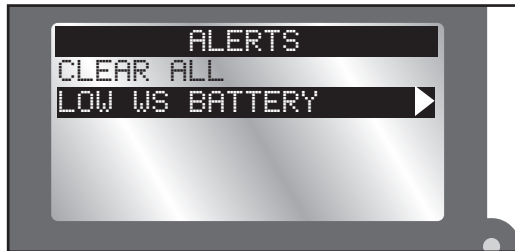
- At the controller, press .
- On **ALERTS**, press .
- On the Alerts screen, press  to move to the **LOW WS BATTERY** alert. Press .





- You will be prompted to **CLEAR ALERT?** Press  to change to **YES**. Press .



Review Screen

The Review screen allows operators to review settings for the various sensors added to the controller.

- Press the Review button.
- Press  to the **WEATHER SENSOR**. Press .

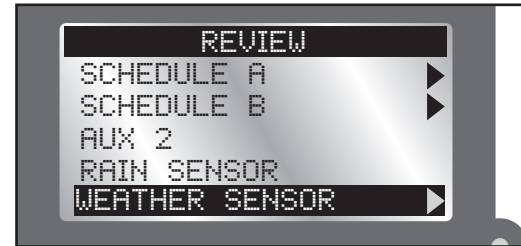

- Use  to scroll through the various sensor settings.

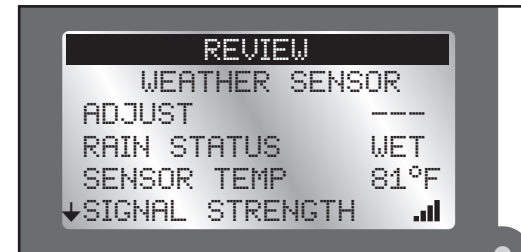

Resetting to Factory Defaults

 **Resetting to Factory Defaults clears ALL SENSOR SETTINGS and ALL ADDED IDs.**

1. Go to the Sensors screen (page 10) and scroll down to **SMART CONNECT**. Press .

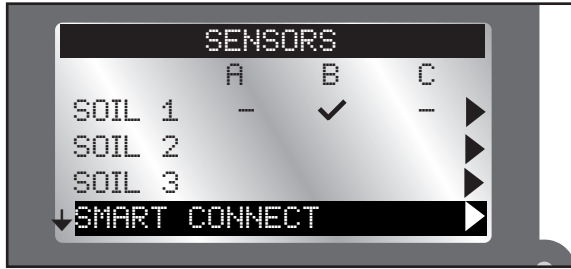

2. Change the value to **YES** and press .

Wireless Communication Problems

The effective range of the EVO-WS Weather Sensor is 1,000 feet. That range can be impacted by walls and/or electrical appliances that cause radio interference.

If you experience wireless communication problems, try the following:

- Install the sensor as close to the controller location as possible. If the signal strength is not good in one location, try another location nearby. Sometimes moving the sensor only a few feet can greatly improve signal strength.

Toro Support

Toro Commitment to Quality

Toro is committed to developing and producing the highest quality, best performing, most dependable products on the market. Because your satisfaction is our first priority, we have provided the Toro Helpline to assist you with any questions or problems that may arise. If for some reason you are not satisfied with your purchase or have questions, please contact us toll free at 1-877-345-8676.

Warranty

The Toro Company and its affiliate, Toro Warranty Company, pursuant to an agreement between them, jointly warrants, to the owner, against defects in material and workmanship for a period of five years from the date of purchase. Neither The Toro Company nor Toro Warranty Company is liable for failure of products not manufactured by them, even though such products may be sold or used in conjunction with Toro products. During such warranty period, we will repair or replace, at our option, any part found to be defective. Return the defective part to the place of purchase. Our liability is limited solely to the replacement or repair of defective parts. There are no other express warranties. This warranty does not apply where equipment is used, or installation is performed, in any manner contrary to Toro's specifications and instructions, nor where equipment is altered or modified. Neither The Toro Company nor Toro Warranty Company is liable for indirect, incidental or consequential damages in connection with the use of equipment, including but not limited to: vegetation loss, the cost of substitute equipment or services required during periods of malfunction or resulting non-use, property damage or personal injury resulting from installer's negligence.

Some states do not allow the exclusion or limitation of incidental or consequential damages, so the above limitation or exclusion may not apply to you. All implied warranties, including those of merchantability and fitness for use, are limited to the duration of this express warranty. Some states do

not allow limitations of how long an implied warranty lasts, so the above limitation may not apply to you. This warranty gives you specific legal rights and you may have other rights which vary from state to state.

Australian Warranty Statement

This product comes with a manufacturer's guarantee against defects in material and workmanship when used for its intended purpose. Our obligation under this guarantee is limited to the repair or replacement of the product at our discretion for the period stated. In the event of a claim, you must immediately cease using the product and return the product, together with your proof of purchase and an explanation of the fault to the store you purchased it from. All costs associated with the return of the product are the purchasers' responsibility. To process the warranty, the retailer must contact Toro Australia via their representative or the phone number listed below.

Our goods come with guarantees that cannot be excluded under the Australian Consumer Law. You are entitled to a replacement or refund for a major failure and for compensation for any other reasonably foreseeable loss or damage. You are also entitled to have the goods repaired or replaced if the goods fail to be of acceptable quality and the failure does not amount to a major failure.

Toro Australia Pty Ltd, 53 Howards Road, Beverley SA 50091300 130 898, info.au@toro.com

FCC Part 15 Rules

This equipment has been tested and found to comply with the limits for a Class B digital device, pursuant to Part 15 of the FCC Rules. These limits are designed to provide reasonable protection against harmful interference in a residential installation. This equipment generates, uses and can radiate radio frequency energy and, if not installed and used in accordance with the instructions, may cause harmful interference to radio communications. However, there is no guarantee that interference will not occur in a particular installation. If this equipment generates interference to radio or television reception, which can be determined by turning the equipment on and off, the user is encouraged to try to correct the interference by one or more of the following measures:

1. Reorient or relocate the receiving antenna.
2. Increase the separation between the equipment and receiver.
3. Connect the equipment into an outlet on a circuit different from that to which the receiver is connected.
4. Consult the dealer or an experienced radio/TV technician for help.

The user may find the following booklet prepared by the Federal Communications Commission helpful: "How To Identify and Resolve Radio-TV Interference Problems". This booklet is available from the U.S. Government Printing Office, Washington, DC 20402. Stock No. 004-000-00345-4.

