



Installation and Service Instructions

640 Series Rotary Sprinkler

Installation Procedure

To assure maximum performance from your 640 Series Rotary Sprinklers, read these instructions completely prior to installing or servicing the sprinkler.

Construct Swing Joints

1. Construct triple swing joints for each sprinkler as shown in Figure 1. Use PVC or ABS pipe nipple for sprinkler connection.

Note: On sites where the possibility of heavy equipment rolling over a sprinkler exists, the swing joint will flex preventing damage to the lateral or main lines. On a new installation in raw ground where the sprinklers are to be initially installed above the finished grade and lowered when new turf is established, the swing joint allows sprinkler repositioning without changing risers. This is a common and practical procedure which eliminates the problem of dirt being accidentally introduced into the lateral lines when a riser is changed.

2. Flush lines thoroughly prior to installing sprinkler.
3. Apply Teflon™ tape on riser threads. Install sprinkler to riser and tighten.

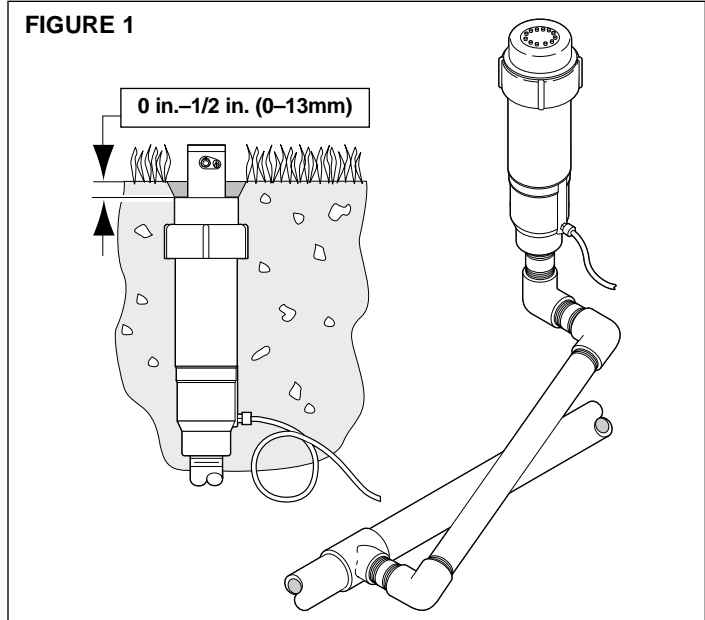

CAUTION

Use only Teflon tape on riser threads. Use of pipe dope or other types of sealing compounds can cause deterioration of plastic threads and components.

4. Install sprinkler on riser. Align part-circle heads by rotating sprinkler body on riser until radius adjustment slot on top of the nozzle rubber cover is positioned to the left side of the intended coverage area.
5. **Valve-In-head models only:** Remove tube retainer and cap from sprinkler fitting. Provide a service loop in control tube at sprinkler to prevent binding. Slide tube retainer over end of control tube. Push control tube onto sprinkler fitting and secure with tube retainer.
6. Install sprinklers flush with grade to 1/2 in. (0–13mm) below grade.
7. Backfill and compact soil around sprinkler avoiding contact with nozzle assembly.

Servicing the Sprinkler

Valve Replacement



WARNING

POSITIVELY SHUT OFF WATER SUPPLY AT SOURCE PRIOR TO DISASSEMBLING SPRINKLER. BLEED ALL PRESSURE FROM SPRINKLER SYSTEM INCLUDING CONTROL TUBES. FAILURE TO DEPRESSURIZE SYSTEM PRIOR TO VALVE SNAP RING REMOVAL MAY CAUSE VALVE MECHANISM TO FORCIBLY EJECT FROM SPRINKLER BODY RESULTING IN POSSIBLE SERIOUS INJURY.

1. Remove cap set screw with 1/8 in. hex wrench and unscrew cap.
2. Remove nozzle container seal, nozzle retainer and nozzle/drive assembly from body.
3. Depress valve mechanism using a long screwdriver or similar tool (see CAUTION below).

CAUTION

Do not continue valve removal procedure if the valve cannot be pressed down with minimum force. Confirm that water pressure is off and the control tube is bled before continuing.

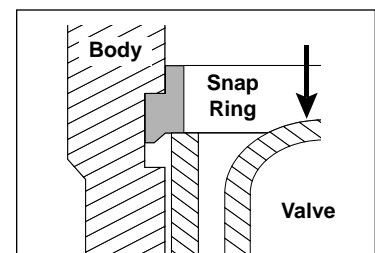

4. With the valve depressed, grasp snap ring "ears" with TORO snap ring pliers (Model No. 995-07), release snap ring from groove and remove from body.
5. Remove valve mechanism with TORO Valve Removal Tool (Model No. 995-08) or carefully grasp one valve rib with snap ring pliers, pulling valve up and out of body.
6. Reassemble valve mechanism in reverse order.

Note: Due to limited work space in 640 sprinklers, use of Toro Valve Insertion Tool (Model No. 995-35) is recommended to simplify valve and snap ring installation.
7. See **Reinstalling Nozzle/Drive Assembly**.

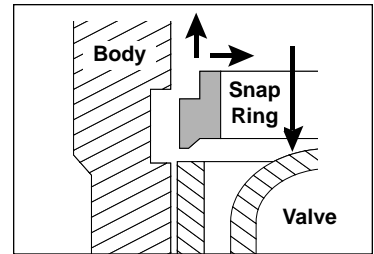

Changing Nozzle and Stator

Note: Nozzle changes may be accomplished by changing the entire nozzle assembly or by removing the nozzle container end changing only the upper nozzle. In either case, the appropriate matching stator must be installed (i.e., No. 42 Nozzle and No. 42 Stator, etc.) to ensure proper sprinkler operation.

Changing Complete Nozzle Assembly

1. Remove cap set screw with 1/3 in. hex wrench and unscrew cap.
2. Remove nozzle container seal, nozzle retainer and nozzle/drive assembly from body.
3. Remove 1/16 in. allen set screw in side of nozzle canister.
4. Unscrew nozzle assembly from drive assembly.
5. Assure nozzle seal is located at bottom of nozzle base threads.
6. Install new nozzle assembly — **HAND-TIGHTEN ONLY, DO NOT OVER-TORQUE.**
7. Turn set screw clockwise until contact with riser threads is made (see CAUTION below).

CAUTION

Do not over-torque set screw. Over-tightening will cause thread damage and possible water leak between lower nozzle base and drive assembly.

8. Remove boss on nozzle rubber cover to identify drive assembly arc.

FIGURE 2

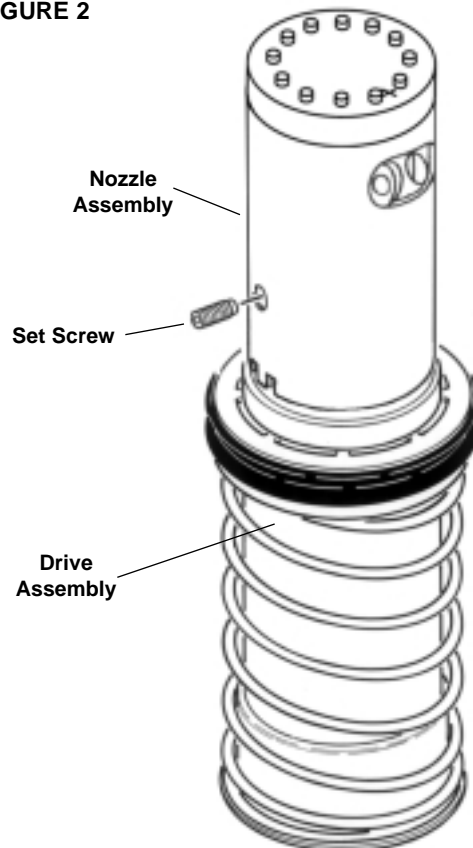

Changing Upper Nozzle

Note: Some of the nozzle assembly components shown in the following procedure are no longer available from Toro as service parts. This procedure should only be used if the upper nozzle assembly is already on hand.

1. Remove cap set screw with 1/8 in. hex wrench and unscrew cap.
2. Remove nozzle container seal, nozzle retainer and nozzle/drive assembly from body.
3. Straighten locking tabs on nozzle container with nozzle container removal tool, Model No. 995-42 or other appropriate tool (see Figure 3).
4. Remove nozzle container, nozzle screws and upper nozzle assembly (see Figure 4).
5. Position new upper nozzle assembly and secure with nozzle screws. DO NOT OVER-TIGHTEN SCREWS. (See Figure 4 and Note below.)

Note: Over-tightening nozzle screws will expand plastic nozzle base causing difficult nozzle container replacement.

6. Align nozzle opening in container with nozzle orifices and press container downward until fully seated on nozzle assembly.
7. Bend locking tabs into notches approximately 90° to secure nozzle container.

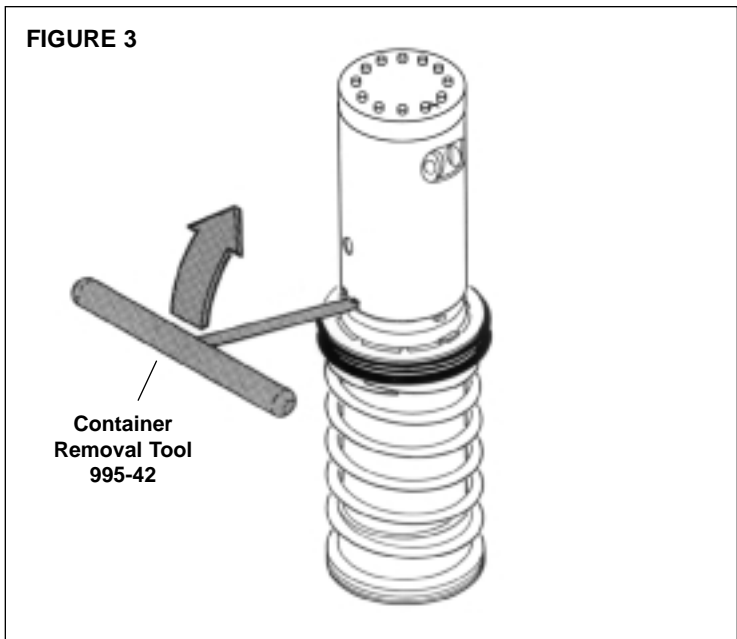

Changing Stator

1. Place nozzle/drive assembly on a flat work surface, nozzle down, and compress return spring to expose stator assembly (see Figure 5).
2. Separate stator from drive assembly (held together by press fit) and CAREFULLY relieve return spring tension.
3. Press in new stator assembly to fully seated position.

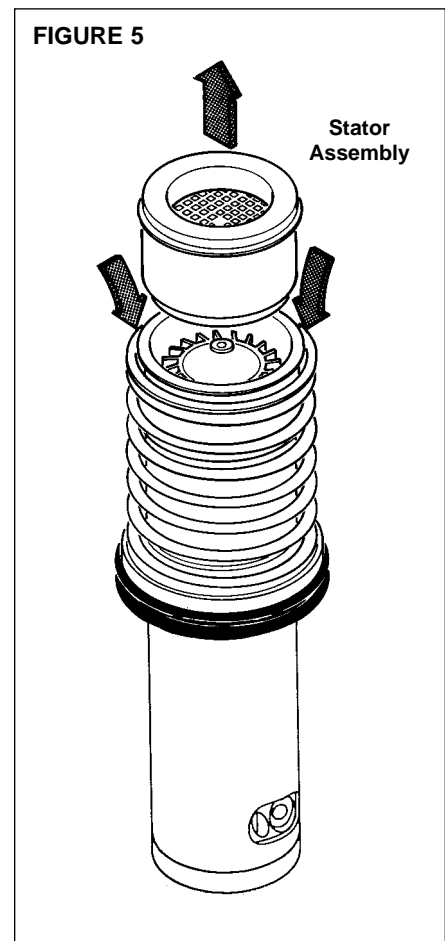
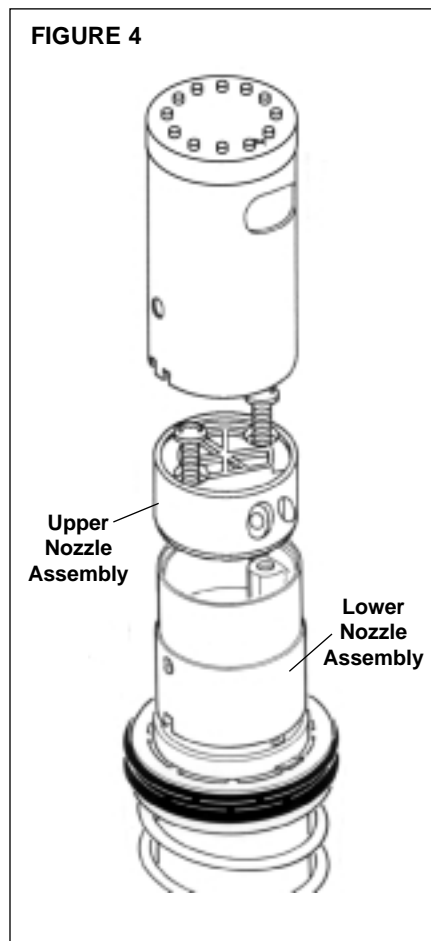

Reinstalling Nozzle/Drive Assembly

1. **Part Circle Only:** Holding drive assembly stationary, slowly rotate nozzle assembly counterclockwise to left side of arc pattern (see Figure 6).
2. Check drive assembly key tab for approximately 30° upward bend, adjust if necessary (see Figure 7).
3. Insert nozzle/drive assembly into body until seal is approximately one (1) inch below top of body.
Part Circle Only: Align main nozzle orifice with left edge of watering arc before inserting (see Figure 8).
4. Place nozzle retainer over nozzle assembly aligning keyway and drive assembly key (see Figure 9).

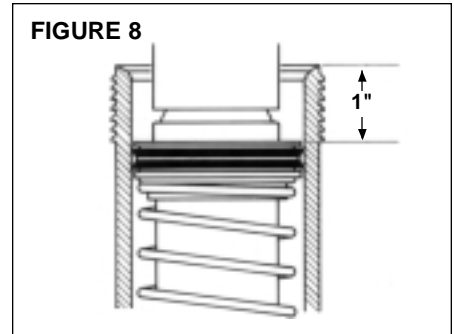
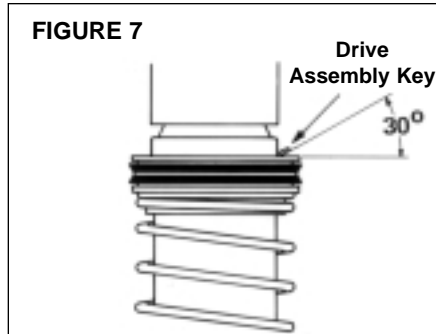
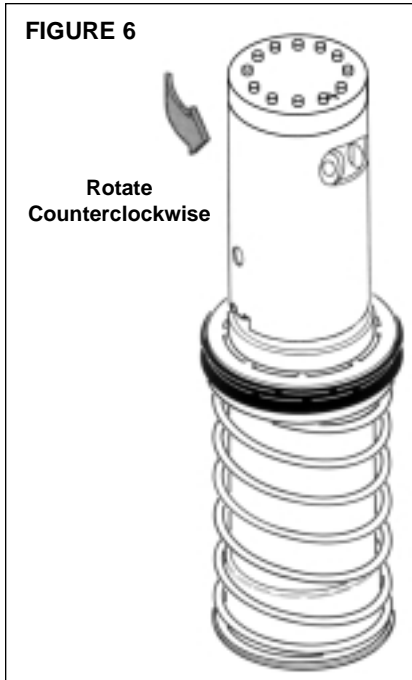

5. Rotate nozzle retainer, interlocked with nozzle/drive assembly, to align the nearest of six (6) alignment slots with tabs on body (see Figure 10).
6. Press retainer into body to interlock alignment slot and body tab.
7. Install riser seal over nozzle assembly placing peg into retainer keyway (see Figure 11).
8. Install cap and secure with set screw.
9. Check watering arc. If minor adjustments are required (1/6 of a turn or less); rotate sprinkler body on riser. **Do not make adjustments by turning nozzle assembly** (see CAUTION below).

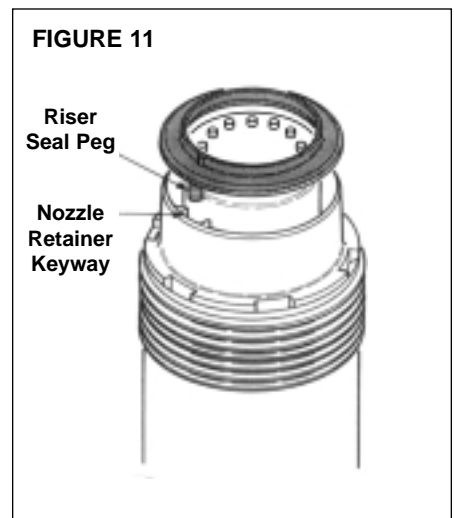
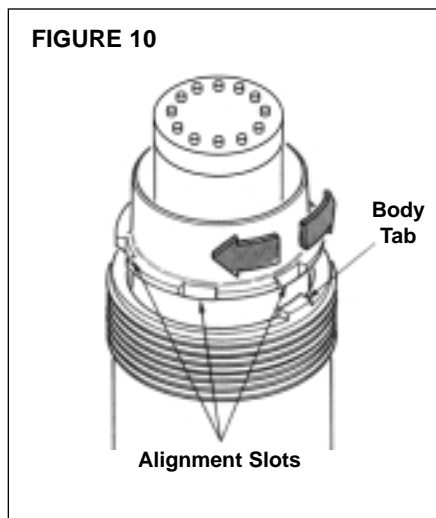
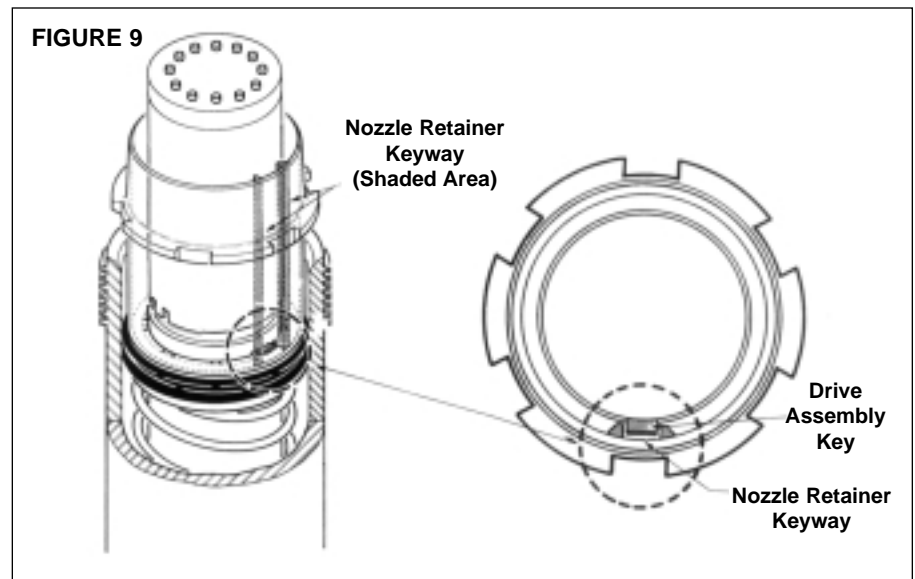

CAUTION

Rotating nozzle assembly to make watering arc adjustments may cause severe internal damage to drive assembly.

Note: Refer to Illustrated Parts Breakout Book Form No. 368-0044 for current parts listing.

